



RIBBONMICS & PREAMPS | since 1964

www.ribbonmics.com | tel: +1-626-798-9128 | fax: +1-626-798-2378



AEA N8

PHANTOM-POWERED RIBBON MICROPHONE

{ OWNER'S MANUAL }

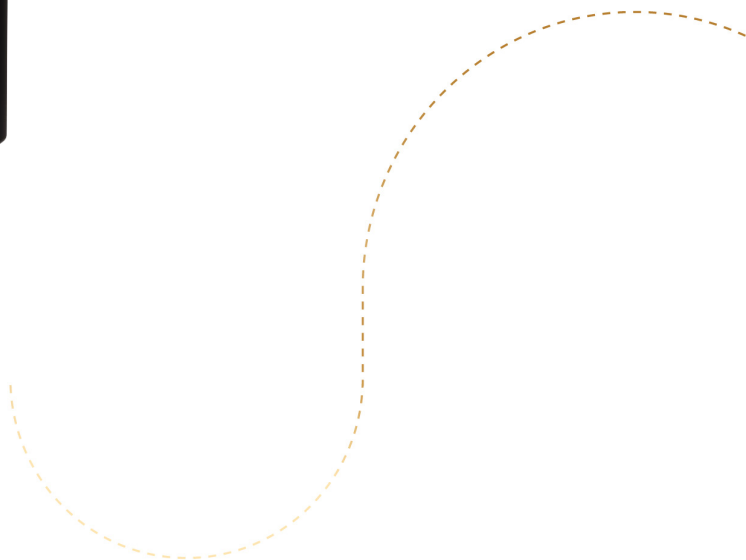

{ WELCOME }

Congratulations on your purchase of the AEA N8 phantom-powered ribbon microphone and welcome to the AEA family. The AEA N8 was designed to be the most open and natural sounding ribbon microphone we could make. Conceived to render acoustic spaces as faithfully as possible, the new N8 microphone excels in capturing drum overheads, strings, classical ensembles, orchestras, and rooms. As such, it is the ideal complement to the N22 microphone. But even when used up close, such as on guitar and bass amps, the N8 delivers exceptional clarity and warmth, while also taking EQ extremely well. Additionally, the N8's unobtrusive size and black finish is ideal for orchestral and TV work, where microphones need to be easy to position and more or less invisible.

Your N8 microphone is 100% handcrafted in Pasadena, CA. AEA is a family owned company with a small crew of skilled technicians, many being musicians themselves. Proudly independent, we still manufacture all our ribbon microphones and preamps by hand from mostly locally sourced parts.

We hope that the N8 will help you capture many magical performances that touch the heart. Read this manual thoroughly to make sure that you get the best sound and longevity from your new microphone. Please become part of the AEA community by sharing your experiences with the N8 via e-mail, phone or our social media channels.

Wes Dooley
President of AEA

{ TABLE OF CONTENTS }

WELCOME	2
INTRODUCTION	4
GENERAL GUIDELINES	4
APPLICATION ADVICE	5
<i>Controlling Leakage</i>	5
<i>Proximity Effect</i>	6
<i>Drums and Percussion</i>	7
<i>Strings, Brass, and Reeds</i>	8
<i>Piano</i>	8
<i>Electric Guitar and Bass</i>	9
PRECAUTIONS	9
<i>Phantom-power</i>	10
<i>Wind Gusts</i>	10
<i>Tramp Iron</i>	10
<i>Microphone Positioning</i>	11
<i>Magnetic Stray Fields</i>	11
SPECIFICATIONS	12
WARRANTY	14
SUPPORT	14

{ INTRODUCTION }

The N8 is a side-address, phantom-powered ribbon microphone with a bidirectional (or figure-of-8) pickup pattern. It was designed for distant miking applications like drum overheads, rooms, strings, and classical ensembles, but it is also well suited for up-close use. With phantom-powered JFET electronics and a custom German transformer the N8 achieves optimal performance with a wide range of preamps ranging from vintage high-end models to USB audio interfaces in home studio setups. The N8 is the second member of AEA's NUVO series. Rooted in the RCA tradition just like other AEA ribbons, all NUVO microphones are designed to offer a fresh approach to the ribbon transducer; it represents Wes Dooley's take on the evolution of the ribbon microphone.

{ GENERAL GUIDELINES }

The two sides of the N8 (front and back) are voiced exactly the same. Keep in mind, however, that the backside has opposite polarity compared to the front. Positive polarity is achieved by positioning the side with the "NUVO" logo towards the sound source.

The supplied microphone clip will provide adequate vibration isolation in most situations.

To maintain the best performance from your new AEA N8 microphone, take note of these four basic rules:

- 1) Keep the microphone covered when it is not in use.
- 2) Always use a sturdy microphone stand.
- 3) Never expose the microphone to strong air turbulence.
- 4) Be nice to the microphone, and it will be nice to you.

1) Keeping the microphone covered when it is not in use will reduce the possibility of damage that might result from a sudden gust of air coming from air-conditioning or an open door or window. Place the supplied protective bag (or a standard plastic bag) over the microphone when it is not in use. For longer-term storage, replace the microphone in its protective case.

2) While the N8 was designed to work well with all standard microphone stands, a high-quality boom stand will still make your life a little bit

easier. If you are using a boom, make sure that it is properly balanced and that the tripod legs are positioned appropriately to prevent tipping.

3) Ribbon microphones can withstand very high SPL (sound pressure levels) without difficulty, but can be damaged easily by a sudden, strong gust of air or high levels of low frequency sound waves (like from a kick drum or bass cabinet). This can stretch the ribbon, causing the microphone to lose sensitivity and distort its frequency response. To avoid possible damage, follow this simple procedure when positioning the microphone. Put the back of your hand where the mic will be; if you can feel the motion of air on your hand, place a pop-filter between the microphone and the source of the air turbulence. When recording kick drums or bass guitar cabinets, angle the microphone to make sure that no wind blasts hit the ribbon head-on.

4) Your N8 is a valuable and important investment. Like any piece of recording equipment or musical instrument, it requires common sense and good basic care to keep it working properly. Given simple, basic care as described above, your new microphone will perform admirably for decades.

{ APPLICATION ADVICE }

Controlling Leakage

A significant and ever-present challenge in contemporary studio recording is minimizing “bleed” (also called “leakage” or “crosstalk”) from nearby instruments into the various microphones. The deep nulls of bidirectional ribbon microphones provide good rejection of unwanted sounds, which also can be beneficial in sound reinforcement situations where feedback is always a threat. While gobos can be effective in isolating performers from each other, they introduce their own set of problems - not the least of which are reflections in close proximity to the performers and/or microphones that result in comb-filter distortions. Because gobos usually are bulky and occupy valuable floor space, they also inhibit the ability of the musicians to hear and see each other easily. Such a setup requires complex and often cumbersome headphone monitor mixes for the musicians.

Because the N8 has a bidirectional pattern, it has nulls at 90° / 270° from the principal (front) axis. Projected in three dimensions, these nulls produce a “plane of rejection” to the sides of the microphone that can

be used effectively to reduce leakage. Simply arrange the musicians so that nearby instruments are placed in the “null” of their neighbor’s microphone, and vice versa. Although this does not entirely eliminate the need for gobos, it can significantly reduce their number.

Keep in mind that a certain degree of bleed does not necessarily have to be bad. For some styles and genres it can in fact be beneficial to embrace a little bit of bleed in order to create cohesive and natural sounding recordings. The important thing to listen for is whether or not other instruments that bleed into a specific instrument microphone still sound natural. You will generally find that well-designed ribbon microphones like the N8 capture a natural off-axis sound, which means that bleed from other instruments can contribute to the overall sound in a pleasing way.

Proximity Effect

Proximity effect is a characteristic of all directional microphones; it is a rising low-frequency response at closer working distances. While this can be used to good effect, particularly with male voices to give them an enhanced richness and depth, the potential tradeoff is reduced articulation or clarity that can result from the masking effect on the treble due to “excessive” bass response.

Experienced vocalists instinctively locate the proper working distances

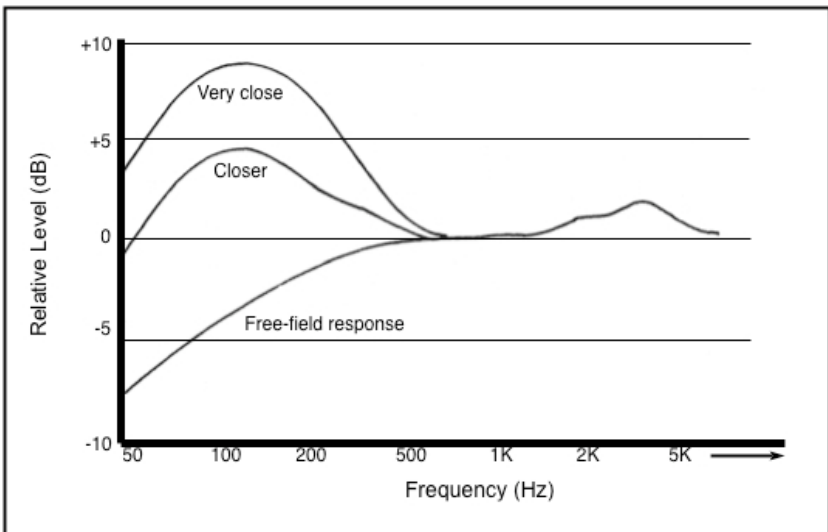

for the microphones they are using. From as early as the 1930s, Frank Sinatra always kept one hand on the microphone stand while singing. Some joked that he simply was steadying himself, but more knowledgeable people noticed that he would bring the mic closer for more intimate moments, and then move it farther away when he belted out a line. This technique became known as “working the mic.”

Your N8 was designed to exhibit a balanced sound at relatively far distances from the sound source; it works equally well placed close to the source.

Application Examples

Obviously your ears are the best judge of microphone choice and placement. However, AEA has garnered a great deal of experience testing the N8 in a variety of recording settings and talking to experienced musicians and engineers. As a result we suggest the following guidelines to help you to achieve optimum results when using the N8. In addition, make sure to watch the videos on our website (www.ribbonmics.com) and on our YouTube channel (www.youtube.com/AEARibbonmics) for more tips.

Drum Overheads, Rooms, and Percussion

When recording drums, there are many techniques to capturing the sound of the kit. A good starting point is to use the N8s above the kit as a spaced pair. Try positioning them a couple of feet above the drummer’s head with a few feet of space in between the two mics. Make sure to listen to the combined signal summed to mono to catch potential comb filtering that could be caused by out-of-phase signals. A quick technique that can help avoid phase problems is to keep an equal distance between the two overhead mics and the snare or kick drum.

Another popular technique to record drum overheads is to setup the mics in a Blumlein configuration (coincident pair at 90 degree angle) above the head of the drummer with each mic pointing in a different direction. This will give you a very wide image of the drums that sounds like you are in sitting center stage.

Both of these techniques also work well for recording the sound of the room. The closer that the N8s are positioned to the drummer, the more direct sound and less reverb will be captured by the mics.

Strings, Brass, and Reed Instruments

Because the N8 has equal treble and bass response from a far distance, it can be placed almost anywhere without sounding thin. Feel free to position the mic both closer and further away than you normally would with a condenser.

When recording acoustic instruments, a good starting point is to walk around the room while the musician is playing. When you find a spot where you like the sound, try positioning the N8 there and move to taste.

For solo instruments, try placing the N8 a few feet away. This will give a very up-close and personal sound. Set the microphone above or in front of the instrument. The height of the mic in relation to the height of the room can have a large impact on the sound.

When positioning the N8, try aiming the backside towards a complex wall intersection. This can capture the reverberation of the room in an interesting way.

For bass string instruments that are bowed and plucked, placing the N8 about a foot away will give you a very nice and defined low end. The proximity effect of the N8 can be used to your advantage.

For instrument sections, a good starting point is to place the N8 a few meters away where the musicians have a nice balanced sound. Blumlein configuration positioned at a distance of 4 - 6 meters from a section can capture the sound with a lot of depth.

The N8s can also be used with great results to capture an entire orchestra. Try positioning the mic in the same way that you would for sections, but from a much further distance. Two N8s on a stereo bar facing outwards at 90 degrees can give you a realistic spatial image that will sound like you are standing in front of the orchestra.

Piano

The N8 delivers a great sound as a close-up and distant mic on both upright and grand pianos. On an grand piano we have found two positions to be particularly useful.

1. Spaced pair of N8s looking at the hammers in the front. You will need to remove the front cover of the grand piano. This position will yield a very natural, hi-fi sound. It is common to pull the mics further out of the

piano then you would with a pair of condensers. You can change the amount of natural room reverb by changing the distance between the mics and piano.

2. Blumlein pair (coincident pair at 90 degree angle) of N8s positioned on the side of the piano facing the player: one microphone pointing towards the treble side of the piano, and the other microphone facing towards the bass side that can result in a larger than life recording.

Electric Guitar and Bass

The N8 can handle very high sound pressure levels allowing you to place it close to amplifiers. Watch out for wind blasts, percussive players, and very loud bass cabinets that push air. The N8 has the least amount of protection in it for a more open sound which means you should be extra careful to avoid sudden blasts of wind.

Identify where the center of the speaker cone is located and place the N8 a few inches away from the speaker pointing right at its center for a very direct, "in-your-face" sound. This is the spot where you will get the most high-frequency content. If it sounds too harsh, try moving the microphone to the side parallel to the speaker. You can also try positioning the N8 at an angle. You will find that small differences in positioning can make huge differences in the sound, so experiment until you find the spot you like.

The N8 has much more proximity effect than the nearfield N22. This can be an advantage when trying to thicken up a thin or tinny sounding guitar.

For a more natural sound that captures the sound of the amp in your room, try backing the microphone up a couple of feet.

{ PRECAUTIONS }

Most ribbon microphones need little, if any, maintenance. Given proper care they last for decades. Bing Crosby's personal RCA-44BX (now in the collection of the Pacific Pioneer Broadcasters in Hollywood) sounds as good today as it did when he recorded his radio broadcasts in the 1940s.

A few simple precautions will help you to keep your AEA N8 working well for life:

Phantom Power

Although the N8 needs a standard 48V phantom-power source to operate, you should still make sure that phantom power is turned off before plugging and unplugging the microphones. The loud pops that occur when the microphone is plugged in with phantom-power engaged can damage speakers, headphones, and ears. Since passive ribbon microphones or other transformer-coupled microphones are particularly sensitive to phantom-power, it is recommended to disengage phantom-power before plugging and unplugging a habit.

Wind Gusts

A second and equally important rule is never to blow directly into a ribbon microphone to test it. Strong air turbulence can stretch the ribbon diaphragm and while it may not break, it will nonetheless significantly degrade the microphone's performance. Using the mic outdoors requires special care so that the wind does not damage the ribbon. Indoors, however, it is also important to avoid serious air turbulence as could be caused by open windows, air-conditioning systems or a slammed door. Use the supplied cloth bag to cover the microphone whenever it is not in use. High SPL sound sources do not usually pose a problem because most ribbon microphones can handle 130 dB SPL or more without difficulty. It is only those "explosive" sources that produce a strong blast of air, such as the bass port on an electric guitar or bass amp, a guitar being plugged (or unplugged) while the amp level is turned fully up, an on-axis kick-drum (particularly with a port on the front head), that require special protection. If you are unsure about how much wind is hitting the microphone, place the back of your hand where the microphone is going to be. If you are still concerned about wind blasts, angle the microphone.

Tramp Iron

Remember also that most ribbon microphones contain a magnet that produces a fairly strong magnetic field. This field can attract any ferric objects near the microphone that, if they are small enough, can penetrate the outer screening and work their way inside the microphone. Minute iron particles, sometimes known as "tramp iron," exist everywhere within our environment. When in close proximity to a ribbon microphone, these can be pulled inside. Over time, tramp iron can build up sufficiently in the magnetic gap to rub against the ribbon, causing distortion or electrical shorts. Under no circumstances should you disassemble and take the grill off of the microphone as this could allow tramp iron to enter

the narrow gap between the ribbon and the pole pieces.

Microphone Positioning

The shock-mounted clip that is supplied with the N8 microphone was designed to keep structure-borne noise transmitted through the microphone stand away from the low-tuned ribbon transducer. For the shock mount to function as intended and to avoid vibration entering the microphone through its attached cable, it is important to tie the microphone cable to the microphone stand in a loop with a cable tie, shoelace or string.

Magnetic Stray Fields

Ribbon microphones are fundamentally prone to picking up strong external magnetic fields caused by light dimmers or nearby power transformers. Guitar players will know this phenomenon from single-coil pickups. Even though much attention was paid to suppressing these magnetic fields in the design of the N8, it is still possible that you might encounter this problem. If you should pick up a hum, try rotating or moving the microphone to find a spot where the hum disappears and try eliminating potential sources of stray magnetic fields.

Avoid placing the microphone in close proximity to hard drives, credit cards, analog tape, or any other magnetically-sensitive items to prevent any data loss.

{ SPECIFICATIONS }

Operating Principle:	Pressure gradient transducer
Directional Pattern:	Bidirectional
Frequency Range:	< 20 Hz to 20 kHz
Maximum SPL:	141 dB SPL (1% third harmonic > 1 kHz)
Sensitivity:	8.3 mV/Pa (at 1 kHz, no load)
Rated Impedance:	92 Ω broadband
Rated Load Impedance:	1.0 k Ω or greater
Phantom Power:	P48 phantom power, 7 mA
Polarity:	Pin 2 high for positive pressure at the front of the microphone.
Off Axis Response	Bidirectional Level changes with angle of incidence, but frequency response is consistent. Up to 90 dB rejection at 90 / 270 degrees
Transducer Element	
Material:	Pure aluminum corrugated ribbon
Thickness:	1.8 μ m
Width:	0.185 in (4.7 mm)
Length:	2.35 in (59.7 mm)
Microphone Dimensions:	
Height:	8.83 in (32.4 cm)
Width:	1.62 in (11.7 cm)
Depth:	1.62 in (9.5 cm)
Weight:	12 oz (335 g)
Shipping Weight:	1 lb 13 oz (810 g)
Connector:	XLR-3M

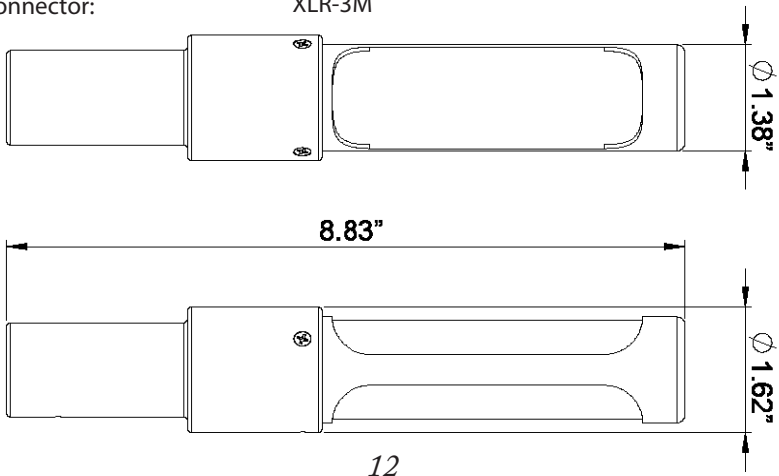

AEA N8 Frequency Response

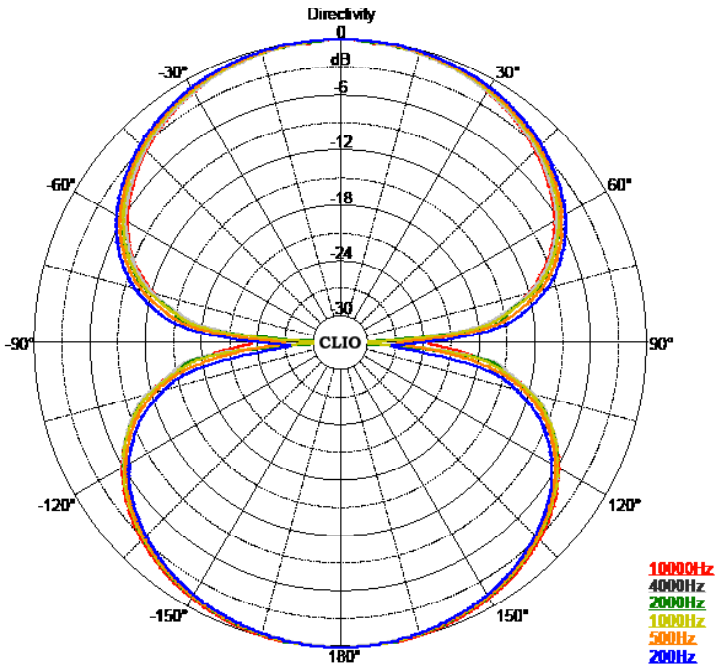
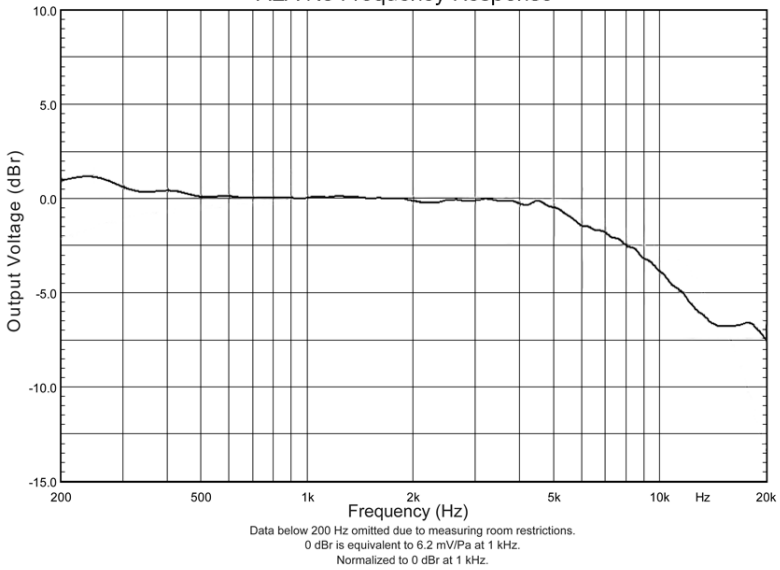

Accessories Included:

Storage/shipping case, microphone stand clip,
custom protective mic sleeve, user manual

{ WARRANTY }

Your N8 microphone comes with a one-year limited warranty on parts and labor, shipping not included. Please see the supplied warranty card for details.

Registering your microphone with AEA will extend the warranty to a full three years. Simply fill out the supplied registration form and send it to:

Audio Engineering Associates
1029 N. Allen Ave
Pasadena, CA 91104

You may also register your AEA equipment online at <http://www.ribbonmics.com/aea/form.php>

{ SUPPORT }

If you should encounter any problems with your microphone or if you have questions regarding using the N8 in specific application, please contact our customer support team at support@ribbonmics.com

To talk to a live human being, call +1 (626) 798-9128, between 8:00 - 6:00 pm PST Monday through Friday.