



**ATTENTION!**

If any components of this unit are broken, do not operate properly, or for product returns, please contact Weston Products LLC  
Phone: 1-800-814-4895 (Outside the U.S. 440-638-3131)  
20365 Progress Drive, Strongsville, Ohio 44149  
WestonProducts.com

*All Trademarks and Registered Trademarks are property of the respective companies.*

**SAVE THESE INSTRUCTIONS!**

*Refer to them often and use them to instruct others.*

**Roma**<sup>TM</sup>  
by **WESTON**<sup>®</sup>

**Food Strainer &  
Sauce Maker**

**MODEL NO. 07-0801**



PATENTED

*Due to constant factory improvements, the product pictured might differ slightly from the product received.*

RREV031511

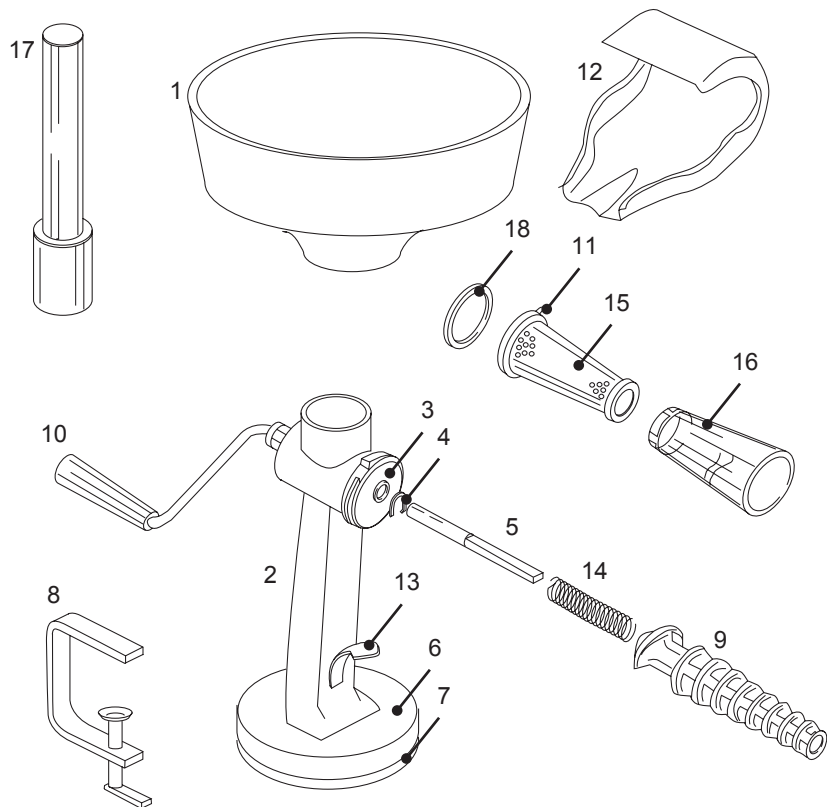

## WESTON WARRANTY INFORMATION

### SAVE THIS WARRANTY INFORMATION FOR YOUR RECORDS!

Weston Products LLC warrants to the ORIGINAL RETAIL PURCHASER of this product that if operated in accordance with the printed instruction accompanying it, then for a period of 1 year from the date of purchase, the product shall be free from defects in material and workmanship.

The Warranty Card, along with a copy of the original receipt, must be received by Weston Products LLC within 30 days from purchase date for the warranty to apply. Failure to send the completely filled out Warranty Card, along with a copy of the original receipt, will void the warranty.

The product must be delivered to or shipped freight prepaid to Weston Products LLC for warranty services, in either its original packaging or similar packaging affording an equal degree of protection. Damage due to shipping is not the responsibility of the company. Weston Products LLC charges a \$35.00 per hour bench charge. **NOTE:** No repairs will be started without the authorization of the customer. The return shipping cost to the customer will be added to the repair invoice.

Weston Products LLC will repair (or at its discretion, replace) the product free of charge, if in the judgment of the company, it has been proven to be defective as to seller's labor and material, within the warranty period.

New or rebuilt replacements for factory defective parts will be supplied for one (1) year from the date of purchase. Replacement parts are warranted for the remainder of the original warranty period.

For non-warranty repairs, contact Weston Products LLC's Customer Service at 1-800-814-4895 M-F 8am-5pm EST (outside of the United States 440-638-3131) to obtain a Return Merchandise Authorization Number (RMA Number). Weston Products LLC will refuse all returns that do not contain this number. **DO NOT RETURN THE UNIT WITHOUT PROPER AUTHORIZATION FROM WESTON PRODUCTS LLC.**

**LIMITATIONS:** The warranty is void if the product is used for any purpose other than that for which it is designed. The product must not have been previously altered, repaired, or serviced by anyone else other than Weston Products LLC. If applicable, the serial number must not have been altered or removed. The product must not have been subjected to accident in transit or while in the customer's possession, misused, abused, or operated contrary to the instructions contained in the instruction manual. This includes failure caused by neglect of reasonable and necessary maintenance, improper line voltage and acts of nature. This warranty is not transferable and applies only to U.S. and Canadian sales.

Except to the extent prohibited by applicable law, no other warranties whether expressed or implied, including warranty merchantability and fitness for a particular purpose, shall apply to this product. Under no circumstances shall Weston Products LLC be liable for consequential damages sustained in connection with said product and Weston Products LLC neither assumes nor authorizes any representative or other person to assume for it any obligation or liability other than such as is expressly set forth herein. Any applicable implied warranties are also limited to the one (1) year period of the limited warranty.

This warranty covers only the product and its specific parts, not the food or other products processed in it.

CUT ALONG THE DOTTED LINE AND SEND THE WARRANTY CARD ALONG WITH A COPY OF YOUR ORIGINAL PURCHASE RECEIPT TO:

**Weston Products LLC**  
**20365 Progress Drive, Strongsville, OH 44149**

## WESTON WARRANTY CARD

SEND THIS CARD ALONG WITH A COPY OF YOUR ORIGINAL PURCHASE RECEIPT TO:  
 WESTON WARRANTY, WESTON PRODUCTS LLC, 20365 PROGRESS DRIVE, STRONGSVILLE, OH 44149

Customer Name: \_\_\_\_\_

Address: \_\_\_\_\_

City/State/Zip: \_\_\_\_\_

Telephone Number: (\_\_\_\_\_) \_\_\_\_\_

E-Mail Address: \_\_\_\_\_

Original Date of Purchase: \_\_\_\_/\_\_\_\_/\_\_\_\_

Product Model #: \_\_\_\_\_

Serial # (if applicable): \_\_\_\_\_



## GRAPE JUICE

fresh grapes

sugar to taste

water

- Clean and remove grapes from stems
- Run grapes through the **Food Strainer & Sauce Maker** using the **Grape Spiral** (Sold Separately)
- Add as much water as juice
- Add sugar to taste
- Heat to almost boiling
- Put in jars and seal
- Serve chilled

## GRAPE SYRUP

1-1/4 cups grapes

1-1/2 cups sugar or honey

1/4 cup corn syrup

1 Tbsp lemon juice

- Run grapes through the **Food Strainer & Sauce Maker** using the optional **Grape Spiral** (Sold Separately)
- Combine all ingredients in a heavy pan
- Bring to a rolling boil for 1 minute (Start timing after mixture comes to a boil and the foam cannot be stirred down)
- Remove from heat, skim off foam
- Pour into 1/2 pint (0.2 liter) glasses
- Cool, cover, and store in refrigerator
- Serve with pancakes, biscuits, over ice cream, or over vanilla pudding

## BABY FOOD - STEAMED VEGETABLES

1 cup fresh vegetables, diced (Use Carrots, Squash, Beets, Beans, or Peas)

1/4 cup water

- Wash vegetables and steam over low heat until tender
- Keep saucepan tightly covered adding additional water if necessary, do not overcook
- Cool and run through the **Food Strainer & Sauce Maker** using the **Multi-Purpose Screen**
- If a finer consistency is desired the *optional* Berry Screen can be used
- If any liquid is left in the pan it may be used to thin the vegetable puree
- Add the liquid slowly and stir until the right consistency is reached

## ROLLED OATS AND BANANAS

1/4 cup rolled oats

1/2 cup water

1/3 ripe banana

1/4 cup milk

- Combine rolled oats and 1/2 cup of water
- Bring to a boil
- Simmer for 5 minutes, stirring occasionally
- Remove from heat
- Cover and let stand for 5 minutes
- Run banana through the **Food Strainer & Sauce Maker** using the **Multi-Purpose Screen**
- Add milk and mix thoroughly
- Stir the banana-milk mixture into the rolled oat mixture

## COMPONENT LIST

DIAGRAM NUMBER	PART DESCRIPTION	PART NUMBER
1	Large Hopper	07-0834
2	Body	07-0832
3	Drive Shaft O-Ring Seal	07-0820
4	Drive Shaft Clip	07-0821
5	Drive Shaft	07-0835
6	Suction Cup Body	07-0840
7	Suction Cup	07-0841
8	C-Clamp	07-0842
9	Spiral	07-0823
10	Handle	07-0829
11	Screen Thumbscrew	07-0843
12	Squirt Guard/Chute	07-0838
13	Suction Cup Lever	07-0830
14	Drive Shaft Spring	07-0822
15	Multi-Purpose Screen	07-0836
16	Waste Funnel	07-0837
17	Stomper	07-0844
18	Screen Gasket	07-0824

If any components of this unit are broken or the unit does not operate properly, call Weston Products LLC Toll Free at

**1-800-814-4895**

Monday thru Friday 8:00am-5:00pm EST. Outside the U.S. call 440-638-3131

**CAUTION!** It is important to follow the "Food Safety" guidelines outlined in this manual. For the most up to date instruction visit the USDA website.

# ASSEMBLY INSTRUCTIONS

1. Apply a few drops of vegetable oil to the rubber **Drive Shaft O-Ring**.

2. Insert the **Screen Gasket** into the large end of the **Screen** making sure the **Gasket** is under the **Thumbscrew**. *Figure A*

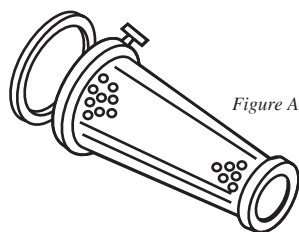

3. Slide the **Drive Shaft Spring** over the **Drive Shaft**.

4. Slide the red plastic **Spiral** onto the **Drive Shaft** over the **Spring**. Be sure to match the flats on the **Drive Shaft** to the metal insert in the inside of the **Spiral**. *Figure B*

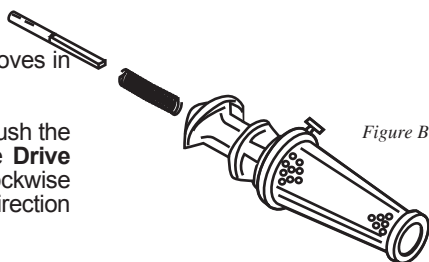

6. Align the notches of the **Body** with grooves in the **Drive Shaft Assembly**. *Figure C*

7. Holding the **Body** firmly in one hand, push the **Drive Shaft Assembly** firmly, then turn the **Drive Shaft Assembly** 1/8th of a turn counter-clockwise to lock it in place (NOTE: The "ON" - "OFF" direction arrows are on the base of the **Screen**).

8. Tighten the **Screen Thumbscrew** to lock the **Screen** in place (NOTE: Finger tighten only, do not over tighten). *Figure D* **NOTE: Operating the Food Strainer & Sauce Maker while empty is NOT recommended. The juice from the fruits and vegetables act as a lubricant for the mechanism and reduces wear on the components.**

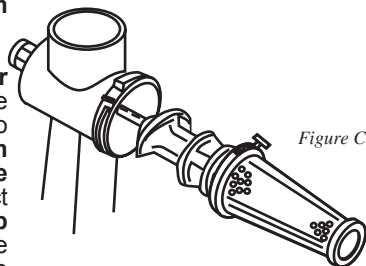

9. At this point you can attach the **Food Strainer & Sauce Maker** to your work space. If utilizing the **Suction Cup**, be sure the area you wish to adhere to is smooth, clean, and dry. Simply raise the **Suction Cup Lever** and hold the **Food Strainer & Sauce Maker** firmly in place with the **Suction Cup** in contact with the table surface, then press the **Suction Cup Lever** down. The **Suction Cup Lever** will require firm pressure to lock it into place. NOTE: If you have a rough or dirty surface, the **Suction Cup** may not adhere to the surface.

10. If utilizing the **C-Clamp**, simply position the **Food Strainer & Sauce Maker** near the edge of a table or counter. Slide the top end of the **C-Clamp** into the slot at the base of the **Food Strainer & Sauce Maker** and tighten the screw to the underside of the work surface.

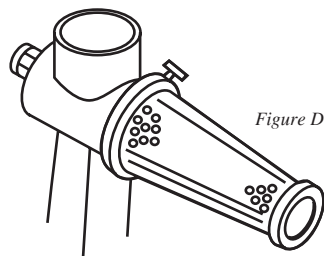

11. Slide the **Handle** into the **Food Strainer & Sauce Maker** making sure to align the slots in the **Drive Shaft** to the tabs on the **Handle**.

## VEGETABLE JUICE

8 qt fresh tomatoes  
3 small onions, finely chopped  
1 leek, only the white part, finely chopped  
1 Tbsp Worcestershire sauce  
1 cup carrots, finely chopped  
1 cup green pepper, finely chopped

8 stalks celery  
1/4 cup parsley  
1 lemon, juiced  
1/2 tsp allspice  
1 Tbsp salt  
black pepper, to taste  
hot sauce, optional

- Put tomato pieces along with finely chopped: celery (stalk and leaves), onion, leek, carrot and green pepper along with lemon juice into a large, non-aluminum, pot
- Cook over medium heat for 30 minutes until vegetables are soft
- Once the mixture has cooled, process through the **Food Strainer & Sauce Maker** using the **Multi-Purpose Screen**
- Season with: salt, allspice, Worcestershire sauce and pepper (add hot sauce now if desired)
- Serve chilled

## QUICK APPLESAUCE

3 Tbsp butter  
1 tsp cinnamon

6 Macintosh apples  
1/2 tsp nutmeg

1/4 cup sugar  
4 tbsp water

- Steam apples in a covered pot for approximately 15 minutes or until soft
- Allow apples to cool, then run through the **Food Strainer & Sauce Maker** using the **Multi-Purpose Screen**
- Mix the remainder of the ingredients with the apple puree and chill
- For variety, try different apples or mix them with different apples

## DELICIOUS AND HEALTHY APPLE CRISP

2-1/2 cups granola

2 Cups "Quick Applesauce"

3-1/2 Tbsp brown sugar

1-1/2 Tbsp butter

1-1/2 tsp cinnamon

whipped cream

- First make 2 cups of Quick Applesauce using the above recipe
- In a buttered baking dish alternate layers of granola with the Quick Applesauce
- End with a layer of granola
- Sprinkle with the cinnamon and brown sugar
- Spread the butter around in small pieces
- Bake in oven at 350°F (176°C) for 20 minutes
- Top off with whipped cream

## PUMPKIN BREAD

1 cup white sugar

1/2 cup brown sugar

1/3 cup butter or margarine

2 eggs

1 cup unbleached flour

2/3 cup whole wheat flour

1/4 tsp baking powder

1 tsp baking soda

1/4 tsp cloves

1/4 tsp allspice

1/3 cider

Fresh pumpkin

- Run the fresh pumpkin through the **Food Strainer & Sauce Maker** using the **Pumpkin Screen (Sold Separately)** to yield 1 cup of fresh pumpkin puree
- Preheat oven to 350°F (176°C)
- Cream the sugars and butter together until very light
- Add eggs one at a time, beating well
- Mix together flours, baking powder, baking soda, salt and spices
- Add alternately to creamed mixture with cider and pumpkin
- Beat well
- Turn into 2 greased loaf pans
- Bake for 1 hour until bread tests done with a toothpick

## RECIPES

U.S. VOLUME CONVERSIONS	
1 tsp	5 ml
1 Tbsp	15 ml
1/8 cup or 1 fl oz	30 ml
1/4 cup or 2 fl oz	60 ml
1/3 cup	80 ml
1/2 cup or 4 fl oz	120 ml
2/3 cup	160 ml
3/4 cup or 6 fl oz	180 ml
1 cup or 8 fl oz or 1/2 pint	240 ml
1 1/2 cup or 12 fl oz	350 ml
2 cups or 16 fl oz or 1 pint	475 ml
3 cups or 1 1/2 pints	700 ml
4 cups or 2 pints or 1 qt	950 ml
4 quarts or 1 gal	3.8 L

U.S. WEIGHT CONVERSIONS	
1 oz	28 g
1/4 lb or 4 oz	113 g
1/3 lb	150 g
1/2 lb or 8 oz	230 g
2/3 lb	300 g
3/4 lb or 12 oz	340 g
1 lb or 16 oz	450 g
2 lb	900 g

**PRIOR TO USING:** It is best to pre-soften some foods prior to use. If the food is firm like potatoes, apples or pears, remember to soften them by steaming or baking to tenderness before using them in the **Strainer**.

### LARGE BATCH ITALIAN TOMATO SAUCE

1/2 cup olive oil      3 medium onions, chopped      2 cloves garlic, minced  
 3 Tbsp brown sugar      1 Tbsp dried oregano      4 tsp salt  
 2 tsp dried basil      1 tsp black pepper      fresh tomatoes

- Run the fresh tomatoes through the **Food Strainer & Sauce Maker** using the **Multi-Purpose Screen** to yield 12 cups of fresh tomato puree
- Heat the olive oil in a large pan
- Sauté the onions and garlic until tender, do not overly brown
- Add the rest of the ingredients
- Bring mixture to a boil, reduce heat and simmer partially covered for 2 hours or until sauce has reduced to desired consistency
- Stir occasionally
- Serve or allow to cool then refrigerate or freeze
- Ingredients like sliced mushrooms, cooked/drained sausage, hamburger, etc. can be added to taste

### MARINARA SAUCE

1 cup carrots, finely minced      6 lbs ripe Italian-style tomato puree  
 1 cup onion, finely minced      1/2 cup celery, finely minced  
 1/2 cup olive oil      1 tsp sugar      ground white pepper, to taste

Optional seasoning (any one of the following):

2 tsp ground coriander      1/2-1 tsp dried marjoram      1 tsp dried basil  
 1/4 to 1/2 tsp dried oregano      1 to 2 tsp salt

- Heat the olive oil in a large saucepan
- Cover and cook the onions, celery, and carrots over medium-low heat for about 15 minutes, stir occasionally
- Uncover and stir over heat for an additional 5 to 10 minutes, or until the vegetables are soft and slightly golden
- Add the tomato sauce, sugar, and pepper
- Cover and simmer gently for 15 minutes
- Serve or allow to cool then refrigerate or freeze

12. Attach the **Waste Funnel** to the end of the **Screen** by pushing the small end with the tabs over the end of the **Screen**. **NOTE: Use caution not to break the Waste Funnel when attaching or detaching.**

13. Attach the **Squirt Guard/Chute** to the **Screen** by sliding the **Squirt Guard/Chute** over the **Screen** with the larger opening of the **Squirt Guard/Chute** closest to the **Hopper**. **Snap** it into place. *Figure E*

14. Attach the **Hopper** to the top of the **Roma** by sliding the small neck section of the **Hopper** into the throat of the **Body**.

15. Before placing any food in the **Hopper** be sure to have a bowl or jar under both the **Waste Funnel** and the **Squirt Guard/Chute**. *Figure F*

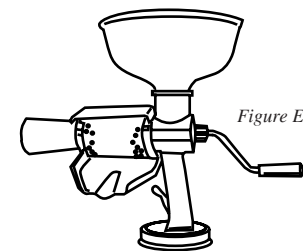

Figure E

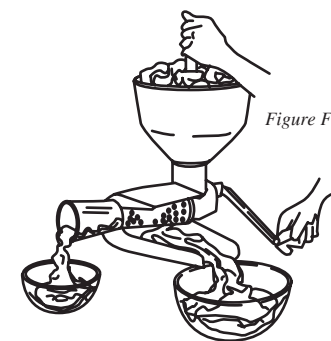

Figure F

**WARNING!**

**NEVER** use fingers to push food into the **Hopper**. **ALWAYS** use the provided **Stomper**.

## FOOD TIPS

**TOMATOES:** The **Food Strainer & Sauce Maker** will easily puree fresh tomatoes, remove the seeds, core and skin with no pre-cooking whatsoever. Fresh vine ripened tomatoes work best. Remove the stems, wash and quarter the tomatoes, then load the **Hopper** half way full with the quartered tomatoes. Guide the tomatoes into the neck of the **Food Strainer & Sauce Maker** using the **Stomper**, turn the **Handle** in a clockwise direction. The skins and seeds will come out of the **Waste Funnel**, while the delicious puree slides into your bowl ready to be seasoned and eaten. If the tomatoes are extra pulpy, a little unripe or difficult to strain, parboil them to make them softer. After par boiling, allow to cool before straining. If excessive liquid backs up into the **Hopper** continue turning the **Handle** until the liquid runs through the machine before guiding more tomatoes into the neck of the **Strainer**.

**APPLES AND PEARS:** For best results apples and pears should be softened before processing with the **Food Strainer & Sauce Maker**. This is easily accomplished without peeling or even coring the apples! Quarter the fruit before or after softening. Place the fruit in a pot with about 1/2 full of water. Set the heat to medium, cover, and let them steam until they are soft. For a little extra flavor you can use cider to steam the apples. After removing the fruit from the pot, strain it through the **Food Strainer & Sauce Maker** using the standard **Screen**. The cores, skins and seeds will come out of the **Waste Funnel**, while the delicious puree slides into your bowl ready to be seasoned and eaten. If the **Food Strainer & Sauce Maker** is too hard to turn, or it jams, the fruit may need further softening.

**BERRIES:** The **Food Strainer & Sauce Maker** will make it easy to create homemade jams and jellies. Combine different berries and fruits to create custom flavors. With the optional **Berry Screen** (Model No. 07-0855 sold separately) you can easily separate even the tiniest seeds from raspberries and strawberries. If you like your jellies thicker just add a few crushed berries to the puree or use a **Screen** with larger holes.

**PUMPKIN, SQUASH, POTATOES, ETC:** Using the optional **Pumpkin Screen** (Model No. 07-0857 sold separately) creates incredibly smooth pie fillings or purees. Use this **Screen** to also make breads, cakes, or even mashed potatoes without peeling. Just cut these products into 1" (2.5 cm) squares or slices. Boil or bake until tender. Allow to cool. For pumpkin and squash scoop the pulp out of its skin and run it through the **Food Strainer & Sauce Maker**. Potatoes can be cut into cubes, boiled until tender then run right through the **Food Strainer & Sauce Maker** for super smooth or chunky mashed potatoes with no peeling.

**GRAPES:** Using the optional **Grape Spiral** (Model No. 07-0856 sold separately) and standard **Screen**, to create gallons of delicious grape juice in just minutes. Just wash the grapes, pull them from the stems, and the **Food Strainer & Sauce Maker** does the rest. Great for the home wine maker.

**FRUITS WITH LARGER PITS:** For fruits like peaches, cherries, mangos, avocados\*, and anything else with a large seed, you must remove the seed to prevent jamming the mechanism. Don't worry about the skin or the core, the **Food Strainer & Sauce Maker** will easily remove them and send them out through the **Waste Funnel**. If the fruit is firm like an apple or pear, remember to soften them by steaming or baking slightly before loading them into the **Food Strainer & Sauce Maker**. \*Avocados must be peeled before straining.

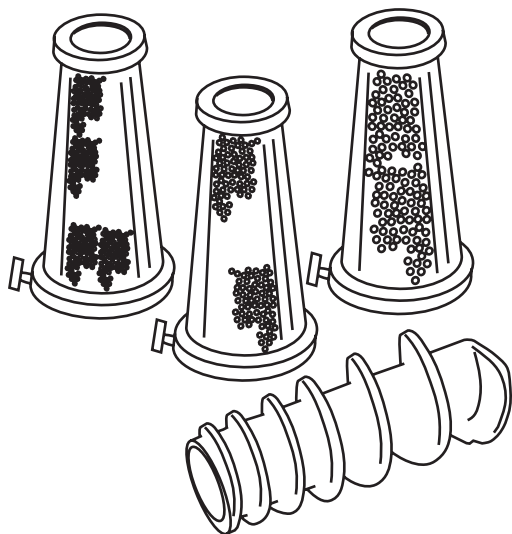

## CLEANING INSTRUCTIONS

1. Fully disassemble the **Food Strainer & Sauce Maker**.
2. Wash all parts in hot soapy water. A stiff-bristled bottle brush may be needed to clean the **Screen**. Pay extra attention to the seams of the **Screen** as seeds and skin may gather there.
3. Before storing or reassembling the **Food Strainer & Sauce Maker** be sure all the parts are thoroughly dry. It is recommended to apply a drop of vegetable oil on the rubber **Screen Gasket** to keep it from drying and becoming brittle.
4. Keep the box the **Food Strainer & Sauce Maker** came in for easy storage.

## HELPFUL HINTS

- It is normal when straining large quantities of food with a high moisture content like tomatoes, to see liquid back up into the **Hopper**. Simply continue turning the **Handle** until all the liquid disappears from the **Hopper** and neck of the **Food Strainer & Sauce Maker**.
- Depending on the food you are processing, it may be necessary to occasionally scrape pulp from the **Screen** of the **Food Strainer & Sauce Maker**. A rubber spatula is ideal for this.
- The **Food Strainer & Sauce Maker** is equipped with an extra **Large Hopper**. It is best to fill the **Hopper** half full leaving space around the middle to guide food into the throat of the **Food Strainer & Sauce Maker** using the **Stomper**.
- If there is excessive pulp exiting the **Waste Funnel**, run the pulp through the **Food Strainer & Sauce Maker** a second time to fully extract every bit of juice. To get the most out of the fruits and vegetables, strain the skins and seeds from the **Waste Funnel** a second time.
- Operating the **Food Strainer & Sauce Maker** while empty is not recommended. The juice from the fruits and vegetables act as a lubricant for the mechanism and reduces wear on the components.
- The standard **Screen** that comes with the **Food Strainer & Sauce Maker** is ideal for most foods, such as: Apples\*, Tomatoes, Apricots\*, Avocados (*must be peeled*), Carrots\*, Cherries, Cranberries\*, Peaches (*remove pit before straining*), Potatoes\*, Pears\*. \*These foods should be softened by steaming, par boiling or baking before straining.
- **IMPORTANT NOTE: ALWAYS FOLLOW RECOMMENDED CANNING, FREEZING AND DEHYDRATING PROCEDURES WHEN PRESERVING ANY FOODS.**

**CAUTION!** It is important to follow the "Food Safety" guidelines outlined in this manual. For the most up to date instruction visit the USDA website.

## ADDITIONAL ACCESSORIES AVAILABLE

4-Piece Strainer Accessory Kit	07-0858
Berry Screen	07-0855
Pumpkin Screen	07-0857
Salsa Screen	07-0869
Grape Spiral	07-0856
Two-Speed Electric Motor Attachment	01-0101

These products and many more products can be ordered by visiting **WestonProducts.com** or by calling Weston Products LLC Toll Free at 1-800-814-4895 Monday thru Friday 8:00am-5:00pm EST. Outside the U.S. call 440-638-3131