



Yes, you can.®



# **Invacare® Storm<sup>4</sup> Max**

---

***Power wheelchair  
User manual***





## How can you get in touch with Invacare®?

If you have any questions or need support, please contact your authorised Invacare® Dealer, who has the necessary know-how and equipment plus the special knowledge concerning your Invacare® product, and can offer you all-round satisfactory service. Should you wish to contact Invacare® directly, you can reach us in Europe at the following addresses and phone numbers.

<b>A</b>	<b>Invacare Austria GmbH</b> Herzog Odilostrasse 101 A-5310 Mondsee Austria	☎: Fax: @: WWW:	+43 6232 5 53 50 +43 6232 5 53 54 info@invacare-austria.com www.invacare.at
----------	--	--------------------------	--

<b>B</b>	<b>Invacare n.v.</b> Autobaan 22 B-8210 Loppem (Brugge) <b>Belgium</b>	☎: Fax: @: WWW:	+32 (0)50 83 10 10 +32 (0)50 83 10 11 belgium@invacare.com www.invacare.be
----------	---	--------------------------	---

<b>CH</b>	<b>Invacare AG</b> Benkenstraße 260 CH-4108 Witterswil <b>Switzerland</b>	☎: Fax: @: WWW:	+41 (0)61487 70 80 +41 (0)61487 70 81 switzerland@invacare.com www.invacare.ch
-----------	--	--------------------------	---

<b>D</b>	<b>Invacare GmbH</b> Alemannenstraße 10 88316 Isny <b>Deutschland</b>	☎: Fax: @: WWW:	+49 (0)7562 70 00 +49 (0)7562 7 00 66 kontakt@invacare.com www.invacare.de
----------	--	--------------------------	---

<b>DK</b>	<b>Invacare A/S</b> Sdr. Ringvej 37 DK-2605 Brøndby <b>Danmark</b>	☎ (Kundeservice): Fax (Kundeservice): @: WWW:	+45 (0)36 90 00 00 +45 (0)36 90 00 01 denmark@invacare.com www.invacare.dk
-----------	---	--	---

<b>E</b>	<b>Invacare® SA</b> c/ Areny s/n Polígon Industrial de Celrà E-17460 Celrà (Girona) <b>ESPAÑA</b>	☎: Fax: @: WWW:	+34 (0)972 49 32 00 +34 (0)972 49 32 20 contactsp@invacare.com www.invacare.es
----------	---	--------------------------	---

<b>F</b>	<b>Invacare® Poirier SAS</b> Route de St Roch F-37230 Fondettes <b>France</b>	☎: Fax: @: WWW:	+33 (0)247 62 64 66 +33 (0)247 42 12 24 contactfr@invacare.com www.invacare.fr
<b>GB</b>	<b>Invacare® Ltd</b> Pencoed Technology Park Pencoed Bridgend CF35 5AQ United Kingdom	☎ (Customer services): Fax (Customer services): @: WWW:	+44 (0)1656 77 62 22 +44 (0)1656 77 62 20 uk@invacare.com www.invacare.co.uk
<b>I</b>	<b>Invacare Mecc San s.r.l.</b> Via dei Pini, 62 I - 36016 Thiene (VI) <b>ITALIA</b>	☎: Fax: @: WWW:	+39 0445 38 00 59 +39 0445 38 00 34 italia@invacare.com www.invacare.it
<b>IE</b>	<b>Invacare Ireland Ltd.</b> Unit 5 Seatown Business Campus Seatown Rd, Swords County Dublin <b>Ireland</b>	☎: Fax: @: WWW:	+353 18 10 70 84 +353 18 10 70 85 ireland@invacare.com www.invacare.ie
<b>N</b>	<b>Invacare® AS</b> Grensesvingen 9 Postboks 6230 Etterstad N-0603 Oslo <b>Norge</b>	☎ (Kundeservice): Fax (Kundeservice): @: @: WWW:	+47 (0)22 57 95 00 +47 (0)22 57 95 01 norway@invacare.com island@invacare.com www.invacare.no
<b>NL</b>	<b>Invacare® B.V.</b> Celsiusstraat 46 NL-6716 BZ Ede <b>Nederland</b>	☎: Fax: @: @: WWW:	+31 (0)318 69 57 57 +31 (0)318 69 57 58 nederland@invacare.com csede@invacare.com www.invacare.nl
<b>P</b>	<b>Invacare Lda</b> Rua Estrada Velha, 949 P-4465-784 Leça do Balio Portugal	☎: ☎: Fax: @: WWW:	+351 225 10 59 46 +351 225 10 59 47 +351 225 10 57 39 portugal@invacare.com www.invacare.pt



**Invacare® AB**  
Fagerstagatan 9  
S-163 91 Spånga  
**Sverige**



☎ (Kundtjänst): +46 (0)8 761 70 90  
Fax (Kundtjänst): +46 (0)8 761 81 08  
@: sweden@invacare.com  
@: finland@invacare.com  
WWW: www.invacare.se

**MÖLNDAL**

☎: +46 (0)31 86 36 00  
Fax: +46 (0)31 86 36 06  
@: ginvacare@invacare.com

**LANDSKRONA**

☎: +46 (0)418 2 85 40  
Fax: +46 (0)418 1 80 89  
@: linvacare@invacare.com

**OSKARSHAMN**

☎: +46 (0)491 1 01 40  
Fax: +46 (0)491 1 01 80  
@: oinvacare@invacare.com

---

**Eastern  
european  
countries**

**European Distributor  
Organisation (EDO)**  
Kleiststraße 49  
D-32457 Porta Westfalica  
**Deutschland**

☎: +49 (0)5731 75 45 40  
Fax: +49 (0)5731 75 45 41  
@: edo@invacare.com  
WWW: www.invacare.de

---

# Table of Contents

Chapter		Page
<b>1</b>	<b>Introduction</b>	<b>10</b>
1.1	Important symbols in this manual .....	11
1.2	Important symbols found on the vehicle .....	13
1.3	Type classification and permissible use.....	15
1.4	Indications.....	15
1.5	Usability.....	16
1.6	Warranty .....	17
1.7	Life expectancy.....	17
<b>2</b>	<b>Safety notes</b>	<b>18</b>
2.1	General safety notes .....	18
2.2	Safety information with regard to care and maintenance .....	21
2.3	Safety information on electromagnetic interference .....	22
2.4	Safety information on driving and freewheel mode.....	23
2.5	Safety information regarding changes and modifications to the mobility device.....	25
<b>3</b>	<b>Key features</b>	<b>27</b>
<b>4</b>	<b>The position of the labels on the product</b>	<b>28</b>
<b>5</b>	<b>Getting in and out of the wheelchair</b>	<b>29</b>
5.1	Removing the armrests to get in .....	29
5.2	Information about getting in and out.....	30
5.3	Using the cane holder .....	31
<b>6</b>	<b>Driving</b>	<b>32</b>

6.1	<b>Before driving for the first time</b> .....	<b>32</b>
6.2	<b>Parking and stationary</b> .....	<b>33</b>
6.3	<b>Taking Obstacles</b> .....	<b>33</b>
6.3.1	Maximum obstacle height.....	33
6.3.2	Safety information when ascending obstacles.....	33
6.3.3	The correct way to overcome obstacles.....	34
6.4	<b>Driving up and down gradients</b> .....	<b>35</b>
6.5	<b>Use on public roads</b> .....	<b>35</b>
<b>7</b>	<b>Pushing the mobility device in freewheel mode</b>	<b>36</b>
7.1	Disengaging motors.....	36
<b>8</b>	<b>Remotes</b>	<b>37</b>
<b>9</b>	<b>Adjusting the wheelchair to the user's seating posture</b>	<b>38</b>
9.1	<b>Adjustment possibility for control panel</b> .....	<b>39</b>
9.1.1	Adjust the control panel for the length of the user's arm (all seat systems).....	39
9.1.2	Adjusting the height of the remote (only for foldable remote holders).....	40
9.1.3	Swivelling the remote to the side.....	41
9.2	<b>Adjustment facilities for standard armrests</b> .....	<b>42</b>
9.2.1	Changing the armrest position.....	42
9.2.2	Setting the height of the armrests.....	43
9.2.3	Adjusting the width of the armrests.....	44
9.3	<b>Adjusting the seat angle</b> .....	<b>45</b>
9.3.1	Electric.....	45
9.3.2	Manually using spindle.....	45
9.4	<b>Adjusting the seat depth</b> .....	<b>47</b>
9.5	<b>Adjusting the backrest</b> .....	<b>50</b>
9.5.1	Electric.....	50
9.5.2	Manual.....	51
9.5.3	Adjusting the tension adjustable backrest upholstery.....	53

	9.5.4	Adjusting the backrest bend .....	54
<b>9.6</b>		<b>Adjusting the headrest.....</b>	<b>59</b>
	9.6.1	Adjusting the position of the headrest or neckrest .....	60
	9.6.2	Adjusting the height of the headrest or neckrest .....	61
	9.6.3	Adjusting the cheek supports .....	62
<b>9.7</b>		<b>Postural belts .....</b>	<b>62</b>
	9.7.1	Types of postural belts.....	63
	9.7.2	Adjusting the postural belt correctly.....	63
<b>9.8</b>		<b>Adjusting or removing the luggage carrier.....</b>	<b>65</b>
<b>9.9</b>		<b>Using the KCLICKfix adapter .....</b>	<b>66</b>
<b>9.10</b>		<b>Legrests.....</b>	<b>67</b>
	9.10.1	General adjustments.....	67
	9.10.1.1	Adjusting the length of the legrest .....	67
	9.10.1.2	Adjusting the height of the calf pad .....	69
	9.10.1.3	Adjusting the calf pad width.....	71
	9.10.2	Vari-F footrest .....	72
	9.10.2.1	Swivelling the footrest outward and/or removing.....	72
	9.10.2.2	Setting the angle.....	73
	9.10.2.3	Setting the end stop of the footrest .....	75

## **10 Electrical system 78**

<b>10.1</b>		<b>Electronics protection system .....</b>	<b>78</b>
<b>10.2</b>		<b>Batteries .....</b>	<b>79</b>
	10.2.1	Charging the batteries .....	79
	10.2.1.1	General information on charging .....	79
	10.2.1.2	General instructions on charging.....	79
	10.2.1.3	How to charge the batteries.....	80
	10.2.1.4	How to disconnect the batteries after charging .....	81
	10.2.2	Storage and Maintenance.....	82
	10.2.3	Instructions on using the batteries.....	82
	10.2.4	Transporting batteries.....	84



10.2.5	Handling batteries .....	84
10.2.5.1	General instructions on handling the batteries .....	84
10.2.5.2	How to handle damaged batteries correctly .....	84
<b>11</b>	<b>Maintenance</b>	<b>86</b>
11.1	<b>Cleaning the mobility device</b> .....	<b>86</b>
11.2	<b>Inspection checks</b> .....	<b>87</b>
11.2.1	Before each use of the mobility device .....	88
11.2.2	Weekly .....	89
11.2.3	Monthly .....	90
11.3	<b>Repair Instructions</b> .....	<b>91</b>
11.3.1	Repairing a flat tyre .....	91
11.3.2	Repairing a flat tyre at the front (tyre type 3.00x4") .....	92
11.3.3	Repairing tyre punctures (drive wheel) .....	94
<b>12</b>	<b>Transport</b>	<b>97</b>
12.1	<b>Transferring the wheelchair to a vehicle</b> .....	<b>97</b>
12.2	<b>Use of the wheelchair as a seat in a vehicle</b> .....	<b>98</b>
12.2.1	How the wheelchair is anchored in a vehicle for use as a vehicle seat .....	101
12.2.2	How the user is secured within the wheelchair .....	102
12.3	<b>Securing the wheelchair for transport without passengers</b> .....	<b>106</b>
12.3.1	Opening the rear cover .....	107
12.3.2	Making the batteries accessible .....	108
12.3.3	Removing/Installing the batteries .....	112
<b>13</b>	<b>Refurbishment</b>	<b>114</b>
<b>14</b>	<b>Disposal</b>	<b>114</b>
<b>15</b>	<b>Technical specifications</b>	<b>115</b>
<b>16</b>	<b>Inspections Performed</b>	<b>119</b>

# 1 Introduction

Dear user,

First we would like to thank you for purchasing our product! We hope that you will have a great deal of pleasure with your new power wheelchair.

**This operating manual contains important information and notes about:**

- **Safety**
- **Operation**
- **Care and maintenance**

**Please take care to read the operating manual thoroughly before starting out on your first journey.**

If you find that the font size in the print version of the user manual is difficult to read, you can download it as a pdf from the Invacare website. This can then be scaled on screen to a font size that is more comfortable for you.

This wheelchair has been constructed for a large circle of users with different requirements.

The decision whether the model is suitable for the user may only be taken by medical specialists with appropriate expertise.

Invacare® or their statutory representatives can accept no liability in cases in which the wheelchair has not been adapted to suit the users' handicaps.

Some maintenance and settings can be performed by the user or his/hers attendants. Certain adjustments do however require technical training and may only be carried out by your Invacare® specialist dealer. Damages and errors caused by nonobservance of the user manual or as a result of incorrect maintenance are excluded from all guarantees.

This manual contains copyrighted information. This manual may not be reproduced or reprinted either partly or completely without previous written consent from Invacare® or its statutory representatives. We reserve the right to make any necessary alterations on the grounds of technical improvements.

## 1.1 Important symbols in this manual

---



### **General risks**

**This symbol warns you of general hazards!**

- *Always follow the instructions to avoid injury to the user or damage to the product.*
- 



### **EXPLOSION HAZARD!**

**This symbol warns you of an explosion hazard, which can be caused by excessive tyre pressure in a pneumatic tyre.**

- *Always follow the instructions to avoid injury to the user or damage to the product.*
- 



### **BURN HAZARD!**

**This symbol warns you of the danger of chemical burns, for example due to the discharge of battery acids!**

- *Always follow the instructions to avoid injury to the user or damage to the product.*
-



---

### **BURN Risk!**

**This symbol warns of the risk of burns, for example, as a result of hot motor surfaces.**

- *Follow the instructions in order to avoid injury or damage to the product.*
- 



---

### **RISK OF CRUSHING!**

**This symbol warns of a risk of crushing caused by being careless with heavy components.**

- *Always follow the instructions to avoid injury to the user or damage to the product.*
- 



---

### **Wear eye protection**

**This symbol refers to the requirement for wearing eye protection, for example when working with batteries.**

- *You must wear safety goggles when this symbol is displayed.*
- 



---

### **Wear protective gloves**

**This symbol indicates the requirement to wear protective gloves, for example when working with batteries.**

*You must wear protective gloves when this symbol is displayed.*

---



---

### **NOTE:**

This symbol identifies general information which is intended to simplify working with your product and which refers to special functions.

---



---

**Requirements:**

- This symbol identifies a list of various tools, components and items which you will need in order to carry out certain work. Please do not attempt to carry out the work if you do not have the listed tools available.
- 



---

**READ WELL BEFORE OPERATION!**

This symbol advises you to read information carefully.

---

## 1.2 Important symbols found on the vehicle



---

**This product has been supplied from an environmentally aware manufacturer. This product may contain substances that could be harmful to the environment if disposed of in places (landfills) that are not appropriate according to legislation.**

- *The 'crossed out wheelie bin' symbol is placed on this product to encourage you to recycle wherever possible.*
  - *Please be environmentally responsible and recycle this product through your recycling facility at its end of life.*
- 



---

**This symbol indicates the “Drive” position of the coupling lever. In this position the motor is engaged and the motor brakes are operational. You can drive the wheelchair.**

- *Please note that for driving purposes both motors must always be engaged.*



This symbol indicates the “Push” position of the coupling lever. In this position the motor is disengaged and the motor brakes are not operational. The wheelchair can be pushed by an attendant and the wheels turn freely.

- *Please note that the control panel must be switched off.*
  - *Please also note the information provided in section "**Pushing the mobility device in freewheel mode**" on page 36.*
- 



This symbol indicates the position of an anchor point when using a lashing system during transport.

---



If the symbol appears on a bright yellow sticker, the anchoring point is suitable for fixation of the wheelchair in a vehicle for use as a vehicle seat.

---



**This wheelchair may not be used as a vehicle seat!**

- *This wheelchair does not satisfy the requirements of ISO 7176-19:2001 and may not under any circumstances be used as a vehicle seat or to transport the user in a vehicle.*
  - *Using a wheelchair that does not fulfill these criteria as a vehicle seat can lead to the most severe injuries and even death in the event of a traffic accident.*
-



---

**This wheelchair may be used as a vehicle seat, but only if it is equipped with a headrest that has been approved by Invacare for this purpose!**

- *Please always make sure that the wheelchair is equipped with a headrest approved by Invacare before using it as a vehicle seat!*
- 

### 1.3 Type classification and permissible use

This vehicle was designed for persons whose ability to walk is impaired, but who are still in terms of their eyesight and physically and mentally able to operate an electric vehicle. It has been classified according to EN 12184 as a **class B mobility product** (for indoor and outdoor areas). It is therefore compact and agile enough for indoor areas, but also able to overcome many obstacles in outdoor areas.

You can find precise information about speed, turning radius, driving range, maximum safe slope, maximum obstacle height and permissible operating conditions in chapter "Technical specifications" starting from page 115.

Please also pay attention to all safety information in chapter "Safety notes" starting from page 18.

The vehicle was successfully tested according to German and international standards as to its safety. It satisfies the requirements according to DIN EN 12184 including EN 1021-1/-2. It was also tested successfully according to EN60529 IPX4 as to its resistance to spray water, and is therefore well suited for typical middle European weather conditions. When equipped with an appropriate lighting system, the vehicle is suitable for use on public roads.

### 1.4 Indications

The use of this mobility product is recommended for the following indications:

The inability or a greatly restricted ability to walk within the scope of the basic requirement to be able to move within one's own four walls. The need to leave the dwelling place in order to get some fresh air during a short walk or to reach those places generally to be found at close distance to the dwelling and where everyday business is carried out.

Provision of power wheelchairs for interior and exterior areas is advisable if the use of hand-operated wheelchairs is no longer possible on account of the disability, yet proper operation of an electromotive drive unit is still practicable.

## **1.5 Usability**

Only use a power wheelchair when it is in perfect working order. Otherwise, you might put yourself and others at risk.

The following list does not claim to be exhaustive. It is only intended to show some of the situations that could affect the usability of your power wheelchair.

In certain situations, you should immediately stop using your wheelchair. Other situations allow you to use the wheelchair to get to your dealer.

- You should immediately stop using your power wheelchair if its usability is restricted due to:
  - brake failure
- You should immediately contact an authorised Invacare® dealer if the usability of your power wheelchair is restricted due to:
  - the lighting system failing or being defective
  - reflectors falling off
  - worn thread or insufficient tyre pressure
  - damage to the armrests (e.g. torn armrest padding)



- damage to the legrest hangers (e.g. missing or torn heel loops)
- damage to the postural belt
- damage to the joystick (joystick cannot be moved into the neutral position)
- cables that are damaged, kinked, pinched or have come loose from the holder
- the wheelchair drifting when braking
- the wheelchair pulling to one side when moving
- unusual sounds developing or occurring

Or if you have the feeling that something is wrong with your wheelchair.

## **1.6 Warranty**

The terms and conditions of the warranty are part of the general terms and conditions particular to the individual countries in which this product is sold.

## **1.7 Life expectancy**

We estimate a life expectancy of five years for this product, provided it is used in strict accordance with the intended use as set out in this document and all maintenance and service requirements are met. The estimated life expectancy can be exceeded if the product is carefully used and properly maintained, and provided technical and scientific advances do not result in technical limitations. The life expectancy can also be considerably reduced by extreme or incorrect usage. The fact that we estimate a life expectancy for this product does not constitute an additional warranty.

## 2 Safety notes



---

**READ WELL BEFORE OPERATION!**

---

### 2.1 General safety notes

---



**Danger of injury if mobility device is used in any other way than the purpose described in this manual!**

- *Only ever use the mobility device in accordance with the instructions in this User's Manual (see chapter "Type classification and permissible use" on page 15).*
- *Pay strict attention to the safety information.*

**Danger of injury if the mobility device is driven when ability to operate a vehicle is impaired by medication or alcohol!**

- *Never drive the mobility device under the influence of medication or alcohol. If necessary, the mobility device must be operated by an attendant who is physically and mentally able.*

**Danger of damage or injury if mobility device is accidentally set into motion!**

- *Switch the mobility device off before you get in, get out or handle unwieldy objects.*
  - *When the drive is disengaged, the brake inside the drive is deactivated. For this reason, pushing the mobility device by an attendant is only recommended on flat surfaces, never on gradients. Never leave your mobility device on a gradient with its motors disengaged. Always re-engage the motors immediately after pushing the mobility device (see chapter "Pushing the mobility device in freewheel mode" on page 36).*
-



---

**Danger of injury if the mobility device is switched off while driving, for example by pressing the On/Off Button or disconnecting a cable, due to it coming to an abrupt, sharp stop!**

- *If you have to brake in an emergency, simply release the joystick which will bring you to a halt. (refer to the joystick operating manual for more information).*

**Danger of injury when transferring mobility device to a vehicle for transport with the occupant seated in it!**

- *It is always better to transfer the mobility device to a vehicle without the occupant seated in it.*
- *If the mobility device needs to be loaded up a ramp together with its driver, ensure that the ramp does not exceed the maximum safe slope (see chapter "Technical specifications" from page 115).*
- *If the mobility device does need to be loaded using a ramp which exceeds the maximum safe slope (see chapter "Technical specifications" from page 115), then you must use a winch. An attendant can safely monitor and assist the loading process.*
- *As an alternative you can use a platform lift. Ensure that the total weight of the mobility device including the user does not exceed the maximum permissible weight for the platform lift or winch if you are using.*

**Danger of injury if maximum permissible load is exceeded!**

- *Do not exceed the maximum permissible load (see chapter "Technical specifications" from page 115).*
  - *The mobility device is only designed for use by a single occupant whose maximum weight does not exceed the maximum permissible load of the device. Never use the mobility device to transport more than one person.*
-



---

**Danger of injury due to wrong lifting or dropping of heavy components!**

- *When maintaining, servicing or lifting any part of your mobility device, take into account the weight of the individual components especially the batteries. Be sure at all times to adopt the correct lifting posture and ask for assistance if necessary.*

**Danger of falling out of the mobility device.**

- *Do not slide forward on the seat, do not lean forward between your knees, do not lean backwards out over the top of the backrest, for example to reach an object.*
- *If a posture belt is installed, it should be correctly adjusted and used each time you use the mobility device.*
- *When transferring to a different seat, position the mobility device as close as possible to the new seat.*

**Danger of injury by moving parts!**

- *Make sure that no injury is incurred by moving parts of the mobility device, like wheels or one of the Lifter Modules (if fitted), especially when children are around.*

**Risk of injury from hot surfaces!**

- *Do not leave the wheelchair in direct sunlight for prolonged periods. Metal parts and surfaces such as the seat and armrests can become very hot.*

**Danger of fire or breaking down due to electric devices being connected!**

- *Do not connect any electric devices to your mobility device that are not expressly certified by Invacare® for this purpose. Have all electrical installations done by your authorised Invacare® Dealer.*
-

## 2.2 Safety information with regard to care and maintenance

---



### **Danger of accident and loss of guarantee if maintenance is insufficient!**

- *For reasons of safety and in order to avoid accidents which result from unnoticed wear, it is important that this electric mobility product undergoes an inspection once every year under normal operating conditions (see inspection plan contained in service instructions).*
  - *Under difficult operating conditions such as daily travel on steep slopes, or in the case of use in medical care cases with frequently changing wheelchair users, it would be expedient to carry out intermediate checks on the brakes, accessories and running gear.*
  - *If the mobility product is to be operated on public roads, the vehicle driver is responsible for ensuring that it is in an operationally reliable condition. Inadequate or neglected care and maintenance of the mobility product will result in a limitation of the manufacturer's liability.*
-

## 2.3 Safety information on electromagnetic interference

This electric vehicle was successfully tested in accordance with International standards as to its compliance with Electromagnetic Interference (EMI) regulations. However, electromagnetic fields, such as those generated by radio and television transmitters, and cellular phones can influence the functions of electric vehicles. Also, the electronics used in our vehicles can generate a low level of electromagnetic interference, which however will remain within the tolerance permitted by law. For these reasons we ask you to please observe the following precautions:



---

**WARNING: Danger of malfunction due to electromagnetic interference!**

- *Do not switch on or operate portable transceivers or communication devices (such as radio transceivers or cellular phones) when the vehicle is switched on.*
  - *Avoid getting near strong radio and television transmitters.*
  - *In case the vehicle should be set in motion unintentionally or the brakes are released, switch it off immediately.*
  - *Adding electrical accessories and other components or modifying the vehicle in any way can make it susceptible to electromagnetic interference. Keep in mind that there is no sure way to determine the effect such modifications will have on the overall immunity of the electronic system.*
  - *Report all occurrences of unintentional movement of the vehicle, or release of the electric brakes to the manufacturer.*
-

## 2.4 Safety information on driving and freewheel mode

---



### **Danger of injury if the wheelchair tips over!**

- *Inclines and declines can only be travelled up to the maximum safe slope (see chapter "Technical specifications" from page 115).*
  - *Always return the backrest of your seat or the seat tilt to an upright position before ascending slopes. We recommend that you position the seat backrest and the seat tilt (if fitted) slightly to the rear before descending slopes.*
  - *Only ever drive downhill at a maximum of 2/3 of the top speed. Avoid abrupt braking or accelerating on gradients.*
  - *If at all possible, avoid driving on slippery surfaces (such as snow, gravel, ice etc.) where there is a danger of you losing control over the vehicle, especially on a gradient. If driving on such a surface is inevitable, then always drive slowly and with the utmost caution.*
  - *Never attempt to overcome an obstacle when on an uphill or downhill gradient.*
  - *Never attempt to drive up or down a flight of steps with your wheelchair.*
  - *When overcoming obstacles, always observe the maximum obstacle height (see chapter "Technical specifications" from page 115 and information about overcoming obstacles in chapter "Taking Obstacles" from page 33).*
  - *Avoid shifting your centre of gravity as well as abrupt joystick movements and changes of direction when the wheelchair is in motion.*
  - *Never use the wheelchair to transport more than one person.*
  - *Do not exceed the overall maximum permissible load or the maximum load per axle (see chapter "Technical specifications" on page 115).*
  - *Note that the wheelchair will brake or accelerate if you change the Driving Mode whilst the wheelchair is in motion.*
-



---

**Danger of breaking down in adverse weather conditions, i.e. extreme cold, in an isolated area!**

- *If you are a user with severely limited mobility, we advise that in the case of adverse weather conditions DO NOT attempt a journey without an accompanying attendant!*

**Danger of injury if your foot slides off the footrest and gets caught underneath the wheelchair when it is in motion!**

- *Make sure each time before you drive the wheelchair that your feet are squarely and securely in place on the footplates, and that both legrests are properly locked into place.*

**Danger of injury if you collide with an obstacle when driving through narrow passages such as doorways and entrances!**

- *Drive through narrow passages in the lowest driving mode and with due caution.*

**If your power wheelchair has been fitted with angle-adjustable legrests, there is a danger of personal injury and damage to the wheelchair if you drive the wheelchair with the legrests raised!**

- *To avoid unwanted displacement of the wheelchair centre of gravity to the front (especially when travelling downhill) and in order to avoid damage to the wheelchair, angle-adjustable legrests must always be lowered during normal travelling.*
- 



---

**CAUTION: Danger of tipping! Anti tip wheels (stabilisers) are only effective on firm ground! They sink in on soft ground such as grass, snow or mud if the mobility device rests itself on them. They lose their effect and the mobility device can tip over.**

- *Only drive with extreme care on soft ground, especially during uphill and downhill journeys. In the process pay increased attention to the tip stability of the mobility device.*
-



## 2.5 Safety information regarding changes and modifications to the mobility device

---



### **CE marking of the wheelchair**

The conformity assessment/ CE marking was carried out in accordance with Directive 93/42 EEC / MPG (Medical Devices Act) and only applies to the complete product.

The CE marking is invalidated if components or accessories are replaced or added that have not been approved for this product by Invacare.

In this case, the company that adds or replaces the components or accessories is responsible for the conformity assessment/ CE marking or for registering the wheelchair as a special design and for the relevant documentation.

---



---

**CAUTION: Danger of injuries and damage to mobility aid due to unapproved components and accessory parts!**

**Seating systems, additions and accessory parts which have not been approved by Invacare® for use with this mobility aid can affect the tipping stability and increase tipping hazards!**

- *Only ever use seating systems, additions and accessory parts which have been approved by Invacare® for this mobility aid!*

**Seating systems which are not approved by Invacare® for use with this power wheelchair do not, under certain circumstances, comply with the valid standards and could increase the flammability and the risk of skin irritation.**

- *Only use seating systems that have been approved by Invacare® for this power wheelchair.*

**Electrical and electronic components which have not been approved by Invacare® for use with this mobility aid can cause fire hazards and lead to electromagnetic damage!**

- *Only ever use electrical and electronic components which have been approved by Invacare® for this mobility aid!*

**Batteries which have not been approved by Invacare® for use with this mobility aid can cause chemical burns!**

- *Only ever use batteries which have been approved by Invacare® for this mobility aid!*
-

### 3 Key features

- 1) Headrest
- 2) Backrest
- 3) Armrest
- 4) Battery case (rear)
- 5) Drive wheel
- 6) Drive motor (with engaging lever)
- 7) Remote
- 8) Legrests
- 9) Castor wheel
- 10) Suspension, rear (both not visible in illustration)



## 4 The position of the labels on the product

- 1) Identification of the lashing eyes at the front and back  
Warning that the wheelchair may not be used as a vehicle seat  
Note on required head support if the wheelchair may be used as a vehicle seat
- 2) Identification label sticker on the chassis at the rear right (also included in the pass card)
- 3) Identification of the position of the coupling lever for driving and push operation



The symbols on the labels are explained in section "**Important symbols found on the vehicle**" on page **13**.

## 5 Getting in and out of the wheelchair



---

**Important information for getting into and out of the wheelchair from the side!**  
The armrest must be removed in order to get into or out of the wheelchair from the side.

---

### 5.1 Removing the armrests to get in

If you want to get out on the side where the remote is installed, you can disconnect the remote cable from the remote (depending on your version).

#### Removing the armrest:

- The remote cable can be disconnected from the remote depending on the remote version.
- Loosen clamping lever (1)
- Remove the side panel from the receptacle



## 5.2 Information about getting in and out

### Getting into the wheelchair:

- Position your wheelchair as close as possible to your seat. This might have to be done by an attendant.
- Switch your wheelchair off.
- Apply the manual wheel lock of your wheelchair (if existing).
- Detach the skirt guard of your wheelchair or swivel it up.
- Now slide into the wheelchair.



### Getting out of the wheelchair:

- Drive your wheelchair as close as possible to your seat.
- Switch your wheelchair off.
- Apply the manual wheel lock of your wheelchair (if existing).
- Detach the skirt guard of your wheelchair or swivel it up.
- Now slide onto your new seat.



---

#### **NOTE:**

If you do not have sufficient muscle strength, you should ask other persons for help. Use a sliding board, if possible.

---

## 5.3 Using the cane holder

If your mobility device is fitted with a cane holder, it can be used for the safe transport of a walking cane, underarm or forearm crutches. The cane holder consists of a plastic container (bottom) and a Velcro fastener (top).



---

**WARNING! Risk of injury! A walking cane or crutches that are not secured during transport (on the user's lap, for example) can cause injury to the user or other persons!**

- *During transport, walking canes or crutches should always be secured using a cane holder!*
- 

- Open the upper Velcro fastener.
- Place the lower end of the walking cane or the crutches in the container at the bottom.
- The walking cane or the crutches can be secured at the upper end using the Velcro fastener.

## 6 Driving

---



### NOTE

The maximum load capacity that is stated in the technical data only states that the system is designed for this mass in total. However, this does not mean that one can sit a person with this body weight in the wheelchair without restrictions. Attention must be paid to the body proportions, such as height, weight distribution, abdominal girth, leg and calf girth and seat depth. These factors have a strong influence on driving features such as tilt stability and traction. The permissible axle loads in particular must be adhered to (see chapter "**Technical specifications**" as from page 115)! It may possibly be necessary to carry out adaptations to the seat system.

---

### 6.1 Before driving for the first time...

Before you take your first trip, you should familiarise yourself well with the operation of the vehicle and with all operating elements. Take your time to test all functions and driving modes.

---



### NOTE:

If installed, make sure to properly adjust and use the postural belt each time you use the wheelchair.

---

#### **Sitting Comfortably = Driving Safely**

**Before each trip, make sure that:**

- **You are within easy reach of all operating controls.**
- **The battery charge is sufficient for the distance intended to be covered.**
- **The postural belt (if installed) is in perfect order.**



- The rear mirror (if installed) is adjusted so you can look behind at all times without having to bend forward or shift your seating position.

## 6.2 Parking and stationary

**When parking your vehicle or if your vehicle is stationary for a prolonged period:**

- Switch the vehicle's power system off (ON-/OFF key).
- Activate your anti-theft lock, if existing.

## 6.3 Taking Obstacles

### 6.3.1 Maximum obstacle height

You can find information about maximum obstacle heights in the chapter entitled "**Technical specifications**" from page **115**.

### 6.3.2 Safety information when ascending obstacles



---

**CAUTION: Danger of Tipping Over!**

- *Never approach obstacles at an angle but at 90 degrees as shown below.*
  - *Put your backrest into an upright position before climbing an obstacle.*
-



---

**ATTENTION: Risk of falling out of the chair and damage to the power wheelchair such as broken castors!**

- *Never approach obstacles that are higher than the maximum climbable obstacle height. For the maximum climbable obstacle height, see "Technical specifications" on page 115.*
  - *If unsure whether the kerb climb is possible or not, move away from the obstacle and if possible find another location.*
- 

### 6.3.3 The correct way to overcome obstacles

#### Ascending

- Approach the obstacle or the kerb slowly, head-on and at a right angle.
- Depending on the wheel drive type, stop in one of the following positions:
  - In the case of centrally driven wheelchairs: 5 - 10 cm before the obstacle.
  - For all other drives: approx. 30 - 50 cm in front of the obstacle.
- Check the position of the front wheels. They must be in driving direction and at right angles to the obstacle.
- Approach slowly and keep at a consistent speed until the rear wheels have also passed over the obstacle.

#### Descending

The approach to descend an obstacle is the same as to ascend it with the difference that you need not stop before descending.

- Descend the obstacle very slowly.

#### Right



#### Wrong



## 6.4 Driving up and down gradients

For information concerning the maximum safe slope, please see chapter "**Technical specifications**" starting on page 115.



---

### **WARNING: Danger of tipping over!**

- *Only ever drive downhill at a maximum of 2/3 of the top speed. Avoid sudden changes of direction or abrupt braking when driving on slopes.*
  - *Always return the backrest of your seat or the seat tilt (if adjustable seat tilt is available) to an upright position before ascending slopes. We recommend that you position the seat backrest or the seat tilt slightly to the rear before descending slopes.*
  - *Always lower the lifter (if fitted) to its lowest position before ascending or descending a slope.*
  - *Never attempt to ascend or descend a slope on slippery surfaces or where there is a danger of skidding (such as wet pavement, ice etc).*
  - *Avoid trying to get out of the vehicle on an incline or a gradient.*
  - *Always drive straight in the direction the road or path you are on goes, rather than attempting to zigzag.*
  - *Never attempt to turn around on an incline or a slope.*
- 



---

### **Braking distance is much longer on a downhill slope than on even terrain!**

- *Never drive down a slope that exceeds the maximum safe slope (see chapter "**Technical specifications**" on page 115).*
- 

## 6.5 Use on public roads

If you wish to use your wheelchair on public roads and lighting is required by national legislation, then your wheelchair needs to be equipped with an appropriate lighting system.

Please contact your Invacare ® dealer if you have any questions.

## 7 Pushing the mobility device in freewheel mode

The motors of the wheelchair are equipped with automatic brakes, preventing that the wheelchair starts rolling out of control when the joystick box is switched off. When pushing the wheelchair manually whilst freewheeling, the magnetic brakes must be disengaged.



---

**NOTE:**

Pushing the wheelchair by hand may require more physical force than expected (more than 100 N). The necessary force nevertheless complies with the requirements of ISO 7176-14:2008.

---

### 7.1 Disengaging motors



---

**Danger of the vehicle running away!**

- *When the motors are disengaged (for push operation whilst freewheeling), the electromagnetic motor brakes are deactivated! When the vehicle is parked, the levers for engaging and disengaging the motors must without fail be locked firmly into the "DRIVE" position (electromagnetic motor brakes activated)!*
- 



---

**NOTE:**

The motors may only be disengaged by an attendant, not by the user!

This ensures that the motors are only disengaged if an attendant is available to secure the wheelchair and prevent unintended rolling.

---

The lever for disengaging the motors is on the rear right side on the wheelchair chassis.

**Disengaging the motors:**

- Switch off the remote.
- Withdraw the locking pin (1). Pull the engaging lever (2) backwards. The motors are disengaged.

**Engaging the motors:**

- Push the engaging lever (2) forwards. The motors are engaged.

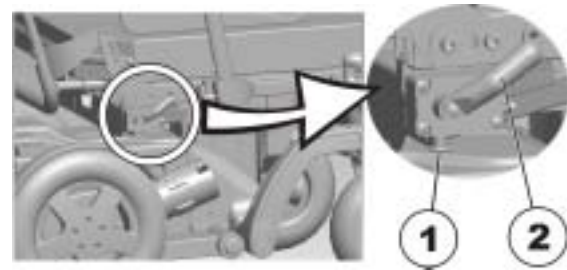

## 8 Remotes

Your wheelchair may be equipped with one of several different remotes. For information on the different functions and how to operate a particular remote, please see its corresponding User Manual (enclosed).

## 9 Adjusting the wheelchair to the user's seating posture

---



**CAUTION: Damage to wheelchair and accident hazard! It is possible that collisions can occur between wheelchair components due to various combinations of adjustment options and their individual settings!**

- *The wheelchair is fitted with an individual, multiply adjustable seating system including adjustable legrests, armrests, a headrest or other options. These adjustment options are described in the following chapters. They are used to adapt the seat to the physical requirements and the condition of the user. When adapting the seating system and the seat functions to the user, ensure that no wheelchair components collide.*
- 



### **Electrical adjustment options**

Please refer to the instruction manual for your remote for more information on operating electrical adjustment options.

---



### **Note**

Initial setup should always be done by a healthcare professional. Adjustment by the user is only recommended after they have been given appropriate guidance by the healthcare professional.

---

## 9.1 Adjustment possibility for control panel

The following information is valid for all seating systems.



---

**CAUTION:** Danger of the control panel being pushed backwards during an accidental collision with an obstacle, such as a doorframe or table, and the joystick being jammed against the armpad if the position of the control panel is adjusted and all screws are not completely tightened! This will cause the mobility device to drive forward uncontrollably and potentially injure the mobility device user and any person standing in the way!

- *When adjusting the position of the control panel, always make sure to tighten all screws securely!*
  - *If this should accidentally happen, immediately switch the mobility device electronics OFF at the control panel!*
- 

### 9.1.1 Adjust the control panel for the length of the user's arm (all seat systems)

- Loosen wing bolts (1).
- Shift the remote control forwards or backwards to the desired distance.
- Retighten the bolt.



## 9.1.2 Adjusting the height of the remote (only for foldable remote holders)



---

### Pre-requisites:

- 1x 6 mm Allen key
- 

- Unscrew screw (1) with Allen key.
- Adjust remote to required height.
- Retighten the screw.





### 9.1.3 Swivelling the remote to the side

If your wheelchair is fitted with a swing-away remote bracket, then the remote can be moved away to the side, for example to drive up close to a table.



## 9.2 Adjustment facilities for standard armrests

### 9.2.1 Changing the armrest position



---

#### Pre-requisites:

- 1x 6 mm Allen key
- 

- Loosen the screws (1) and remove them.
- Position the armrest as desired.  
If you cannot move the armrest, hit the clamping jaw slightly to loosen it.
- Reposition the screws and tighten.

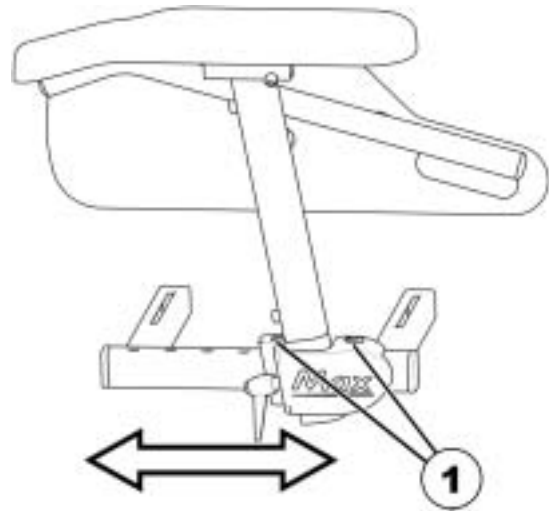

## 9.2.2 Setting the height of the armrests



---

### Requirements:

- Allen key 3 mm
- 

- Unscrew screw (1) with Allen key.
- Adjust armrest to required height.
- Retighten the screw.

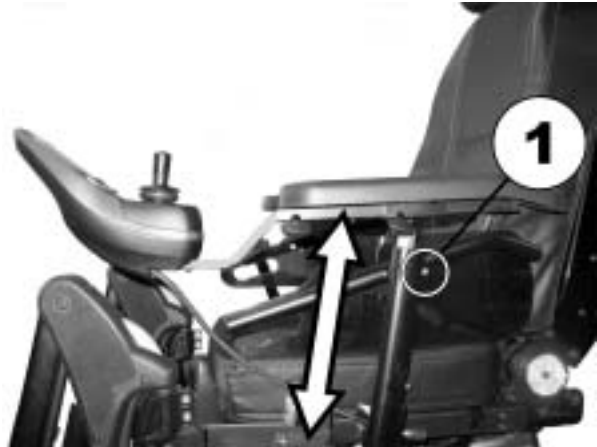

### 9.2.3 Adjusting the width of the armrests



---

**Requirements:**

- Allen key 8 mm
- 

- Loosen the screws (1).
- Adjust the armrest to the desired width.
- Retighten the screw.
- Repeat this procedure for the second armrest.

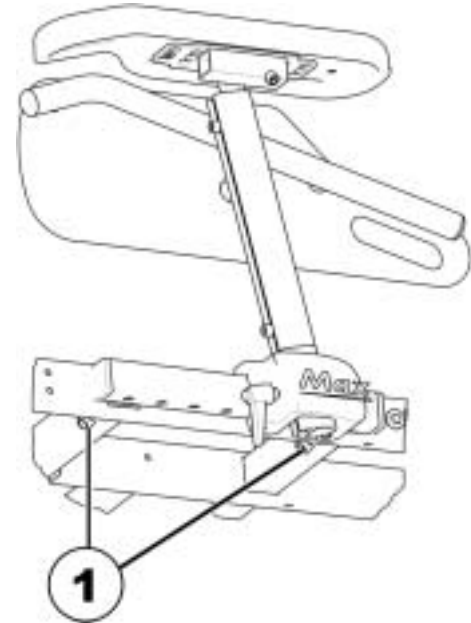

## 9.3 Adjusting the seat angle



---

**CAUTION!** Adjusting the seat tilt or the backrest angle changes the geometry of the mobility device and directly influences its tipping stability!

- *For details regarding tipping stability, negotiating gradients and obstacles and the correct adjustment of seat tilt or backrest angle, please see chapters "Taking Obstacles" on page 33 and "Driving up and down gradients" on page 35.*
- 

### 9.3.1 Electric

Please consult the user manual for your remote for information about electrical adjustment.

### 9.3.2 Manually using spindle

The seat angle is adjusted by means of a spindle, which is to be found at the front underneath the seat frame.

When adjusting the seat angle it should be ensured that at least 1cm of the threaded bolt always remains inside the spindle and is not completely unscrewed from the spindle.



---

**NOTE**

It is easier to adjust the angle of the seat when there is nobody sitting in the wheelchair.

---

The figure to the right shows the position of the spindle (1) for manual seat angle adjustment.

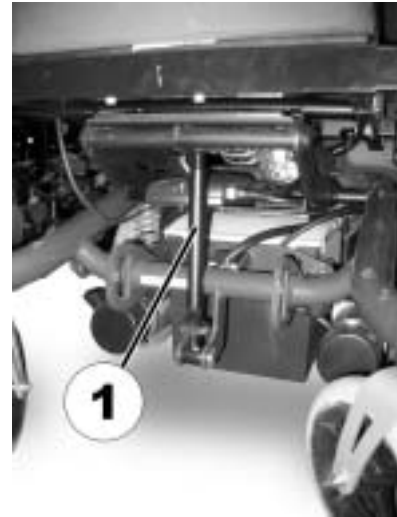

## 9.4 Adjusting the seat depth



---

**CAUTION! Risk of damage to the power wheelchair if the sideways and central seat depth adjustment is not set identically!**

- *When adjusting the seat depth, make sure to set identical values sideways and at the spindle or actuator for the backrest adjustment.*
- 



### **Note**

If necessary, you may shorten the seat depth by 130 mm using a seat depth adapter.

---



### **Pre-requisites:**

- Crosstip screwdriver
  - 6 mm Allen key
-

- Remove the seat cushion.
- Loosen the screws (1) and remove the seat plate.

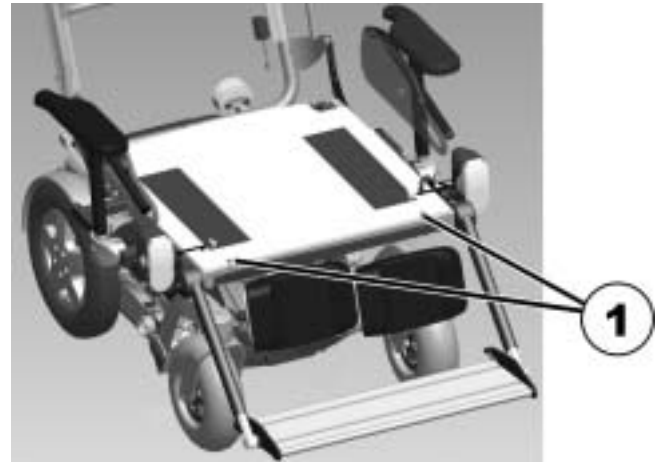

- On both sides, remove the screws, washers, and cover plates (1).
- Remove the screw (2).
- Adjust the spindle or actuator for the backrest adjustment to the desired depth. In doing so, use the labelling on the spindle or actuator as guidance.
- Retighten the screw (2).

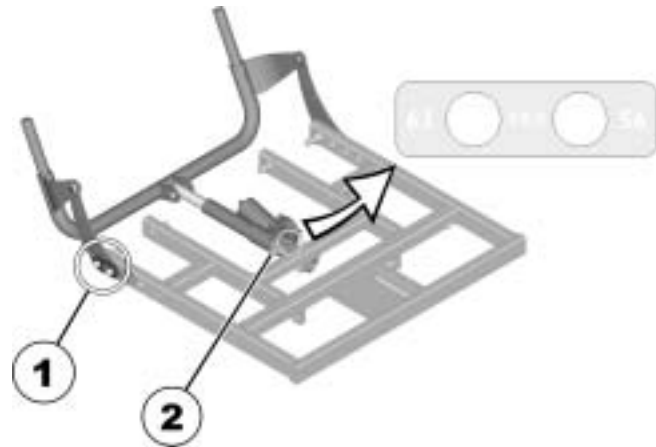



- Adjust the bearing sheets (1) to the desired depth. In doing so, use the labelling on the seat as guidance (2).
- Mount the cover plates and retighten the screws.
- Mount the seat plate and replace the seat cushion.

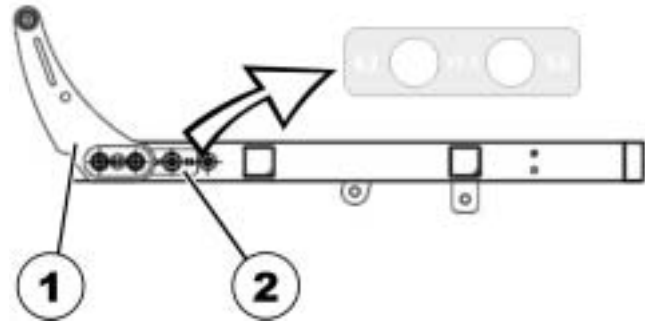

## 9.5 Adjusting the backrest

---



**CAUTION! Adjusting the seat tilt or the backrest angle changes the geometry of the mobility device and directly influences its tipping stability!**

- *For details regarding tipping stability, negotiating gradients and obstacles and the correct adjustment of seat tilt or backrest angle, please see chapters "**Taking Obstacles**" on page 33 and "**Driving up and down gradients**" on page 35.*
- 

### 9.5.1 Electric

Please consult the user manual for your remote for information about electrical adjustment.

## 9.5.2 Manual



---

### Pre-requisites:

- Crosstip screwdriver
- 

- Remove the backrest cushion and the seat cushion.
- Loosen the screws (1) and remove the seat plate.

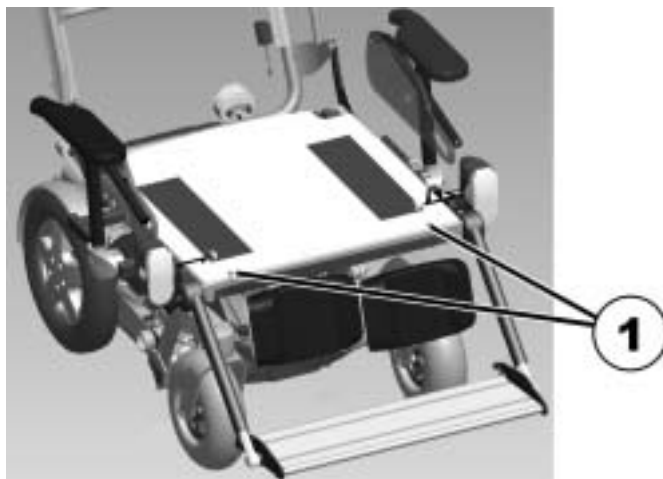

- Remove the saving and the bolt (1).
- Flip the backrest forward.
- Loosen the knurled nut (2).
- With the spindle, adjust the desired angle of the backrest.

Turning the spindle clockwise and inwards inclines the backrest backwards. Turning the spindle anti-clockwise and outwards inclines the backrest forwards.

- With the bolt, reattach the spindle to the backrest tube and secure the bolt.
- Mount the seat plate and replace the seat cushion.

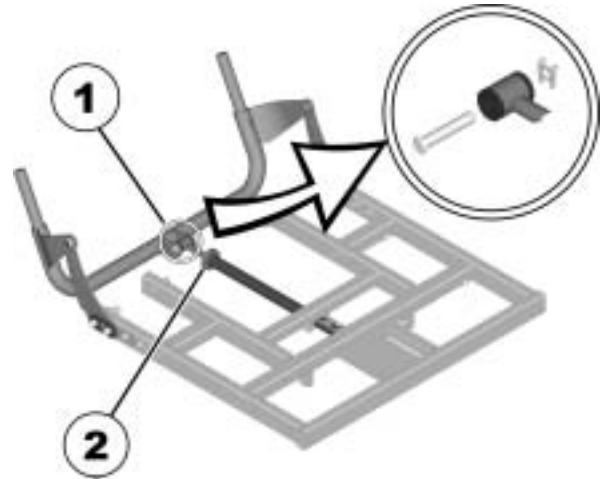

### 9.5.3 Adjusting the tension adjustable backrest upholstery

- Remove the backrest cushion (attached with Velcro strips) by pulling it up and off to access the adjustment straps.



- Adjust the tension of the individual straps as desired.
- Replace the backrest cushion.



## 9.5.4 Adjusting the backrest bend

(Storm 4 Max)

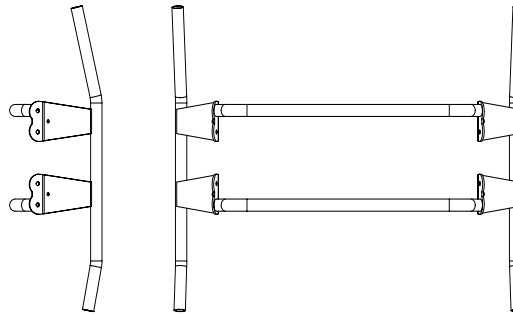

A



B



The backrest is designed with different angles as shown in picture 1. This allows for different adjustments according to how the backrest is mounted. Position A (the part of the backrest with the longer angle turned upwards) gives the user more room for the shoulder area while position B gives more room for the bottom.

- Loosen the handwheels (A) and raise the push handles as far as possible.

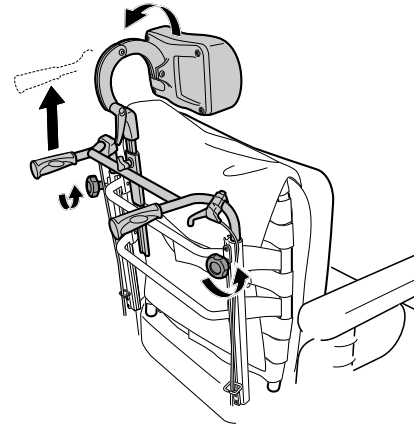

- Remove the cushion.

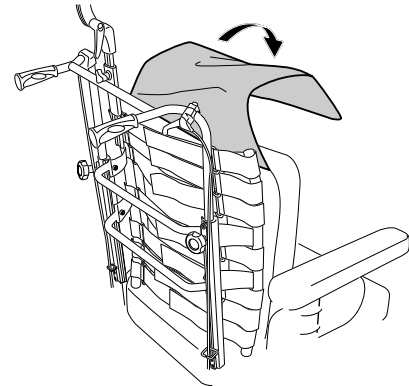

- Loosen the screws (B) and remove the backrest by lifting upwards.

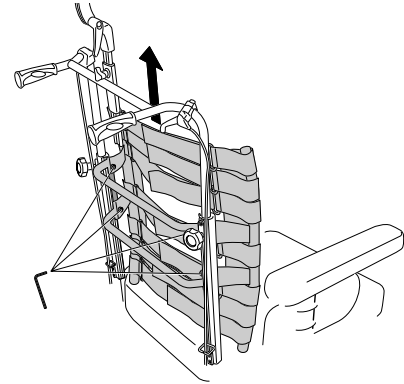

- Turn the backrest 180°.

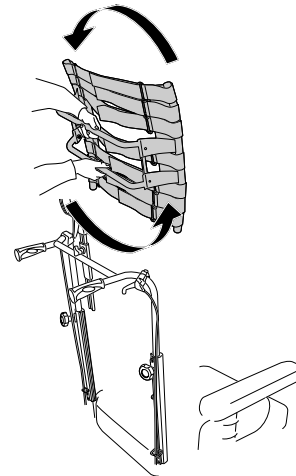



- Put the backrest back by fitting it to the receivers on the tubes. Tighten the screws.

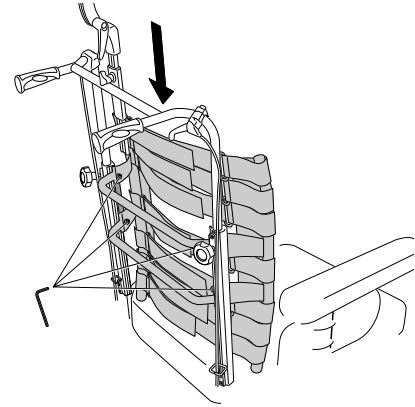

- Put the cushion and cover back. Lower the push handles and tighten the hand wheels.

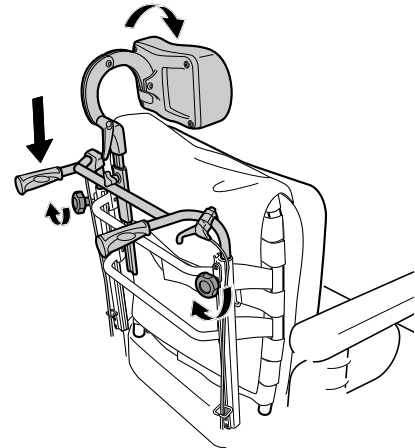
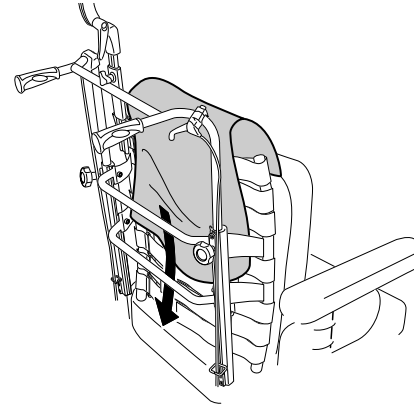

## 9.6 Adjusting the headrest

---



**CAUTION: Injury hazard during use of the mobility aid as a vehicle seat if a headrest is wrongly adjusted or not installed! This can cause the neck to be hyperextended during collisions!**

- *A headrest must be installed! The headrest optionally supplied for this mobility device by Invacare® is perfectly suitable for use during transport.*
- *The headrest must be adjusted to the user's ear height.*



## 9.6.1 Adjusting the position of the headrest or neckrest

The adjustment of the position is the same for all headrests and neckrests.



---

### Pre-requisites:

- Allen key 5 mm
- 

- Loosen the screws (1, 2) or the clamping lever (3).
- Adjust the headrest or neckrest to the required position.
- Retighten screws and clamping lever.
- Loosen the Allen screw (4).
- Slide the headrest left or right to the required position.
- Retighten the Allen screw.

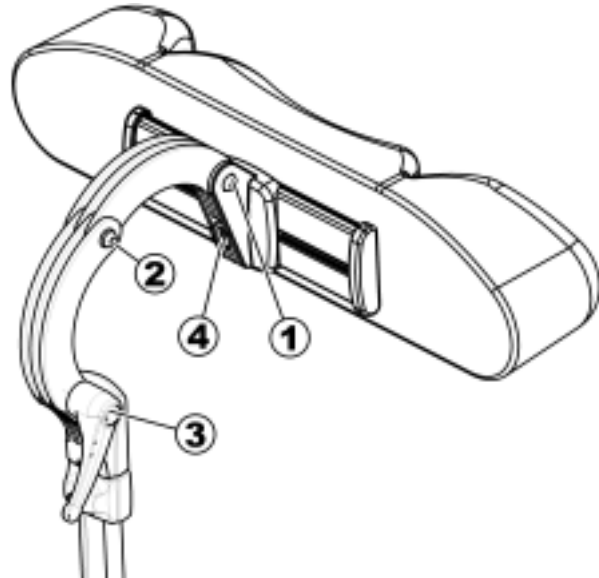

## 9.6.2 Adjusting the height of the headrest or neckrest

The adjustment of the height is the same for all headrests and neckrests.

- Loosen the thumb screw (1).
- Adjust the headrest or neckrest to the required height.
- Retighten thumb screw.



### 9.6.3 Adjusting the cheek supports

- Push the cheek supports inward or pull them out to the required position.



## 9.7 Postural belts

A postural belt is an option which can either be fixed to the wheelchair ex-works or can be retrofitted by your specialist dealer. If your wheelchair is fitted with a postural belt, your specialist dealer will have informed you about fitting and usage.

The postural belt is used to help the wheelchair user keep an optimum sitting position. Correct use of the belt assists the user in sitting securely, comfortably and well-positioned in the wheelchair, especially for such users who do not have such a good sense of balance while sitting.



---

**NOTE:**

We recommend using the postural belt whenever the wheelchair is used. The belt should be tight enough to ensure that you are sitting comfortably and that your body is in the correct sitting position.

---

## 9.7.1 Types of postural belts

Your wheelchair can be fitted with the following postural belt types ex-works. If your wheelchair has been fitted with a different belt to those listed below, please ensure that you have received the manufacturer's documentation with regard to correct fitting and use.

### **Belt with metal buckle, adjustable one side**

Belt can only be adjusted on one side which can result in the buckle not sitting centrally.



### **Belt with metal buckle, adjustable both sides**

Belt can be adjusted on both sides. This means that the buckle can be centrally positioned.



## 9.7.2 Adjusting the postural belt correctly

- Ensure that you are sitting correctly, which means that you are sitting right at the back of the seat, your pelvis is positioned erect and as symmetrically as possible, not to the front, to the side or at one edge of the seat.
- Position the postural belt so that your hipbones can be easily felt above the belt.
- Adjust the belt length using one of the adjustment aids described above. The belt should be adjusted so that you can fit a flat hand between the belt and your body.
- The buckle should be positioned as centrally as possible. In doing so, please carry out adjustments on both sides as much as possible.

- Please check your belt every week to ensure that it is still in good working condition; to ensure it has no damage or wear, and that it is fixed properly to the wheelchair. If the belt is only fastened with a bolted connection, ensure that the connection has not loosened or undone. You can find more information about maintenance work on belts in the service manual, which is available from Invacare®.



## 9.8 Adjusting or removing the luggage carrier



---

**CAUTION! Risk of damage as a result of collisions! Parts of the electric wheelchair may be damaged if the luggage carrier collides with the seat during seat angle or backrest adjustment.**

- *Ensure that the luggage carrier is out of the range of both seat angle and backrest adjustment.*
- 



---

**CAUTION! Risk of breakage due to excessive load! The luggage carrier can break if too great a load is applied.**

- *The maximum permitted load on the luggage carrier is 10 kg.*
- 

- Open the clamp levers (1) of the luggage carrier bracket.
- Slide the luggage carrier forward or backward or remove it.
- Close the clamp levers of the luggage carrier bracket.

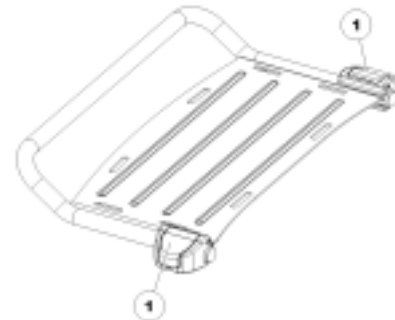

## 9.9 Using the KLICKfix adapter

Your wheelchair can be fitted with the mini-adapter from the Rixen + Kaul KLICKfix system. To this you can attach various accessories such as the cellphone case supplied by Invacare, which you can use to transport your cellphone, sports glasses etc.



---

**CAUTION! Risk posed by unsecured accessories! Accessories can fall off and get lost if they are not properly secured.**

- *Check that the accessory is correctly locked in and seated securely every time you use the wheelchair.*
- 



---

**CAUTION! Risk of breakage due to excessive load! The KLICKfix adapter can break if too great a load is applied.**

- *The maximum permitted load on the KLICKfix adapter is 1 kg.*
- 

### **Securing the accessory:**

- Push the accessory into the KLICKfix adapter.

The accessory locks in securely.

### **Removing the accessory:**

- Press the red button and remove the accessory.

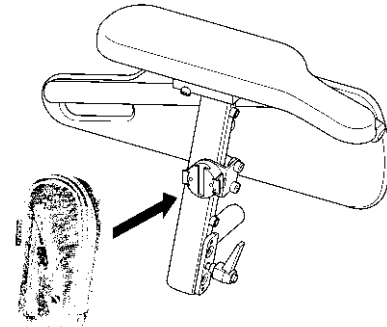

The adapter can turn in 90° steps, allowing you to attach an accessory from any of four different directions. Please refer to the installation instructions which are available from your Invacare® dealer or directly from Invacare®.

More information on the KCLICKfix system is available at <http://www.klickfix.com>.

## 9.10 Legrests

### 9.10.1 General adjustments

#### 9.10.1.1 Adjusting the length of the legrest



---

**PLEASE NOTE: Danger of injury due to incorrect adjustment of the footrests and legrests.**

- *Before and during every journey it is imperative to ensure that the legrests contact neither the castor wheels nor the ground!*
- 



---

**Pre-requisites:**

- 1x 5 mm Allen key
-

- Loosen the screws (1) with the Allen key.
- Adjust to the desired length.  
Take care to adjust both sides simultaneously to prevent the legrests from getting jammed.
- Retighten the screws.



### 9.10.1.2 Adjusting the height of the calf pad



---

**Pre-requisites:**

- Crosstip screwdriver
- 
- Remove the cushion of the calf pad.



- Loosen the screws (1) using the crosstip screwdriver and remove them.

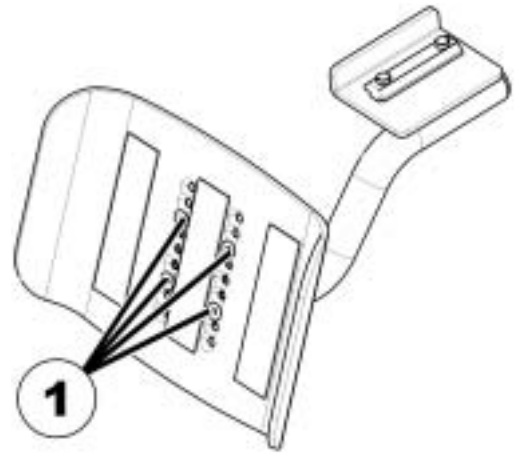

- Move the calf pad to the desired position.
- Re-insert the screws and tighten.

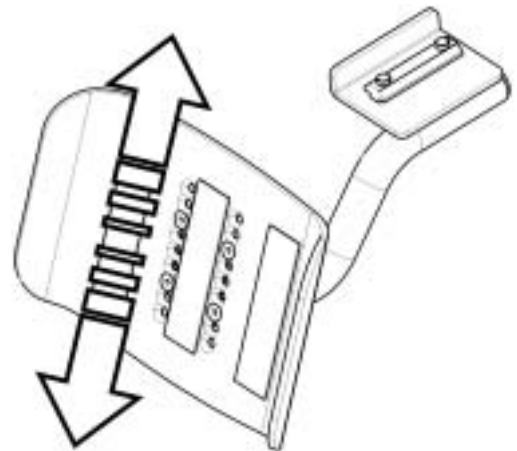

### 9.10.1.3 Adjusting the calf pad width



---

**Pre-requisites:**

- 4 mm Allen key
- 

- Loosen the Allen screws (1) using the Allen key.
- Set the calf pad to the desired position.
- Re-tighten the screws.



## 9.10.2 Vari-F footrest

### 9.10.2.1 Swivelling the footrest outward and/or removing

The small unlocking button is located on the upper section of the footrest. When the footrest is unlocked, it can be swivelled inward or outward when getting into the wheelchair as well as being removed completely.

- Press the unlocking button (1) and swivel the footrest outward.
- Remove the footrest in an upward direction.





### 9.10.2.2 Setting the angle



---

**PLEASE NOTE: Danger of injury due to incorrect adjustment of the footrests and legrests.**

- *Before and during every journey it is imperative to ensure that the legrests contact neither the castor wheels nor the ground!*
- 



**Pre-requisites:**

- 1x 6 mm Allen key
- 

- Loosen the screw (1) using the Allen key.
- If the footrest cannot be moved after loosening the screw, position a metal pin in the designated borehole (2) and use a hammer to knock on this lightly. The clamping mechanism in the interior of the footrest will be released by this. Repeat the procedure from the other side of the footrest if necessary.



- Loosen the screw (1) using the Allen key.
- Set the desired angle.
- Re-tighten the screw.



### 9.10.2.3 Setting the end stop of the footrest



---

**Pre-requisites:**

- 1x 6 mm Allen key
  - 1x 10 mm open-ended spanner
- 

The end position of the footrest is determined by means of a rubber stop (1).



The rubber stop can be screwed in or out (A) or pushed up or down (B).



- Use the Allen key to loosen the screw (1) and swivel the footrest upward in order to access the rubber stop.



- Use the open-ended spanner to loosen the counternut (1).



- Move the rubber stop to the desired position
- Re-tighten the counternut



- Move the footrest to the desired position.
- Re-tighten the screw.



# 10 Electrical system

## 10.1 Electronics protection system

The vehicle drive electronics is fitted with an overload protection.

If the drive is severely overloaded over a long period (e.g. during steep climbs) and, above all, at simultaneous high external temperatures, the electronic system can overheat. In this case, the vehicle performance is gradually reduced until it comes to a standstill. The status display shows a corresponding blink code (please refer to the user manual for your remote). If you switch the drive electronics off and then on again, the error message is deleted and the electronics can be switched on again. It can however take up to five minutes until the electronics has cooled down enough for the drives to apply their full performance.

If the drive is blocked due to an insurmountable obstacle, for example a kerb or similar which is too high, and the driver attempts to run the drive for more than 20 seconds against this obstacle, the electronic system switches the drives off to avoid damage. The status display shows a corresponding flash code (please refer to the user manual for your remote). If you switch the drive electronics off and then on again, the error message is deleted and the electronics can be switched on again.



---

### NOTE

A defective main fuse may be replaced only after checking the entire electric system. An Invacare® specialised dealer must perform the replacement. You can find information on the fuse type in chapter "**Technical specifications**" starting on page **115**.

---

## **10.2 Batteries**

Power is supplied by two 12 V batteries. The batteries are maintenance-free and only need regular charging.

In the following, you find information on how to charge, handle, transport, store, maintain, and use batteries.

### **10.2.1 Charging the batteries**

#### **10.2.1.1 General information on charging**

New batteries should always be fully charged once before their first use. New batteries will be at their full capacity after having run through approx. 10 - 20 charging cycles (break-in period). This break-in period is necessary to fully activate the battery for maximum performance and longevity. Thus, range and running time of your mobility device could initially increase with use.

Gel/AGM lead acid batteries do not have a memory effect as NiCd batteries.

#### **10.2.1.2 General instructions on charging**

Follow the instructions listed below to ensure safe use and longevity of the batteries:

- Charge 12 hours prior to initial usage.
- We recommend charging the batteries daily after every discharge even after partly discharge, as well as each night over night. Depending on the level of discharge, it can take up to 12 hours until the batteries are fully charged again.
- When the battery indicator reached the red LED range, charge the batteries for 16 hours minimum, neglecting the charge complete display!
- Try to provide a 24 hour charge once a week to make sure that both batteries are fully charged.

- Do not cycle your batteries at a low state of charge without regularly recharging them fully.
- Do not charge your batteries under extreme temperatures. High temperatures above 30 °C are not recommended for charging as well as low temperatures below 10 °C.
- Use only charging devices in Class 2. This class of chargers may be left unattended during charging. All charging devices which are supplied by Invacare® comply with these requirements.
- You cannot overcharge the batteries when using the charger supplied with your vehicle, or a charger that has been approved by Invacare®.
- Protect your charger from sources of heat such as heaters and direct sunlight. If the battery charger overheats, charging current will be reduced and the charging process delayed.

### **10.2.1.3 How to charge the batteries**

Please see the instruction manuals for your remote and battery charger for the position of the charging socket and further information about charging the batteries.





---

**WARNING!****Risk of explosion and destruction of batteries if the wrong battery charger is used!**

- *Only ever use the battery charger supplied with your vehicle, or a charger that has been approved by Invacare®.*

**Risk of electric shock and damage to the battery charger if it gets wet!**

- *Protect the battery charger from water.*
- *Always charge in a dry environment.*

**Risk of short circuit and electric shock if the battery charger has been damaged!**

- *Do not use the battery charger if it has been dropped or damaged.*

**Risk of electric shock and damage to the batteries!**

- *NEVER attempt to recharge the batteries by attaching cables directly to the battery terminals.*

**Risk of fire and electric shock if a damaged extension cable is used!**

- *Only ever use an extension cable if it is absolutely necessary. In case you must use one, make sure it is in good condition.*

**Risk of injury if using the wheelchair during charging!**

- *DO NOT attempt to recharge the batteries and operate the wheelchair at the same time.*
  - *DO NOT sit in the wheelchair while charging the batteries.*
- 

- Switch off the mobility device.
- Connect the battery charger to the charger socket.
- Connect the battery charger to the power supply.

**10.2.1.4 How to disconnect the batteries after charging**

- Once charging is complete, first disconnect the battery charger from the power supply, then disconnect the plug from the remote.

## 10.2.2 Storage and Maintenance

Follow the instructions listed below to ensure safe use and longevity of the batteries:

- Always store the batteries fully charged.
- Do not leave the batteries in a low state of charge for an extended length of time. Charge a discharged battery as soon as possible.
- In case your mobility device is not used for a longer period of time (that is more than two weeks), the batteries must be charged at least once a month to maintain a full charge and always be charged before use.
- Avoid hot and cold extremes when storing. We recommend to store batteries at a temperature of 15 °C.
- Gel and AGM batteries are maintenance-free. Any performance issues should be handled by a properly trained mobility device technician.

## 10.2.3 Instructions on using the batteries



---

### **CAUTION! Risk of damaging the batteries.**

- *Avoid ultra-deep discharges and never drain your batteries completely.*
- 

- Pay attention to the Battery Charge Indicator! Charge the batteries when the Battery Charge Indicator shows that battery charge is low.

How fast the batteries discharge depends on many circumstances, such as ambient temperature, condition of the surface of the road, tyre pressure, weight of the driver, way of driving and utilisation of lighting.

- Try to charge the batteries always before you reach the red LED range.

The last 3 LED (two red and one orange) mean a remaining capacity of about 15 %.

- Driving with blinking red LED's means an extreme stress for the battery and should be avoided under normal circumstances.
- When only one red LED is blinking, the Battery Safe feature is enabled. From this time, speed and acceleration is reduced drastically. It will allow you to move the mobility device slowly out of a dangerous situation before the electronic finally cuts off. This is deep discharging and should be avoided.
- Be aware that for temperatures below 20 °C, the nominal battery capacity starts to decline. For example, at -10 °C the capacity is reduced to about 50 % of the nominal battery capacity.
- To avoid damaging the batteries, never allow them to be fully discharged. Do not drive on heavily discharged batteries if it is not absolutely necessary, as this will strain the batteries unduly and shorten their life expectancy.
- The earlier you recharge the batteries, the longer they live.
- The depth of discharge affects the cycle life. The harder a battery has to work, the shorter is its life expectancy.

Examples:

- One deep discharge stresses the same as 6 normal cycles (green /orange display off).
- The battery life is about 300 cycles at 80% discharge (first 7 LED off), or about 3000 cycles at 10% discharge (one LED off).



---

**NOTE:**

The number of LED can vary depending on the remote type.

---

- Under normal operation, once a month the battery should be discharged until all green and orange LED are off. This should be done within one day. A 16 hour charge afterwards is necessary as reconditioning.

## **10.2.4 Transporting batteries**

The batteries supplied with your electric vehicle are not hazardous goods. This classification is based on the German GGVS Hazardous Goods Road Transport Ordinances, and the IATA/DGR Hazardous Goods Rail Transport / Air Transport Ordinances. Batteries may be transported without restrictions, whether by road, rail or by air. Individual transport companies have, however, guidelines which can possibly restrict or forbid certain transport procedures. Please ask the transport company regarding each individual case.

## **10.2.5 Handling batteries**

### **10.2.5.1 General instructions on handling the batteries**

- Never mix and match different battery manufactures or technologies, or use batteries that do not have similar date codes.
- Never mix gel with AGM batteries.
- Always have your batteries installed by a properly trained mobility device technician. They have the necessary training and tools to do the job safely and correctly.

### **10.2.5.2 How to handle damaged batteries correctly**



---

**WARNING:****Corrosion and burns from acid leakage if batteries are damaged!**

- *Remove clothes that have been soiled by acid immediately.*

**After contact with skin:**

- *Immediately wash affected area with lots of water.*

**After contact with eyes:**

- *Immediately rinse eyes under running water for several minutes; consult a physician.*
- 

- Always wear safety goggles and appropriate safety clothing when handling damaged batteries.
- Place damaged batteries in an acid-resistant receptacle immediately after removing them.
- Only ever transport damaged batteries in an appropriate acid-resistant receptacle.
- Wash all objects that have come into contact with acid with lots of water.

**Disposing of dead or damaged batteries correctly**

Dead or damaged batteries can be given back to your dealer or directly to Invacare®.

# 11 Maintenance

The term „Maintenance“ means any task performed to ensure that a medical device is in good working order and ready for use as intended. Maintenance encompasses different areas, such as everyday care and cleaning, inspection checks, repair tasks and refurbishment.



---

**NOTE:**

Have your vehicle checked once a year by an authorised Invacare® dealer in order to maintain it's driving safety and roadworthiness.

---

## 11.1 Cleaning the mobility device

When cleaning the mobility device, pay attention to the following points:

- Only use a damp cloth and gentle detergent.
- Do not use any abrasive or scouring agents.
- Do not subject the electronic components to any direct contact with water.
- Do not use any high-pressure cleaning devices.

### **Disinfection**

Spray or wipe disinfection using a tested and recognised product is permitted. A list of the current permitted disinfectants is available from the Robert Koch Institute at <http://www.rki.de>.

## 11.2 Inspection checks

The following tables list inspections that need to be carried out at the appropriate intervals. If the mobility device should not pass one of these inspections, please read the appropriate chapter and follow the instructions contained there, or contact an authorised Invacare® dealer. Please refer to the service manual for this mobility device for an extensive list of inspections and instructions for upkeep. You can order a service manual from Invacare®. This does, however, contain instructions for specially trained service technicians and describes working operations which are not intended to be carried out by the user.

### 11.2.1 Before each use of the mobility device

Component	Inspection	If inspection is not passed
<b>Horn</b>	<ul style="list-style-type: none"><li>• Check of correct mode of operation.</li></ul>	<ul style="list-style-type: none"><li>• Notify dealer</li></ul>
<b>Lighting unit</b>	<ul style="list-style-type: none"><li>• Check of correct operating mode for all lights such as indicators, headlights and rear lights.</li></ul>	<ul style="list-style-type: none"><li>• Notify dealer</li></ul>
<b>Batteries</b>	<ul style="list-style-type: none"><li>• Check of battery charging status. Please refer to the remote manual for information about battery charging status display.</li></ul>	<ul style="list-style-type: none"><li>• Charge the batteries (see chapter <b>"Charging the batteries"</b> on page 79).</li></ul>



## 11.2.2 Weekly

Component	Inspection	If inspection is not passed
<b>Armrests /side panels</b>	<ul style="list-style-type: none"> <li>• Check to ensure that the armrests can be correctly inserted in the holders and do not wobble.</li> </ul>	<ul style="list-style-type: none"> <li>• Tighten the screw or camping lever to fix the armrests (see chapter "<b>Adjustment possibility for control panel</b>" on page 39).</li> <li>• Notify dealer</li> </ul>
<b>Tyres (pneumatic)</b>	<ul style="list-style-type: none"> <li>• Check the correct tyre condition.</li> </ul>	<ul style="list-style-type: none"> <li>• Notify dealer</li> </ul>
	<ul style="list-style-type: none"> <li>• Check the correct tyre pressure.</li> </ul>	<ul style="list-style-type: none"> <li>• Inflate the tyres to the correct pressure(see chapter "<b>Technical specifications</b>" on page 115).</li> <li>• Repair the inner tube if the tyres are flat (see chapter "<b>Repair Instructions</b>" on page 91) or notify your dealer for repair.</li> </ul>
<b>Tyres (puncture-proof)</b>	<ul style="list-style-type: none"> <li>• Check the correct tyre condition.</li> </ul>	<ul style="list-style-type: none"> <li>• Notify dealer</li> </ul>

### 11.2.3 Monthly

Item	Inspection check	Action
<b>All upholstered parts</b>	<ul style="list-style-type: none"> <li>• Check for damage and wear.</li> </ul>	<ul style="list-style-type: none"> <li>• Contact your dealer.</li> </ul>
<b>Removable legrests</b>	<ul style="list-style-type: none"> <li>• Check whether the legrests can be fixed securely and whether the loosening mechanism is properly operable (see chapter "<b>Legrests</b>" on page 67).</li> </ul>	<ul style="list-style-type: none"> <li>• Contact your dealer.</li> </ul>
	<ul style="list-style-type: none"> <li>• Check that all adjustment options function properly (see chapter "<b>Legrests</b>" on page 67).</li> </ul>	<ul style="list-style-type: none"> <li>• Contact your dealer.</li> </ul>
<b>Castors</b>	<ul style="list-style-type: none"> <li>• Check that castors rotate and swivel freely.</li> </ul>	<ul style="list-style-type: none"> <li>• Contact your dealer.</li> </ul>
<b>Drive wheels</b>	<ul style="list-style-type: none"> <li>• Check that the drive wheels rotate without wobbling. It is easiest to have someone stand behind the mobility device and observe the drive wheels as you drive away from them to do this.</li> </ul>	<ul style="list-style-type: none"> <li>• Contact your dealer.</li> </ul>
<b>Electronics and connectors</b>	<ul style="list-style-type: none"> <li>• Check all cables for damage and all connecting plugs for snug fit.</li> </ul>	<ul style="list-style-type: none"> <li>• Contact your dealer.</li> </ul>

## 11.3 Repair Instructions

---



### **Important information about maintenance work tools!**

Some maintenance work which is described in this manual and can be carried out by the user without problems require the correct tools for proper work. If you do not have the correct tool available we do not recommend that you try to carry out the relevant work. In this case, we urgently recommend that you contact an authorised specialist workshop.

---

The following are instructions on maintenance and repairs that can be performed by the user. For the specifications of spare parts please see "**Technical specifications**" on page **115**, or consult the Service Manual, available from Invacare® (in this connection please see the addresses and phone numbers in section "**How can you get in touch with Invacare®?**" on page **3**). In case you require assistance, please contact your Invacare® Dealer.

### 11.3.1 Repairing a flat tyre

---



**WARNING: Danger of damage or injury if the vehicle is accidentally set into motion during repairs!**

- *Switch the power off (ON/OFF Button)!*
  - *Engage the motors!*
  - *Secure the vehicle against rolling away by placing wedges under the wheels!*
-

## 11.3.2 Repairing a flat tyre at the front (tyre type 3.00x4")

(Storm 4 Max)



### Requirements:

- Allen key 5 mm
- Open-end spanner 17 mm
- Repair kit for inner tubes **or** an new inner tube.
- Talcum powder

### Remove the front wheel

- Jack the vehicle up and place a block of wood underneath it to prop it up.
- Use the Allen key to remove the fillister head screws (1, inner and outer), using the open-end spanner at the same time to immobilise the axle counter nut (2, on the inside, between fork and wheel).
- Remove the axle and the wheel from the fork.



### NOTE

Re-assembly is done in reverse order. Make sure that the wheel is put back on the same side it was on, and that it runs in the same direction it did before it was removed.

### Repair the flat tyre.

- Remove the valve cap.
- Let the air out of the tyre by pressing the pin in the centre of the valve in.
- Remove the 5 Allen screws (3)
- Take the tyre and the inner tube off of the rim halves.
- Repair the inner tube and re-fit, or replace it with a new one.

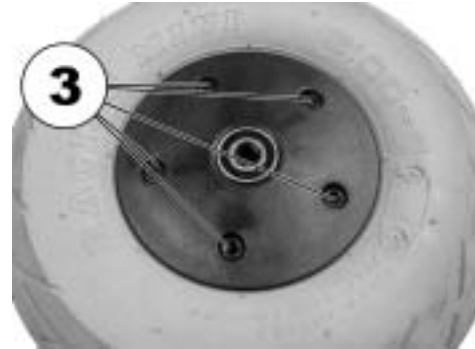

---

#### NOTE

In case the old inner tube is to be repaired and used again, and it happens to get wet during repair, then it is easier to re-fit it if you powder it lightly with talcum powder.

---

- Place the rim halves in the tyre from the outside.
- Pump up the tyre a little.
- Re-position the Allen screws in the rim and tighten them firmly.
- Check to make sure that the tyre is squarely in place on the rim.
- Pump up the tyre to the recommended tyre pressure.
- Check to make sure that the tyre is still squarely and snugly in place on the rim.
- Screw the valve cap back on.
- Refit the wheel.

### 11.3.3 Repairing tyre punctures (drive wheel)



---

**Injury hazard! If the wheel has been insufficiently tightened during assembly, it can become loosened during driving!**

- *When reassembling the drive wheels, tighten the Allen screws at a torque of 30 Nm!*
  - *Secure all screws using a suitable blocker (e.g. Loctite 243)!*
- 



#### **Requirements:**

- Allen key – open-ended spanner 6 mm
  - Torque wrench
  - Repair kit for tyre repair **or** a new inner tube
  - Talcum powder
  - Screw blocker Loctite (e.g. Loctite 243)
- 

#### **Removing the wheel**

- Block up the vehicle (place wooden blocks under frame).
- Unscrew the screw (1).
- Remove the wheel from the hub.





---

**NOTE**

Re-assembly is done in reverse order. Ensure that the tyre is replaced on the same side and in the same travel direction as it was previously mounted.

---

**Repairing the flat tyre**

---

**EXPLOSION HAZARD!**

**The wheel will explode if you do not let the air out of the tyre before removing the wheel!**

- *Always let the air out of the tyre before removing it (press in the pin in the middle of the valve)!*
- 

- Unscrew valve cap.
- Depressurise tyre completely by pressing in the pin in the valve .
- Remove the 5 cylinder head screws (back of the wheel, 2).
- Remove the rim halves from the tyre.
- Remove the inner tube from the tyre.
- Repair inner tube and replace, or insert new.

**NOTE**

If the old inner tube is to be repaired and re-used, and has become wet during repair, you can make replacement easier by sprinkling the inner tube with a little talcum powder.

---

- Insert the wheel rim halves from outside into the tyre.
- Pump a little air into the inner tube.
- Reinsert the cylinder head screws and tighten to 10 Nm. Avoid crushing the inner tube!
- Ensure that the tyre outer is seated correctly.
- Pump the tyre up to the prescribed pressure.
- Ensure that the tyre outer is seated correctly again.
- Screw the valve cap back on.
- Refit the wheel.



## 12 Transport



**CAUTION:** Injury hazard or material damage if a power wheelchair which is fitted with a table is transported in a vehicle!

- *If a table is fitted, always remove it before transporting the wheelchair.*



### 12.1 Transferring the wheelchair to a vehicle



**WARNING:** The wheelchair is in danger of tipping over if it is transferred to a vehicle while the driver is still seated in the wheelchair!

- *Transfer the wheelchair without the driver whenever possible!*
- *If the wheelchair with the driver has to be transferred to a vehicle using a ramp, ensure that the ramp does not exceed the maximum safe slope (see chapter "**Technical specifications**" starting on page **115**)!*
- *If the wheelchair has to be transferred to a vehicle using a ramp that does exceed the maximum safe slope (see chapter "**Technical specifications**" starting on page **115**), a winch must then be used! An attendant can then safely monitor and assist the transfer process!*
- *Alternatively, a platform lift may be used!*
- *Ensure that the total weight of the power wheelchair including the user does not exceed the maximum permitted total weight for the ramp or platform lift!*
- *The wheelchair should always be transferred to a vehicle with the backrest in an upright position, the seat lifter lowered and the seat tilt in the upright position (see chapter "**Driving up and down gradients**" on page **35**)!*

- Drive or push your wheelchair into the transport vehicle using a suitable ramp.

## 12.2 Use of the wheelchair as a seat in a vehicle

---



### Note

The following section does not apply to models or configurations which may not be used as a vehicle seat. These are identified by the following labels on the lashing eyes:



**WARNING: Danger of death or serious injury to the wheelchair user and potentially any other nearby occupant of the vehicle, if a wheelchair is secured using a 4-point tie-down system available from a third party supplier and the unladen weight of the wheelchair exceeds the maximum weight for which the system is certified!**

- *The actual weight of this wheelchair can exceed 140 kg! A suitably strong and proven 4-point tie-down system is available from Unwin Safety Systems! Please contact Unwin for more information on how to obtain such a system in your country!*

*Unwin Safety Systems*

*Phone: + 44 (0)1935 827740*

*Email: sales@unwin-safety.co.uk*

*Web: www.unwin-safety.com*

- *An alternative way to safely use this wheelchair as a vehicle seat may be by using the Docking Station system if the wheelchair is compatible with that system, available separately! Please contact Invacare if you require the details.*
-



---

**WARNING: Danger of injury or damage to the wheelchair or to the transporting vehicle, if the legrests are in a raised position while the wheelchair is used as a vehicle seat!**

- *Always completely lower height-adjustable legrests, if fitted.*
- 



---

**Caution: There is a danger of injury if the wheelchair is not properly secured during use as a vehicle seat!**

- *If possible, the user should always leave the wheelchair to use a vehicle seat and the safety belts provided with the vehicle.*
  - *The wheelchair should always be anchored facing in the transport vehicle's intended direction of travel.*
  - *The wheelchair must always be secured in accordance with the wheelchair and anchoring system manufacturers' operating manual.*
  - *Always remove and secure any accessory parts fixed to the wheelchair such as chin controls or tables.*
  - *If your wheelchair is equipped with an angle adjustable backrest, then it must be placed in an upright position.*
  - *Fully lower elevated legrests, if fitted.*
  - *Fully lower the seat lifter, if fitted.*
- 



---

**WARNING: Danger of injury exists if a power wheelchair that is not equipped with leak-proof batteries is transported in a vehicle!**

- *Only ever use leak-proof batteries!*
-



---

**Please note**

In order to use a wheelchair as a motor vehicle seat, it needs to be equipped with attachment points to enable anchoring in the motor vehicle. These accessories may be included in the standard scope of wheelchair order and delivery in some countries (UK for example), but may also be obtained from Invacare® as an option in other countries.

---

This mobility device complies with the requirements of ISO 7176-19:2001 and may be used as a vehicle seat in connection with an anchoring system that has been checked and approved in accordance with ISO 10542. The transporting vehicle must be professionally converted to anchor the mobility device. Contact your vehicle's manufacturer for more information.

The mobility device has undergone a crash test in which it was anchored in the transporting vehicle's direction of travel. Other configurations were not tested. The crash test dummy was secured using pelvic and upper body safety belts. Both types of safety belt should be used in order to minimise the risk of injuries to head or upper body.

---

**Invacare tests with a 4-point tie-down system from Unwin Safety Systems.**

Contact Unwin for more information on how to obtain such a system for your country and vehicle type. For information concerning the curb weight, refer to **Technical specifications** starting on page **115**.

---

It is imperative that the mobility device is inspected by an authorised dealer before being used again after being involved in a crash. Alterations to the wheelchair anchoring points may not be carried out without the manufacturer's permission.

## 12.2.1 How the wheelchair is anchored in a vehicle for use as a vehicle seat

The power wheelchair is fitted with four anchoring points, which are labelled with the symbol shown on the right. Snap hooks or belt loops can be used for fixation.



- Secure the wheelchair at the front (1) and at the rear (2) with the anchoring system belts.
- Secure the wheelchair by tensioning the belts in accordance with the manufacturer's anchoring system operating manual.



## 12.2.2 How the user is secured within the wheelchair

---



**CAUTION: There is a danger of injury if the user is not properly secured within the wheelchair!**

- *Even if the wheelchair is fitted with a postural belt, this is no substitute for a proper safety belt which complies with ISO 10542 in the transport vehicle. Always use the safety belt installed in the transport vehicle.*
  - *Safety belts must be in contact with the user's body. They must not be held at a distance from the user's body using parts of the wheelchair such as armrests or wheels. Refer to the illustration on page 104.*
  - *Safety belts must be pulled as tightly as possible without causing the user discomfort. Refer to the illustration on page 104.*
  - *Safety belts must not be positioned while twisted.*
  - *Ensure that the third seatbelt anchorage point is not fixed directly to the vehicle floor, but to one of the vehicle uprights.*
-



---

**CAUTION: Injury hazard during use of the mobility aid as a vehicle seat if a headrest is wrongly adjusted or not installed! This can cause the neck to be hyperextended during collisions!**

- *A headrest must be installed! The headrest optionally supplied for this mobility device by Invacare® is perfectly suitable for use during transport.*
- *The headrest must be adjusted to the user's ear height.*





Seat belts may not be held at a distance from the user's body using parts of the wheelchair such as armrests or wheels.

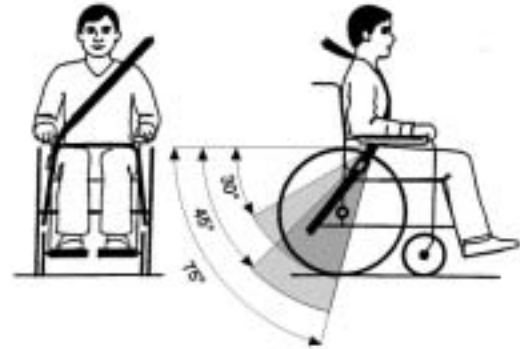

The pelvic belt should be positioned in the area between the user's pelvis and thighs so that it is unobstructed and not too loose. The ideal angle of the pelvic belt to the horizontal is between 45° and 75°. The maximum permissible angle is between 30° and 75°. The angle should never be less than 30°!



The safety belt installed in the transporting vehicle should be applied as shown in the illustration at right.

- 1) Centre line of the body
- 2) Centre of the sternum

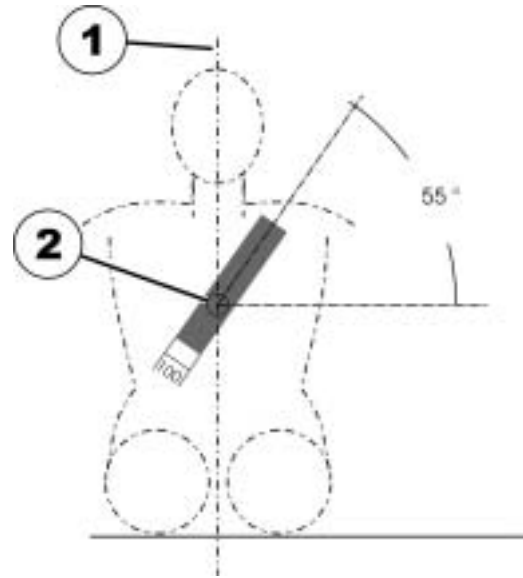

## 12.3 Securing the wheelchair for transport without passengers



---

**CAUTION: Injury hazard!**

- *If you are unable to fasten your electric wheelchair securely in a transport vehicle, Invacare® recommends that you do not transport it!*
- 

- Before transporting your wheelchair, make sure the motors are engaged and that the Joystick Box is switched off.

Invacare® strongly recommends that you additionally disconnect or remove the batteries. See "Removing/Installing the batteries" on page 112.

- Invacare® strongly recommends securing the wheelchair to the floor of the transporting vehicle.

### 12.3.1 Opening the rear cover

(Storm 4, Storm 4 Max)

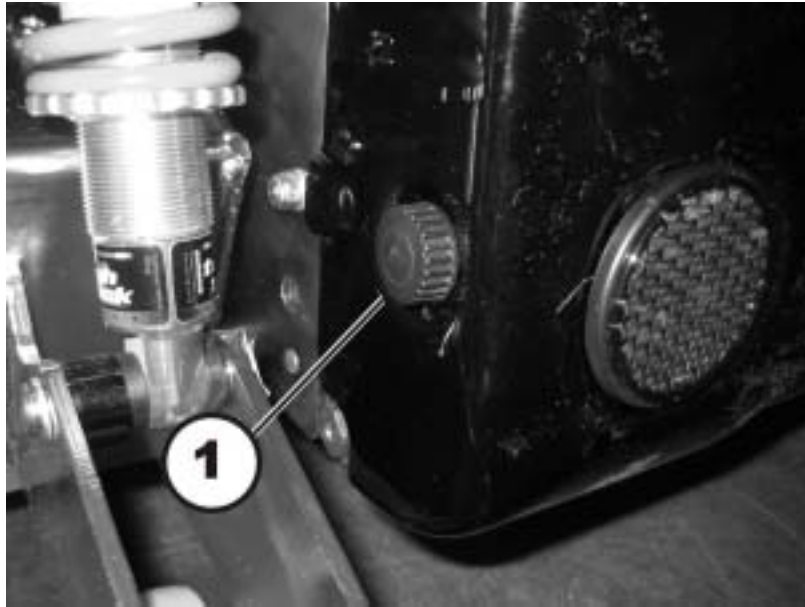

#### Removing the rear cover:

- Loosen and remove the two knurled screws (1) on the left and right side of the rear casing.
- Lift the rear cover carefully. The front part of the cover is held at the top by a Velcro strip. This must also be released.

### Fitting the rear cover:

- Fit the parts in the reverse order.
- Tighten the two knurled screws by hand.

## 12.3.2 Making the batteries accessible



---

### WARNING!

#### Fire and burn hazard due to short circuit at battery poles!

- *DO NOT short-circuit the battery poles with a tool or metal parts of the wheelchair!*
  - *Make sure that the battery pole caps are attached at all times when you are not working on the battery poles.*
- 



---

### DANGER: Risk of crushing!

#### The batteries are very heavy. There is a risk of hand injury.

- *Be aware that the batteries are very heavy.*
  - *Handle the batteries with care.*
- 



---

### Prerequisites:

- You do not require any tools.
- 



---

### Note

When disassembling, pay attention to small parts such as screws and washers. Lay out all the small parts so that they can be reassembled in the correct sequence.

---

- Remove the rear cover as described in Section **12.3.1**.



- Push both locking bolts (1) inward and open the battery compartment cover.

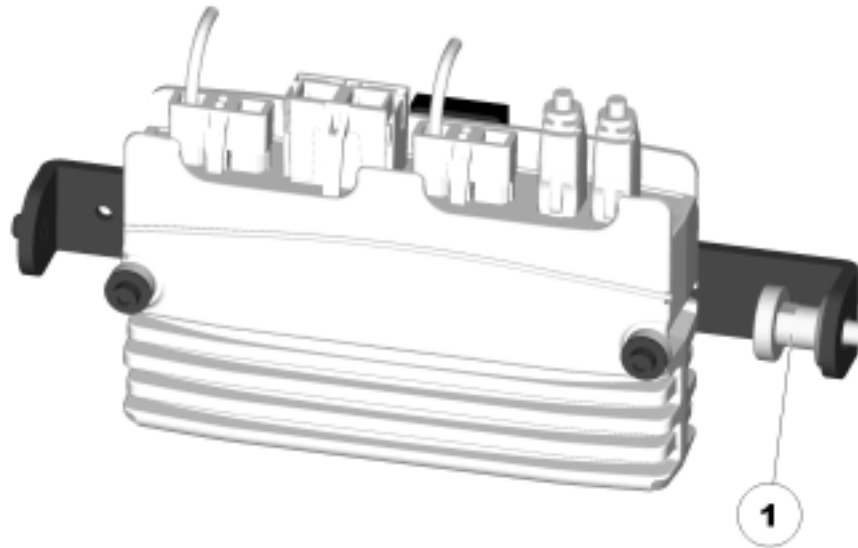

- Pull the latch (1) next to the power module to the left and then out.
- Lift the power module with the bracket, first to the right and then out to the left.
- Place the power module with the bracket on the upper surface of the battery box, or the actuator module, if present.
- Pull the batteries (1) and the battery mounting (2) by the strap (3) forwards to the end stop (see below).

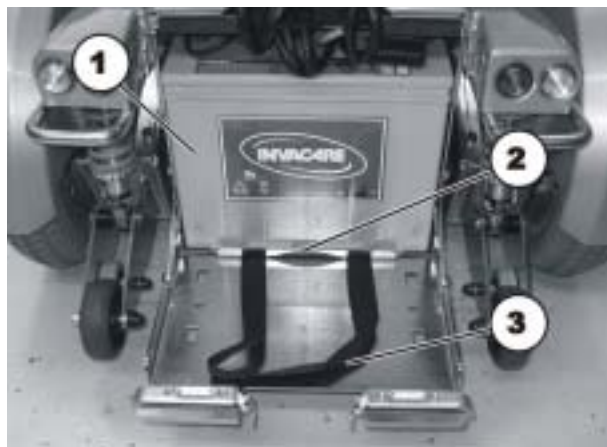

### 12.3.3 Removing/Installing the batteries



---

#### Requirements:

- 11-mm socket spanner
- 

#### Removing the batteries:

- Make the batteries accessible as described in chapter 12.3.2

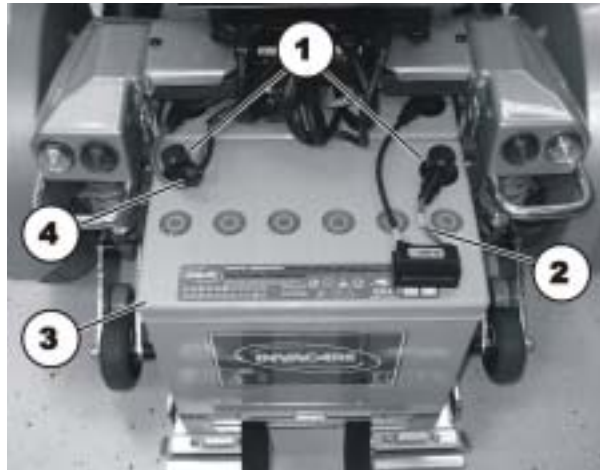

- Remove the pole caps (1) from the accessible battery (3).
- Remove the pole screws located under the pole caps using an 11-mm socket spanner.
- Remove the connection cable (4) and the fuse cable (2).



- Lift the battery from the battery carrier.
- Pull the second battery forward using its strap.
- Disconnect the cables of the second battery as well.
- Lift the second battery from the battery carrier.

**Fitting the batteries:**

- Fit the batteries in the reverse order.
- Ensure that the connectors and sockets in the battery compartment are fitted correctly. There is a polarity diagram in the rear cover.

## 13 Refurbishment

The product is suitable for refurbishment. Actions to be carried out:

- Cleaning and disinfection. Please see chapter "Maintenance" on page **86**.
- Inspection according to service plan. Please consult service instructions, available from Invacare®.
- Adaptation to the user. Please see chapter "Adjusting the wheelchair to the user's seating posture" on page **38**.

## 14 Disposal

- The equipment wrapping is potentially recyclable.
- The metal parts are used for scrap metal recycling.
- The plastic parts are used for plastic recycling.
- Electric components and printed circuit boards are disposed of as electronic scrap.
- Exhausted or damaged batteries can be returned to your medical equipment supplier or Invacare®.
- Disposal must be carried out in accordance with the respective national legal provisions.
- Ask your city or district council for details of the local waste management companies.

# 15 Technical specifications

The technical information provided hereafter applies to a standard configuration or represents maximum achievable values. These can change if accessories are added. The precise changes to these values are detailed in the sections for the respective accessories.

<b>Permissible operating and storage conditions</b>	
Temperature range for operation according to ISO 7176-9:	• -25° ... +50 °C
Temperature range for storage according to ISO 7176-9:	• -40° ... +65 °C

<b>Electrical system</b>	
Motors	• 350 W
Batteries	• 2 x 12 V/73.5 Ah (C20) leakproof/gel
Main fuse	• 80 A

<b>Charging device</b>	
Output current	8 A ± 8 %
Output voltage	24 V nominal (12 cells)
Input voltage	230 – 240 V
Operating temperature (surroundings)	-5° ... +40 °C
Storage temperature	-20° ... +50 °C

<b>Drive wheel tyres</b>	
Tyre type	• 14" pneumatic, puncture-protected or puncture-proof
Tyre pressure	The recommended maximum tyre pressure in bar or kpa is marked on the side wall of the tyre or the rim. If more than one value is listed, the lower one in the corresponding units applies. (Tolerance = -0.3 bar, 1 bar = 100 kpa)

<b>Castor wheel tyres</b>	
Tyre type	<ul style="list-style-type: none"> <li>• 10" pneumatic, puncture-protected or puncture-proof</li> </ul>
Tyre pressure	<p>The recommended maximum tyre pressure in bar or kpa is marked on the side wall of the tyre or the rim. If more than one value is listed, the lower one in the corresponding units applies. (Tolerance = -0.3 bar, 1 bar = 100 kpa)</p>

<b>Driving characteristics</b>	
Speed	<ul style="list-style-type: none"> <li>• 6 km/h</li> </ul>
Min. braking distance	<ul style="list-style-type: none"> <li>• 1000 mm</li> </ul>
Max. safe slope *****:	<ul style="list-style-type: none"> <li>• 6° (10.5 %) according to manufacturer's specifications with 220 kg payload, 4° seat angle, 20° backrest angle</li> </ul>
Max. climable obstacle height	<ul style="list-style-type: none"> <li>• 60 mm</li> </ul>
Turning diameter	<ul style="list-style-type: none"> <li>• 2080 mm</li> </ul>
Turning width	<ul style="list-style-type: none"> <li>• 1440 mm</li> </ul>
Drive range in accordance with ISO 7176-4:2008 ***	<ul style="list-style-type: none"> <li>• 31 km</li> </ul>

<b>Dimensions</b>	
Total height	<ul style="list-style-type: none"> <li>• 1195 mm</li> </ul>
Max. total width (widest point in parentheses)	<ul style="list-style-type: none"> <li>• 855 mm (seat width 49)</li> <li>• 915 mm (seat width 55)</li> <li>• 975 mm (seat width 61)</li> </ul>
Total length (incl. standard legrests)	<ul style="list-style-type: none"> <li>• 1390 mm</li> </ul>
Total length (without standard legrests)	<ul style="list-style-type: none"> <li>• 1020 mm</li> </ul>
Seat height ****	<ul style="list-style-type: none"> <li>• 480/510 mm</li> </ul>

<b>Dimensions</b>	
Seat width (armrest adjustment range in parentheses)	<ul style="list-style-type: none"> <li>• 490 mm (490 - 590 mm)</li> <li>• 550 mm (550 - 650 mm)</li> <li>• 610 mm (610 - 710 mm)</li> </ul>
Seat depth	<ul style="list-style-type: none"> <li>• 560/600/630 mm</li> </ul>
Backrest height ****	<ul style="list-style-type: none"> <li>• 570 - 620 mm (seat width 49)</li> <li>• 630 - 680 mm (seat width 55/61)</li> </ul>
Backrest angle	<ul style="list-style-type: none"> <li>• 0° ... +25°</li> </ul>
Armrest height	<ul style="list-style-type: none"> <li>• 250-340/290-380 mm</li> </ul>
Seat angle, electrical adjustment	<ul style="list-style-type: none"> <li>• 0° - 15°</li> </ul>
Seat angle, manual adjustment	<ul style="list-style-type: none"> <li>• 0° - 9°</li> </ul>
Legrest length	<ul style="list-style-type: none"> <li>• 360 - 480 mm</li> </ul>
Legrest angle	<ul style="list-style-type: none"> <li>• 50°</li> </ul>

<b>Weight</b>	
Kerb weight *****	<ul style="list-style-type: none"> <li>• min. 175 kg</li> </ul>

<b>Component weights</b>	
Batteries	<ul style="list-style-type: none"> <li>• approx. 24 kg per battery</li> </ul>

<b>Payload</b>	
Max. payload	<ul style="list-style-type: none"> <li>• 220 kg</li> </ul>

<b>Axle loads</b>	
Max. front axle load	<ul style="list-style-type: none"> <li>• 200 kg</li> </ul>
Max. rear axle load	<ul style="list-style-type: none"> <li>• 300 kg</li> </ul>

\*\* Width adjustable for side panel adjustment

\*\*\* Note: The drive range of an electric wheelchair is strongly influenced by external factors, such as the charging state of the batteries, surrounding temperature, local topography, road surface characteristics, tyre pressure, weight of user, drive style and use of batteries for lighting, servos etc.

The specified values are theoretical maximum achievable values measured according to ISO 7176-4:2008.

\*\*\*\* Measured without seat cushion

\*\*\*\*\* The actual kerb weight depends on the fittings your mobility aid has been supplied with. Every Invacare® mobility aid is weighed when leaving the works. Please refer to the nameplate for the kerb weight (including batteries) measured.

\*\*\*\*\* Static stability according to ISO 7176-1 = 9° (15.8 %)  
Dynamic stability according to ISO 7176-2 = 6° (10.5 %)

# 16 Inspections Performed

It is confirmed by stamp and signature that all jobs listed in the inspection schedule of the Service and Repair Instructions have been properly performed. The list of the inspection jobs to be performed can be found in the Service Manual which is available through Invacare®.

<u>Delivery Inspection</u>	<u>1<sup>st</sup> Annual Inspection</u>
Stamp of authorised Dealer / Date / Signature	Stamp of authorised Dealer / Date / Signature
<u>2<sup>nd</sup> Annual Inspection</u>	<u>3<sup>rd</sup> Annual Inspection</u>
Stamp of authorised Dealer / Date / Signature	Stamp of authorised Dealer / Date / Signature
<u>4<sup>th</sup> Annual Inspection</u>	<u>5<sup>th</sup> Annual Inspection</u>
Stamp of authorised Dealer / Date / Signature	Stamp of authorised Dealer / Date / Signature

Order No. of this Manual: 1547067.DOC  
Release Date: 2014-04-08

**English**