

Congratulations on your purchase of TwinTube® UBI (U-Build-It™). The TwinTube® UBI system is a highly stable, balanced, and strong receiver load carrying structure.

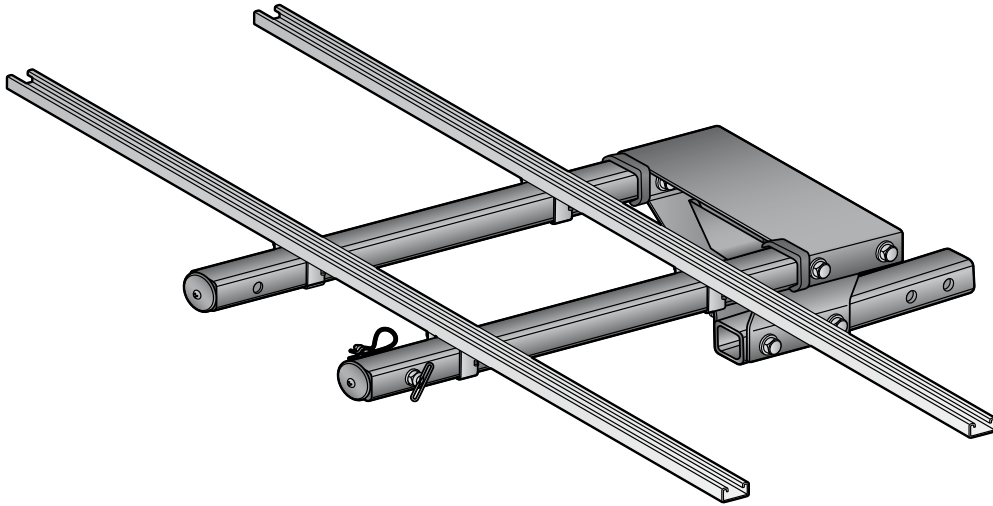

The TwinTube® UBI system features separate components that extend and enhance the load carrying capabilities of a receiver style hitch.

- The Spine assembly, which provides UBI's structural strength and telescope support.
- The Frame assembly which provides UBI's carrier, platform or box mounting interface and telescoping function.
- Safety Cable Quick Links allow the Frame and Spine system components to be separated, thereby dividing the UBI's weight in half. This provides ease-of-use when installing or removing and storing the system.

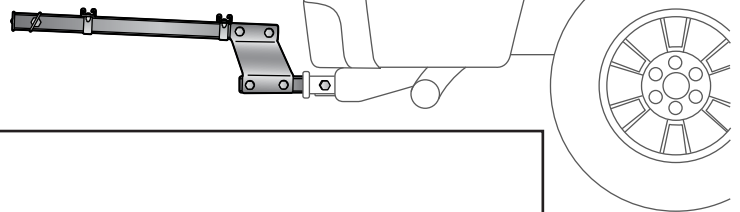

Installation Tips:

- Keep this manual for future reference.
- The TwinTube® UBI system fits a 2" size receiver style hitch and requires a minimum of a Class II tow rating.
- Keep in mind that the TwinTube® is a precision built product and some consideration of "alignment" is necessary when first assembling the system. The TwinTube® uses "symmetry" in a balanced manner, so when bolting the system together for the first time, tighten all hardware in a two step process - first tighten the assembly to set the components in position and then, when the TwinTube® is installed, securely tighten all hardware.

PARTS IDENTIFICATION

Parts List

Item	Description	Quantity
A	Shank	1
B	V-Plates	2
C	Top Plate	1
D	Telescope Tubes	2
E	Fixed Tubes	2
F	Wings (44" C Channel)	2
G	Top Hat Brackets	4
H	5/16" x 1 1/4" Carriage Bolts	8
J	Hexhead Silent Hitch Pin® Assembly	1
K	Hand Tighten Silent Hitch Pin® Assembly	1
L	Safety Cable with 2 Quicklink Connectors	1
M	End Caps	2
N	End Cap & Reflector Assembly	2
P	1/2" Bolts	6
Q	1/2" Washers	12
R	1/2" Locking Nuts	6
S	1/4" Washers	8
T	1/4" Locking Nuts	4
V	Center Plate	1
W	1/4-20 x 1" Bolts	4
X	Slide Bumpers	2
	Paraffin Starter Wax	1
Z	5/16" Washers	8
AA	5/16" Nylock Nuts	8

Tools Needed

- 3/4" Wrench
- 3/4" Socket
- 1/4" Wrench or Socket
- 7/16" Wrench
- 1/2" Wrench or Socket

If you are missing any items, contact your sales agent if the product was assembled by them.
 If not, or if purchased from Let's Go Aero, please contact us at 1-877-GO-4-AERO (464-2376).

Spine Assembly

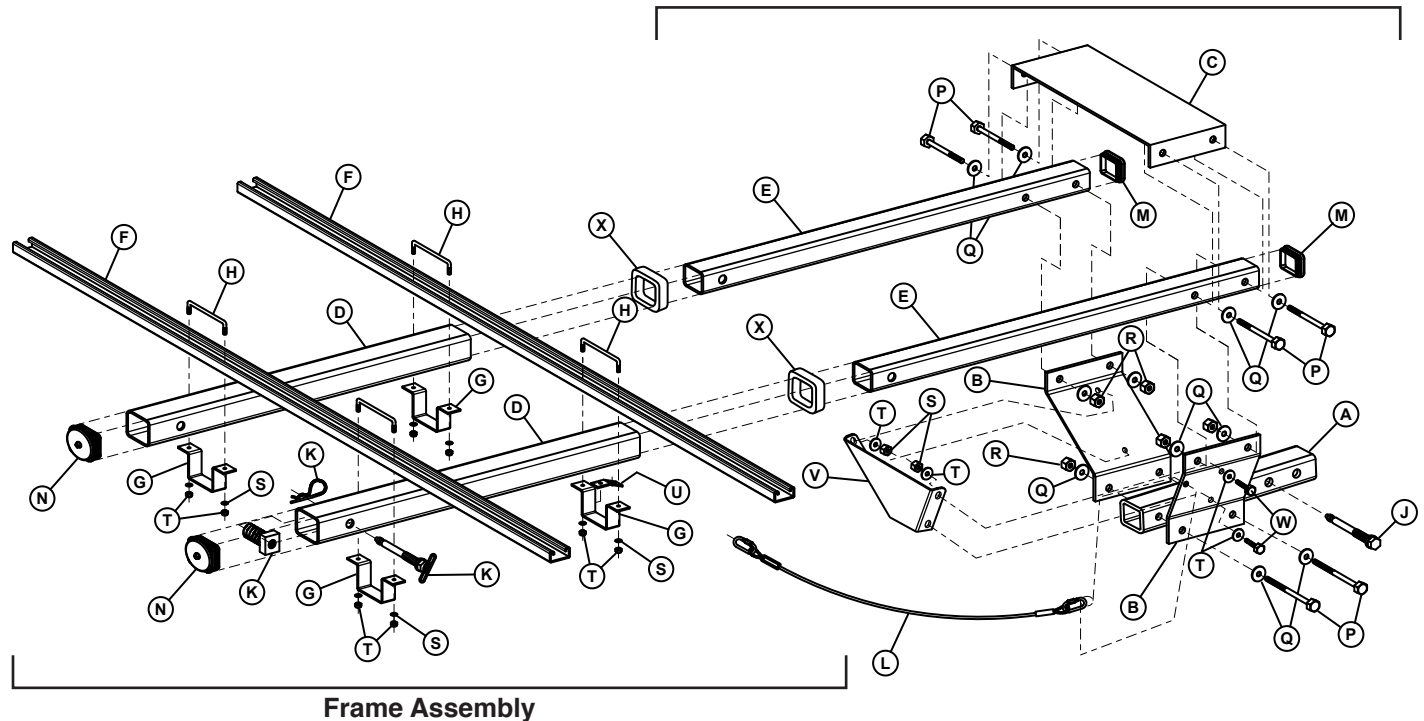

SILENT HITCH PIN® INSTALLATION

Two Silent Hitch Pins are included with TwinTube® UBI to prevent the inherent rattle that occurs when placing an accessory device (in this case, TwinTube® UBI) into the receiver hitch. The installation process is the same for both Silent Hitch Pins, the Hexhead Silent Hitch Pin® (J) secures the TwinTube® Assembly to the receiver hitch and the Hand Tighten Silent Hitch Pin® (K) secures the Frame Assembly to the Spine Assembly.



WARNING

The Silent Hitch Pins® must be firmly tightened to work properly. Make sure you use the Hexhead Silent Hitch Pin® (J) to attach the Shank to the receiver hitch and use a wrench to securely tighten it.

1. Orient the Shank (A) with the two 5/8" holes toward the receiver hitch on the vehicle. Insert the spring nut from the Hexhead Silent Hitch Pin® Assembly (J) into the Shank and line it up with the second hole from the end of the Shank (A).

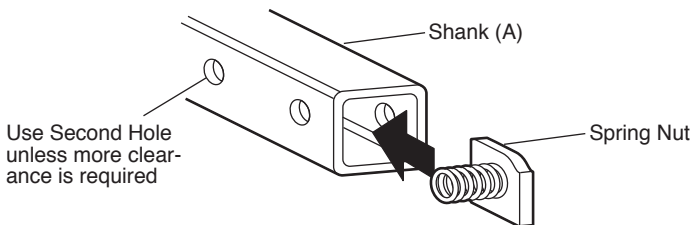

Note: Use the bolt hole in the Shank that places the TwinTube® as close to your vehicle as possible. If more clearance is needed use the last hole in the Shank.

2. Slide the Shank with the spring nut installed into the vehicle hitch and line up the Shank's bolt holes with the hole in the hitch.
Make sure the washer is on the Hexhead Silent Hitch Pin® (J) and thread it into the threaded spring nut. Use a wrench to securely tighten the Hexhead Silent Hitch Pin® (J) to 30 ft. lbs – 60 ft. lbs. of torque (equivalent to tightening a lug nut on a car wheel). Install the pin clip from the assembly.

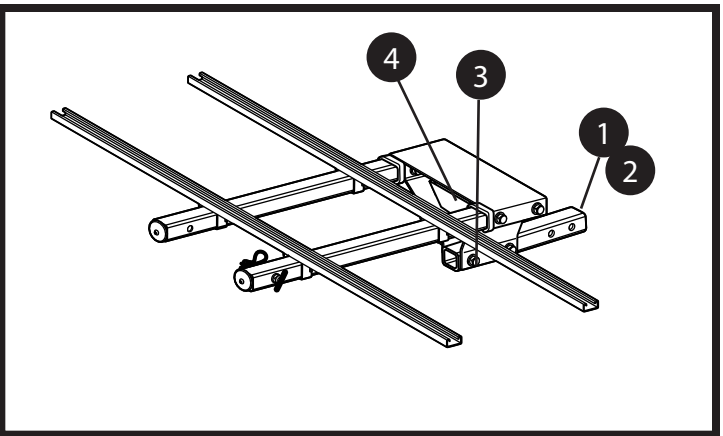
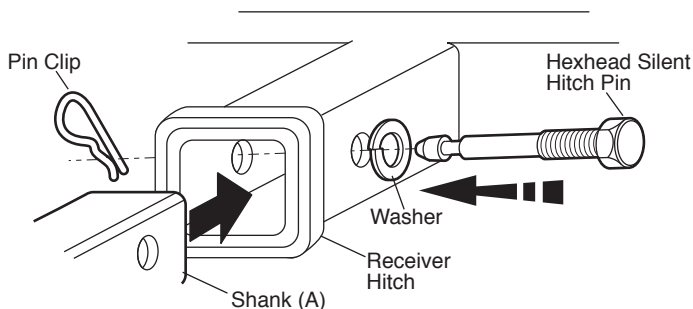

SPINE ASSEMBLY

3. The V-Plate (B) with the Safety Cable hole goes on the passenger side of the Shank (A). Orient both V-Plates (B) so that they angle up and away from the Shank (A) and the lower holes in the plates line up with the 1/2" holes in the Shank. Install a 1/2" Bolt (P), two 1/2" Washers (Q) and a 1/2" Locking Nut (R) in each hole. Use a 3/4" Wrench and a 3/4" Socket to position tighten the bolts.

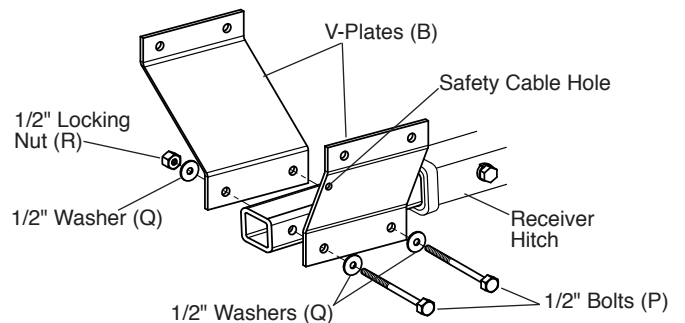

Note: V-Plates MUST be attached angled AWAY from the vehicle for product to install properly.

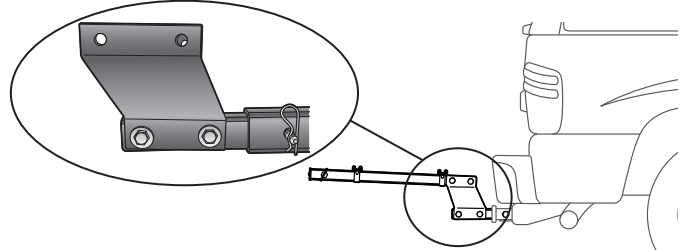

4. Place the Center Plate (V) between the V-Plates. Install a 1/4-20 x 1" Bolt (W), two (2) 1/4" Washers (S) and a 1/4" Locking Nut (T) in each hole. Then tighten the bolts on the Center Plate.

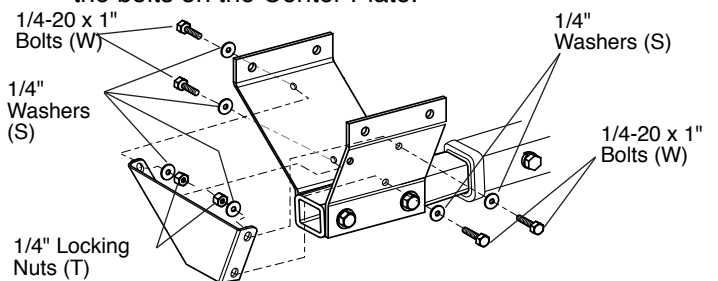

5. Place the Fixed Tubes (E) between the top of the V-Plates (B) and place the Top Plate (C) on top. Install a 1/2" Bolt (P), two 1/2" Washers (Q) and a 1/2" Locking Nut (R) in each hole (2 per Tube). Use a 3/4" Wrench and a 3/4" Socket to position tighten the bolts.

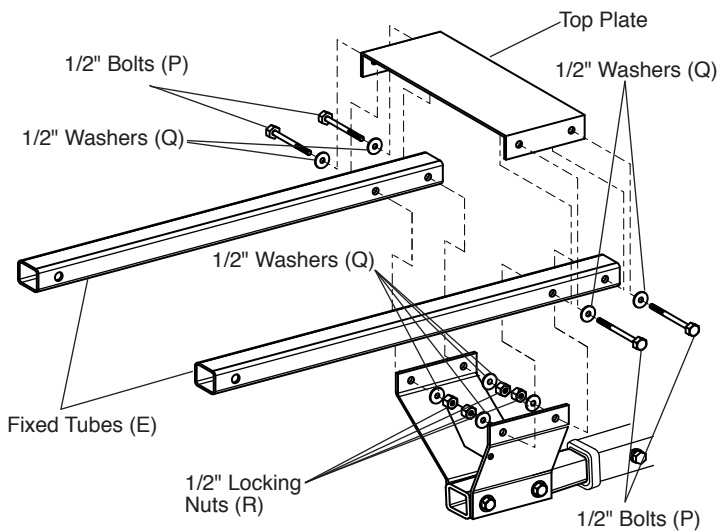

6. Securely tighten the bolts that attach the V-Plates (B) to the Shank (A). Make sure that the bolts are so tight that it is difficult to tighten them further using hand tools. Then snug tighten the bolts on the Center Plate to 12 ft. lbs.

7. Place a Slide Bumper (X) over each Fixed Tube and slide them back against the Top Plate.

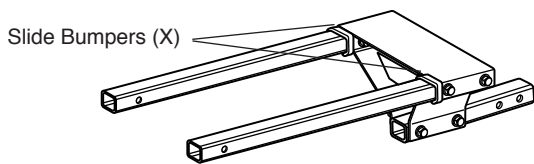

8. Insert the spring nut from Hand Tighten Silent Hitch Pin Assembly (K) into the Telescope-Safety pin hole on one of the Fixed Tubes (E). Line up spring nut hole with the Telescope-Safety Pin hole.

Note: It does not matter which Fixed Tube is used.

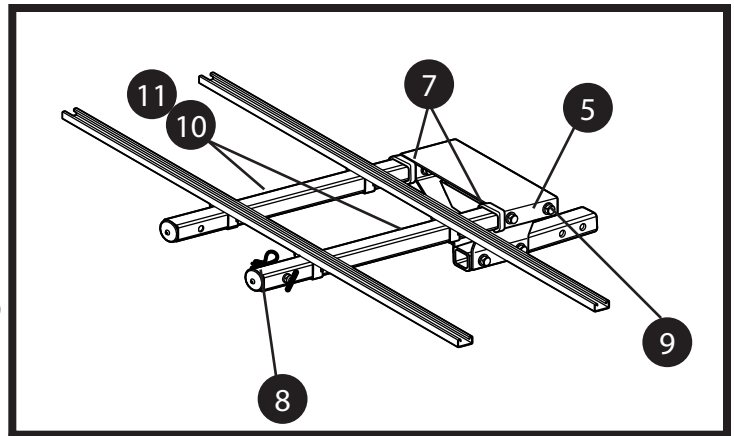
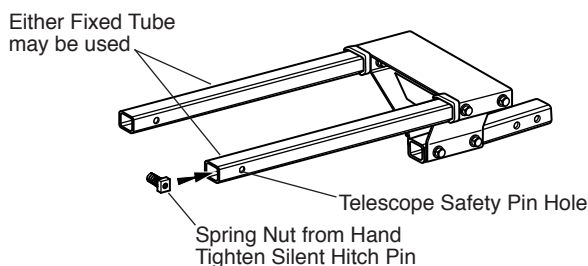

9. Securely tighten the bolts that attach the Fixed Tubes (E) to the V-Plates (A). Make sure that the bolts are so tight that it is difficult to tighten them further using hand tools.



Caution

Periodically check that the bolts are tight to ensure TwinTube® performs as designed.

10. Rub the top, sides and corners of the Spine's Fixed Tubes (E) with the enclosed bar of Paraffin Wax. This reduces friction, provides telescope smoothness, and protects the powder coated paint from wear. You will find that TwinTube's Paraffin Wax is a great solution to clean, hassle-free operation. Once applied, it stays put and stays clean.

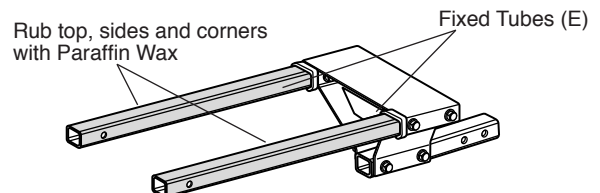

FRAME ASSEMBLY

11. Locate the Telescope Tubes (D) and orient them to the Spine Assembly with the weld seam down and with the hole away from the Spine. The hole in each Telescope Tube (D) must line up with the hole in the Fixed Tube (E).

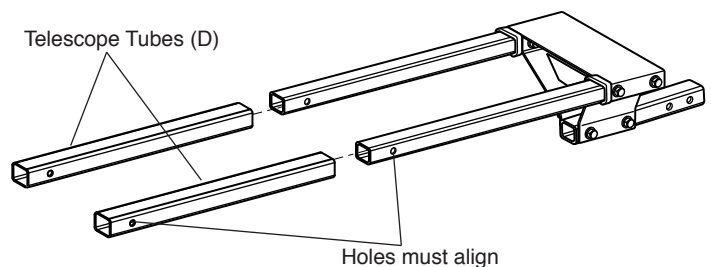

12. The two 44" Wings (F) form the mounting surface of the TwinTube UBI®. The Wings are adjustable for different platform widths, but they must be at least 12" apart to support a load properly.

The first Wing (F) should be mounted as close to the Top Plate (C) of the Spine Assembly as possible, depending on spare tires or ladders on the vehicle.

To mount this Wing, place four 5/16" Carriage Bolts (H) with 1" Bolts running through the pre-drilled square mounting holes in the bottom of the Wing channel and position the Wing on the Telescope slide tubes. Thread a Carriage Bolt (H) through the Safety Cable on the passenger side and a Top-Hat Bracket (G) over the Carriage Bolt threads. Secure the Brackets with a 5/16" Washer (Z), and a 5/16" Nylock Nut (AA) at each Carriage Bolt.

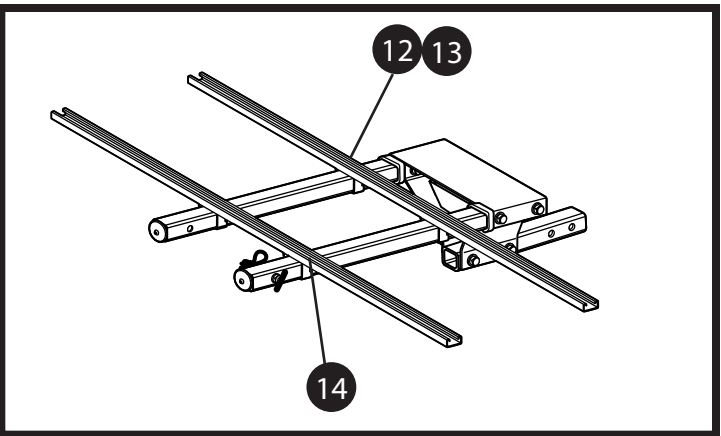

Caution

The Wings must fit squarely on the Telescope Tubes for the Bolts to tighten correctly and for the telescope feature to operate freely. Tighten the Top Hat Brackets so that the ears deflect into a slight bend.



WARNING

The 44" Wings must be at least 12" apart to support a load properly.

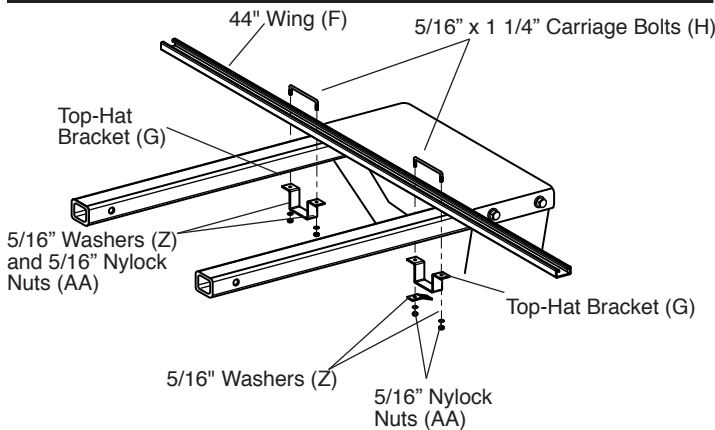

14. Repeat Steps 12 and 13 with the rear Wing (F). Leave the Carriage Bolts (H) and Nylock Nuts (AA) loose enough so the Wing can move forward or back as needed to fit the bolt hole pattern of the platform you intend to mount on UBI. You may adjust both Wings along the Frame tube as needed to accommodate your platform of choice, as well as for additional clearance to accommodate spare tires, etc. on the back of your vehicle.

Note: After installing your platform of choice to the Wings, the last step is to firmly tighten all the 5/16 Nylock Nuts securing the Top-Hat Brackets to the Wings. Tighten these in a balanced fashion until securely snug. Between uses, periodically re-check these fasteners for proper tightness.

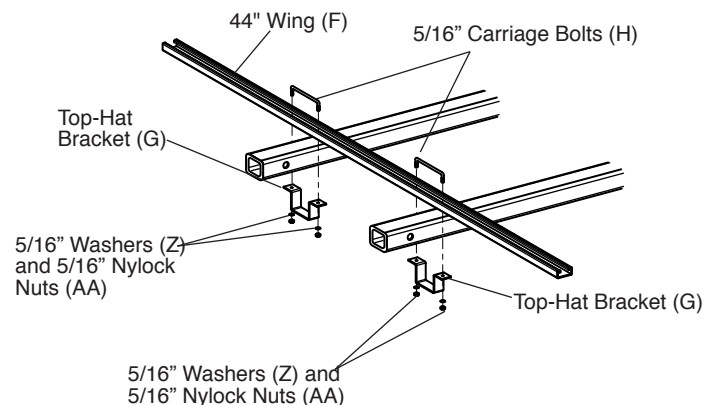

13. Check that the Telescope Tubes (D) are as far toward the vehicle as possible and that the Telescope Pin holes in the rear of the Spine and Telescope Tubes (D) are aligned. When everything is aligned, tighten the 5/16" Nylock Nuts (AA) on the Carriage Bolts (H). Tighten the 5/16" Nylock Nuts alternating from side to side so each side of the Top-Hat Bracket is equally compressed around the Telescope Tube (D). Use a 1/2" wrench to snug tighten the nuts to 12 ft. lbs.

Slide the Frame back and forth on the Spine to check the alignment. If any binding is observed, check to be sure that the Telescope Tubes (D) both come to rest against the Top Plate on the Spine and that the Wing is mounted "squarely". If not, loosen the Top Hat Bracket fasteners and reposition the Wing (F).

15. Attach the Safety Cable (L) to the passenger side V-Plate (B) with the hardware attached to the cable. This will ensure that the Frame cannot slide off the Spine inadvertently. To remove the Frame and carrier from the Spine, simply undo one Quick Link. This allows TwinTube® to be separated into its two component parts to ease the installation, removal and storage. of the system.

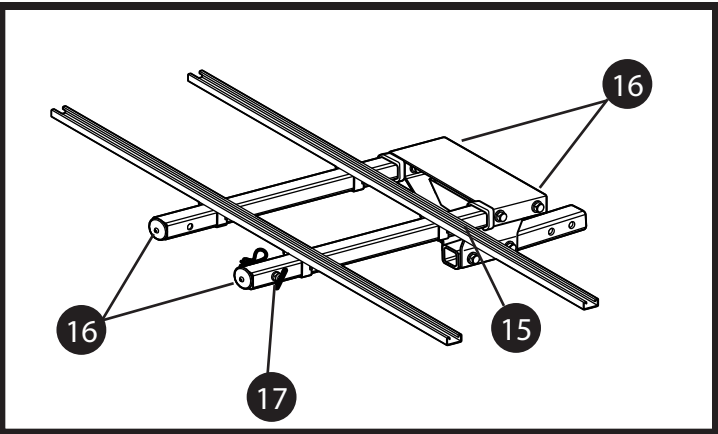
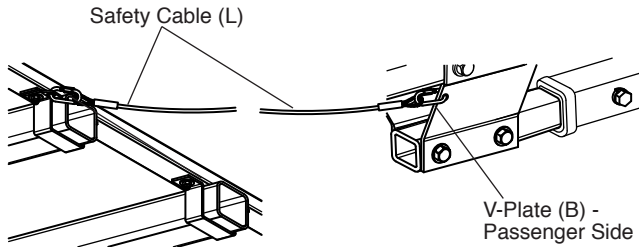

17. The Hand Tighten Silent Hitch Pin® (K) with the handle is for securing TwinTube's Frame to the Spine during use. When this pin is engaged, it helps prevent carrier movement or wobble. When in transit, it prevents the Frame from sliding rearward on the Spine. Be sure to use the 1/4" x 5/8" nylon bushing on the Silent Hitch Pin® assembly to prevent any scratching or marring of the powder coated finish on the Telescope Tube (D). To install, thread the Hand Tighten Silent Hitch Pin® (K) into the spring nut that was installed in Step 6. Install the pin clip from the assembly.

16. Install the End Caps (M) without reflectors into the ends of the Fixed Tubes (D) closest to the vehicle and the End Cap and Reflector Assemblies (N) into the ends of the Telescope Tubes at the rear of TwinTube® (farthest from vehicle for view from behind).

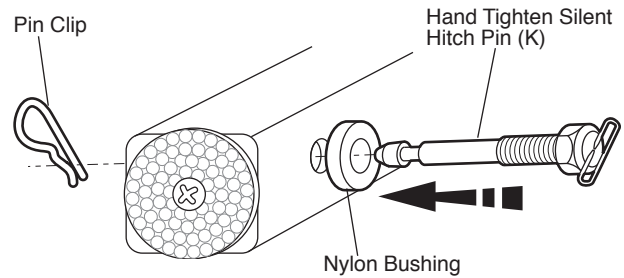
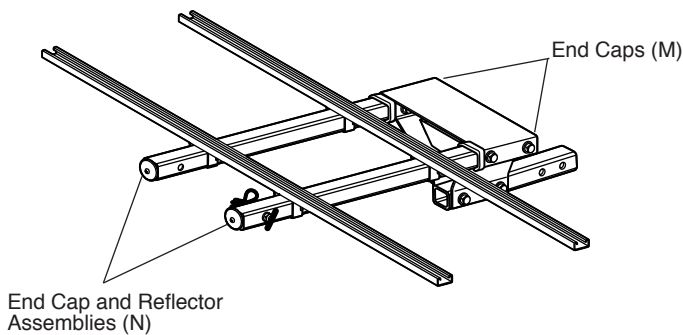

WARNING

The Hand Tighten Silent Hitch Pin **MUST** be firmly secured in Telescope-Safety pin hole location before transit. Failure to do so may result in potential hazards from improper operation, including property damage and bodily injury.

WARNING

Never move your vehicle with the TwinTube® UBI extended in the telescoped position. It must always be properly secured before transit. Failure to do so may result in potential hazards from improper operation, including property damage and bodily injury.

Note: Up to 6" of additional rear rack clearance may be achieved by setting the Wings rearward along the TwinTube as shown below. Do NOT position beyond the Telescope Bolt hole location; the Hand-Tighten Silent Hitch Pin must remain rearward of the Wings at all times.

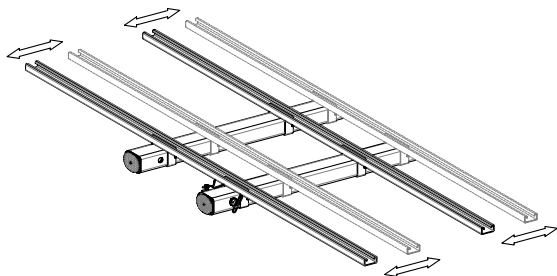

SAFE USE & OPERATION

This information is pertinent to TwinTube® UBI and any platform it supports including carriers by Let's Go Aero. Be sure to follow these guidelines to prevent possible hazards from misuse.

Vehicle and Hitch Receiver Compliance

This TwinTube® UBI hitch rack fits 2" size hitch receivers and is rated for a Class II tow capability or higher (Class II, III and up). When operating a tow accessory (any item inserted into the hitch receiver), you must comply with the vehicle and hitch receiver's towing parameters. Consult your vehicle and hitch receiver owner manual(s) for details on your tow and tongue weight parameters. Be sure that they are compatible with TwinTube® UBI and your platform of choice's weight specifications.

Tongue Weight Compliance

TwinTube® UBI and any platform installed on this support structure creates a combined weight that creates direct downward pressure on the hitch receiver's tongue. This downward pressure is the tongue weight. Tongue weight is one of the two critical weight rating factors of your tow rating's classification (Class I, II, III, IV, V). **Never exceed your vehicle and hitch receiver's tongue weight specification.**

TwinTube® UBI Weight and Load Parameters

TwinTube® UBI weighs 48 lbs unloaded. To determine your available load weight in accordance with your vehicle and hitch receiver's tongue weight rating, subtract TwinTube's 48 lbs from your identified tongue weight rating. The difference represents your vehicle and hitch receiver's available load weight.

TwinTube® UBI is rated for up to 300 lbs of carrying capacity. This weight includes any platform installed on TwinTube® UBI as well as the cargo itself.

When transporting cargo, place heavy loads in the center and lighter cargo to the outside. The 44" Wings must be at least 12" apart to support a load properly.

The rearward load length should not exceed the overall surface space provided by the TwinTube® UBI structure. The Wings are adjustable; however, always keep the load as close to the vehicle as possible. Keep in mind that the further your load is from the hitch receiver, the greater your downward pressure (tongue weight). For each one foot rearward, approximately twenty percent of your hitch receiver's tongue weight is diminished.

Telescoping TwinTube® UBI

To telescope the TwinTube® UBI, remove the Hand Tighten Silent Hitch Pin® from the Telescope Safety pin hole. Verify that the Safety Cable is secured and then slide the frame to the rear.



WARNINGS

Failure to adhere to these recommendations may result in potential hazards from improper operation, including property damage and bodily injury.

- **Engage Silent Hitch Pins®**

Both pins **MUST** be securely engaged before transit. A wrench **MUST** be used to tighten the Hexhead Silent Hitch Pin® at the hitch receiver location.

- **Secure the TwinTube® UBI as close to vehicle as possible**

Always secure TwinTube® UBI as close to your vehicle as possible, minimizing the distance of this structure and its load from your vehicle. There are two bolt hole settings (5 3/4" and 8" positions) from which to choose. You may also adjust the Wings for up to 10" of rear installed clearance from your vehicle as needed. See Step 10 of this User Manual for Wing adjustment.

- **Verify that the Safety Cable is Secured**

The Safety Cable prevents the Frame from sliding off the Spine when telescoping the TwinTube®. It should always be engaged for this reason, and to prevent the cable from dragging on the ground while in transit.

- **Never move your vehicle with the TwinTube® UBI extended in the telescoped position.**

The TwinTube® UBI must always be properly secured before transit.

We warrant this product to the first consumer to be free from defect in material and workmanship for one year (Please retain your sales slip for your records). Any product or part thereof found to be defective within that period will be replaced without charge provided that: (1) the product was not misused; (2) no alterations or modifications were made; (3) its failure resulted from a defect in material or workmanship and not from normal wear expected in the use of the product; (4) the product or part is delivered, freight prepaid, to Let's Go Aero. Please contact Let's Go Aero, toll free, at 877-464-2376 to get a return authorization number prior to return. Manufacturers only obligation shall be to replace such products or parts proved to be defective.