

# **DNR Super High Resolution Day & Night Color Camera**

**1/3" INTERLINE TRANSFER CCD  
HIGH RESOLUTION**





*Please read this manual thoroughly before use and keep it handy for future reference.*

# WARNINGS AND CAUTIONS

TO REDUCE THE RISK OF FIRE OR ELECTRIC SHOCK, DO NOT EXPOSE THIS PRODUCT TO RAIN OR MOISTURE. DO NOT INSERT ANY METALLIC OBJECT THROUGH THE VENTILATION GRILLS OR OTHER OPENINGS ON THE EQUIPMENT.

## CAUTION

	<b>CAUTION</b> RISK OF ELECTRIC SHOCK DO NOT OPEN	
<b>CAUTION : TO REDUCE THE RISK OF ELECTRIC SHOCK, DO NOT REMOVE COVER(OR BACK). NO USER-SERVICABLE PARTS INSIDE. REFER SERVICING TO QUALIFIED SERVICE PERSONNEL.</b>		

## EXPLANATION OF GRAPHICAL SYMBOLS



The lightning flash with arrowhead symbol, within an equilateral triangle, is intended to alert the user to the presence of uninsulated "dangerous voltage" within the product's enclosure that may be of sufficient magnitude to constitute a risk of electric shock to persons.



The exclamation point within an equilateral triangle is intended to alert the user to the presence of important operating and maintenance (servicing) instructions in the literature accompanying the product.

## PRECAUTIONS

### Safety

Should any liquid or solid object fall into the cabinet, unplug the unit and have it checked by qualified personnel before operating it any further.

Unplug the unit from the wall outlet if it is not going to be used for several days or more.

To disconnect the cord, pull it out by the plug. Never pull the cord itself.

Allow adequate air circulation to prevent internal heat build-up. Do not place the unit on soft surfaces (rugs, carpets, sofas, etc.) or near materials (curtains, draperies) that may block the ventilation holes.

Height and vertical linearity controls located on the rear panel are for special adjustments by qualified personnel only.

### Installation

Do not install the unit in an extremely hot or humid place or in a place subject to excessive dust, mechanical vibration.

The unit is not designed to be waterproof. Exposure to rain or water may damage the unit.

### Cleaning

Clean the unit with a slightly damp soft cloth. Use a mild household detergent. Never use strong solvents such as thinner or benzine as they might damage the finish of the unit.

Retain the original carton and packing materials for safe transport of this unit in the future.

# FCC COMPLIANCE STATEMENT

---

**INFORMATION TO THE USER:** THIS EQUIPMENT HAS BEEN TESTED AND FOUND TO COMPLY WITH THE LIMITS FOR A CLASS A DIGITAL DEVICE, PURSUANT TO PART 15 OF THE FCC RULES. THESE LIMITS ARE DESIGNED TO PROVIDE REASONABLE PROTECTION AGAINST HARMFUL INTERFERENCE WHEN THE EQUIPMENT IS OPERATED IN A COMMERCIAL ENVIRONMENT. THIS EQUIPMENT GENERATES, USES, AND CAN RADIATE RADIO FREQUENCY ENERGY AND IF NOT INSTALLED AND USED IN ACCORDANCE WITH THE INSTRUCTION MANUAL, MAY CAUSE HARMFUL INTERFERENCE TO RADIO COMMUNICATIONS. OPERATION OF THIS EQUIPMENT IN A RESIDENTIAL AREA IS LIKELY TO CAUSE HARMFUL INTERFERENCE IN WHICH CASE THE USER WILL BE REQUIRED TO CORRECT THE INTERFERENCE AT HIS OWN EXPENSE.

**CAUTION:** CHANGES OR MODIFICATIONS NOT EXPRESSLY APPROVED BY THE PARTY RESPONSIBLE FOR COMPLIANCE COULD VOID THE USER'S AUTHORITY TO OPERATE THE EQUIPMENT.

THIS CLASS A DIGITAL APPARATUS COMPLIES WITH CANADIAN ICES-003.

CET APPAREIL NUMÉRIQUE DE LA CLASSE A EST CONFORME À LA NORME NMB-003 DU CANADA.

# CE COMPLIANCE STATEMENT

---

**WARNING:** This is a Class A product. In a domestic environment this product may cause radio interference in which case the user may be required to take adequate measures.

# IMPORTANT SAFETY INSTRUCTIONS

---

1. Read these instructions.
2. Keep these instructions.
3. Heed all warnings.
4. Follow all instructions.
5. Do not use this apparatus near water.
6. Clean only with dry cloth.
7. Do not block any ventilation openings. Install in accordance with the manufacturer's instructions.
8. Do not install near any heat sources such as radiators, heat registers, stoves, or other apparatus (including amplifiers) that produce heat.
9. Do not defeat the safety purpose of the polarized or grounding-type plug. A polarized plug has two blades with one wider than the other. A grounding type plug has two blades and a third grounding prong. The wide blade or the third prong are provided for your safety. If the provided plug does not fit into your outlet, consult an electrician for replacement of the obsolete outlet.
10. Protect the power cord from being walked on or pinched particularly at plugs, convenience receptacles, and the point where they exit from the apparatus.
11. Only use attachments/accessories specified by the manufacturer.
12. Use only with the cart, stand, tripod, bracket, or table specified by the manufacturer, or sold with the apparatus. When a cart is used, use caution when moving the cart/apparatus combination to avoid injury from tip-over.
13. Unplug this apparatus during lightning storms or when unused for long periods of time.
14. Refer all servicing to qualified service personnel. Servicing is required when the apparatus has been damaged in any way, such as power-supply cord or plug is damaged, liquid has been moisture, does not operate normally, or has been dropped.
15. **CAUTION – THESE SERVICING INSTRUCTIONS ARE FOR USE BY QUALIFIED SERVICE PERSONNEL ONLY. TO REDUCE THE RISK OF ELECTRIC SHOCK DO NOT PERFORM ANY SERVICING OTHER THAN THAT CONTAINED IN THE OPERATING INSTRUCTIONS UNLESS YOU QRE QUALIFIED TO DO SO.**
16. Use satisfy clause 2.5 of IEC60950-1/UL60950-1 or Certified/Listed Class 2 power source only.



# CONTENTS OF PACKAGE

---

Installation of the camera must be performed by qualified service personnel in accordance with all local and national electrical and mechanical codes.

Carefully remove the color camera and its accessories from the carton and verify that they were not damaged in shipment.

The contents of the package includes:

1. Color CCD camera
2. Mini-DIN connector (for video-or dc-type auto-iris lens)
3. CS adapter ring for C mounting “C” lenses
4. This manual

# TABLE CONTENTS

---

INTRODUCTION-----	1
COMERA OVERVIEW-----	2
OSD MENU STRUCTURE-----	3
DC IRIS LENS-----	10
SPECIFICATIONS-----	11

# INTRODUCTION

---

The camera provides high-quality images using SONY 1/3" CCD and digital Signal process LSIs.

## Features:

- 1/3" EXview HAD CCD II for an image of high sensitivity
- Digital Wide Dynamic Range (Xtended Dynamic Range)
- Excellent picture quality
- 700 lines of resolution
- 0.15Lux(Color), 0.01Lux(B/W) @ F1.2 Sensitivity
- Auto electronic shutter [1/60(1/50) ~ 1/10,000] and manual electronic shutter modes
- OSD (On Screen Display)
- Auto and manual white balance modes
- Auto BLC and HLC
- Day & Night (Auto/Manual)
- Privacy Zone 4 point, Motion Detection 4 Point
- MIRROR, SHARPNESS, HUE, CONTRAST, GAIN
- AGC (Auto Gain Control)
- VIDEO OUT(BNC)
- Internal
- Quick connect for DC lens with 4-pin connector
- Operates in 12VDC or 24VAC
- Operates in 100-240VAC
- Use Certified / Listed Class 2 power source only.
- If using DC 12V power adaptor, Please use a power supply capable of supplying over 5.5 Watts.
- Auto White Defect



**IMPORTANT :** The user of this camera is responsible for checking and complying with local, state, and federal laws and statutes concerning the recording and monitoring of audio signals.

---

# CAMERA OVERVIEW

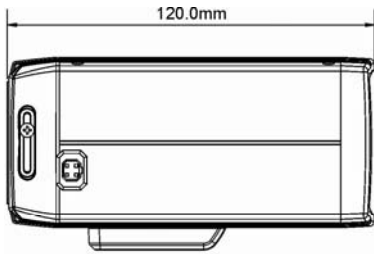

SIDE VIEW

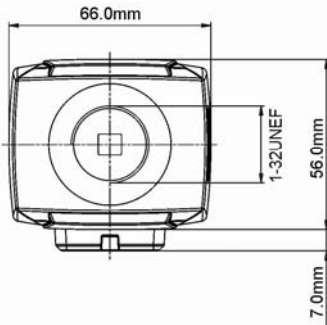

FRONT VIEW

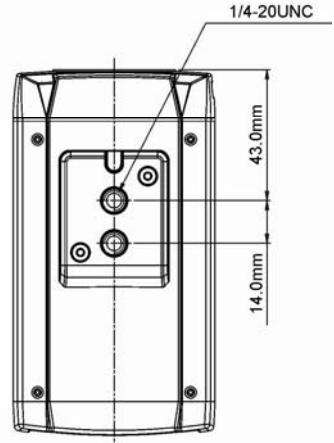

TOP VIEW

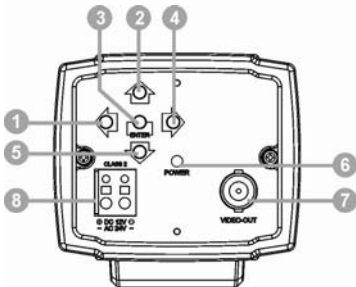

- ❶ Left Button
- ❷ Up Button
- ❸ Enter Button
- ❹ Right Button
- ❺ Down Button
- ❻ Power Indicator
- ❼ Video Output Connector (BNC)
- ❽ AC/DC Compatible Input Terminal
- ❾ AC Power Cord

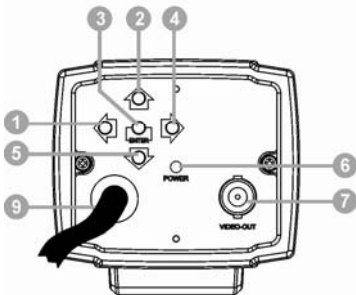

REAR VIEW

# OSD MENU STRUCTURE

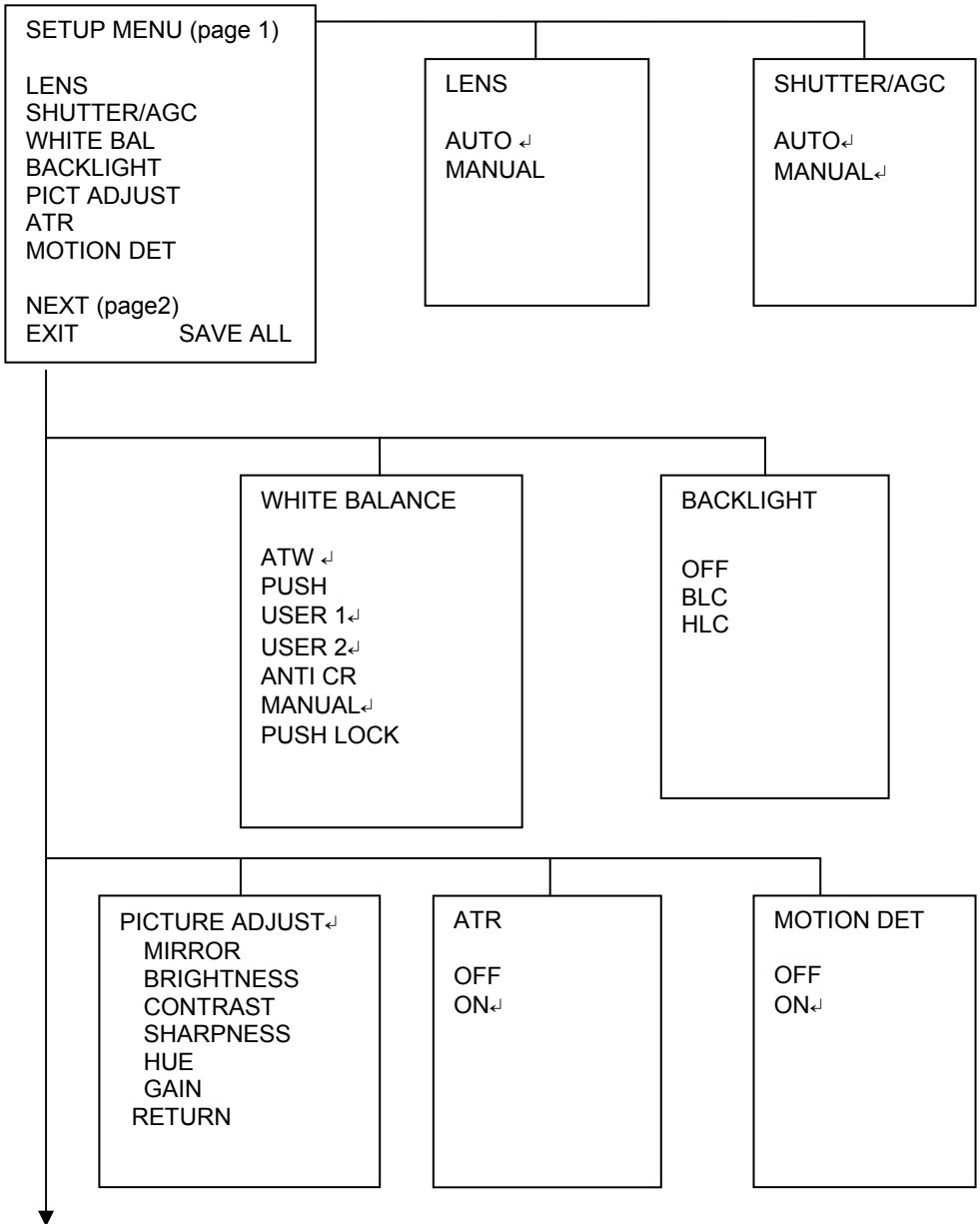



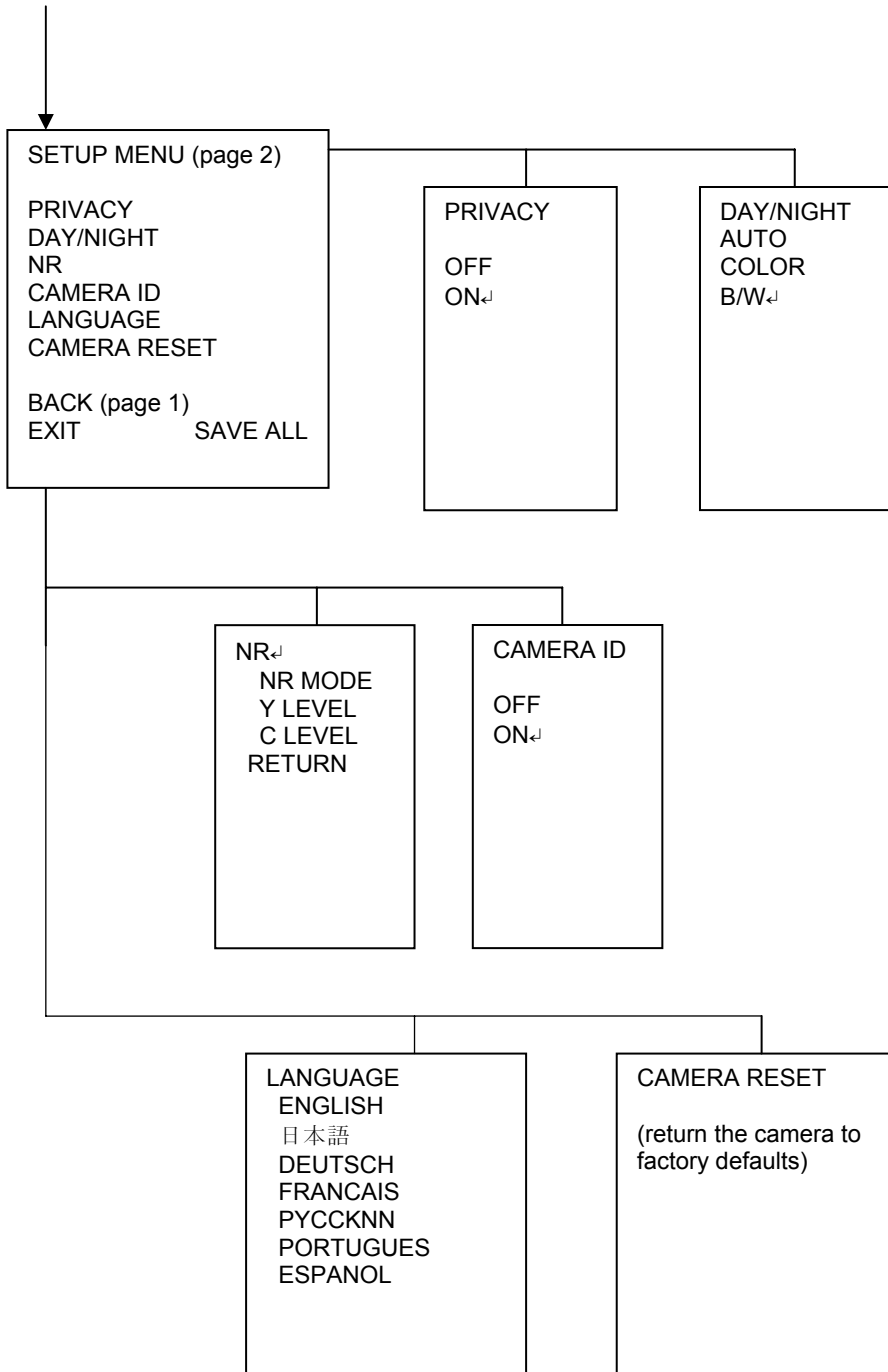

## LENS

---

### AUTO

**TYPE** (DC / VIDEO)

Sets the type of mechanical iris  
(Video lens is not supported)

**MODE** (AUTO / OPEN / CLOSE )

Sets the type of control to be applied over the mechanical iris.

**SPEED** (0 – 255)

Sets the convergence speed of the mechanical iris.

### MANUAL

Manual lens only

(**Note** Since Manual mode AUTO mode is changed SHUTTER/AGC to SHUT+AUTO IRIS when MANUAL is changed to AUTO, AUTO MODE should be changed to AUTO IRIS in SHUTTER/AGC)

## SHUTTER/AGC

---

### AUTO

#### **HIGH LUMINANCE**

**MODE** (SHUT+AUTO IRIS / AUTO IRIS)

(**Note**: only SHUT can be selected if LENS is in MANUAL mode  
SHUT+AUTO IRIS is AE(Auto Exposure) for SHUTTER is 1/500(1/480) and  
MIRIS)

**BRIGHTNESS** (0 ~ 255)

Adjusts the brightness

#### **LOW LUMINANCE**

**MODE** (AGC / OFF)

Auto Gain Control on or off

**BRIGHTNESS** (x0.25 / x0.50 / x0.75/ x1.00)

Amount of AGC applied in low lighting conditions

### MANUAL

**MODE** (SHUT+ AGC)

Auto gain control

**SHUTTER**

Select the shutter speed (1/60, 1/120, 1/250, 1/500, 1/1000, 1/2000, 1/4000, 1/10000)

**AGC**

Sets the AGC gain applied [dB] for ME (manual exposure)  
(6, 12, 18, 24, 30, 36, 42, 44.8dB)

## **WHITE BAL**

---

**ATW** (Auto Trace White balance)

**SPEED** (0~255)

Adjusts the pull-in speed of ATW.

**DELAY CNT** (0~255)

Sets the time-based hysteresis of ATW.

**ATW FRAME** (x0.5 / x1 / x1.5 / x2)

Sets the pull-in frame magnification.

**ENVIROMENT** (INDOOR / OUTDOOR)

Preset for either indoor or outdoor applications of the ATW

### **PUSH**

Wide range Auto White Balance mode (AWB)

### **USER1 & 2**

Both USER 1 & 2 can be individually set up for specific applications. The gain values for the outdoor fixed mode are used as the adjustment items of USER1 on the internal OSD menu.

**B-GAIN** (0~255)

**R-GAIN** (0~255)

### **ANTI CR**

Color rolling suppression

### **MANUAL**

The B and R gain values for manual WB are set on this screen.

**LEVEL** (NTSC : 13 ~ 56) , (PAL : 16 ~ 78)

### **PUSH LOCK**

PUSHLOCK is selected and the Enter input is active

### **BACKLIGHT**

---

Sharpens subjects with backlight (OFF / BLC / HLC)

### **PICT ADJUST**

---

**MIRROR** (OFF / ON) Horizontally inverts image.

**BRIGHTNESS** (0~255) Sets the screen brightness.

**CONTRAST** (0~255) Sets the screen contrast.

**SHARPNESS** (0~255) Sets the screen sharpness.

**HUE** (0~255) Adjusts the hue.

**GAIN** (0~255) Adjusts the gain.

## ATR

---

ATR (Adaptive Tone Reproduction) allows adjustment of the image to assist with widely contrasting scenes of view.

### LUMINANCE (LOW / MID / HIGH)

Sets the extent of the luminance compression

### CONTRAST (LOW / MIDLOW / MID / MIDHIGH / HIGH)

Sets the extent of the contrast enhancement

## MOTION DET

---

### DETECT SENSE (0~127)

Sets the motion detection sensitivity (0=low sensitivity, 127=high sensitivity)

### BLOCK DISP (OFF / ON / ENABLE)

Applies a Motion block trace in the selected area. To define the area, select Enable and push centrally on the joystick. Use the Joystick to navigate to the blocks you want to **Disable** and not include in motion trace. To return to the menu, push and hold central joystick for 2secs and release.

### MOTION AREA (ON / OFF)

Enables/disables the motion detection

### AREA SEL (1~4)

Selects the motion detection area

(**Note:** Set the area sel it would be better to move firstly BOTTOM and RIGHT)

**TOP** (NTSC:0~244 , PAL:0~288)

0 = top

**BOTTOM** (NTSC:0~244 , PAL:0~288)

244(288) = bottom

**LEFT** (NTSC:0~474 , PAL:0~468)

0 = left

**RIGHT** (NTSC:0~474 , PAL:0~468)

474(468) = right

	SE		111
BLOCK DISP		OFF	
MONITOR AREA		ON	
AREA SEL		1/4	
TOP			000
BOTTOM			076
LEFT			000
RIGHT			183
RETURN			

## PRIVACY

---

### AREA SEL (1~4)

Selects the motion detection area

(**Note:** Set the area sel it would be better to move firstly BOTTOM and RIGHT)

**TOP** (NTSC:0~244 , PAL:0~288)

0 = top

**BOTTOM** (NTSC:0~244 , PAL:0~288)

244(288) = bottom

PRIVACY	
AREA SEL	1/4
TOP	000
BOTTOM	077
LEFT	000
RIGHT	187
COLOR	1
TRANSP	1.00
MOSAIC	OFF
RETURN	

**LEFT** (NTSC:0~474 , PAL:0~468)

0 = left

**RIGHT** (NTSC:0~474 , PAL:0~468)

474(468) = right

**COLOR** (1~8)

Sets the colors of the privacy zones.

**TRANSP** (0.00 / 0.50 / 0.75 / 1.00)

Sets the transparency of the privacy zone area if color is selected.

**MOSAIC** (OFF / ON)

Sets the mosaic function as the privacy to ON or OFF.

(Note: when ON, transparency needs to be set at 0.00 and privacy zones can only be 1 color OR mosaic and not mixed)

## **DAY / NIGHT**

---

**COLOR** (color only operation)

**B/W** (monochrome only operation)

**BURST** (OFF / ON)

Allows the color burst signal in monochrome to be removed if required.

**IR OPTIMIZER** (OFF / ON)

Smart IR mode OFF or ON

**MODE** (ONLY IR OPTIMIZER ON, AUTO / CENTER)

Auto : Histogram integration mode

Center : Center priority mode

**LEVEL** (ONLY IR OPTIMIZER ON, 0~31)

## **NR (2D-DNR)**

---

This is used to remove noise from the image in low light conditions when AGC is applied.

**NR MODE** (OFF, Y, C, Y/C)

Sets the 2D NR filter mode.

**Y LEVEL** (0-15)

Sets the Y filter (Luminance) strength.

**C LEVEL** (0-15)

Sets the C filter (Chrominance) strength.

## **CAMERA ID**

---

Sets the camera ID to ON or OFF. A title of 52 characters per line can be applied.

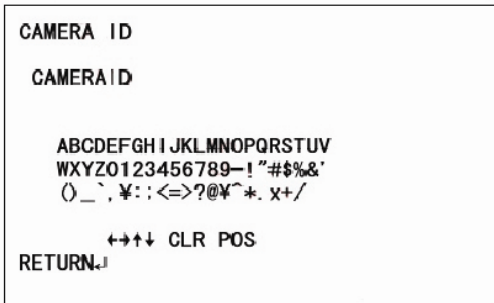

Use the joystick to navigate the cursor. Pushing centrally on the joystick will allow selection of that character.

The arrows at the bottom allow you to move the cursor without changing the character.

### **CLR**

Inserts a space

### **POS**

Allows you adjust the location of the camera ID title display. (if you move too much right side or down, it might lose ID on the screen)

## **LANGUAGE**

---

**LANGUAGE** select between:

English, Japanese, German, French, Russian, Portuguese & Spanish.

## **CAMERA RESET**

---

**CAMERA RESET** - Returns the camera to the factory default settings.

## **SAVE ALL**

---

**SAVE ALL** - Saves all the changes made in the menu.

## **EXIT**

---

**EXIT** – Exits the menu and does not save changes made.

# AUTO WHITE DEFECT

---

Push the left button for 5 seconds and enter Auto white defect menu.  
Cover the lens and Enter for starting.

If white defects are over 65pcs, the camera is faulty and auto defect is useless.

Over 70°C Auto white defect can't be activated.

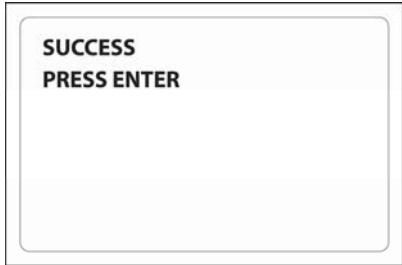
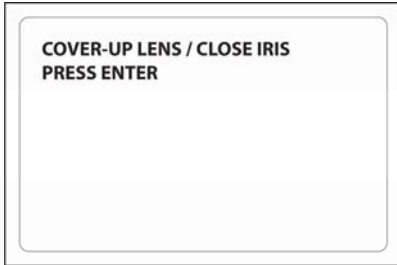

# DC IRIS LENS

The lens is not supplied with this camera. Purchase a lens suitable for your requirements. These cameras accept both C-and CS-mount type lens.

<Notes >

- For using main functions it is recommended to use Auto Iris Lens with DC type.
- If the lens is marked with fingerprints other marks, the image quality might be poor.
- It is recommended to use a high quality lens to improve the image quality under low illumination.

## <INSTALLING AUTO IRIS LENS>

1. Remove the cover from the iris lens plug supplied, and solder the lens cable to the plug as shown below.

- Video type:
  - Pin 1 --- Red (Power source)
  - Pin 2 --- N.C
  - Pin 3 --- White (Video signal)
  - Pin 4 --- Black (GND)
- DC type:
  - Pin 1 --- Damping-
  - Pin 2 --- Damping+
  - Pin 3 --- Drive+
  - Pin 4 --- Drive-

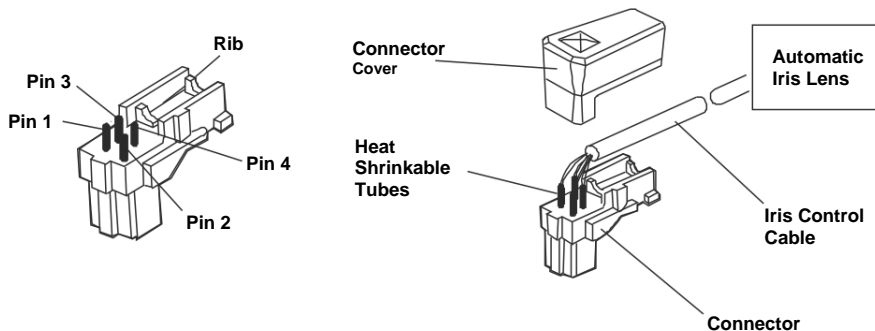

2. Remove the protective cap, and attach the lens to the camera by turning clockwise.



# SPECIFICATIONS

MODEL		NTSC	PAL	Free	
Power	Power source	DC 12V / AC 24V±10%		100-240V~50Hz ±1Hz	
	Power consumption	3.5 Watts (300mA)		4.0 Watts(60mA)	
General	Image sensor	1/3" SONY EXview HAD CCD II			
	Total pixels	1020(H) x 508(V)	1020(H) x 596(V)		
	Effective pixels	976(H)x494(V)	976(H)x582(V)		
	Scanning system	2:1 Interlace			
	Scanning frequency	15.734KHz(H) x 59.94Hz(V)	15.625KHz(H) x 50Hz(V)		
	Sync. system	Internal			
	Electronic Shutter	1/60 ~ 1/10,000 sec	1/50 ~ 1/10,000 sec		
	Resolution	700TVL			
	Min. illumination	0.15lux			
	Video output	1.0Vp-p (75 ohm, composite)			
	S/N ratio	More than 50dB (AGC OFF)			
	Camera Control	Internal OSD Key			
	F U N C T I O N	ATR (Adaptive Tone Reproduction)	LUMINANCE(L/M/H), CONTRAST(L/LM/M/MH/H)		
		Backlight	OFF / BLC / HLC		
		Day & Night	Color / BW / Auto		
		MD (Motion Detection)	"On (4 areas) / Off Adjustable Size & Sensitivity"		
		PM (Privacy Masking)	0 ~ 4 zone		
		WB (White Balance)	ATW/ PUSH/ USER1/ USER2/ ANYICR/ MANUAL/ PUSH LOCK		
		AGC (Auto Gain Control)	On / Off		
		Exposure	Auto Iris / Auto Iris + Electronic Shutter		
		Brightness	0 ~ 255 steps		
		Contrast	0 ~ 255 steps		
		Sharpness	0 ~ 255 steps		
HUE		0 ~ 255 steps			
Gain		0 ~ 255 steps			
NR(Noise Reduction)		OFF / Y / C / Y, C			
Mirror		ON/OFF			
Connector & etc.		Power input	2-pin terminal block		Power Cord
	Video output	BNC connector			
	Auto iris output	4-Pin Mini Din jack (standard connection)			
	Lens Mount	C/CS Mount (Selected through back focus)			
	Operating temperature	-10°C ~ +50 °C			
	Operating humidity	0~96% (non-condensing)			
	External dimension	88(W) x 275(H) x 88(D)mm			
	Weight	240g		440g	

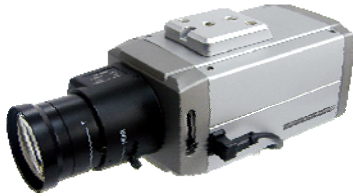

**DNR Super High Resolution  
Day & Night Color Camera**

