

UNI EN ISO 9001:2008  
CSQ  
CERT. N° 9105 BNVD



UNI EN ISO 14001:2004  
CSQ  
ec  
CERT. N° 9191 BNVN



## USE AND MAINTENANCE MANUAL

*Translations of the Original Instructions*

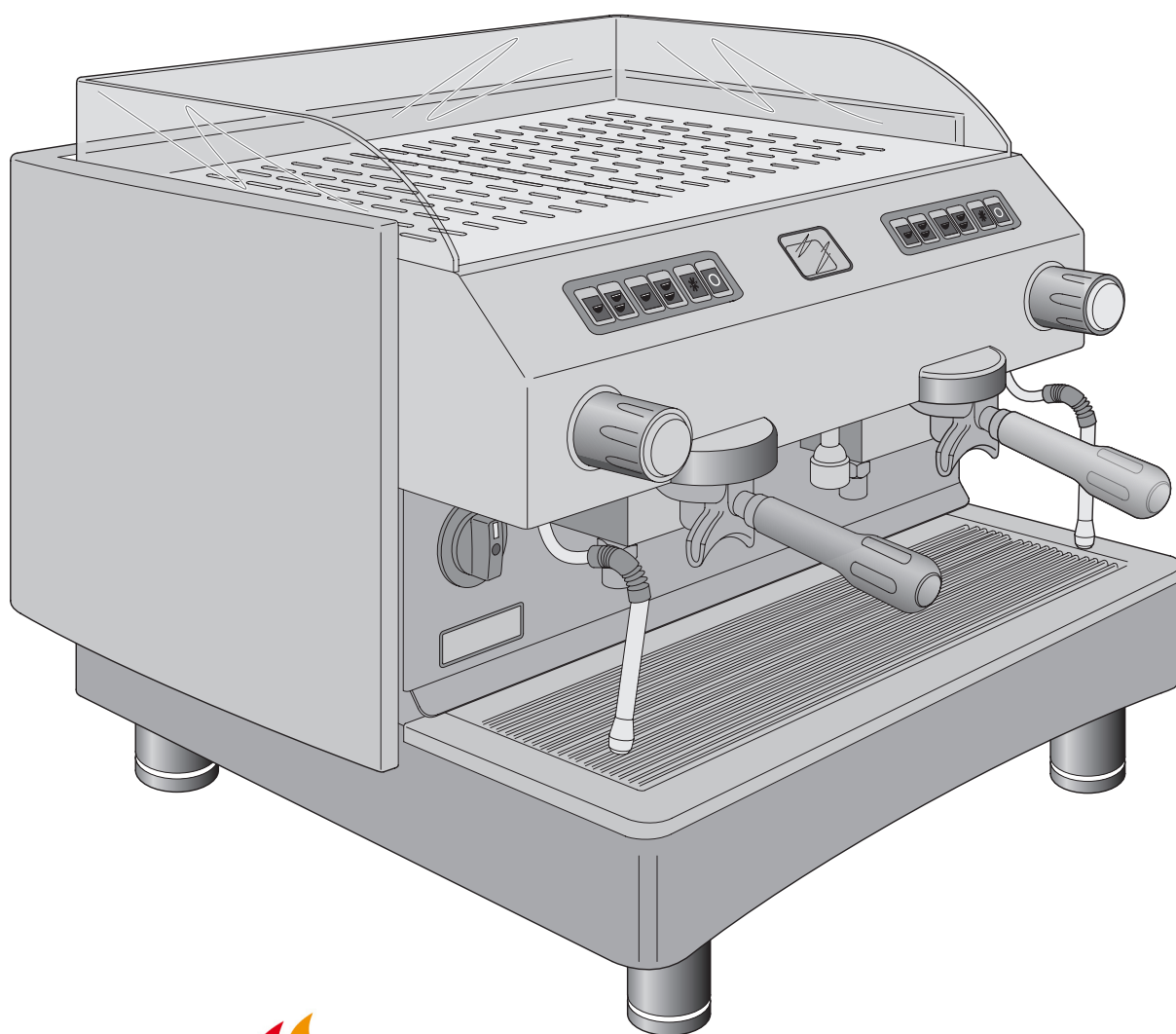

**sara**  **BVM 346**  
**bianchi**horeca.com

## ITALIANO

Maggiori informazioni si possono scaricare dal nuovo portale di Bianchi Vending Group all'indirizzo: <http://webshop.bianchivending.com>. Per accedervi è però necessario essere in possesso di **USERNAME** e **PASSWORD** che possono essere richiesti direttamente a Bianchi Vending all'indirizzo: [info@bianchivending.com](mailto:info@bianchivending.com) solamente se si è in possesso di un codice cliente.

I moduli di **PRIMA INSTALLAZIONE** e **RICAMBI IN GARANZIA** possono essere invece scaricati dal sito istituzionale: <https://www.bianchivending.com> sotto la voce "Quick links - Garanzia".

## ENGLISH

For further information, please log on to Bianchi Vending Group's new portal <http://webshop.bianchivending.com>, which can be accessed via a **USERNAME** and **PASSWORD** that can be obtained directly from Bianchi Vending at [info@bianchivending.com](mailto:info@bianchivending.com) only if you possess a customer code.

The **FIRST INSTALLATION** and **SPARE PARTS UNDER WARRANTY** forms can be downloaded from <https://www.bianchivending.com> - Quick links - Warranty.

## ESPAÑOL

Otras informaciones se pueden descargar en el nuevo portal de Bianchi Vending Group en la dirección <http://webshop.bianchivending.com>. Para acceder es necesario poseer un **NOMBRE DE USUARIO** y una **CONTRASEÑA** que pueden pedirse directamente a Bianchi Vending en la dirección: [info@bianchivending.com](mailto:info@bianchivending.com) solamente si se tiene un código cliente.

Los módulos de **PRIMERA INSTALACIÓN** y **REPUESTOS EN GARANTÍA** se pueden descargar desde la web institucional: <https://www.bianchivending.com> con la opción "Quick links - Garantía".

## FRANÇAIS

Pour tout renseignement complémentaire, téléchargez les informations sur le nouveau portail Bianchi Vending Group à l'adresse <http://webshop.bianchivending.com>. Pour y accéder, vous avez cependant besoin d'avoir un **IDENTIFIANT** et un **MOT DE PASSE**, que vous devez demander directement à Bianchi Vending à l'adresse de courrier électronique [info@bianchivending.com](mailto:info@bianchivending.com) uniquement si vous possédez un code client.

Vous pouvez télécharger les formulaires de **PREMIÈRE INSTALLATION** et de **PIÈCES DÉTACHÉES SOUS GARANTIE** sur le site institutionnel: <https://www.bianchi vending.com> à la rubrique « Liens rapides - Garantie ».

## DEUTSCH

Nähere Informationen können vom neuen Portal von Bianchi Vending Group unter der Adresse <http://webshop.bianchivending.com> heruntergeladen werden. Für den Zugriff muss der Benutzer in Besitz einer **USERNAME** und eines **PASSWORDS** sein, die direkt bei Bianchi Vending unter der Adresse: [info@bianchivending.com](mailto:info@bianchivending.com) nur mit der Eingabe einer eigenen Kundennummer eingeholt werden können.

Die Formulare der **ERSTEN INSTALLATION** und **ERSATZTEILE IN GARANTIE** können dagegen auf der institutionellen Webseite <https://www.bianchivending.com> unter "Quick links - Garanzia" heruntergeladen werden.

## PORTUGUÊS

Maiores informações podem ser baixadas do novo portal da Bianchi Vending Group no endereço: <http://webshop.bianchivending.com>. Porém, para acessar ao mesmo é necessário possuir um **USERNAME** e **SENHA** que podem ser solicitados diretamente à Bianchi Vending no endereço: [info@bianchivending.com](mailto:info@bianchivending.com) somente caso se possua um código cliente.

Por outro lado, os módulos de **PRIMEIRA INSTALAÇÃO** e **PEÇAS DE REPOSIÇÃO EM GARANTIA** podem ser baixados do site institucional:

<https://www.bianchivending.com> no ponto "Quick links - Garantia".

## DECLARATION OF CONFORMITY

**BIANCHI VENDING GROUP S.p.A.**

Corso Africa, 9 - 24040 Zingonia di VERDELLINO (BG) Italia

Declares under its own responsibility that the family of Professional Machines:

Brand: **BIANCHI VENDING**

Manufacturer: **BIANCHI VENDING GROUP S.p.A.**

Mod.: **BVM 346**

Commercial name: **SARA**

**Coffee Machines for professional use**

TECHNICAL DOCUMENTATION guarded at Technical Office BVG Headquarters. - Construction Year: **2013** -

Is in compliance with the Basic Requirements included in the following Directives:

**1) LOW VOLTAGE – 2006/95/EC** (on the harmonisation of the laws of Member States relating to electrical equipment designed for use within certain voltage limits) –**LV**–.

**2) MACHINERY DIRECTIVE 2006/42/EC** and amendments and additions implemented in Italy by D.LGS 17/2010 – Machinery Dir.

**3) ELECTROMAGNETIC COMPATIBILITY – 2004/108/EC** (on the approximation of the laws of the Member States relating to electromagnetic compatibility) –**EMC**–.

**4) REG. (EC) 1935/2004** on materials and articles intended to come into contact with food.

**REG. (EC) 1895/2005** on the restriction of use of certain epoxy derivatives in materials and articles intended to come into contact with food.

**DIR. 2002/72 EC** relating to plastic materials and articles intended to come into contact with foodstuffs.

The tests/checks were performed in accordance with the current European Harmonised Standards:

**1) SAFETY (Low Voltage - Machinery Directive):**

EN 60335-1:2002 + A1:2004 + A11:2004 + A2:2006 + A12:2006 + A13:2008 + A14:2010 + A15:2011

(Safety of household and similar electrical appliances – General requirements).

EN 60335-2-75:2004 + A1:2005 + A11:2006 + A2:2008 + A12:2010 (Particular requirements for commercial dispensing appliances and vending machines).

EN ISO 11201:2010 + EN ISO 3744:2009 (Measurement of acoustic noise). Sound Pressure level: LpA < 70 dB(A).

**2) ELECTROMAGNETIC COMPATIBILITY (EMC):**

EN 55014-1:2006 + A1:2009 (Limits and methods of measurement of radio disturbance characteristics of household appliances, similar engine or heating appliances, of tools and similar electrical apparatus).

EN 55014-2:1997 + A1:2001 + A2:2008 (Immunity requirements for household appliances, tools and similar electrical apparatus).

EN 61000-3-2:2006 + A1:2009 + A2:2009 (Limits for harmonic current emissions).

EN 61000-3-3:2008 (Limitation of voltage fluctuations and flicker in low-voltage supply systems for equipment with rated current ≤ 16 A).

EN 62233:2008 (Measurement methods for electromagnetic fields of household appliances and similar apparatus with regard to human exposure).

**3) SUITABILITY OF MATERIALS FOR CONTACT WITH FOOD STUFFS**

Selected tests for the "Suitability for contact with foodstuffs" as required by Italian law:

Min. Dec. 21-03-1973 and following amendments ⇒ Decree 4<sup>th</sup> May 2006 no. 227, and by transposition of European Directives: 82/711/CEE, 85/572/CEE, 93/8/CEE, 97/48/CE, 2002/72/EC, 2004/13/EC, 2004/19/EC, 2005/79/EC. Reg. EC no. 1935/04 and Reg. EC no. 1895/2005.

Zingonia di Verdellino (BG), January 2013

Chief Executive Officer

Luca Parolari

### INFORMATION TO THE USERS

Under Legislative Decree 25 September 2007, no.185 and art. 13, Legislative Decree 25 July 2005, no.151 "Implementation of Directives **2002/95/EC**, **2002/96/EC** and **2003/108/EC**, regarding the reduction of use of hazardous substances in electrical and electronic equipment as well as waste disposal".



The barred waste container symbol on the equipment means that the product, at the end of its service life, must be disposed of separately from the other types of waste.

The user must therefore convey the equipment, at the end of its service life, to the appropriate separate collection centres for electronic/electrotechnical waste products or return it to the dealer when purchasing a new equivalent equipment.

The appropriate separate collection and the following sending of the used equipment to recycling, treatment and eco-friendly disposal will help avoid negative effects on the environment as well as on health along with an easier recycling of the materials forming the equipment.

Any unauthorized disposal of the product by the user will imply the enforcement of the administrative sanctions as set out in Legislative Decree no. 22/1997 (article 50 and following articles, Legislative Decree no. 22/1997).

## DECLARATION OF CONFORMITY

**BIANCHI VENDING GROUP S.p.A.**

Corso Africa, 9 - 24040 Zingonia di VERDELLINO (BG) Italia  
declares under its own responsibility that the product families:

**Semi/Automatic Hot & Cold Beverages Dispenser  
Automatic Vending Machines with Spirals for Cold Products  
Coffee Machines for professional use**

Brand: **BIANCHI VENDING**

Manufacture: **BIANCHI VENDING GROUP S.p.A.**

Construction Year: **2013**

Is in compliance with the Directive: **RoHS 2**

RoHS 2 - Directive 2011/65/UE of the European Parliament and of the Council of 8 June 2011, on the restriction of the use of certain hazardous substances in electrical and electronic equipment (EEE).

It also States that by January 3, 2013, any product BIANCHI VENDING GROUP S.p.A. entered in the **European Economic Area** (UE+Iceland-Norway + Liechtenstein) is in compliance with RoHS directive 2, therefore does not contain substances with concentrations exceeding the limits listed below (\*):

- Lead [Pb] 0,1%
- Mercury [Hg] 0,1%
- Cadmium [Cd] 0,1%
- Hexavalent chromium [Cr(VI)] 0,1%
- Polybrominated biphenyls [PBB] 0,1%
- Polybrominated diphenyl ethers [PBDE] 0,1%

(\* ) ANNEX II - Restricted substances referred to in Article 4(1) end maximum concentration vales tolerated by weight in homogeneous materials.

Zingonia di Verdellino (BG), January 2013

Chief Executive Officer

Luca Parolari

BEFORE USING THE MACHINE, READ THIS MANUAL CAREFULLY FOR ITS CORRECT USE IN ACCORDANCE WITH THE CURRENT safety STANDARDS.



**ATTENTION:** Important safety indications



**READ** the instruction manual machine carefully before using the machine



For any service or maintenance **switch off** the machine



**ATTENTION:** machine switched on



**ATTENTION:** hot parts in contact!



PE

Earthing indication



## **IMPORTANT NOTICES**

### **OPERATOR**



By "operator" we mean the person assigned to machine use and operation and to coffee refilling tasks. The operator must furthermore take care of all the necessary machine cleaning operations. In the event of machine breakdowns, the operator is required to contact the installation and service technicians accordingly.

### **INSTALLATION TECHNICIAN**



The installation technician is defined as the person responsible for the installation of the coffee machine, the starting up operations and the function settings. Each regulation operation is the exclusive responsibility of the installation technician who also holds the programming access password.

## INDEX

### 1.0 INTRODUCTION

- 1.1 Directions and instructions for operators
- 1.2 General directions and instructions

### 2.0 DESCRIPTION OF THE MACHINES

### 3.0 TECHNICAL SPECIFICATIONS

- 3.1 Machine dimensions and weights
- 3.2 Items on issue with the machine
- 3.3 Mechanical safety devices
- 3.4 Electrical safety devices
- 3.5 Environmental noise
- 3.6 Vibrations
- 3.7 Machine functional specifications and make up

### 4. TRANSPORT

- 4.1 Packing
- 4.2 Inspection on delivery

### 5. INSTALLATION

- 5.1 Utilities to be provided by the customer
  - 5.1.1. Power supply
  - 5.1.2. Water mains supply
- 5.2 Machine positioning

### 6. COMMISSIONING

- 6.1 Machine control commands and devices
- 6.2 Machine start-up

### 7. OPERATION

- 7.1 How to make coffee
- 7.2 How to make cappuccino
- 7.3 How to heat up a drink
- 7.4 How to make teas and infusions

### 8. DOSAGE ADJUSTMENT AND CALIBRATION (for versions equipped with this function)

- 8.1 Electronic dosage machine versions
  - 8.1.1 Dosage adjustment

### 9. MAINTENANCE

- 9.1 Daily maintenance
- 9.2 Weekly maintenance
  - 9.2.1 Cleaning the dispensing groups
  - 9.2.2 Cleaning the filters
  - 9.2.1 Cleaning the collection tray
- 9.3 Periodic maintenance tasks
  - 9.3.1 Water replacement and total emptying out of the boiler
  - 9.3.2 Regeneration of the water treatment units

### 10. PUTTING THE MACHINE OUT OF SERVICE

- 10.1 Putting the machine out of service temporarily
- 10.2 Putting the machine out of service definitely

### 11. TROUBLE SHOOTING

## 1.0 INTRODUCTION



### 1.1 Directions and instructions for operators

This coffee brewing machine has been engineered and constructed in full compliance with all the laws and regulations currently in force on safety issues. It is deemed as being safe to machine operators that accurately comply with all the directions and instructions provided in this Manual.

*The user must not under any circumstances remove the guards that require a tool for removal.*

Some maintenance operations (to be done solely by specialized technicians and indicated in this manual with a special symbol) require that specific safety protections of the machine must be switched off .

In accordance with the current safety regulations, certain operations are the exclusive responsibility of the installation technician, and the ordinary maintenance technician may have access to specific operations on with specific authorization.

The acquaintance and absolute respect, from a technical point of view, of the safety instructions and of the danger notices contained in this manual, are fundamental for the execution, in conditions of minimum risk, for the installation, use and maintenance of this machine.

### 1.2 General Instructions

*Knowledge of the information and instructions contained in the present manual is essential for a correct use of the coffee machine on the part of the user.*



*Interventions by the user on the coffee machine are allowed only if they are of his competence and if he has been duly trained.*

*The installation technician must be fully acquainted with all the mechanisms necessary for the correct operation of the coffee machine.*

- *It is the buyer's responsibility to ascertain that the users have been trained and are informed and regulations indicated in the technical documentation supplied.*

*Despite the full observance of the safety regulations by the constructor, those who operate on the coffee machine must be fully aware of the potential risks involved in operations on the machine.*

- *This instruction manual constitutes an integral part of the coffee machine and as such, it must be always be on hand in the vicinity of the machine for easy consultation by the various machine operators, right until the machine is actually stripped and scrapped.*

- *In case of loss or damage of the present manual it is possible receive a new copy making application to the manufacturer, with prior indication of the data registered on machines' serial number.*

- *Modifications to the machine not previously agreed on with the construction company and undertaken by the installation technician are considered to be under his entire responsibility.*

*All the operations necessary to maintain the machine's efficiency, before and during it's use are at the users charge.*

- *Any manipulations or modifications made to the coffee machine that are not previously authorized by the manufacturer, relieve the latter from any responsibility for damages deriving from, and will automatically result in the cancellation of the machine guarantee terms.*

- *This manual reflects the status at the moment of the emission of the coffee machine on the market; possible modifications, upgrading, adaptmets that are done the machine and that are subsequently commercialized do not oblige **Bianchi Vending Group Spa** neither to intervene on the machine previously supplied, nor, neither to update the relative technical documentation supplied together with the machine.*

- It is however **Bianchi Vending Group's** faculty, when deemed opportune and for valid motives, to adjourn the manuals already present on the market, sending to their customers adjournment sheets that must be kept in the original manual.

Possible technical problems that could occur are easily resolvable consulting this manual ; For further information, contact the distributor from whom the machine has been purchased, or contact Bianchi Vending Group's Technical Service at the following numbers:

**+039. 035.45.02.111**  
**fax +039. 035.883.304**

Whenever the machine servicing facilities are contacted, it is necessary to quote the data on the serial number rating plate. Bianchi Vending Group S.p.A. hereby declines each and every liability whatsoever arising for damages to persons and/or objects subsequent to failure to observe the following directions and warnings during installation and/or operation of the coffee machine:

- The machine must be exclusively positioned in places where use is strictly reserved to appropriately trained personnel.
- Potentially hazardous machine packing material (plastic bags, expanded polystyrene, cardboards staples and nails, etc) must strictly not be left on hand for access by children.
- Prior to connecting up the machine, check to ensure that the rating plate data is compliant with the power mains. The use of adapters, multiple socket strips and/or extensions is strictly prohibited.
- In case of uncertainty, have the power supply system inspected by qualified personnel. The system must comply with all the relative provisions and regulations in force, amongst which:
  - machine grounding;
  - conductor sectioning to be appropriately sufficient for electrical input;
  - circuit breaker device, suited to overload cat. 3.
- Check to ensure that the mains voltage does not have a displacement greater than 6%.
- Check to ensure that the pressure is comprised between 0.5 and 5 bar.
- The machine is not intended for installation in industrial kitchens, private consumer kitchens and the likes.
- The machine is not intended for outdoor installation or for installation in places subject to water sprays and/or water jets.
- Position the machine on a waterproof surface (i.e. laminate, steel, ceramic tiling, etc.) and far away from heat sources (ovens, cookers, chimneys, etc.), in sites where the ambient temperature will not drop below 5°C.
- Position the machine onto a support surface so that the cup heater is located at a height 150 cm above floor level.
- Do not expose the machine to bad weather or install it in environments with excess ambient humidity.
- Do not in any way obstruct the suction or dissipation grids and particularly do not cover the cup heater surface with dishcloths or other objects.
- When packed, the machine must be stored in sufficiently dry storage facilities with temperatures not less than 5°C. It is possible to stack only up to three packages of the same machine on top of one another. Avoid placing any other types of heavy packages on top of the machine package.
- To ensure standard operations, the appliance must be installed in sites where the environmental temperature is comprised between a minimum +5°C and a maximum +50°C temperature and where the absolute humidity is not in excess of 75%.
- Do not position the appliance in the vicinity of inflammable objects and always keep a safety distance of at least 30 cm.
- Removal of mechanical, electrical and/or heat safety guards and protections is strictly prohibited.
- In the event of emergencies such as conflagration and fire, out of the order noises and heating, etc. immediately unplug the machine from the power mains, close any water and/or gas supply taps and faucets as the case may be.
- In the event that during handling and transport operations the machine where to transit in ambient temperatures close to or under 0°C, the technician is required to subsequently empty out the hydraulic circuit.

The standard factory conditions provide for machine delivery without water in the internal circuits.

- To ensure faultless machine operations, use only accessories and spares as authorised by the manufacturer.
- The coffee machines have been engineered and constructed for the brewing of espresso coffee and other hot drinks. Any other use is considered as improper and hazardous machine use.
- The machines are intended exclusively for foodstuff preparation purposes. The use/introduction of liquids and/or other substances that may generate hazards and/or contaminate the dispensers.

*Bianchi Vending Group S.p.A can in no way whatsoever be held liable to compensation for any possible damages arising due to forced interruptions of machine dispensing operations caused by breakdowns and failures.*

**The operator must:**

- Not come into contact with any hot machine parts and/or with the dispensing area.
- Not place containers holding liquids onto the machine.
- Not undertake maintenance and/or handling operations with the machine plug still in the power mains or when not cooled down.
- Not wash the machine with direct, pressurised water jets.
- Neither partially nor entirely submerge the machine in water.
- Not use the machine if the electric power supply cable looks as though it is damaged.
- Not touch the machine with wet or moist hands and/or feet.
- Not use the machine if minors are present in the immediate vicinity thereof.
- Not allow the machine to be used by minors or disabled individuals.
- Not obstruct the heat suction or dissipation grids with dishcloths or other objects.
- Not use the machine if it is in any way wet or moist, unless it is the machine's dispensing area.

**The manufacturer hereby declines each and every liability for damages whatsoever arising to persons and/or things due to improper, wrong or unreasonable use of any one of the machines by non-professional operators.**

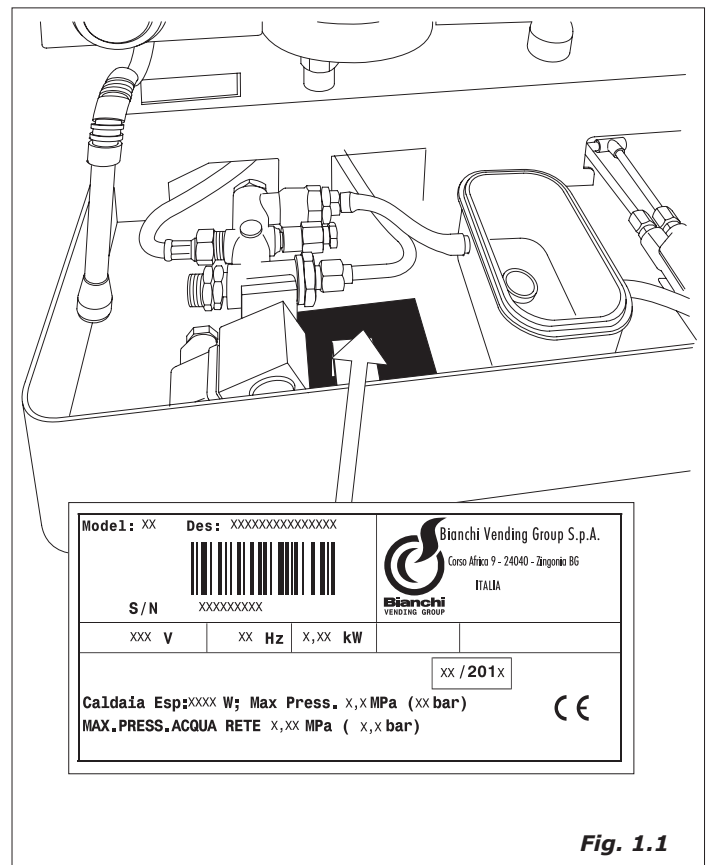

**Fig. 1.1**

## 2. DESCRIPTION OF THE MACHINES

The **Sara Espresso** coffee machine series have been engineered and constructed for the brewing of espresso coffee and other hot drinks. Any other use is intended as improper or dangerous.

**The manufacturer hereby declines each and every liability for damages whatsoever arising to persons and/or things due to improper, wrong or unreasonable use of any one of the machines.**

The machine operator must observe all the use and maintenance instructions in this manual, at all times. Should any doubts on operation or anomalies arise, stop the machine, do not attempt repairs or direct interventions on the machine and immediately contact the service facilities accordingly.

The series of **Sara Espresso** coffee machines is available either in electronically controlled dispensing versions with programmable cup dosage, or in continuous dispensing versions (i.e. with push-button regulation).

The dispensing group is heat set and stabilised to ensure optimised utilization of all the noble coffee components. An electronic device warrants for optimised hot water auto-levelling in the boiler unit. Water and steam dispensing is provided via 3 high-performance multi-direction spouts that allow for the preparation of cappuccinos and other hot drinks.

Said technical solutions ensure that energy wastes are prevented thereby safeguarding the machine from dangerous thermal shocks.

Water as necessary is tapped in directly from the water mains and is pressurised via a sealed or maintenance free volumetric pump. Water heating is provided via conductive thermal exchange in the boiler unit.

By activating the appropriate controls located on the machine's frontlet panel, optimally pressurised and heated water is delivered to the dispensers.

The machine is provided with a steel structural framework, onto which all its mechanical and electric components are fixed.

The machine bodywork is in stainless steel and Baydur® to guarantee optimised protection and safety combined with unique designing.

## 3.0 TECHNICAL SPECIFICATIONS

### 3.1 Machine dimensions and weights

DIMENSIONS AND WEIGHTS	SARA ESPR. 2 GROUP VERSION
Length [mm]	700
Depth [mm]	540
Height [mm]	500
Weight [kg]	70
Boiler capacity [litres]	12
<b>PACKING</b>	
Volume [cm <sup>3</sup> ]	340
Dimensions LxDxH [mm]	620x830x660
Gross Weight [kg]	74
Power supply voltage	230V/400V
Power supply frequency	50Hz/60Hz
Power input	3,22/3,22 kW
Steam boiler rated pressure	1,4 bar
Heat exchanger rated pressure	12 bar

### 3.2 Items on issue with the machine

	SARA ESPR. 2 GROUP VERSION
1 dose filter basket	N°1
2 dose filter basket	N°2
1 dose filter	N°1
2 dose filter	N°2
Blind filter	N°2
Inlet tube 1.7 m long	N°1
Discharge tube 1.5 m long	N°1
Instruction manual	N°1
Wiring diagrams	N°1

### 3.3 Mechanical safety devices

- Complete safety and protection panelling on all hot machine parts and on the hot water and steam generator.
- Work surface with grid and liquid collection tray.
- Expansion valve on the hydraulic system and safety valve on the heater.
- Non-return valve on the hydraulic system to avoid refluxes into the water mains.

### 3.4 Electrical safety devices

- Low-voltage keypad controls
- Thermal overload protection on the pump motor
- Thermal overload protection on the resistance elements

### 3.5 Acoustic noise

Sound pressure levels amounting to 70 db(A) are not normally exceeded on the machine operation site.

### 3.6 Vibrations

The machines are equipped with vibration-proof rubber feet. In standard working conditions, the machines do not generate dangerous vibrations, neither for the operator nor for the environment.

### 3.7 Machine functional specifications and make up

The overall Sara Espresso range is available in the following configuration versions:

Semi-automatic version:

- With double Steam dispenser nozzle and hot water dispenser pipe (GROUPS 2)

Automatic version:

- With machine operation display functions.
- With double Steam dispenser nozzle and hot water dispenser pipe (GROUPS 2)

## 4. TRANSPORT

### 4.1 Packing

The machine is delivered in one single cardboard package, with internal expanded polystyrene safety padding inserts.

The packing is provided with conventional symbols to be accurately observed during package handling and storing operations.

During transport the package must be kept in a consistently vertical position.

Do not turn upside down or onto one side.

Transport carefully avoiding bumps and impacts and exposure to bad weather.

### 4.2 Inspection on delivery

Upon delivery, check to see that the machine complies exactly with the description provided on the transport documents, accessories included.

Check to see that the machine has not been subject to transport damages. If it has, immediately report the occurrence to the forwarder as well as to our customer service department.

Potentially hazardous machine packing material must strictly not be left on hand for access by children.

Do not disperse the packing material in the environment but ensure that it is accurately disposed of via appropriate packing and waste recycling facilities.

## 5. INSTALLATION

The machines are fitted with height-adjustable feet. Ensure that height is adjusted identically for all the four base feet.

The positioning support surface must be evenly levelled, dry, strong and stable, to be positioned at a height of at least 110 cm from the floor.

For correct machine operations it is not necessary to anchor it to the support surface and neither are technical devices required to limit vibrations.

It is hereby recommended that some free space is left all around the machine, to make use and maintenance operations quick and easy

Do not install the machine if it is wet or moist and wait until the machine is surely and completely dry. Prior inspections by the service personnel are anyway necessary, to warrant that the machine's electrical components are not damaged.

Make sure that enough space is left in the vicinity of the machine for positioning of the dose-grinder coffee.

In the event that the machines are equipped with a water treatment unit, said unit must be hooked up by the installation personnel in full compliance with all the existing laws and regulations in force.

In the event of installation of different water treatment units not specifically dedicated to the machine, make sure that all the relative product documentation is completely observed.

Have the installation personnel install a coffee grounds collector tray.

### 5.1 Utilities to be provided by the customer

**All the utility connection operations must be conducted by qualified personnel, in full compliance of the federal, state and/or local rules and regulations in force.**

#### 5.1.1 Power supply

The machine is supplied ready for connection to the on-site power mains according to the specifications requested upon purchasing.

Prior to connecting up the machine, check to ensure that the rating plate data is compliant with the power mains voltage data. The power supply cable, that must be wholly undamaged, must be hooked up directly into the previously prepared utility connections as per all the rules and regulation in force. The grounding and atmospheric overload discharge safety and protection systems must mandatorily be executed as per all existing laws and regulations. For connection to the power mains, implement only an up-to-standard cable, provided with a safety (grounding) conductor.

For the three-phase power supply, use a 5 conductor (3-phases + neutral + ground) connector.

For the single-phase power supply, use a 3 conductor (3-phases + neutral + ground) connector.

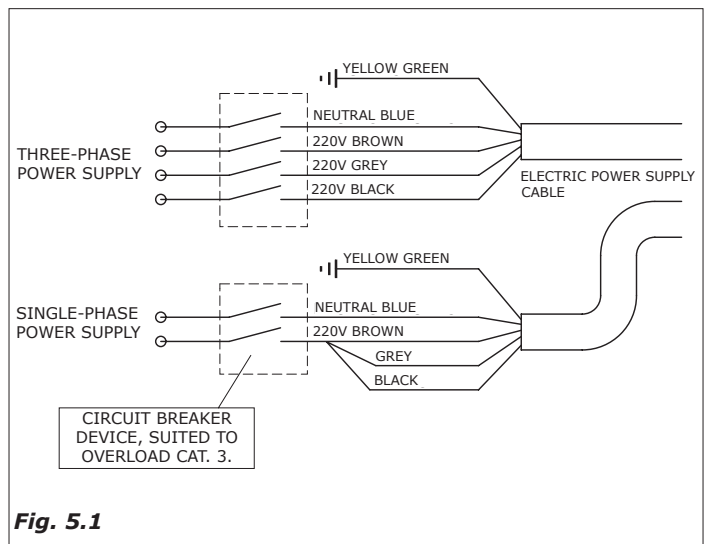

**Fig. 5.1**



In both cases, a differential switch must be arranged upstream of the power supply cable, complete with magnetic release switches compatible with the data provided on the machine rating plate. The relative contacts must be provided with an opening equal or greater than 3mm.

We hereby remind that each machine must be provided with its own, individual safety devices.

**In the event that the power supply cable is damaged, it must be replaced either by the manufacturer, by the manufacturer's technical services or by qualified personnel that is capable of preventing any possible hazards.**

### 5.1.2 Water mains supply (Fig. 5.2)

The water mains connections must be arranged to be in the vicinity of the machine.

- Liquid ground collection tank discharge tube
- Water supply tube

**Following is the correct procedure for connecting the machine up to the water mains:**

- 1 connect the reticulated tube (provided on issue in the packing) up to the water mains.
- 2 rotate the machine start-up turn-knob (Fig. 6.1, item 9) to position 1, whereupon the machine will automatically fill in water, up to the probe level

### 5.2 Machine positioning

- Position the machine unit onto the horizontal surface as arranged, then carefully adjust height via the adjustable feet. Ensure that the machine is not inclined at an angle larger than 2°.

Prior to proceeding with the connection, accurately wash out the water mains tubes:

- open the mains water tap completely and let the water run for a few minutes.
- Proceed with connecting up the inlet and outlet water connections.
- Hook up the machine to the electrical power mains.

Proceed with accurately washing out all the machine water pipes:

- Open the water mains supply tap completely.
- Switch on the main switch (item 1) and wait until the boiler fills up to set level
- Switch on the main switch (item 2) to start heating up of the water in the boiler.
- Activate all the groups so that they discharge water for about a minute. Repeat this operation twice.  
Wait until the machine has reached the required pressure level (about 40 minutes)
- Proceed with discharging steam from the steam spouts for about one minute.
- Discharge hot water from the hot water dispenser pipe for about a minute. Repeat this operation twice.
- Switch all the switches back off again.

**For optimised machine operations we recommend the use of a water treatment/lime scale eliminator unit to be connected up prior to entry of the mains water into the machine.**

**If the machine has not been dispensing for longer than 24 hours, prior to starting operations proceed with washing out all the internal components by repeating all the operations listed above.**

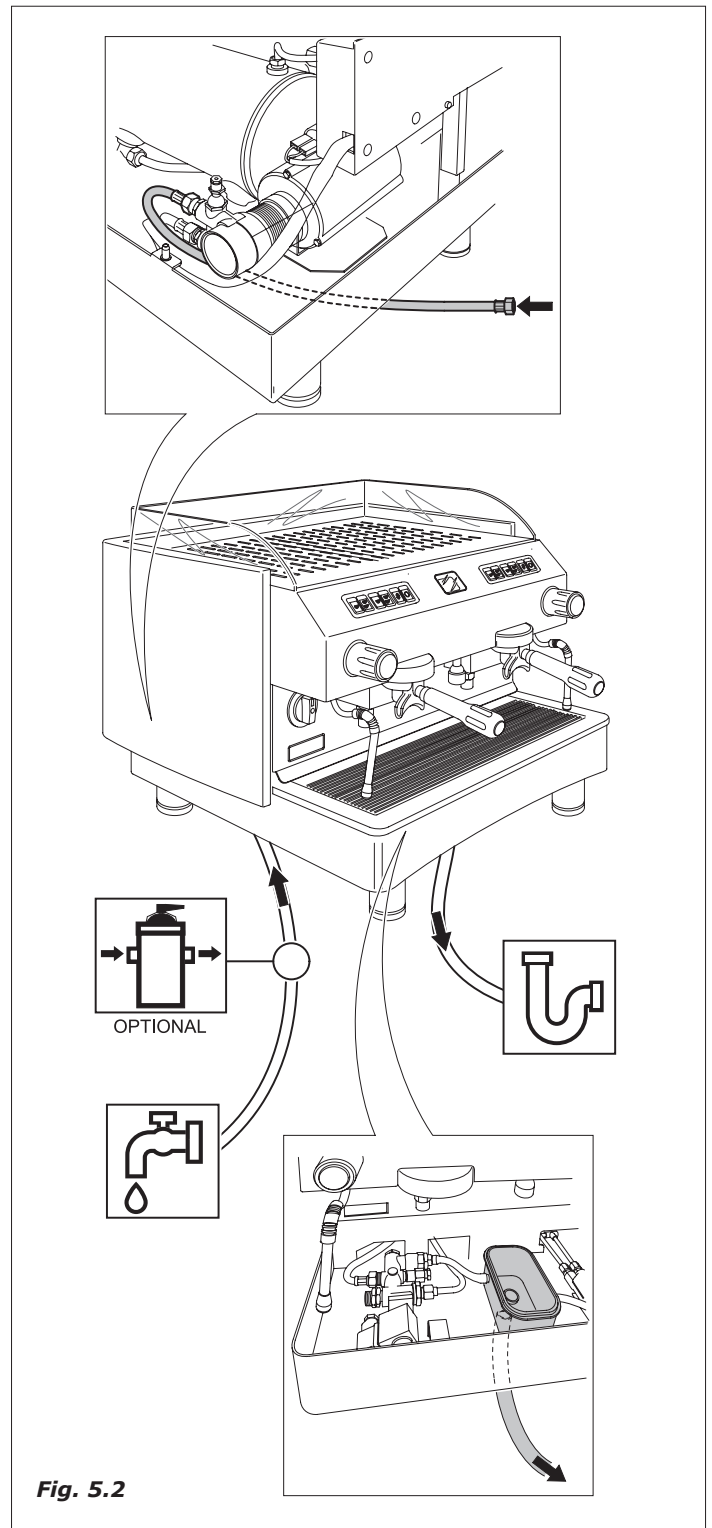

## 6. COMMISSIONING

### 6.1 Machine control commands and devices

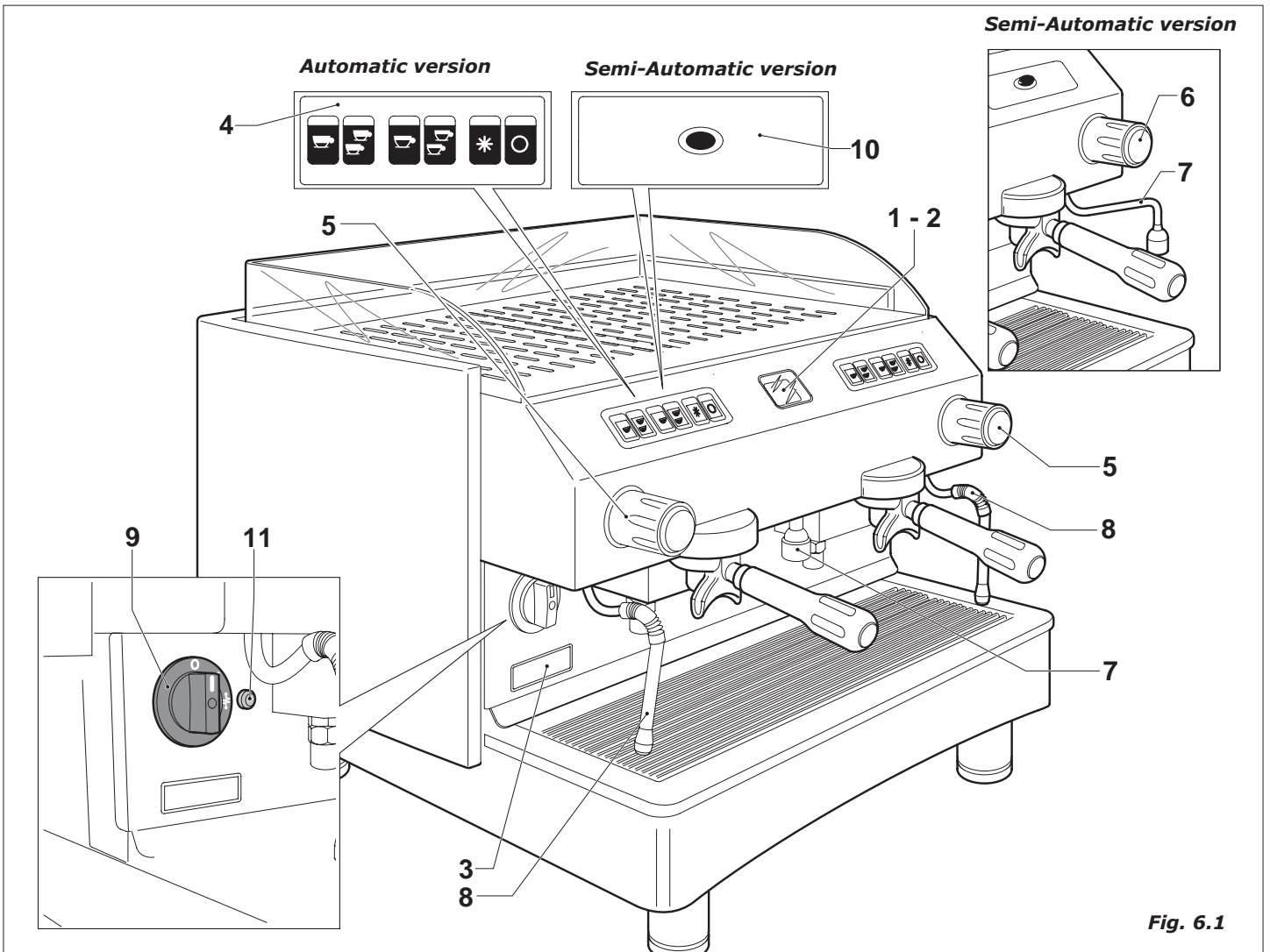

Fig. 6.1

1. Boiler pressure gauge
2. Pump pressure gauge
3. Display
4. Automatic version controls (G01)
5. Steam dispensing turn-knob
6. Water dispenser turn-knob
7. Water dispenser pipe
8. Steam dispenser nozzle
9. Selector switch
10. Semi-Automatic dispensing version controls (G03)
11. Heating element indicator light

#### Functions:

The boiler pressure gauge (1) with a 0 to 2.5 bar scale, displays the boiler pressure level :

- When the indicator is in the interval between 0 and 0.8 bar i.e. with the blue background, the machine is in its heating up stage and therefore coffee dispensing is not recommended.
- The interval comprised between 0.8 and 1.6 bar indicates that the pressure and the temperature internally to the boiler are at their ideal levels for coffee preparation.

**In the event that the pressure indicated by the pressure gauge (1) goes up to over 1.6 bar, switch the machine off immediately and contact the sales service network.**

The pump pressure gauge (2) with a 0 to -15 bar scale, displays the pump pressure level only when the pump is working.

Level display (5) indicates the level of the water in the boiler.

**The Sara Espresso coffee machine series have been equipped with a device that automatically keeps the water level in the boiler constant, by acting on the pump and on the electrovalve. If said level were not visible, switch the machine off and contact the sales service network.**

Display (3) [only for Automatic models that are equipped with one]

The multifunction display that the machine is provided with provides useful indications to the user on the machine operation status:

- Upon machine start-up and during possible boiler fill-up operations, the display unit displays the "boiler fill-up" message.
- During the machine's standby mode the display will show up the "select drink" message followed by another, customised message entered by the user.
- During the dosage programming phase, the display will show up the operations being run by the machine (section 8 refers)

#### Pushbutton dispensing version control-pushbutton.

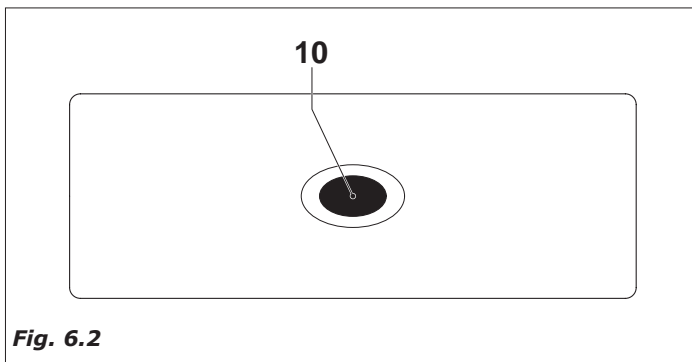

Fig. 6.2

**Key 10** coffee dispensing pushbutton

#### Multifunction keypad (only for the Automatic versions)

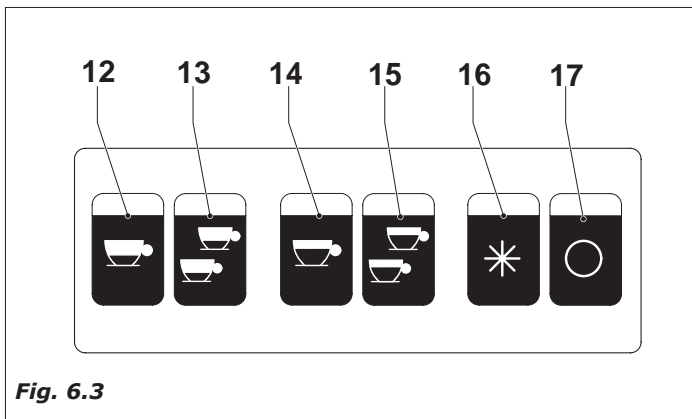

Fig. 6.3

**Key 12** dispenses the dose necessary for the preparation of one single espresso coffee

**Key 13** dispenses the dose necessary for the preparation of two espresso coffees

**Key 14** dispenses the dose necessary for the preparation of one single further diluted (i.e. weaker) espresso coffee

**Key 15** dispenses the dose necessary for the preparation of two further diluted (i.e. weaker) espresso coffees

**Key 16** activates continuous dispensing. Pressing the key for a second time, dispensing is interrupted.

**Key 17** activates water drawing from the spout (7)

## 6.2 Avvio macchina

- After having run another examination of the electric and hydraulic system connections, open the hydraulic system inlet tap.
- Position selector switch (9) on first position and wait until the electronic power pack that the machine is equipped with, executes the necessary control runs and activates the pump and electro valve for boiler fill-up

#### • **Semi-Automatic dispensing version:**

Position the empty filter basket into the dispensing group, then press pushbutton (10) and wait for the water to run out of the filter basket spout. Press the pushbutton once again to end the water dispensing cycle.

#### • **Automatic dispensing version:**

Position the empty filter basket into the dispensing group, then press pushbutton and wait for the water to run out of the filter basket spout. Press the pushbutton once again to end the water dispensing cycle.

- Position selector switch (9) onto position 2, the signal light (11) on the side will light up and the heating element will begin the heat-up phase of the water in the boiler.
- Wait for the red signal light (11) to go off, meaning that the ideal pressure in the boiler has been reached.

**During machine operations the red signal light will go on and off at irregular intervals, depending on machine use.**

- When the red signal light (11) goes off, it means that the heating element is off as well.

#### **Semi-Automatic dispensing version:**

- Position the filter basket filled with the ground coffee into the dispensing unit.
- The cup/cups under the dispensing spout
- Press the coffee dispensing pushbutton (10) that is located in the foreground
- Once the required quantity of coffee has been dispensed into the cup, press the coffee dispensing pushbutton (10) again to stop dispensing.

#### **Automatic dispensing version:**

- Position the filter basket filled with the ground coffee into the dispensing unit.
- The cup/cups under the dispensing spout
- Press key (12) for the coffee to be dispensed in one single cup. The coffee dispensing cycle will end automatically
- Press key (13) for two espresso coffees to be dispensed. The coffee dispensing cycle will end automatically
- Press key (14) for the dispensing of one further diluted (i.e. weaker) espresso coffee, in one single cup. The coffee dispensing cycle will end automatically
- Press key (15) for the dispensing of two further diluted (i.e. weaker) espresso coffee, into two cups. The coffee dispensing cycle will end automatically
- Press key (16) for the continuous coffee dispensing mode.

## 7. OPERATION

### 7.1 How to make coffee

- Detach the filter basket from the dispensing group. Turn it upside down and knock down on the filter edge area (taking care not to damage the filter) directly onto the coffee grounds collector tray to empty out all the coffee grounds.
- Use the single dose or double dose filter, as required.
- Fill up the filter with the dose of ground coffee, level the coffee out and press in lightly using the appropriate coffee presser.
- Remove any ground coffee remnants possibly still on the edge of the filter.

**Leaving ground coffee remnants on the edge of the filter may prevent the seal from closing tightly enough with subsequent loss of water and coffee grounds.**

- Hook the filter basket up onto the dispensing group firmly enough to ensure optimised tightness.
- Position the cups under the dispensing spouts. Start up the coffee dispensing cycle by pressing in either the key or the pushbutton, depending on the relative machine version.
- Once coffee dispensing is complete, leave the filter basket in the dispensing until the next dispensing cycle is run.

**During the dispensing cycles, beware of the hot machine parts i.e. particularly the coffee dispensing groups, the steam spouts and the hot water dispenser pipes. Placing one's hands under the dispensing group and spouts during machine operation is strictly prohibited.**

### 7.2 How to make cappuccino

- Make a dose of coffee in a cappuccino cup.
- Fill a tall, rather narrow container up halfway with milk.
- Position said container under the steam dispenser nozzle so that the nozzle touches the bottom of the container.
- Open the steam tap and lower the container until the steam spray skims the surface of the milk.
- Keep moving the container up and down vertically so that the nozzle simultaneously moves in and out, frothing the milk (to a creamy foam)
- Close the steam tap and pour the frothy milk into the cappuccino cup containing the coffee.

**Once done, immediately wipe off the steam dispenser nozzle using a clean, dry cloth. This will avoid milk residue crusts on the spout.**

**Warning: the nozzle will be very hot. To avoid skin burn hazards, avoid touching it directly whilst cleaning.**

### 7.3 How to heat up a drink

- Plunge the steam dispenser nozzle directly into the liquid that requires heating.
- Open the tap gradually to enable the steam to exit the spout. This will enable the steam to gradually heat the liquid up to the required temperature.
- Once the temperature has been reached, close the steam tap.

**Once done, immediately wipe off the steam dispenser nozzle using a clean, dry cloth.**

**Warning: the nozzle will be very hot. To avoid skin burn hazards, avoid touching it directly whilst cleaning.**

### 7.4 How to make teas and infusions

- Position a container under the hot water dispenser pipe and press the relative pushbutton to start drawing the hot water. Once the required quantity of hot water has been drawn, press the pushbutton again to stop drawing.
- Add the required tea flavour into the hot water.

**The use of treated water may cause the tea or infusion to have a darker appearance compared to use of standard water. If normal tea or infusion colouring is preferred, proceed with heating up non-treated water as described under previous section 7.3.**

## 8. DOSAGE ADJUSTMENT AND CALIBRATION (for versions equipped with this function)

### 8.1 Electronic dosage machine versions

The overall series of Sara Espresso coffee machines is available in automatic coffee dosage versions (Automatic). Said dose can be adjusted and customised.

#### 8.1.1 Dosage adjustment

Coffee dose adjustments are carried out by acting on the group keypads:

- Arrange the filter basket, either single or double based on the key to be adjusted, as described under the "how to make coffee" section.
- Keep the key (Fig. 8.1 – item 16) pressed in until the relative LED flashes and the versions fitted with a display show up the "PROGRAMMING SELECT WITHIN 30s" message
- The flashing led indicates that the machine is in the programming phase. Once 30 seconds have gone by the machine will automatically revert to operation mode.
- Whilst the LED is flashing, press the key relative to the dosage that must be programmed, to start dispensing.
- During the dispensing cycle, the LED corresponding to the selected program key will stay on, as will the LED on key (16). The versions fitted with a display will show up the "PROGRAMMING" message followed by the type of coffee being adjusted (espresso or "long" diluted (i.e. weaker).
- Wait for the cup dose to reach the required quantity, then press the key again to stop the dispensing cycle.
- The adjusted quantity is stored by the electronic power pack.
- repeat the operation on the remaining keys. The LEDs relative to keys that have already been programmed will stay OFF.

**For dose adjustments on machines with two or three dispensing groups, start the adjustment operations from the keyboard that is first to the left on the machine frontlet.**

**The electronic power pack will automatically store and apply the adjustments to the other machine keypads.**

**If adjustment of the groups relative to the second and/or third keyboard is also required, start the procedure all over again from the beginning.**

Fig. 8.1

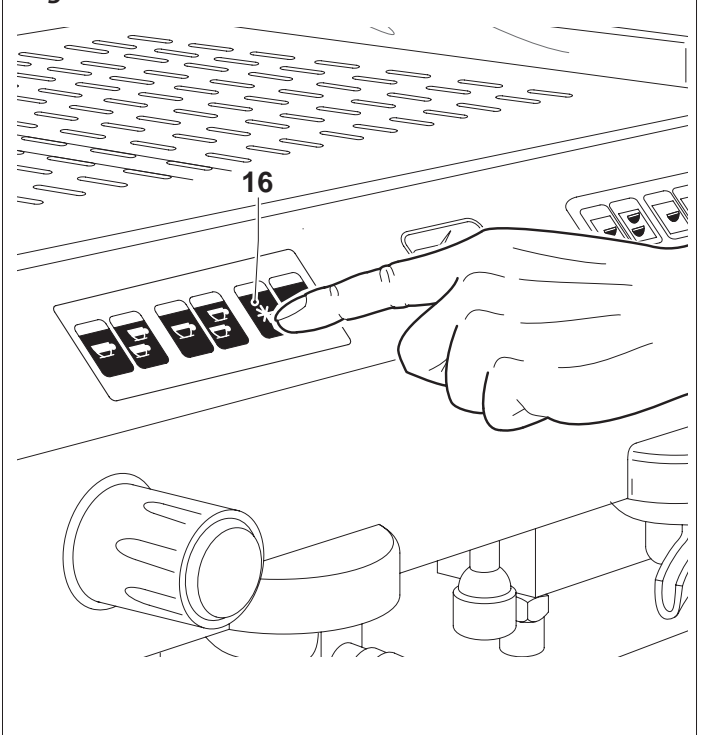

## 9. MAINTENANCE

**Unless otherwise specified, all maintenance operations must be carried out when the machine is totally powered down to OFF, it has cooled down and the mains socket is unplugged. Use of metal, abrasive tools and solvents is not recommended for machine cleaning operations:**

**they could all cause damages.**

**Where indicated, use specific detergents for coffee machines that are available on sale in the specialised technical service centres.**

### 9.1 Daily maintenance

For cleaning operations use cloths or sponges that will not release fibres or threads.

- Clean the bodywork accurately and, on the stainless steel parts, rub in the direction of the satin finish.
- Clean the steam and the hot water dispenser pipes. Check to see that the spout diffuser nozzles are not clogged or partially clogged with crusts and residues. If a crust removal operation is necessary, be very careful not to deform or damage the relative sprayer.
- Remove the filter baskets from the machine then remove the filters and proceed with removing any coffee encrustations. To remove grease deposits rinse out the filters and filter baskets using hot water.

### 9.2 Weekly maintenance

#### 9.2.1 Cleaning the dispensing groups

This operation must be conducted whilst the machine is operative and under pressure.

- Place the blind filter on issue with the machine into the filter basket. Add in a spoon of specific coffee machine detergent, then reassemble the filter basket back into the group to be cleaned.
- Activate the coffee dispensing start command on the group for about 30 seconds.  
In the Automatic version, once the filter basket is assembled back on again, press keyboard keys 12 and 16 simultaneously. The machine will automatically run five wash cycles.
- Start up and stop the dispensing cycles for the number of times required, until clean, clear water flows out of the group discharge.
- Remove the filter basket, remove the blind filter and insert a normal filter. Reassemble the filter basket back on and activate the dispensing cycle for as many times as required to ensure sufficient rinsing.
- Make a coffee to eliminate any possible unpleasant tastes.

#### 9.2.2 Cleaning the filters

- Prepare a cleaning solution using hot boiling water plus a packet of the specific coffee machine powder detergent, in a container that is not in aluminium or iron.
- Remove the filters and soak them together with the filter baskets in said solution for at least 20 minutes (if possible, all-night soaking is preferable).
- remove the filters and the filter baskets from the detergent solution and rinse them thoroughly under plenty of running water.

#### 9.2.1 Cleaning the collection tray

- Remove the cup carrier grid from the tray and clean if necessary.
- Remove the discharge tray and clean it to remove any possible encrustations and/or coffee grounds residues.

### 9.3 Periodic maintenance tasks

#### 9.3.1 Water replacement and total emptying out of the boiler

This operation must be conducted by the technical service personnel.

- Power the machine down to OFF and wait until there is no more pressure inside the boiler (i.e. the pressure gauge must be on "0")
- Remove the safety cover cap by unscrewing it at the base using an adjustable spanner (size 21).
- The water in the boiler will be emptied out.
- Arrange for a container having at least a 6/7 litre capacity for water collection.
- Reassemble the safety valve back on again.
- Proceed with filling the boiler back up again.

#### 9.3.2 Regeneration of the water treatment units

For the regeneration of the water treatment units, please consult the relative user's manual and follow the instructions therein.

## 10. PUTTING THE MACHINE OUT OF SERVICE

### 10.1 Putting the machine out of service temporarily

- Carry out all the cleaning and maintenance operations.
- Disconnect and wrap up the power supply cable.
- Disconnect the water supply tube.
- Cover the machine and store it in a dry place, not exposed to bad weather and with exclusive access.

For the conduction of the machine disconnection operations from the utility supply mains, please contact qualified personnel.

### 10.2 Putting the machine out of service definitely

- Disconnect and wrap up the power supply cable.
- Disconnect the water supply tube.
- Cut off the supply cable, pack up the machine and deliver it to personnel in charge of specifically certified waste recycling or used machinery collection centres.

## 11. TROUBLE SHOOTING

**The following are inspection operations that can be carried out by the operator with the machine powered down and unplugged from the power mains. For any other type of anomaly or non-specified machine inconveniency, unplug the machine from the power mains, do not proceed with direct attempts at repairing the machine and immediately contact qualified and authorised sales service network personnel.**

1) The machine will not start up:	<ul style="list-style-type: none"> <li>- Check to ensure that the power mains plug has been plugged in correctly</li> <li>- Check to ensure that the differential, magneto-thermal and main switches are all correctly engaged</li> <li>- Check the condition of the power supply cable and mains plug. If they are damaged, please contact qualified and authorised personnel for replacement.</li> </ul>
2) Water found under the machine	- Check to ensure that the tray discharge is not obstructed.
3) Slow dispensing speed	<ul style="list-style-type: none"> <li>- Check filter and spout/sprayer conditions to make sure they are clean.</li> <li>- Check to make sure that the coffee has not been ground too finely</li> </ul>
4) Irregular steam supply	- Check to ensure that the spout nozzles are not obstructed.

**WARRANTY CLAIM**

Dear Customer, the hereby form is a formal warranty claim to be sent via fax or e-mail as specified below. Please, to describe the matter occurred in the dedicated box. Beware, the BVG, could ask to return the faulty component back for quality inspection purposes. On top of that, to verify the right claiming.

It is recommended to do not remove the label with serial numbers to avoid to lose the warranty on the spare part.

Warranty policy available in the Use & Maintenance manual sent with machines and on the: [www.bianchivending.com](http://www.bianchivending.com)

To be sent to fax: **+39 035 883 304** or e-mail: **customer@bianchivending.com**

Model		Serial number	
Sender: (company title)		Sender telephone nr. (eventual call back by the BVG)	
Installation Date		Sender E-mail/ Fax nr. (to confirm the warranty being activated)	

**MATTER OCURED**

**REQUIRED PARTS**

	Code	Quantity
Missing parts		
Wiring/cable		
Electronics boards		
Power supply		
Keypad		
Hydraulic circuit		
Pump		
Electrovalve		
Motor/electromagnet		
Microswitch		
Coffee Group		
Grinder / doser		
Cup dispenser		
Stirrer Dispenser		
Refrigerator group		
Water filter		
Other		

**SATISFACTION NOTE**

(write eventual notes about product and/or service provided by the BVG. This to improve and better satisfy Your needs in the future)	
--	--



Modulo MO8.2_02 EN	<b>MODULO OPERATIVO</b>	
Rev.5 del 22/06/12		
Pag 1/1		

**FIRST INSTALLATION FORM - WARRANTY ACTIVATION**

Bianchi kindly asks to you to fill this form in once the process of first installation of the unit has been performed and to send it to us (via FAX or e-mail as specified below). If something goes wrong during the first installation process, please specify the matter occurred with relative brief description of the fact in the dedicated box, then send this form to the same fax n° or e-mail address as below. The one year warranty will start from the moment thst the hereby form is received correctly filled in all voices, else automatically the company will start the warranty from the date of sale of the unit.

It is reccomanded to do not remove the label with serial numbers to avoid to lose the warranty on the spare part.

Warraty policy available in the Use & Maintenance manual attached to machines and at: [www.bianchivending.com](http://www.bianchivending.com)

To be sent to fax: **+39 035 883 304** or e-mail: [customercare@bianchivending.com](mailto:customercare@bianchivending.com)

Model		Serial number	
Sender: (company title)		Sender telephone nr. (eventual call back by the BVG)	
Installation Date		Sender E-mail/ Fax nr. (to confirm the warranty being activated)	

**MATTER DURING THE FIRST INSTALLATION?**

YES

NO

**IF YES, WRITE HERE A DESCRIPTION**

**MATTER DURING FIRST INSTALLATION, SPECIFY SPARE PARTS REQUIRED**

	Code	Quantity
Missing parts		
Wiring/cable		
Electronics boards		
Power supply		
Keypad		
Hydraulic circuit		
Pump		
Electrovalve		
Motor/electromagnet		
Microswitch		
Coffee Group		
Grinder/doser		
Cup dispenser		
Stirrer Dispenser		
Refrigerator group		
Water filter		
Other		

**SATISFACTION NOTE**

(write eventual notes about product and/or service provided by the BVG. This to improve and better satisfy Your needs in the future)	
--	--







**BIANCHI VENDING GROUP s.p.A.**

*Corso Africa 9 - 24040 Località Zingonia, Verdellino (BG) - ITALIA  
tel. +39.035.4502111 - fax +39.035.883.304*