

SCOTT ISCBA INDUSTRIAL SELF-CONTAINED BREATHING APPARATUS MODEL 2216 ISCBA RESPIRATOR (2216 PSI) MODEL 4500 ISCBA RESPIRATOR (4500 PSI)

MODEL 2216 ISCBA RESPIRATOR (2216 PSI)

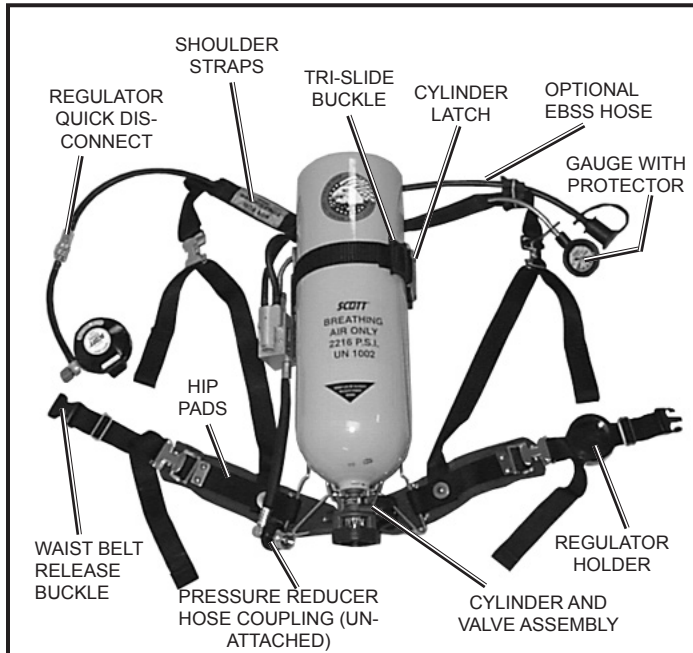

**TYPICAL INDUSTRIAL SCBA 2216 PSI
W/ OPTIONAL ACCESSORIES**

***For Use With 2216 PSI Cylinders of
30 Minute Rated Duration***

MODEL 4500 ISCBA RESPIRATOR (4500 PSI)

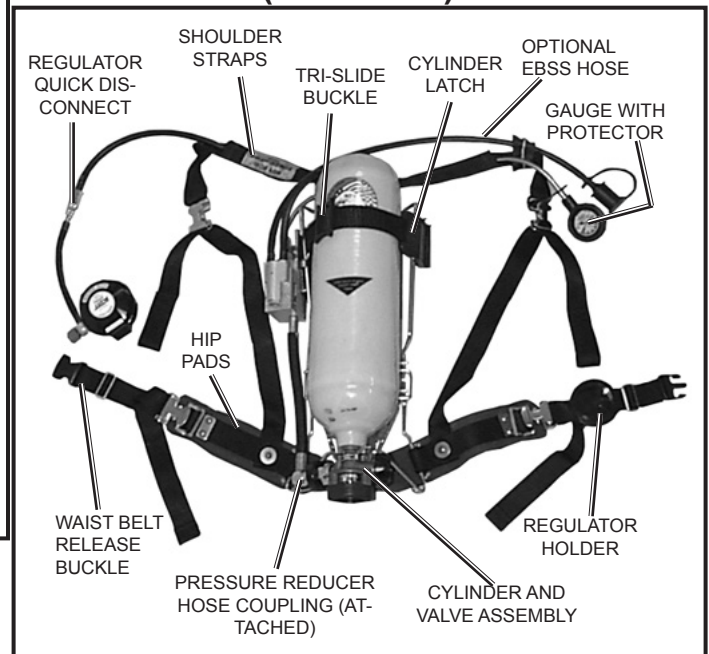

**TYPICAL INDUSTRIAL SCBA 4500 PSI
W/ OPTIONAL ACCESSORIES**

***For Use With 4500 PSI Cylinders of
30, 45, or 60 Minute Rated Duration***

WARNING

IMPROPER USE OF THIS RESPIRATOR MAY RESULT IN SERIOUS INJURY OR DEATH. IMPROPER USE INCLUDES, BUT IS NOT LIMITED TO, USE WITHOUT ADEQUATE TRAINING, DISREGARD OF THE WARNINGS AND INSTRUCTIONS CONTAINED HEREIN, AND FAILURE TO INSPECT AND MAINTAIN THIS RESPIRATOR.

THIS RESPIRATOR IS INTENDED TO BE USED ONLY IN CONJUNCTION WITH AN ORGANIZED RESPIRATORY PROTECTION PROGRAM WHICH COMPLIES WITH THE REQUIREMENTS OF "PRACTICES FOR RESPIRATORY PROTECTION", Z88.2 AVAILABLE FROM AMERICAN NATIONAL STANDARDS INSTITUTE INC., 1430 BROADWAY, NEW YORK, N.Y., 10018, OR THE REQUIREMENTS OF OSHA SAFETY AND HEALTH STANDARD 29 CFR 1910 PARAGRAPH 134 AVAILABLE FROM THE U.S. DEPARTMENT OF LABOR, OCCUPATIONAL SAFETY AND HEALTH ADMINISTRATION, OR OTHER PERTINENT NATIONALLY RECOGNIZED STANDARDS.

© 2011 Scott Safety

SCOTT, the SCOTT SAFETY Logo, Scott Health and Safety, ISCBA, AV-2000, AV-3000, SureSeal, Scott-O-Vista, and Weld-O-Vista are registered and/or unregistered marks of Scott Technologies, Inc. or its affiliates.

GENERAL DESCRIPTION

The SCOTT Industrial Self-Contained Breathing Apparatus (ISCBA) is a respirator designed to supply breathable air and respiratory protection to personnel while performing work in objectionable, oxygen deficient and/or unbreathable (toxic) atmospheres. Model 2216 ISCBA respirator uses a 2216 psi cylinder while Model 4500 ISCBA respirator uses a 4500 psi cylinder.

This respirator is to be used **only** by persons trained in the use of the respirator and **only** in conjunction with an organized respiratory protection program. This respirator is not to be used under water, for interior structural fire fighting or for any other purpose not authorized by the organized respiratory protection program that applies specifically to the user.

The respirator consists of a cylinder and valve assembly for storing compressed breathing air, a harness and backframe assembly to support the equipment on the body of the wearer, a single stage pressure reducer mounted on the backframe, a positive pressure facepiece-mounted breathing regulator, and a facepiece assembly.

The pressure reducer has an integral bell alarm to warn the user of diminishing air supply.

The ISCBA respirator is supplied with a steel wire frame fitted with a waist strap assembly, shoulder straps, and side straps. The straps are available either in nylon or flame resistant Kevlar¹ material.

The breathing regulator is equipped with an air saver/donning switch which can be activated to prevent rapid loss of air supply if the system is turned on prior to donning the facepiece or if the facepiece is removed while the cylinder valve is open. Respirators are available with or without a quick disconnect in the hose to the mask-mounted breathing regulator.

WARNING

DO NOT OPERATE THIS EQUIPMENT WHILE UNDER THE INFLUENCE OF DRUGS, ALCOHOL, OR ANY MEDICATIONS OR SUBSTANCES WHICH MAY AFFECT VISION, DEXTERITY, OR JUDGMENT. USERS OF THIS EQUIPMENT MUST BE IN GOOD PHYSICAL AND MENTAL HEALTH IN ORDER TO OPERATE SAFELY. DO NOT USE THIS EQUIPMENT WHEN FATIGUE PREVENTS SAFE OPERATION. STAY ALERT WHEN OPERATING THIS EQUIPMENT. INATTENTION OR CARELESSNESS WHILE OPERATING THIS EQUIPMENT MAY RESULT IN SERIOUS INJURY OR DEATH.

WARNING

THIS RESPIRATOR PROVIDES PROTECTION ONLY TO THE USER'S RESPIRATORY SYSTEM AND TO PART OF THE FACE. IF THE HAZARDOUS ATMOSPHERE CONTAINS TOXINS OR CONTAMINANTS WHICH MAY POISON THROUGH THE SKIN, ADDITIONAL PROTECTIVE EQUIPMENT MAY BE REQUIRED. FAILURE TO PROVIDE ADEQUATE PROTECTIVE EQUIPMENT FOR THE HAZARDS IN THE WORKPLACE MAY RESULT IN SERIOUS INJURY OR DEATH.

WARNING

DO NOT USE THIS RESPIRATOR FOR FIRE FIGHTING. USE OF THIS EQUIPMENT FOR FIRE FIGHTING MAY RESULT IN FAILURE OF THE EQUIPMENT WHICH COULD CAUSE SERIOUS INJURY OR DEATH.

WARNING

CERTAIN ENVIRONMENTS MAY REQUIRE THAT PROTECTIVE MATERIAL COVER SOME OR ALL OF THE RESPIRATOR IN ADDITION TO COVERING THE USER. THE USER MUST BE ABLE TO ACCESS THE CONTROLS OF THE RESPIRATOR AT ALL TIMES. INABILITY TO ACCESS CONTROLS OF THE RESPIRATOR WHEN THE RESPIRATOR IS NEEDED FOR ESCAPE MAY RESULT IN SERIOUS INJURY OR DEATH.

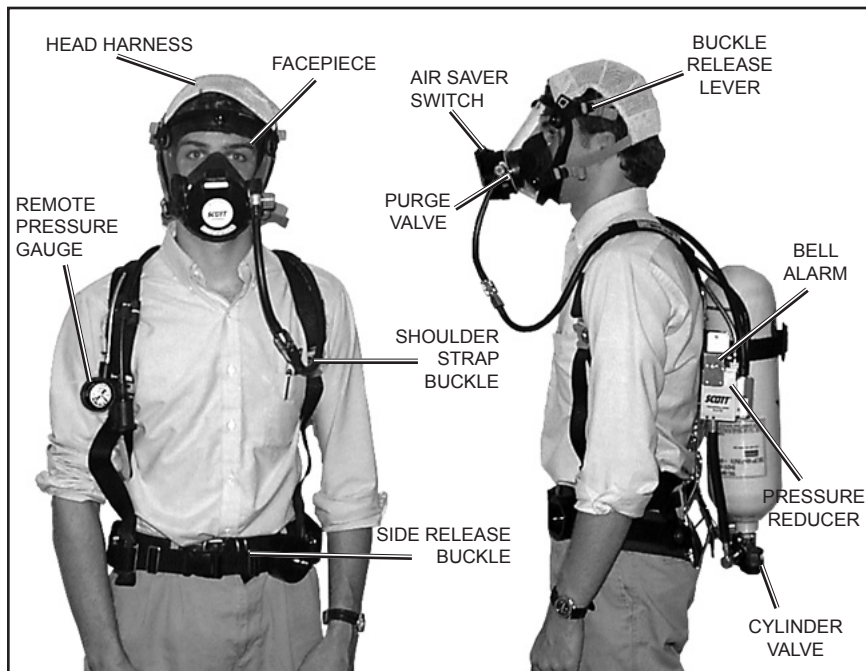

FRONT VIEW

LEFT SIDE VIEW

**TYPICAL INDUSTRIAL SCBA
(4500 PSI MODEL SHOWN)**

FIGURE 1

¹Kevlar is a registered trademark of E.I. du Pont de Nemours, Inc.

The facepiece utilized on this respirator is available in a variety of sizes and configurations for standard use or special applications. The facepiece may be readily detached from the breathing regulator to allow for utilization of the best fitting and most comfortable size facepiece for an individual user. Fit testing per OSHA Standard 29 CFR Part 1910 or ANSI Standard Z88.2 requires testing in the negative pressure mode using equipment such as a Portacount Plus² Respirator Fit Tester. For this, SCOTT facepieces require use of SCOTT Fit Test Adapter P/N 804057-01 or equivalent and appropriate negative pressure testing equipment. Mask Seal Kit P/N 805655-01 may also be required to attain a proper fit. Head harnesses are available in several materials including polyester and Kevlar¹. Each size facepiece may be equipped with a lens kit if the use of corrective spectacles is required. See ACCESSORIES Section for facepiece options.

The duration of the respirator may be extended by use of a low pressure airline air supply. (For details see ACCESSORIES Section.) The respirators are National Institute for Occupational Safety and Health (NIOSH) approved for use in temperatures to -25 °F / -32 °C.

Depending on the cylinder and valve used, the respirators are approved and maintained under NIOSH approval numbers listed on the NIOSH APPROVAL LABEL. These respirators meet the requirements of Title 42, Part 84 of the Code of Federal Regulations when used and maintained in accordance with these instructions and the NIOSH label located on the harness and backframe assemblies. A complete NIOSH APPROVAL LABEL is included with these instructions.

For assistance, contact your SCOTT authorized distributor or call SCOTT Safety at 1-800-247-7257.

QUESTIONS OR CONCERNS

If you have any questions or concerns regarding use of this equipment, contact your authorized SCOTT distributor, or contact SCOTT at 1-800-247-7257 (or 704-291-8300 outside the continental United States).

EXPORT AND IMPORT

The international transport of this equipment is regulated under United States export regulations and may be regulated by the import regulations of other countries.

If you have any questions or concerns regarding these regulations, contact SCOTT at 1-800-247-7257 (or 704-291-8300 outside the continental United States).

WARNING

RESPIRATORS SHALL NOT BE WORN WHEN CONDITIONS PREVENT A GOOD FACE SEAL. SUCH CONDITIONS MAY INCLUDE, BUT ARE NOT LIMITED TO, GROWTH OF BEARDS, SIDEBURNS, A SKULL CAP THAT PROJECTS UNDER THE FACEPIECE OR TEMPLE PIECES ON EYEGLASSES. ALSO, ABSENCE OF ONE OR BOTH DENTURES CAN SERIOUSLY AFFECT THE FIT OF A FACEPIECE. ANY CONDITION WHICH PREVENTS A GOOD FACE SEAL MAY PERMIT EXPOSURE TO THE HAZARDOUS ATMOSPHERE WHICH MAY RESULT IN SERIOUS INJURY OR DEATH.

WARNING

DO NOT USE THE BLACK POLYESTER HEAD HARNESS OR NYLON BACKFRAME HARNESS WHEN ACCIDENTAL EXPOSURE TO HIGH HEAT OR FLAME IS A POSSIBILITY. IN THOSE CIRCUMSTANCES, THE POLYESTER OR NYLON MAY MELT OR BURN CAUSING INJURY OR MAY INTERFERE WITH RESPIRATORY PROTECTION RESULTING IN SERIOUS INJURY OR DEATH.

²Portacount Plus is a registered trademark of TSI Incorporated

FACEPIECE FITTING AND FIT TESTING

A respirator Quantitative Fit Test must be performed to ensure the correct respirator facepiece size has been selected and assigned to the user. It is the responsibility of the Respiratory Protection Program Manager or Safety Coordinator to assist the user in selecting the correct respirator size relative to the user's facial features and dimensions. Fit Testing must be performed with any approved SCOTT accessories that will be used with the respirator installed, such as a communications device installed on the facepiece.

Respirator fit tests are explained fully in the American National Standard Practices for Respiratory Protection, ANSI Z88.10-2001 which is published by the American National Standards Institute (ANSI), 11 West 42nd Street, New York, New York, 10036, and in the Occupational Safety and Health Standards, OSHA 29 CFR 1910.134 Appendix A, which is published by the Occupational Safety and Health Administration (OSHA), 200 Constitution Avenue, NW, Washington DC, 20210.

Quantitative Fit Testing per OSHA Standard 29 CFR Part 1910.134 Appendix A, or ANSI Standard Z88.10-2001 requires testing in the negative pressure mode using equipment such as a Portacount¹ Respirator Fit Tester. For Quantitative Fit Testing, SCOTT facepieces require use of the appropriate negative pressure testing equipment such as the Portacount Respirator Fit Tester along with the following:

- SCOTT 40mm facepiece Adapter, P/N 200423-01,
- a new SCOTT P100 Cartridge, P/N 052683,
- SCOTT Probed Fit Test Adapter P/N 805628-01 or equivalent probed facepieces and the full range of sizes and styles
- Mask Seal Kit, P/N 805655-01
- the appropriate SCOTT communication device and mounting bracket properly installed on the facepiece, if such an accessory will be used with the respirator.
- any other optional hood, eyeglass, or other accessory that will be used with the respirator.

The size and style facepiece must be selected based on the user's measured face size. For initial fitting, carefully don the facepiece and conduct a NEGATIVE PRESSURE LEAK TEST according to the instructions provided with the 40mm Adapter. Refer to the DONNING PROCEDURE section of this instruction for the procedure. Follow the DONNING PROCEDURE **CAREFULLY**. If the selected facepiece does not pass the NEGATIVE PRESSURE LEAK TEST or does not fit securely without movement in the chin or chin cup area or the user experiences discomfort in the chin or throat, try the next nearest size, larger or smaller. After passing the NEGATIVE PRESSURE LEAK TEST, the facepiece size selected must be verified by successfully passing a respirator Quantitative Fit Test.

When fit testing for Open-Circuit, Pressure Demand Self-Contained Breathing Apparatus and/or Type C Pressure-Demand Supplied Air Respirator mode of operation (minimum Fit Factor equal to or greater than 500 minimum) appropriate negative pressure testing equipment must be used. You should use a P100 Filter, SCOTT P/N 052683 and the SCOTT P/N 805628-01 Fit Test Adapter.

When using a Portacount Respirator Fit Tester for Quantitative Fit Testing, TSI recommends that the level of particles in the ambient air must be between 5000 and 30000 particles/cm³. Refer to the Portacount Respirator Fit Tester user instructions for details including available Particle Generators to use with the Portacount Respirator Fit Tester if you have difficulty achieving the minimum level of ambient particle count required.

Test subjects must be in good health at the time of the fit testing. Smoking or eating less than 30 minutes prior to the test is prohibited. Any and all conditions that might interfere with a good face to facepiece seal must be addressed and corrected before performing the fit testing. Refer to the list of conditions in the DONNING PROCEDURES section of this instruction.

WARNING

THE USER MUST BE PROPERLY FITTED USING A RESPIRATOR QUANTITATIVE FIT TEST BEFORE USE AND FOLLOW ALL WARNINGS AND SPECIAL OR CRITICAL USER'S INSTRUCTIONS SPECIFIED DURING USE. FAILURE TO DO SO MAY RESULT IN SERIOUS INJURY OR DEATH.

WARNING

FIT TESTING IN ACCORDANCE WITH OSHA STANDARD 29 CFR PART 1910 IS REQUIRED AS PART OF THE REQUIRED TRAINING BEFORE USE OF THIS RESPIRATOR. FAILURE TO PROPERLY FIT AND TRAIN THE USER IN USE OF THE FACEPIECE AND RESPIRATOR MAY RESULT IN EXPOSURE TO THE HAZARDOUS ATMOSPHERE WHICH COULD LEAD TO SERIOUS INJURY OR DEATH.

WARNING

RESPIRATORS SHALL NOT BE WORN WHEN CONDITIONS PREVENT A GOOD FACE SEAL. SUCH CONDITIONS MAY INCLUDE, BUT ARE NOT LIMITED TO, GROWTH OF BEARDS, SIDEBURNS, FACIAL HAIR OR LOW HAIRLINE THAT CROSSES OR INTERFERES WITH THE SEALING SURFACE, THICK OR PROTRUDING HAIRSTYLES SUCH AS PONY TAILS OR BUNS THAT INTERFERE WITH THE SMOOTH AND CLOSE FIT OF THE HEAD HARNESS TO THE HEAD, A SKULL CAP THAT PROJECTS UNDER THE FACEPIECE, TEMPLE PIECES ON CORRECTIVE EYE GLASSES, EXCESSIVE USE OF COSMETICS INCLUDING MOISTURIZERS, MAKE-UP, OR AFTER SHAVE, OR ANYTHING ELSE WHICH INTERFERES WITH THE FACE TO FACEPIECE SEAL. ALSO, THE ABSENCE OF ONE OR BOTH DENTURES CAN SERIOUSLY AFFECT THE FIT OF A FACEPIECE. USE OF AN IMPROPERLY FITTED FACEPIECE MAY LEAD TO EXPOSURE TO THE HAZARDOUS ATMOSPHERE WHICH COULD RESULT IN SERIOUS INJURY OR DEATH.

To verify the fit factor of the respirator, testing must incorporate an exercise regimen of normal daily activities. SCOTT requires the following set of fit test exercises, which are based on OSHA Standard 29 CFR Part 1910.134 Appendix A, and ANSI Z88.10-2001 with modifications.

Exercises are to be performed each for 60 seconds (except as noted) in a standing position during the test:

- Normal Breathing
- Deep breathing
- Turning head side to side
- Moving head up and down (look up/look down)
- Talking (read the Rainbow Passage)
- Grimace (15 seconds)
- Bending Over (touch toes) / Reach up (toward the ceiling)
- Normal Breathing (repeat)

Fit test exercises must be performed carefully as if the respirator was being used in a hazardous atmosphere. DO NOT bump the facepiece, filter, or adapter into the body through exaggerated motions. DO NOT talk except when directed to by the test administrator.

SCOTT requires that users of this respirator with an approved SCOTT facepiece, must achieve a Fit Factor of at least 500 for Type C Pressure-Demand Supplied Air Respirator mode of operation for use with their assigned facepiece style and size using the fit test procedures and exercise regimen stated above. If a Fit Factor of at least 500 cannot be achieved with any facepiece size or style, the user MUST NOT use this respirator.

If the respirator user passes a NEGATIVE PRESSURE LEAK TEST but DOES NOT pass a respirator Quantitative Fit Test, try the next nearest size, larger or smaller and repeat the NEGATIVE PRESSURE LEAK TEST and the Quantitative Fit Test. If leakage is still detected, either per these user instructions or the OSHA fit testing process, the use of Mask Seal Kit P/N 805655-01 may be required to attain a proper fit. Refer to the INSTALLATION AND USE INSTRUCTIONS, SCOTT P/N 89462-01, included with the Mask Seal Kit. After installing the Mask Seal Kit, repeat the fit testing process to confirm a proper fit.

Once the proper size is selected and assigned to the user following successful Portacount Respirator Fit Tester testing to achieve minimum Fit Factors required, the respirator user must perform and pass a NEGATIVE PRESSURE LEAK TEST as described in these instructions every time the facepiece is donned to ensure proper fit before using the respirator in a hazardous atmosphere.

During NEGATIVE PRESSURE LEAK TESTING, any facepiece leakage that is detected from other than the face to facepiece seal may indicate damaged or defective equipment. Remove the defective equipment from service and tag for repair by authorized personnel. Repeat the testing with equipment known to be operating properly.

IF A SATISFACTORY NEGATIVE PRESSURE LEAK TEST CANNOT BE PERFORMED, DO NOT USE THE RESPIRATOR OR ENTER THE HAZARDOUS ATMOSPHERE.

The facepiece alone does not provide any protection against a hazardous atmosphere without the use of the complete respirator.

A respirator Quantitative Fit Test must be routinely carried out as outlined above for each user of this respirator to determine or confirm the amount of protection that the respirator provides.

Periodically repeating the fit testing is required to identify any physical changes of the user (such as those listed in the DONNING PROCEDURES) which could effect the fit of the facepiece.

CHOOSING THE APPROPRIATE EQUIPMENT

Respirators reduce but do not eliminate all exposure to the hazardous atmosphere. Some facepiece/respirator combinations are more effective than others at reducing exposure depending on the nature and the concentration of the contaminant in the hazardous atmosphere. When choosing a respirator and facepiece, the respiratory protection program under which this respirator is to be used must determine the appropriate level of protection that the facepiece/respirator is expected to provide. **Use of inappropriate RESPIRATOR equipment for the work environment may result in exposure to the hazardous atmosphere which may cause serious injury or death.**

The respiratory protection program must also take into consideration the levels of exposure which may be hazardous irrespective of respiratory protection (e.g.: contaminants which are toxic through exposure to unprotected skin). Additional protective equipment such as apparel may be required. However, any additional protective equipment must not interfere with access to or operation of the respirator.

When properly donned and operated, the SCOTT ISCBA respirator provides limited protection from airborne contaminants to only the respiratory system and part of the face of the user. The using agency must provide the appropriate protective clothing for use with the ISCBA respirator and must insure that protective clothing does not interfere with the operation of the ISCBA respirator.

NIOSH approval is granted to respiratory protection equipment made up of specific combinations of parts or assemblies that have been successfully tested to the performance standards established by the approval agencies.

To maintain NIOSH approval, an AV-3000 facepiece equipped with a SureSeal face seal P/N 31001738 (Small), P/N 31001739 (Medium), or P/N 31001740 (Large) must be used **only** with Grey Nose Cup P/N 31001043 (Small), P/N 31001044 (Medium), or P/N 31001045 (Large).

If you are using an AV-3000 facepiece equipped with a SureSeal face seal and do not have a Grey Nose Cup, contact SCOTT or your authorized SCOTT distributor. Failure to comply with this requirement will void the approvals for your respirator. Use of a non-approved configuration in a hazardous atmosphere may result in serious injury or death.

SERVICE LIFE

The 2216 ISCBA respirator is rated and approved by NIOSH as a 30 minute duration unit and the 4500 ISCBA respirator is rated and approved by NIOSH as a 30 minute / 45 minute / 60 minute duration unit (depending on capacity of cylinder used) when properly donned, used and maintained by trained personnel. A bell alarm actuates when approximately 25% of the rated service time remains. The alarm will continue to operate until the cylinder is nearly depleted.

The user should not expect to obtain exactly the rated service life from this respirator on each use. The work being performed may be more or less strenuous than that used in the NIOSH test. Where work is more strenuous, the duration may be shorter, possibly as short as one-half the rated service time. Likewise, the time remaining after the bell alarm actuates will be similarly reduced.

The duration of the respirator will depend on such factors as:

1. the degree of physical activity of the user;
2. the physical condition of the user;
3. the degree to which the user's breathing is affected by excitement, fear or other emotional factors;
4. the degree of training or experience which the user has with this or similar equipment;
5. whether or not the cylinder is fully charged at the start of the work period;
6. the possible presence in the compressed air of carbon dioxide concentrations greater than .04% normally found in atmospheric air;
7. the atmospheric pressure; for example, if used in a pressurized tunnel or caisson at 2 atmospheres (15 psi gauge) the duration will be one-half as long as when used at 1 atmosphere; and at 3 atmospheres will be one-third as long;
8. loose or improperly fitting facepiece;
9. the condition of the respirator being used.

WARNING

THE RESPIRATORY PROTECTION PROGRAM UNDER WHICH THIS EQUIPMENT IS TO BE USED MUST DETERMINE THE APPROPRIATE LEVEL OF PROTECTION THAT THE RESPIRATOR IS EXPECTED TO PROVIDE. USE OF INAPPROPRIATE RESPIRATOR EQUIPMENT FOR THE WORK ENVIRONMENT MAY RESULT IN EXPOSURE TO THE HAZARDOUS ATMOSPHERE WHICH MAY CAUSE SERIOUS INJURY OR DEATH.

WARNING

THIS RESPIRATOR PROVIDES PROTECTION ONLY TO THE USER'S RESPIRATORY SYSTEM AND TO PART OF THE FACE. IF THE HAZARDOUS ATMOSPHERE CONTAINS TOXINS OR CONTAMINANTS WHICH MAY POISON THROUGH THE SKIN, ADDITIONAL PROTECTIVE EQUIPMENT MAY BE REQUIRED. FAILURE TO PROVIDE ADEQUATE PROTECTIVE EQUIPMENT FOR THE HAZARDS IN THE WORKPLACE MAY RESULT IN SERIOUS INJURY OR DEATH.

WARNING

TO MAINTAIN NIOSH APPROVAL, AN AV-3000 FACEPIECE EQUIPPED WITH A SURESEAL FACE SEAL P/N 31001738 (SMALL), P/N 31001739 (MEDIUM), OR P/N 31001740 (LARGE) MUST BE USED ONLY WITH GREY NOSE CUP P/N 31001043 (SMALL), P/N 31001044 (MEDIUM), OR P/N 31001045 (LARGE). USE OF A NON-APPROVED CONFIGURATION IN A HAZARDOUS ATMOSPHERE MAY RESULT IN SERIOUS INJURY OR DEATH.

WARNING

THE RESPIRATOR USER MUST IMMEDIATELY LEAVE THE AREA REQUIRING RESPIRATORY PROTECTION WHEN THE BELL END OF SERVICE INDICATOR ALARM ACTUATES. ACTUATION OF THE BELL END OF SERVICE INDICATOR ALARM WARNS THAT APPROXIMATELY 25% OF FULL PRESSURE REMAINS IN THE AIR SUPPLY CYLINDER (THAT IS, APPROXIMATELY 3/4 OF THE TOTAL AIR SUPPLY HAS BEEN USED). A DELAY IN LEAVING THE AREA AFTER ALARM ACTUATION MAY RESULT IN INJURY OR DEATH.

WARNING

FAILURE TO PROPERLY FIT THE RESPIRATOR FACEPIECE TO THE USER MAY RESULT IN LITTLE OR NO RESPIRATORY PROTECTION AND MAY EXPOSE THE WEARER TO SUBSTANCES WHICH CAN CAUSE SERIOUS INJURY OR DEATH.

ACCESSORIES

1. Neck Strap, P/N 804088-01, is used to hold facepiece in a ready position.
2. Hard carrying case, P/N 804497-01, and soft carrying case, P/N 10009324, are used to store and transport respirator.
3. Duration Extending Accessory Hose Assembly is used for the purpose of extending duration by means of a low pressure airline air supply.

NOTE

ONLY RESPIRATORS EQUIPPED WITH A DUAL OUTLET REDUCER CAN HAVE THE DURATION EXTENDING ACCESSORY HOSE INSTALLED.

4. A variety of Lens Kits are available to allow installation of corrective lenses in facepiece.
5. Gauge Protector Kit, P/N 804091-01, provides the remote reading pressure gauge with protection from impact and abrasion.
6. Clear protective Lens Cover, P/N 803941-25 (package of 25), is used to protect full facepiece lens against external scratching, spatter, paint spray and abrasion.
7. Nose Cup Assembly, P/N 802819-01, is used to minimize fogging in the SCOTT-O-VISTA facepiece and is required for use in temperatures below 32 °F / 0 °C. Nose Cup installation kit, P/N 802862-01, must be ordered when installing nose cup in the facepiece for the first time. The installation kit contains the nose cup, adhesive and the required mounting components.
8. Several communications devices are available for use with SCOTT Full Facepieces with dual voicemitters. Consult with your SCOTT distributor for details
9. Suit Pass-Thru Assembly, 803620 series, provides a means of delivering respirable air to specific SCOTT SCBA worn in combination with a protective garment or suit.
10. Refer to the FACEPIECE FITTING AND FIT TESTING section of this instruction for information about Fit Testing Accessories. Consult your SCOTT distributor for details of availability and application.
11. Emergency Breathing Support System (EBSS) allows 2 users of similarly equipped SCBA's to share a common air supply in the event one user has an emergency.
12. Regulator Holder, P/N 10008880, attaches to the waist belt to conveniently keep the breathing regulator secure and clean when not in use.
13. Facepieces for the respirator are available in a variety of sizes and configurations. Consult with your SCOTT distributor for details about SCOTT complete line of standard and special purpose full facepieces.

WARNING

THE INFORMATION BELOW IS MEANT TO SUPPLEMENT, NOT REPLACE, THE INSTRUCTIONS, TRAINING, SUPERVISION, MAINTENANCE, AND OTHER ELEMENTS OF YOUR ORGANIZED RESPIRATORY PROTECTION PROGRAM. SEE WARNING ON PAGE 1 OF THIS DOCUMENT. FAILURE TO HEED ANY WARNINGS IN THIS INSTRUCTION MAY RESULT IN SERIOUS INJURY OR DEATH.

REGULAR OPERATIONAL INSPECTION

The following procedure shall be used when you first receive the respirator and for regular inspection of the respirator. Respirators maintained for emergency use must be inspected as frequently as required to assure the respirator will function properly when required. The US Labor Department (OSHA), pursuant to 29 CFR 1910.134, requires at least monthly inspection of respirators maintained for emergency use. NIOSH recommends an inspection for cylinder pressure at least weekly. All respirators shall be inspected after each use. If any damage or malfunction is noted, remove the respirator from service and tag for repair by authorized personnel.

IF ANY DISCREPANCY OR MALFUNCTION IS NOTED DURING THE INSPECTION, DO NOT USE THE RESPIRATOR. REMOVE THE RESPIRATOR FROM SERVICE AND TAG IT FOR REPAIR BY AUTHORIZED PERSONNEL.

INSPECTION OF THE BREATHING AIR CYLINDER

1. Visually inspect breathing air cylinder and valve assembly for physical damage such as dents or gouges in metal or in composite wrapping. Cylinders which show physical damage or exposure to high heat or flame, such as paint turned brown or black, decals charred or missing, pressure gauge lens melted or elastomeric bumper distorted, and cylinders which show evidence of exposure to chemicals such as discoloration, cracks in the cylinder or the composite wrapping, peeling of the outer layers of the composite wrapping and/or bulging of the cylinder wall, shall be removed from service and emptied of compressed air. Publications on compressed gas cylinder inspection procedures are available from Compressed Gas Association Inc., 1725 Jefferson Davis Hwy., Suite 1004, Arlington, VA 22202 (703-412-0900).
2. Check the latest cylinder hydrostatic test date to ensure it is current. The date of manufacture marked on the cylinder is also the date of the first hydrostatic test. All breathing air cylinders used with SCOTT AIR-PAK SCBA's must be visually inspected regularly and hydrostatically tested at the required intervals by a licensed cylinder retester. Intervals for hydrostatic testing are established in the appropriate US Department of Transportation (DOT) specification or applicable DOT exemption, or in the appropriate Transport Canada (TC) Permit of Equivalent Level of Safety. Refer to the current revision of *Safety Precautions for AIR-PAK Cylinders*, SCOTT P/N 89080-01, available on request from SCOTT Safety. Composite fiber overwrapped cylinders must be tested up to their maximum life which, at the time of the publication of this instruction, is 15 years from the date of manufacture. It is the responsibility of your organized respiratory protection program to arrange for visual inspection and hydrostatic testing of cylinders by a licensed retester.
3. Check for damage of the cylinder valve hand wheel and the threads on the cylinder valve outlet.
4. Check the relief valve (burst disc) for damage or dirt.
5. Check the cylinder pressure gauge for "FULL" indication. If cylinder pressure is less than "FULL," replace with a fully charged cylinder.

Proceed to **INSPECTION OF THE RESPIRATOR**

WARNING

FOLLOW THE REGULAR OPERATIONAL INSPECTION PROCEDURE EXACTLY. IF THE END OF SERVICE INDICATOR ALARM DOES NOT ACTUATE AS DESCRIBED IN THIS INSTRUCTION, THE PURGE DOES NOT ACTUATE AS DESCRIBED IN THIS INSTRUCTION OR ANY OTHER OPERATIONAL MALFUNCTION IS NOTED, DO NOT USE THE RESPIRATOR. REMOVE THE RESPIRATOR FROM SERVICE AND TAG IT FOR REPAIR BY AUTHORIZED PERSONNEL. FAILURE TO PROPERLY IDENTIFY MALFUNCTIONS MAY RESULT IN SERIOUS INJURY OR DEATH.

WARNING

THE SMALL VENT HOLES IN THE PRESSURE REDUCER MUST BE CLEAR AND UNOBSTRUCTED FOR PROPER OPERATION OF THE RESPIRATOR. OBSTRUCTION OF THE VENT HOLES EITHER BY DIRT ACCUMULATION OR CARELESS APPLICATION OF USER LABELING MAY RESULT IN A MALFUNCTION OF THE RESPIRATOR WHICH COULD LEAD TO SERIOUS INJURY OR DEATH.

WARNING

DAMAGED CYLINDERS MAY SUDDENLY LEAK OR RUPTURE IF LEFT CHARGED WITH COMPRESSED AIR. FAILURE TO INSPECT FOR DAMAGE AND TO EMPTY THE AIR FROM DAMAGED CYLINDERS MAY RESULT IN SERIOUS INJURY OR DEATH.

INSPECTION OF THE RESPIRATOR

If any damage is found in this inspection, remove the respirator from service and tag for repair by authorized personnel.

1. Inspect the complete respirator for worn or damaged components.
 - a) Inspect hoses and rubber parts which exhibit cracking, splitting, or brittleness.
 - b) Inspect harness webbing for cuts, tears, abrasion, fraying, or indication of heat or chemical damage.
 - c) Check all buckles and fasteners for proper operation.
 - d) Check the cylinder retention system for damage and for proper operation.
 - e) Verify that the respirator has been properly cleaned.
2. Remove the breathing regulator from the facepiece by pulling back on the regulator retaining latch and rotating the regulator $\frac{1}{4}$ turn. Inspect the gasket on the breathing regulator that seals against the facepiece for rips or damage that may break the seal.
3. Inspect the breathing regulator for damaged or missing components.
 - a) Verify that the regulator gasket is not damaged and is in place around the outlet port of the regulator.
 - b) Verify that the purge valve (red knob) is not damaged and turns smoothly one-half turn from stop to stop.
4. If the breathing regulator is equipped with a MODULAIR quick disconnect, SEPARATE the regulator from the respirator by pushing THE MALE PLUG INTO THE coupling connection WHILE pulling back on the outer sleeve of the female coupling. The disconnect will separate. See FIGURE 2.

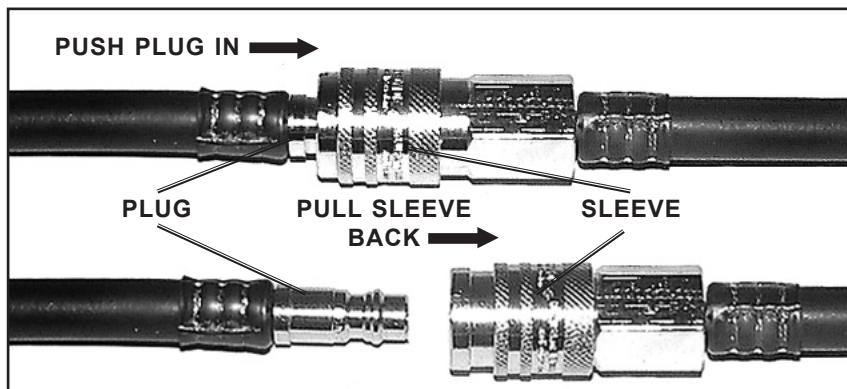

FIGURE 2

Reconnect the coupling by pushing the plug into the coupling until the sleeve snaps forward. Check that the disconnect is engaged properly by tugging on the coupling.

5. Verify that a FULL cylinder is properly installed in the backframe and that the reducer hose coupling is hand tightened to the cylinder valve outlet.

Proceed to ***INSPECTION OF THE FACEPIECE.***

**REGULAR OPERATIONAL INSPECTION
CONTINUED ON NEXT PAGE...**

WARNING

RESPIRATORS MUST BE CLEANED AND INSPECTED BEFORE STORAGE FOR REUSE. RESPIRATORS WITH WORN OR DAMAGED COMPONENTS SHALL NOT BE STORED FOR REUSE. REPLACE WORN OR DAMAGED COMPONENTS DURING INSPECTION OR REMOVE THE RESPIRATOR FROM SERVICE AND TAG IT FOR REPAIR BY AUTHORIZED PERSONNEL. USE OF A RESPIRATOR WITH WORN OR DAMAGED COMPONENTS MAY RESULT IN SERIOUS INJURY OR DEATH.

CAUTION

DO NOT USE TOOLS TO OPEN OR CLOSE THE PURGE VALVE. OPEN OR CLOSE BY USING FINGER-PRESSURE ONLY. ROTATION OR THE PURGE VALVE IS LIMITED TO $\frac{1}{2}$ TURN. USE OF TOOLS TO OPEN OR CLOSE PURGE VALVE MAY RESULT IN DAMAGE TO THE PURGE VALVE.

WARNING

FAILURE TO CHECK ENGAGEMENT OF THE COUPLING AS DESCRIBED MAY LEAD TO HOSE SEPARATION AND LOSS OF BREATHING AIR RESULTING IN SERIOUS INJURY OR DEATH.

REGULAR OPERATIONAL INSPECTION Continued...

INSPECTION OF THE FACEPIECE

Examine the facepiece assembly for damaged or worn components. The facepiece must be complete and in serviceable condition with no worn, loose, or damaged components.

- The AV-2000 style facepieces include the AV-2000, the Weld-O-Vista, and the Scott-O-Vista (the Scott-O-Vista does not have voicemitters).
- The AV-3000 style facepieces include the AV-3000 and the AV-3000 SureSeal.

Inspect the facepiece as follows:

1. Inspect the facepiece seal and other rubber components for deformation, wear, damage, or cracks.
2. Inspect the lens for cracks, gouges, scratches, or any condition that could impair the operation of the facepiece or the user's vision.
3. Inspect the lens frame or bezel for damage such as cracks or distortion.
4. Check that all lens frame retainers or bezel screws are present and installed correctly.
5. Check that all harness anchors are present and operating properly.
6. Inspect the head harness for correct installation with all straps oriented correctly.
7. Inspect the head harness for damage or worn components.
8. Inspect the voicemitters for dents or damage. Verify that the voicemitters are properly installed and secure in the voicemitter ducts.
9. Inspect the nose cup for cuts or damage. Also look for any signs of damage to the facepiece port side of the nose cup where the regulator attaches.
10. Check that the nose cup is properly seated between the flanges of the voicemitter ducts. See FIGURE 3.

CAUTION
IF THE NOSE CUP IS REMOVED FOR INSPECTION, MAKE CERTAIN IT IS REASSEMBLED CORRECTLY FOR THE MODEL FACEPIECE AND STYLE OF NOSE CUP.



FIGURE 3
Checking Voicemitter Ducts

11. All SCOTT facepieces used with this respirator may be fitted with a nose cup. Verify that the Nose Cup is properly installed for the model of facepiece being used. A Nose Cup is standard on the SCOTT AV-2000, Weld-O-Vista, and AV-3000 full facepieces and optional on the SCOTT-O-VISTA full facepiece.
 - a) SCOTT AV-3000 Facepieces are available with two different styles of nose cup: a BLACK Nose Cup which fits behind the face seal, and a GRAY Nose Cup which fits in front of the face seal. The BLACK Nose cup must be fitted BEHIND the Face Seal as shown in FIGURE 4. The GRAY Nose Cup must be fitted IN FRONT OF the Face Seal as shown in FIGURE 5.

AV-3000 FACEPIECES ONLY



FIGURE 4
BLACK Nose Cup
BEHIND Face Seal



FIGURE 5
GRAY Nose Cup
IN FRONT OF Face Seal

- b) The AV-2000, the Weld-O-Vista, and the SCOTT-O-VISTA, the Nose Cup always goes **BEHIND** the face seal **REGARDLESS** of the color of the nose cup. See FIGURE 6.

AV-2000 FACEPIECES ONLY

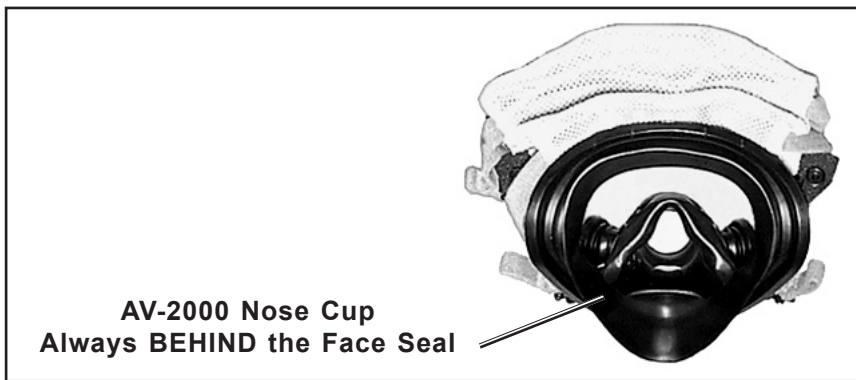

FIGURE 6

12. Verify that the facepiece is clean.
 13. Adjust the head straps to the full outward position.
- If no damage is found, proceed to the **OPERATIONAL TESTING**.

OPERATIONAL TESTING

1. Fully depress the center of the air saver/donning switch on the top of the regulator and release.
2. Slowly open the cylinder valve by fully rotating knob counterclockwise. The bell alarm shall actuate and then stop. There shall be no airflow from the facepiece
3. Don the facepiece or hold the facepiece to the face to effect a good seal. Inhale sharply to automatically start the flow of air. Breathe normally from the facepiece to ensure proper operation.
4. Remove facepiece from face. Air shall freely flow from the facepiece.
5. Fully depress the center of the air saver/donning switch on the top of regulator and release. The flow of air from the facepiece shall stop.
6. Rotate purge valve 1/2 turn counterclockwise (pointer on knob downward). Air shall freely flow from the regulator.
7. Rotate purge valve 1/2 turn clockwise to full closed position (pointer on knob upward). Airflow from regulator shall stop.
8. Push in and rotate cylinder valve knob clockwise to close. When cylinder valve is fully closed, open purge valve slightly to vent residual air pressure from system. The bell alarm shall actuate as the pressure drops below approximately 1/4 full. When airflow stops, return purge valve to the fully closed position (pointer on knob upward).

WARNING

FAILURE TO CHECK ENGAGEMENT OF THE COUPLING AS DESCRIBED MAY LEAD TO HOSE SEPARATION AND LOSS OF BREATHING AIR RESULTING IN SERIOUS INJURY OR DEATH.

CAUTION

WRENCHES SHALL NOT BE USED TO TIGHTEN THE HOSE COUPLING. OVER TIGHTENING THE HOSE COUPLING MAY DAMAGE THE NIPPLE SEAL.

CAUTION

DO NOT USE TOOLS TO OPEN OR CLOSE THE PURGE VALVE. OPEN OR CLOSE BY USING FINGER-PRESSURE ONLY. ROTATION OF THE PURGE VALVE IS LIMITED TO 1/2 TURN. USE OF TOOLS TO OPEN OR CLOSE PURGE VALVE MAY RESULT IN DAMAGE TO THE PURGE VALVE.

CAUTION

OVERTIGHTENING THE CYLINDER VALVE MAY CAUSE DAMAGE THAT COULD RESULT IN LEAKAGE OF AIR FROM THE CYLINDER. USE NO TOOLS TO CLOSE THE CYLINDER VALVE.

WARNING

IF THE END OF SERVICE INDICATOR BELL ALARM DOES NOT ACTUATE AS DESCRIBED IN THIS INSTRUCTION, DO NOT USE THE RESPIRATOR. REMOVE THE RESPIRATOR FROM SERVICE AND TAG IT FOR REPAIR BY AUTHORIZED PERSONNEL. USE OF AN IMPROPERLY OPERATING END OF SERVICE INDICATOR BELL ALARM MAY RESULT IN SERIOUS INJURY OR DEATH.

USE OF THE RESPIRATOR

The following information provides the basic steps for use of the ISCBA respirator. Training and practice with the equipment are required before use to assure that the user is completely familiar with the operation of the respirator.

The ISCBA respirator is typically worn over most protective garments, but may be worn under encapsulating protective garments such as haz-mat suits. Determine what other protective gear will be used and don the ISCBA respirator and the facepiece accordingly.

If respirator use is expected at temperatures near or below freezing, or if respirator is to be used after being kept at temperatures near or below freezing, refer to LOW TEMPERATURE OPERATION Section for additional information and supplemental procedures.

PREPARATION FOR USE

DONNING THE ISCBA RESPIRATOR

1. Always check the cylinder gauge for a "FULL" indication. If the cylinder is not full, replace the cylinder before use. A gauge indication of other than full may indicate an air leak in the cylinder and valve assembly or a malfunction of the gauge assembly.
2. Always verify that the cylinder is held securely by the cylinder retention assembly.
3. If the respirator is stored in a hard or soft storage case:
 - a) Place the case on the ground or level surface and open the case.
 - b) Stand the respirator on the cylinder valve with cylinder toward you and the shoulder straps away from you.
 - c) Grasp both shoulder pads, one in each hand.
 - d) Pick up the respirator and swing it around behind you.
 - e) Release your grasp while sliding your arms under the shoulder pads. Ensure that the shoulder pads fall into place on the shoulders.
 - f) While leaning slightly forward, pull down on the shoulder straps to adjust the harness to fit your body.
4. If a wall storage bracket is used, follow the instructions of the bracket manufacturer for placing arms through shoulder straps and freeing the respirator from the bracket.
 - a) Ensure that the shoulder pads fall into place on the shoulders.
 - b) While leaning slightly forward, pull down on the shoulder straps to adjust the harness to fit your body.
5. While still leaning slightly forward, connect the waist belt buckle and adjust the belt by pulling forward on the two (2) side-mounted belt ends. Tuck the belt ends into the waistband.
6. Stand up straight and readjust the shoulder straps as needed to ensure the weight of the backframe is carried on the hips. Tuck the shoulder strap ends under the shoulder straps.
7. Fully depress the center of the air saver/donning switch on top of regulator and release.
8. If the regulator is not attached to the facepiece, proceed as follows:
 - a) Verify that the regulator gasket is not damaged and is in place around the outlet port of the regulator.
 - b) Align the two flats of the regulator outlet port with the corresponding flats in the facepiece port (the red purge valve on the regulator will be in the 12 o'clock position). Insert the regulator into the facepiece port.
 - c) Rotate the regulator counterclockwise (as viewed from inside of facepiece) until the red purge valve knob is on the left side of the facepiece. The lock tab on the regulator will lock into the facepiece retainer with a "click." When the lock tab is properly engaged, the regulator will not rotate.

WARNING

THE INFORMATION IN THIS INSTRUCTION IS MEANT TO SUPPLEMENT, NOT REPLACE, THE INSTRUCTIONS, TRAINING, SUPERVISION, MAINTENANCE, AND OTHER ELEMENTS OF YOUR ORGANIZED RESPIRATORY PROTECTION PROGRAM. SEE WARNING ON PAGE ONE OF THIS DOCUMENT. FAILURE TO HEED ANY WARNINGS IN THIS INSTRUCTION MAY RESULT IN SERIOUS INJURY OR DEATH.

WARNING

BEFORE ENTERING A POTENTIALLY HAZARDOUS ATMOSPHERE OR UNKNOWN CONDITION, THE USER MUST DETERMINE THAT THE CYLINDER CONTAINS SUFFICIENT AIR TO ALLOW TIME FOR COMPLETION OF THE TASK INVOLVED AND RETURN TO A SAFE ATMOSPHERE WITH AN ADEQUATE MARGIN FOR SAFETY. THE USER SHOULD ALWAYS START WITH A FULL TANK. PARTIALLY FILLED TANKS SHOULD ONLY BE USED IN EMERGENCY CONDITIONS IF FULL TANKS ARE NOT AVAILABLE. ENTERING A HAZARDOUS ATMOSPHERE WITH INSUFFICIENT AIR OR AFTER THE END OF SERVICE TIME INDICATOR HAS ACTUATED MAY RESULT IN SERIOUS INJURY OR DEATH.

WARNING

FAILURE TO CHECK ENGAGEMENT OF THE COUPLING AS DESCRIBED MAY LEAD TO HOSE SEPARATION AND LOSS OF BREATHING AIR RESULTING IN SERIOUS INJURY OR DEATH.

WARNING

THE CYLINDER VALVE MUST BE FULLY OPENED FOR PROPER OPERATION OF THE RESPIRATOR. USE OF A RESPIRATOR WITH THE CYLINDER VALVE PARTIALLY OPENED MAY CAUSE A REDUCTION OF THE AIR SUPPLIED TO THE USER AND/OR A SUDDEN AND COMPLETE LOSS OF AIR SUPPLIED TO THE USER. A REDUCTION OR LOSS OF AIR TO THE USER MAY RESULT IN EXPOSING THE USER TO THE ATMOSPHERE THE RESPIRATOR IS INTENDED TO PROTECT AGAINST AND LEAD TO SERIOUS INJURY OR DEATH.

CHECK THE OPERATION OF THE ISCBA RESPIRATOR

1. Slowly open cylinder valve fully by turning the valve knob counterclockwise until it stops (approximately 2 1/2 full turns of the knob). The bell alarm shall actuate and then stop. There shall be no airflow from the facepiece
2. Don the facepiece or hold the facepiece to the face to effect a good seal. Inhale sharply to automatically start the flow of air. Breathe normally from the facepiece to ensure proper operation.
3. Remove facepiece from face. Air shall freely flow from the facepiece.
4. Fully depress the center of the air saver/donning switch on the top of regulator and release. The flow of air from the facepiece shall stop.
5. Rotate purge valve 1/2 turn counterclockwise (pointer on knob downward). Air shall freely flow from the regulator.
6. Rotate purge valve 1/2 turn clockwise to full closed position (pointer on knob upward). Airflow from regulator shall stop.
7. Push in and rotate cylinder valve knob clockwise to close. When cylinder valve is fully closed, open purge valve slightly to vent residual air pressure from system. The bell alarm shall actuate as the pressure drops below approximately 1/4 full. When airflow stops, return purge valve to the fully closed position (pointer on knob upward).
8. The user of the respirator is now in "standby" condition. The respirator is in place on the user's body but the facepiece is not donned (sealed to the face) and the respirator is not being used. Keep the facepiece ready for use either of two ways:
 - a) Hang the facepiece from the snap clip on the left shoulder pad,
 - b) Hang the facepiece from the optional neck strap.
9. The regulator can be detached from the facepiece until needed. To detach the regulator from the facepiece:
 - a) Place your right hand over the cover with your thumb on the lock tab.
 - b) Pull the lock tab toward the cover and rotate the regulator 1/4 turn clockwise (viewed from inside of facepiece).
 - c) When the red purge valve is in the 12 o'clock position remove regulator from the facepiece.
 - d) The regulator can be stored in the optional regulator holder on the waist belt.

Proceed to the **FACEPIECE DONNING PROCEDURES** section of this instruction.

WARNING

IF THE END OF SERVICE INDICATOR BELL ALARM DOES NOT ACTUATE AS DESCRIBED IN THIS INSTRUCTION, DO NOT USE THE RESPIRATOR. REMOVE THE RESPIRATOR FROM SERVICE AND TAG IT FOR REPAIR BY AUTHORIZED PERSONNEL. USE OF AN IMPROPERLY OPERATING END OF SERVICE INDICATOR BELL ALARM MAY RESULT IN SERIOUS INJURY OR DEATH.

CAUTION

OVERTIGHTENING THE CYLINDER VALVE MAY CAUSE DAMAGE THAT COULD RESULT IN LEAKAGE OF AIR FROM THE CYLINDER. USE NO TOOLS TO CLOSE THE CYLINDER VALVE.

**USE OF RESPIRATOR
CONTINUED ON NEXT PAGE...**

USE OF RESPIRATOR CONTINUED...

FACEPIECE DOWNING PROCEDURES

Before use of the respirator, the user must read and practice the procedures for donning, use, and termination of use. The user must be familiar with and practice the prescribed donning, leak test, use, and termination of use procedures prior to respirator use. Follow the donning instructions for the model facepiece you have.

The DOWNING INSTRUCTIONS for FOUR STRAP full facepieces (such as the AV-2000, AV-3000, Scott-O-Vista, and the Weld-O-Vista) and the FIVE STRAP full facepieces (such as the AV-3000 SureSeal) are included in this instruction.

The respirator MUST NOT be worn when conditions prevent a good face to facepiece seal. Such conditions include but are not limited to:

- long hair at the forehead or the side of the face that interferes with the sealing surface or gets caught in the head harness buckles,
- facial hair such as growth of beard or sideburns, or low hairline that crosses or interferes with the sealing surface,
- thick or protruding hairstyles such as pony tails or buns that interfere with the smooth and close fit of the head harness to the head,
- temple pieces on corrective glasses,
- a skull cap that projects under the facepiece,
- excessive use of cosmetics including moisturizers, make-up, or after shave,
- the absence of one or both dentures,
- weight loss or weight gain since last fit testing,
- facial scarring,
- anything else which interferes with the face to facepiece seal or the fit of the head harness to the head.

Periodically repeating the fit testing is required to identify any physical changes of the user (such as those listed above) which could affect the fit of the facepiece.

NOTE

IF THE STYLE FULL FACEPIECE RESPIRATOR MASK IS BEING DOWNING FOR THE FIRST TIME OR IF THIS IS THE FIRST TIME A PARTICULAR STYLE FACEPIECE IS TO BE USED, REFER TO THE APPROPRIATE STEPS IN THE FACEPIECE FITTING SECTION OF THIS INSTRUCTION. DURING TRAINING, THE USER MUST DETERMINE THE LEVEL OF TIGHTNESS OF THE HEAD HARNESS REQUIRED TO PROVIDE THE BEST SEAL AND MOST SECURE FIT.

If the facepiece is to be used with a hood, refer to the donning instructions provided with the hood. For other head gear that will cover the facepiece head harness and/or hood, don the facepiece/hood first, then don the other head gear.

To don the facepiece and begin use of respirator, proceed as follows:

WARNING

RESPIRATORS SHALL NOT BE WORN WHEN CONDITIONS PREVENT A GOOD FACE SEAL. SUCH CONDITIONS MAY INCLUDE, BUT ARE NOT LIMITED TO, GROWTH OF BEARDS, SIDEBURNS, FACIAL HAIR OR LOW HAIRLINE THAT CROSSES OR INTERFERES WITH THE SEALING SURFACE, THICK OR PROTRUDING HAIRSTYLES SUCH AS PONY TAILS OR BUNS THAT INTERFERE WITH THE SMOOTH AND CLOSE FIT OF THE HEAD HARNESS TO THE HEAD, A SKULL CAP THAT PROJECTS UNDER THE FACEPIECE, TEMPLE PIECES ON CORRECTIVE EYE GLASSES, EXCESSIVE USE OF COSMETICS INCLUDING MOISTURIZERS, MAKE-UP, OR AFTER SHAVE, OR ANYTHING ELSE WHICH INTERFERES WITH THE FACE TO FACEPIECE SEAL. ALSO, THE ABSENCE OF ONE OR BOTH DENTURES CAN SERIOUSLY AFFECT THE FIT OF A FACEPIECE. USE OF AN IMPROPERLY FITTED FACEPIECE MAY LEAD TO EXPOSURE TO THE HAZARDOUS ATMOSPHERE WHICH COULD RESULT IN SERIOUS INJURY OR DEATH.

DONNING THE FOUR STRAP FACEPIECE

(including: AV-2000, AV-3000, Scott-O-Vista, and Weld-O-Vista)

1. Adjust the head straps to their full outward position.
2. Hold the facepiece in one hand and hold the head harness by the strap at the base of the head net.
3. Place the facepiece on the face with chin properly located in the chin pocket while pulling the head harness over the top of the head. Verify that no hair or clothing is interfering with the face to facepiece seal. See FIGURE 7-A.
4. Tighten the neck straps by pulling the two lower strap ends toward the rear of the head. See FIGURE 7-B.
5. Stroke the head harness net down the back of the head using one or both hands. Verify that the head harness is lying flat against the back of the head. Retighten the neck straps. See FIGURE 7-C.

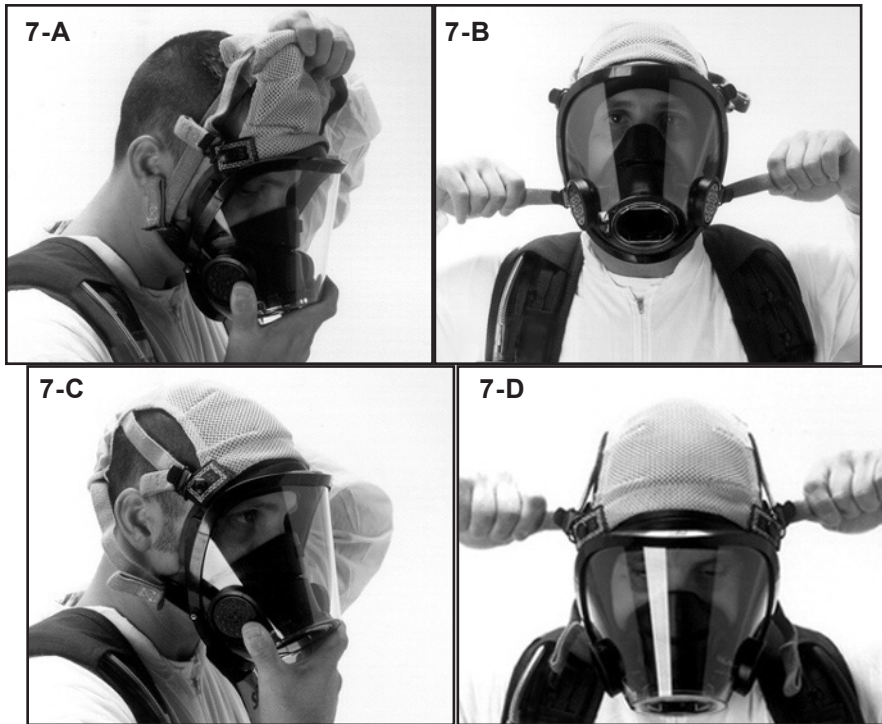

**FIGURE 19
DONNING THE FOUR STRAP FACEPIECE**

6. Tighten the two temple straps. Adjust the temple straps by pulling the two temple strap ends toward the back of the head. Overtightening may cause discomfort. See FIGURE 7-D.
7. Retighten the neck straps if required.
8. Refer to the **DONNING PROBLEMS** section of this instruction.

**USE OF THE RESPIRATOR
CONTINUED ON NEXT PAGE...**

NOTE

ENSURE THAT THE CHIN IS PROPERLY LOCATED IN THE CHIN POCKET OF THE FACEPIECE THROUGHOUT THE DONNING PROCESS.

WARNING

FAILURE TO DON THE FACEPIECE AND/OR FAILURE TO ADJUST THE HEAD HARNESS AS DESCRIBED IN THIS INSTRUCTION MAY RESULT IN A POOR FACE TO FACEPIECE SEAL OR MAY RESULT IN THE FAILURE OF THE FACE TO FACEPIECE SEAL DURING USE. A POOR OR FAILED FACE TO FACEPIECE SEAL MAY REDUCE THE DURATION OF USE OF THE RESPIRATOR AND/OR EXPOSE THE USER TO THE ATMOSPHERE THE RESPIRATOR IS INTENDED TO PROTECT AGAINST RESULTING IN SERIOUS INJURY OR DEATH.

NOTE

VERIFY THAT THE TOP CENTER PORTION OF THE HEAD HARNESS IS POSITIONED OVER THE CROWN OF THE HEAD.

USE OF RESPIRATOR CONTINUED...

DONNING THE FIVE STRAP AV-3000 SURESEAL FACEPIECE

1. Adjust the head straps to the full outward position.



**FIGURE 8-A
ADJUST HEAD STRAPS OUT**

2. Hold the facepiece in one hand while holding the head harness up and out of the way with other hand. If so equipped, use the Head Harness Pull Tab on the bottom rear of the head harness



**FIGURE 8-B
HARNESS OUT OF WAY**

3. Place the facepiece centered on the face with the chin properly positioned in the chin cup. Verify that no hair or clothing is interfering with the face to facepiece seal. Hold the facepiece in place with the chin properly located in the chin cup throughout the donning process.



**FIGURE 8-C
CHIN IN CHIN POCKET**

NOTE
ENSURE THAT THE CHIN IS PROPERLY LOCATED IN THE CHIN POCKET OF THE FACEPIECE THROUGHOUT THE DONNING PROCESS.

4. Stroke the head harness over the head and ensure that straps are lying smooth and flat against the head and neck with no twists. Verify the head harness is centered and properly located at the back and base of the head. Maintain the head harness in this position.



**FIGURE 8-D
HEAD HARNESS POSITION**

NOTE
VERIFY THAT THE TOP CENTER PORTION OF THE HEAD HARNESS IS POSITIONED OVER THE CROWN OF THE HEAD.

5. While holding the facepiece in place with one hand, tighten the neck straps evenly one at a time by pulling each neck strap end toward the rear of the head. Alternate hands to maintain the facepiece position on the face.



**FIGURE 8-E
HOLD AND TIGHTEN**

6. Verify the proper location of the face in the facepiece and the chin in the chin cup. While still holding the facepiece in place with one hand, tighten the temple straps evenly one at a time by pulling each temple strap end toward the rear of the head. Alternate hands to maintain the facepiece position on the face.



**FIGURE 8-F
HOLD AND TIGHTEN**

7. Verify the proper location of the face in the facepiece and the chin in the chin cup. Tighten the forehead strap last by pulling the forehead strap toward the back of the head. Do not overtighten the forehead strap.



**FIGURE 8-G
TIGHTEN FOREHEAD STRAP**

8. Verify that the head harness is centered on the crown of the head and lying flat against the back of the head. Verify the proper location of the face in the facepiece and the chin in the chin cup and retighten all straps as needed.



**FIGURE 8-H
HEAD HARNESS
MUST BE FLAT AND CENTERED**

NOTE

ENSURE THAT THE CHIN IS PROPERLY LOCATED IN THE CHIN POCKET OF THE FACEPIECE THROUGHOUT THE DONNING PROCESS.

**USE OF RESPIRATOR
CONTINUED ON NEXT PAGE...**

USE OF RESPIRATOR CONTINUED...

- Stroke the head harness down the back of the head and make sure the net is centered on your head. If necessary, adjust the head harness net to the center of the crown of the head.



CENTER HEAD HARNESS ON THE CROWN OF THE HEAD

FIGURE 8-I

- Verify the proper location of the face in the facepiece and the chin in the chin cup. Retighten the straps if required. All straps must be snug and the facepiece should feel secure.



FIGURE 8-J
RETIGHTEN IF REQUIRED

- Refer to the **DONNING PROBLEMS** section of this instruction.

NOTE

VERIFY THAT THE TOP CENTER PORTION OF THE HEAD HARNESS IS POSITIONED OVER THE CROWN OF THE HEAD.

NOTE

VERIFY THAT THE TOP CENTER PORTION OF THE HEAD HARNESS IS POSITIONED OVER THE CROWN OF THE HEAD.

DONNING PROBLEMS

1. Perform a personal check of the Facepiece and Head Harness and address any donning problems. OSHA standard 29 CFR 1910.134 requires teams of at least two people for situations where this type of equipment is used. Have your partner help you verify the facepiece is donned properly.

Possible problems include:

- a) Head Harness Strap twisted,
- b) Head Harness off-center or not flat against the head,
- c) Head Harness too high on the head,
- d) Hair or clothing in the face seal,
- e) Face seal rolled over inside the facepiece rather than flat against the face
- f) Facepiece is sitting too low on the face as evidenced by pressure on the forehead or the facepiece making contact with the throat area permitting a break in the seal.

The illustrations below depict the AV-3000 SureSeal, but similar conditions can occur with the AV-2000 or AV-3000 facepiece as well.

WARNING

IF ANY DONNING PROBLEMS ARE FOUND, REMOVE THE FACEPIECE AND RE-DON IT CORRECTLY. USE OF AN IMPROPERLY DONNED FACEPIECE MAY LEAD TO EXPOSURE TO THE HAZARDOUS ATMOSPHERE WHICH COULD RESULT IN SERIOUS INJURY OR DEATH.



**HARNES STRAP
TWISTED**



**HEAD HARNESS
OFF CENTER**

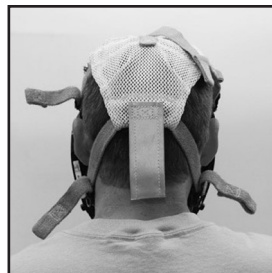

**HEAD HARNESS
TOO HIGH**



**FACE SEAL
ROLLED OVER**



**FACEPIECE
TOO LOW**

**FIGURE 9
DONNING PROBLEMS**

If any donning problems are found, remove the facepiece and re-don the facepiece correctly.

2. Proceed to BEGIN USE OF THE RESPIRATOR as instructed below.

**USE OF RESPIRATOR
CONTINUED ON NEXT PAGE...**

BEGIN USE OF THE RESPIRATOR

1. If regulator is not attached to facepiece, be sure the regulator gasket is in place around the outlet port of the regulator and not damaged.
2. To attach the regulator to the facepiece, hold the regulator with the red purge valve in the 12 o'clock position, align the two flats of the outlet port with corresponding flats in the facepiece port and insert. Rotate the regulator counterclockwise (viewed from inside of facepiece) so that the red purge valve knob is situated on the left side of the facepiece. The lock tab on the mask-mounted regulator will lock into the facepiece retainer with a "click". When properly engaged, the regulator will not rotate.
With facepiece sealed to face, inhale sharply to actuate respirator. Air will then be supplied during inhalation.

NOTE

IF AIR IS NOT SUPPLIED ON FIRST INHALATION, CHECK THAT CYLINDER VALVE IS OPEN, REMOTE GAUGE INDICATES PRESSURE IN CYLINDER AND FACEPIECE IS SEALED TO FACE.

3. **NEGATIVE PRESSURE LEAK TEST** – Close cylinder valve by simultaneously pushing in on cylinder valve knob and rotating it clockwise. Breathe on respirator until airflow stops. The bell alarm will actuate, then stop. Inhale slowly and hold your breath momentarily. No leakage of air shall be detected and the facepiece shall be drawn slightly to the face. Open cylinder valve fully and breathe normally.
4. If the environment is suitably quiet, leakage from the facepiece can also be detected by listening for a flow of air while holding your breath. Inhale and hold your breath momentarily after donning the facepiece. Do not depress air saver switch. Air should not be heard flowing into the facepiece from the regulator and no flow of air shall be detected outward from the facepiece.

NOTE

IF LEAKAGE OF AIR IS DETECTED DURING EITHER OF THE ABOVE PROCEDURES, DEPRESS THE AIR SAVER/DONNING SWITCH ON THE TOP OF THE REGULATOR, DOFF THE FACEPIECE AND REPEAT DONNING STEPS 1 THROUGH 8 ABOVE. IF LEAKAGE PERSISTS, DO NOT USE THE RESPIRATOR.

5. Proceed with use of respirator in accordance with your respiratory protection program.

EVERY ENTRY INTO A CONTAMINATED OR UNKNOWN ATMOSPHERE SHOULD BE PLANNED TO ENSURE THAT THERE IS SUFFICIENT AIR SUPPLY TO ENTER, CARRY OUT THE TASKS REQUIRED AND RETURN TO A SAFE BREATHING AREA. THE USER SHOULD CHECK THE REMOTE READING PRESSURE GAUGE ON THE SHOULDER STRAP PERIODICALLY TO DETERMINE THE RATE OF AIR CONSUMPTION. IN ANY EVENT, THE USER MUST BE CERTAIN TO ALLOW SUFFICIENT AIR FOR EGRESS FROM THE CONTAMINATED AREA. IF ENTRY IS ATTEMPTED AFTER THE AIR HAS BEEN PARTIALLY CONSUMED (CYLINDER LESS THAN FULL), THE USER MUST BE CERTAIN THAT THE REMAINING AIR WILL BE SUFFICIENT FOR SAFETY.

Leave the contaminated or unknown atmosphere immediately if the bell alarm actuates and, in a safe area, determine cause of alarm. When air supply has been depleted, replace cylinder following CYLINDER REPLACEMENT PROCEDURE.

WARNING

WHEN THE BELL ALARM ACTUATES IT WARNS THE USER THAT APPROXIMATELY 25% OF THE FULL PRESSURE REMAINS IN THE CYLINDER (THAT IS, APPROXIMATELY 3/4 OF THE TOTAL AIR SUPPLY HAS BEEN USED). IN THIS EVENT, LEAVE THE CONTAMINATED AREA AT ONCE. IN AREAS WHERE MORE THAN ONE RESPIRATOR IS BEING USED, YOU MAY IDENTIFY YOUR OWN ALARM BY SENSING THE VIBRATIONS THROUGH YOUR BACKFRAME.

TERMINATION OF USE

To doff the facepiece (i.e., remove the facepiece and terminate respiratory protection), proceed as follows:

1. Leave contaminated area or be certain that respiratory protection is no longer required. Decontamination may be required by your respiratory protection program.
2. Loosen the neck straps by simultaneously lifting the lower buckle release levers outward (away from the head) and lifting facepiece away from face. The buckle release levers are the "U-shaped" extensions of the facepiece buckle assemblies.

NOTE

THE USER MAY FIND IT MORE COMFORTABLE TO FIRST RELIEVE TENSION ON THE UPPER STRAP BY LIFTING THE UPPER BUCKLE RELEASE LEVERS.

3. To stop the flow of air from the facepiece, fully depress the air saver/donning switch on top of the regulator and release.

NOTE

OPERATION OF THE AIR SAVER/DONNING SWITCH IS INTENDED TO PREVENT A FREE FLOW OF AIR AND THE DEPLETION OF THE AIR SUPPLY WHEN THE FACEPIECE IS DOFFED. WITH THE AIR SAVER/DONNING SWITCH ACTIVATED, THE PURGE VALVE AND BELL ALARM WILL FUNCTION NORMALLY. IF THE PURGE VALVE HAS BEEN ADJUSTED TO PRODUCE A FLOW, OR IF THE BELL ALARM IS IN OPERATION, THE AIR WILL CONTINUE TO BE DEPLETED.

4. Remove the facepiece by pulling it up and over the head.

NOTE

IF THE RESPIRATOR IS NOT GOING TO BE USED FOR A PERIOD OF TIME, CLOSE THE CYLINDER VALVE.

5. To resume use of the respirator, repeat the facepiece donning procedure (see USE OF RESPIRATOR Section).
6. When respirator operations are completed and only when in a safe breathing area, check that the cylinder valve is closed, and vent the residual air from the respirator by opening the purge valve. After waiting until the air flow stops, close the purge valve. Loosen shoulder straps by depressing the thumb tabs on ends of shoulder strap buckles and release waist belt by either simultaneously squeezing top and bottom releases if equipped with a side release waist belt buckle or depressing center button if equipped with center release buckle. Remove the unit from your back. Proceed in accordance with the requirements of your respiratory protection program for service of the respirator. The respiratory protection program should include procedures for replacement of the cylinder with a fully charged cylinder (see CYLINDER REPLACEMENT Section) and for carrying out the instructions in STANDBY INSPECTION, CLEANING AND STORAGE section for respirator and accessories.

CAUTION

FAILURE TO RELEASE TENSION ON NECK STRAPS BEFORE REMOVING FACEPIECE MAY CAUSE PREMATURE WEAR OR DAMAGE TO STRAPS AND/OR FACEPIECE ASSEMBLY.

WARNING

IF AIRFLOW FROM THE REGULATOR CANNOT BE STOPPED BY DEPRESSING THE AIR SAVER/DONNING SWITCH, IMMEDIATELY CLOSE THE CYLINDER VALVE TO PREVENT DEPLETION OF THE AIR REMAINING IN THE CYLINDER. LOSS OF BREATHING AIR MAY RESULT IN REDUCED DURATION OF THE RESPIRATOR WHICH COULD LEAD TO SERIOUS INJURY OR DEATH.

WARNING

DO NOT ALLOW RESPIRATOR TO DROP FROM BODY WHEN REMOVING. DROPPING OF THE RESPIRATOR MAY CAUSE DAMAGE TO THE RESPIRATOR THAT MAY LEAD TO A MALFUNCTION WHICH COULD RESULT IN INJURY OR DEATH.

WARNING

IF RESPIRATOR USE IS RESUMED AFTER THE AIR HAS BEEN PARTIALLY CONSUMED (CYLINDER LESS THAN FULL), YOU MUST BE CERTAIN THAT THE REMAINING AIR WILL BE SUFFICIENT FOR YOUR SAFETY. (SEE STEP 13 IN USE OF RESPIRATOR SECTION.) USE OF A RESPIRATOR WITHOUT A SUFFICIENT SUPPLY OF BREATHING AIR MAY RESULT IN SUDDEN TERMINATION OF BREATHING AIR RESULTING IN SERIOUS INJURY OR DEATH.

CAUTION

OVERTIGHTENING THE CYLINDER VALVE MAY CAUSE DAMAGE THAT COULD RESULT IN LEAKAGE OF AIR FROM THE CYLINDER. USE NO TOOLS TO CLOSE THE CYLINDER VALVE.

CAUTION

FAILURE TO RELEASE TENSION ON SHOULDER STRAPS BEFORE REMOVING RESPIRATOR MAY CAUSE PREMATURE WEAR OR DAMAGE TO STRAPS AND/OR RESPIRATOR ASSEMBLY.

CAUTION

DO NOT LEAVE THE CYLINDER VALVE OPEN WHEN THE RESPIRATOR IS NOT IN USE. OVER TIME, THE CYLINDER MAY LOSE PRESSURE AND HAVE INSUFFICIENT BREATHING AIR WHEN NEEDED.

EMERGENCY OPERATION

The respirator is automatic in function requiring only the opening of the cylinder valve and the proper donning of the facepiece to place into use and the closing of the cylinder valve at the end of use. In the event of a malfunction or a suspected malfunction, implement the appropriate emergency procedure listed below:

1. Should the bell alarm actuate during use, and before the air supply is depleted to approximately 25% of full capacity, the reducer may have failed. LEAVE THE CONTAMINATED AREA AT ONCE ON ACTUATION OF BELL ALARM.
2. Should the air supply be partially or completely cut off during use, or if you are unable to start the flow of air automatically, fully open the purge valve (red knob on regulator) by turning it counterclockwise, (pointer on knob downward). LEAVE THE CONTAMINATED AREA AT ONCE AFTER OPENING THE PURGE VALVE.
3. Should the air supply begin to flow freely into facepiece, fully open the purge valve (red knob on regulator) by turning it counterclockwise (pointer on knob downward), partially close the cylinder valve by pushing in and rotating clockwise to regulate the flow of air to satisfy the requirements of the user. Do not close the cylinder valve completely. LEAVE THE CONTAMINATED AREA AT ONCE AFTER PARTIALLY CLOSING CYLINDER VALVE.
4. In the unlikely event of the blockage of air flow or sudden and complete loss of the system air supply such that there is total irreversible loss of respiratory protection, LEAVE THE CONTAMINATED AREA AT ONCE USING ALL PRECAUTIONS AND FOLLOW EMERGENCY PROCEDURES PRESCRIBED BY USER ESTABLISHED RESPIRATORY PROTECTION PROGRAM.

If the above procedures are implemented during use, REMOVE THE RESPIRATOR IN A SAFE AREA, tag the respirator and hold it for service and repair by Authorized Personnel.

WARNING

THESE EMERGENCY OPERATION PROCEDURES ARE FOR EMERGENCY USE ONLY. THEY ARE MEANT TO SUPPLEMENT, NOT REPLACE, THE EMERGENCY PROCEDURES PRESCRIBED BY YOUR RESPIRATORY PROTECTION PROGRAM. IF ANY OF THESE PROCEDURES MUST BE USED, LEAVE THE CONTAMINATED AREA IMMEDIATELY. USE OF THESE PROCEDURES WILL INCREASE THE RATE OF CONSUMPTION OF THE AIR SUPPLY WHICH MAY RESULT IN SUDDEN TERMINATION OF AIR SUPPLY WHICH MAY CAUSE SERIOUS INJURY OR DEATH.

WARNING

THE AIRFLOW THROUGH THE RESPIRATOR WHEN THE PURGE VALVE IS OPEN CAN EXCEED 200 LITERS PER MINUTE. WHEN USING EMERGENCY PROCEDURE #2, THE AIR SUPPLY MAY BE CONSERVED AND THE AIRFLOW REDUCED BY PARTIALLY CLOSING THE PURGE VALVE. FAILURE TO LEAVE THE CONTAMINATED AREA AFTER THE PURGE VALVE HAS BEEN OPENED MAY RESULT IN SUDDEN TERMINATION OF AIR SUPPLY LEADING TO SERIOUS INJURY OR DEATH.

WARNING

EMERGENCY PROCEDURE #3 IS THE ONLY TIME THE RESPIRATOR MAY BE OPERATED WITH THE CYLINDER VALVE LESS THAN FULLY OPENED. FAILURE TO LEAVE THE CONTAMINATED AREA AFTER THE PURGE VALVE HAS BEEN OPENED OR COMPLETE CLOSURE OF THE CYLINDER VALVE MAY RESULT IN SUDDEN TERMINATION OF AIR SUPPLY LEADING TO SERIOUS INJURY OR DEATH.

LOW TEMPERATURE OPERATION

The respirator is NIOSH approved for use in temperatures to -25°F / -32°C . For temperatures below 32°F / 0°C , approval requires use of a Nose cup Assembly.

Respirators intended for routine use and respirators not routinely used but kept for emergency use should be located in areas where the temperature is maintained above freezing (32°F / 0°C). Where it is expected that the respirator will be used in ambient temperatures near or below freezing, the respirator shall be equipped with a Nose cup Assembly to reduce the formation of vision impairing mist or ice on the interior of the facepiece vision area. A Nose cup Assembly may be added to the SCOTT-O-VISTA full facepieces.

If a respirator may be unavoidably kept at a temperature below freezing before the next use, special care **MUST** be exercised to be certain that all components of the respirator are **THOROUGHLY DRIED** after cleaning and before storage. Whenever use of the respirator is anticipated in areas at or below freezing, the facepiece, regulator, and connection hoses **MUST** be protected against exposure to water during storage.

If a respirator must be kept at a temperature below freezing and it is not possible to bring it to room temperature before it is used, do not exhale into the facepiece until the facepiece is completely donned and properly fitted against the face.

WARNING

USE OF THIS RESPIRATOR IN TEMPERATURES AT OR BELOW FREEZING, 32°F / 0°C , WITHOUT FOLLOWING THE LOW TEMPERATURE OPERATION INSTRUCTIONS MAY RESULT IN OBSCURED VISION DUE TO FOGGING AND/OR PARTIAL OR COMPLETE BLOCKAGE OF THE AIRFLOW. IF THIS SHOULD OCCUR, THE AIR SUPPLY MAY BE PARTIALLY OR COMPLETELY CUT OFF AND/OR IT MAY BE DIFFICULT OR IMPOSSIBLE TO SEE THROUGH THE FACEPIECE LENS WHICH COULD RESULT IN SERIOUS INJURY OR DEATH.

WARNING

THE RESPIRATOR MUST BE COMPLETELY DRY BEFORE AND DURING STORAGE. MOISTURE IN THE FACEPIECE OR THE WORKING PARTS OF THE RESPIRATOR, ESPECIALLY WHEN EXPOSED TO FREEZING TEMPERATURES, MAY CAUSE FOGGING OF THE FACEPIECE OR A MALFUNCTION OF THE RESPIRATOR WHICH COULD RESULT IN SERIOUS INJURY OR DEATH.

CYLINDER REPLACEMENT PROCEDURE

To replace the air supply cylinder, leave the contaminated area and be certain that respiratory protection is no longer required. Terminate use of the respirator in accordance with the TERMINATION OF USE Section of this instruction. Verify that the cylinder valve is closed, that residual pressure has been bled from the system with the purge valve, and that the purge valve is closed. Remove respirator or have an assistant perform the following steps:

1. Unthread the pressure reducer hose coupling from the cylinder valve by rotating counterclockwise.
2. Disengage the cylinder latch by pressing on the thumb release while lifting on the end of the latch. See FIGURE 10.

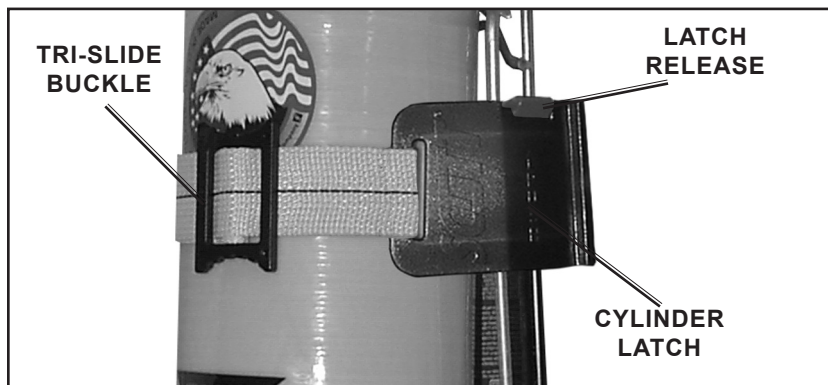

FIGURE 10
CYLINDER LATCH

3. Grasp the cylinder below the retention strap, push the locking tab below the valve, then lift the cylinder free from the bottom hook and remove. See FIGURE 11.

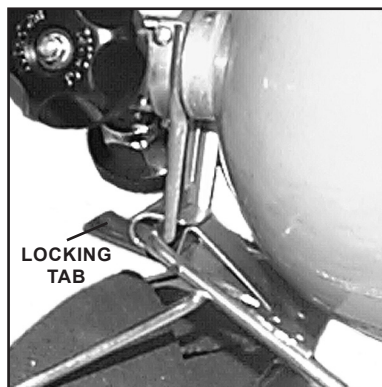

FIGURE 11

4. Replace with a fully charged cylinder of the same pressure rating and valve assembly. Use only 2216 psi cylinder and valve assemblies with 2216 ISCBA respirators and use only 4500 cylinder and valve assemblies with 4500 ISCBA respirators. The hose couplings are designed to allow attachment only of cylinders of the same pressure rating as the pressure reducer used. Attaching a 4500 psi cylinder to a 2216 ISCBA respirator will result in rapid depletion of the air supply when the cylinder valve is opened. Attaching a 2216 psi cylinder to a 4500 ISCBA respirator will result in less than one-half the rated duration for the cylinder.

WARNING

THE USE OF ANY AIR CYLINDER OTHER THAN A CYLINDER AND VALVE ASSEMBLY APPROVED FOR USE WITH THE SPECIFIC SCOTT INDUSTRIAL SCBA RESPIRATOR MODEL BEING SERVICED MAY RESULT IN LOSS OF AIR FROM THE CYLINDER OR IMPROPER OPERATION OF THE RESPIRATOR WHICH COULD CAUSE SERIOUS INJURY OR DEATH.

SEE THE COMPLETE NIOSH APPROVAL LABEL SUPPLIED WITH THESE INSTRUCTIONS FOR CYLINDER AND VALVE ASSEMBLIES APPROVED FOR USE WITH SPECIFIC SCOTT INDUSTRIAL SCBA MODELS.

CAUTION

OVERTIGHTENING THE CYLINDER VALVE MAY CAUSE DAMAGE THAT COULD RESULT IN LEAKAGE OF AIR FROM THE CYLINDER. USE NO TOOLS TO CLOSE THE CYLINDER VALVE.

WARNING

NEVER USE A CYLINDER WITH A DAMAGED CYLINDER VALVE ASSEMBLY OR A CYLINDER VALVE ASSEMBLY WITH DAMAGED THREADS. LEAKAGE MAY OCCUR WHICH COULD CAUSE A LOSS OF BREATHING AIR OR A SUDDEN RELEASE OF HIGH PRESSURE AIR RESULTING IN SERIOUS INJURY OR DEATH.

CAUTION

THE HOSE COUPLING IS DESIGNED TO ALLOW ONLY CYLINDERS OF THE SAME PRESSURE RATING AS THE PRESSURE REDUCER TO BE USED. FAILURE TO REPLACE CYLINDER WITH THE SAME PRESSURE RATED CYLINDER WILL DEplete AIR.

5. Slide the top of the cylinder upward under the strap. Engage the cylinder hanger in the hook at the bottom of the backframe. See FIGURE 12.
6. Inspect the high pressure coupling of the respirator to be certain the coupling gasket is present and undamaged. See FIGURE 12. If the gasket is present and undamaged, align the high pressure coupling with the outlet of the cylinder valve and tighten the hose coupling to the cylinder valve by hand.

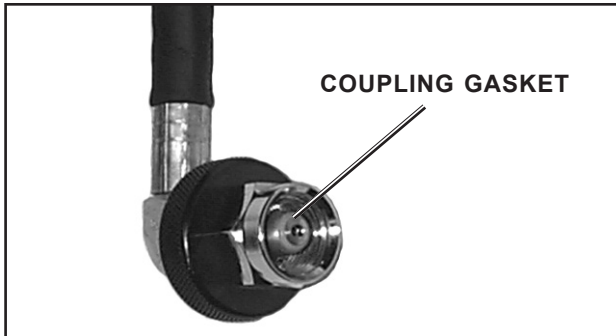

FIGURE 12
HIGH PRESSURE COUPLING GASKET

7. Using the tri-slide buckle, adjust the retention strap to press tightly against the cylinder when the latch assembly is fully engaged. The user should not be able to move retention strap up and down on the cylinder with their fingers when the latch assembly is fully closed.
8. Secure the cylinder in place by pushing the latch toward the backframe to lock the link mechanism and fully engage the latch assembly. See FIGURE 11.

NOTE

ENSURE THAT THE CYLINDER IS SECURELY HELD IN PLACE ON THE BACKFRAME BY THE CYLINDER RETENTION ASSEMBLY. DO NOT USE EXCESSIVE FORCE TO LOCK THE LATCH MECHANISM. IF THE RETENTION STRAP IS TOO TIGHT OR TOO LOOSE, USE THE TRI-SLIDE BUCKLE TO ADJUST THE RETENTION STRAP ENGAGEMENT LENGTH, THEN RE-ATTEMPT TO ENGAGE THE LATCH ASSEMBLY.

The respirator is now ready for reuse.

The removed cylinder shall be inspected and refilled by authorized personnel. Contact SCOTT Safety, for further information.

WARNING

USE OF A RESPIRATOR WITH A MISSING OR DAMAGED NIPPLE SEAL MAY RESULT IN AIR LEAKAGE WHICH MAY REDUCE THE DURATION OF USE AND/OR THE TIME REMAINING AFTER AN END OF SERVICE ALARM ACTUATES OR MAY PREVENT AN END OF SERVICE ALARM FROM ACTUATING. THE USE OF A RESPIRATOR WITH SUCH AN AIR LEAK MAY RESULT IN THE USER OF THE RESPIRATOR BEING EXPOSED TO THE ATMOSPHERE THE RESPIRATOR IS INTENDED TO PROTECT AGAINST.

CAUTION

WRENCHES SHALL NOT BE USED TO TIGHTEN THE HOSE COUPLING. OVER TIGHTENING THE HOSE COUPLING MAY DAMAGE THE COUPLING GASKET.

CAUTION

DO NOT LEAVE THE CYLINDER VALVE OPEN WHEN THE RESPIRATOR IS NOT IN USE. OVER TIME, THE CYLINDER MAY LOSE PRESSURE AND HAVE INSUFFICIENT BREATHING AIR WHEN NEEDED.

CAUTION

DO NOT LEAVE THE CYLINDER VALVE OPEN ON AN "EMPTY" CYLINDER. KEEP THE CYLINDER VALVE CLOSED TO PREVENT MOISTURE OR CONTAMINANTS FROM ENTERING THE CYLINDER.

CAUTION

OVERTIGHTENING THE CYLINDER VALVE MAY CAUSE DAMAGE THAT COULD RESULT IN LEAKAGE OF AIR FROM THE CYLINDER. USE NO TOOLS TO CLOSE THE CYLINDER VALVE.

CLEANING AND STORAGE

Do not attempt any repair or alteration of this respirator beyond the scope of this instruction without proper training.

NOTE

IF DURING USE, THE RESPIRATOR IS SUSPECTED OF BEING CONTAMINATED BY HAZARDOUS SUBSTANCE, THE CONTAMINANT MUST BE IDENTIFIED AND PROPERLY REMOVED OR THE CONTAMINATED COMPONENT(S) MUST BE REPLACED BEFORE NEXT USE. DISPOSE OF THE CONTAMINANTS OR THE CONTAMINATED COMPONENT(S) IN ACCORDANCE WITH APPLICABLE REGULATORY REQUIREMENTS.

After each use of the respirator, clean according to these instructions and perform a REGULAR OPERATIONAL INSPECTION. If any damage is found, remove the respirator from service and tag for repair by authorized personnel.

WARNING

DO NOT ATTEMPT ANY REPAIR OR ALTERATION OF THIS RESPIRATOR BEYOND THE SCOPE OF THIS INSTRUCTION. TRAINING IS REQUIRED FOR FURTHER SERVICE OR REPAIR OF THIS RESPIRATOR. THIS RESPIRATOR MAY SUPPORT LIFE IN HAZARDOUS ATMOSPHERES. FAILURE TO PROPERLY SERVICE THIS RESPIRATOR MAY RESULT IN SERIOUS INJURY OR DEATH.

CLEANING THE RESPIRATOR

1. Damp sponge dirt accumulations from the exterior of the respirator.
2. If respirator has been exposed to potentially hazardous materials, decontaminate in accordance with established procedures.
3. Clean the facepiece and mask mounted regulator as described below.



FIGURE 13

CLEANING THE FACEPIECE

Supplies needed:

- SCOTT recommended sanitizing or disinfecting cleaner such as Wescodyne Plus. This is a dilute iodine solution.
- Drinking (potable) water - running water or in a spray bottle
- Air supply of lubricant free, dry breathing air, maximum 30 psig, for drying

NOTE

PRIOR TO HANDLING OR USE OF ANY OF THE CLEANING AGENTS MENTIONED IN THIS INSTRUCTION, CONSULT THE MANUFACTURER'S MATERIAL SAFETY DATA SHEET (MSDS) FOR PRECAUTIONS AND IMPORTANT INSTRUCTIONS.

NOTE

DO NOT USE A QUATERNARY AMMONIA (AMMONIUM CHLORIDE) TYPE OF CLEANER.

1. With the regulator removed, carefully wash the facepiece assembly with SCOTT recommended cleaner according to the instructions provided with the cleaner and thoroughly rinse in clean water. If the facepiece is heavily soiled, it may be necessary to first wash the facepiece with a solution of mild soap or detergent in warm water (110 °F / 44 °C maximum).

NOTE

A NOSE CUP IS DESIGNED TO BE AN INTEGRAL PART OF THE FACEPIECE AND DOES NOT NEED TO BE REMOVED FOR CLEANING.

2. To sanitize or disinfect the facepiece, use the SCOTT recommended sanitizing or disinfecting cleaner according to the instructions provided with the cleaner. Sanitizing or disinfecting may require a specific contact time of the cleaner prior to rinsing.

NOTE

THE KEVLAR AND NYLON HEAD HARNESSSES ARE MADE OF POROUS MATERIAL. SCOTT RECOMMENDED CLEANER MAY NOT BE EFFECTIVE ON POROUS MATERIAL.

3. Rinse with drinking water using a spray bottle or running water.
4. Shake excess water off of facepiece and then dry with a clean, lint free cloth or gently blow dry with clean, dry breathing air of 30 psig or less pressure. Do not use shop air or any other air containing lubricants or moisture.

**CLEANING AND STORAGE
CONTINUED ON NEXT PAGE...**

CAUTION

CERTAIN CLEANING AND DISINFECTING AGENTS SUCH AS QUATERNARY AMMONIUM COMPOUNDS (AMMONIUM CHLORIDES) MAY CAUSE DAMAGE, DETERIORATION OR ACCELERATED AGING TO PARTS OF THE RESPIRATOR. USE ONLY THE RECOMMENDED CLEANING AND DISINFECTING AGENTS.

WARNING

KEEP ALL SANITIZING OR DISINFECTING CLEANERS OUT OF REACH OF CHILDREN. USE THE CLEANER ONLY IN A MANNER CONSISTENT WITH THE PRODUCT LABELING AND USE INSTRUCTIONS. IMPROPER USE OR HANDLING OF THIS PRODUCT MAY RESULT IN SERIOUS INJURY OR DEATH.

CLEANING AND STORAGE CONTINUED...

CLEANING THE MASK MOUNTED REGULATOR

NOTE

AFTER CLEANING THE REGULATOR, VERIFY THAT ALL MOISTURE HAS BEEN REMOVED FROM THE REGULATOR AS DESCRIBED IN THE **REGULATOR CHECK** SECTION OF THIS INSTRUCTION.

1. Remove the breathing regulator from the facepiece by pulling back on the locking clip and rotating the regulator 1/4 turn clockwise.
2. Remove any obvious dirt from the external surfaces of the regulator using SCOTT recommended sanitizing or disinfecting cleaner with a sponge or soft cloth.
3. Inspect the inside of the regulator assembly through the regulator opening. See FIGURE 14. If excessive dirt or soil is present, forward regulator assembly to SCOTT trained authorized personnel for thorough cleaning.

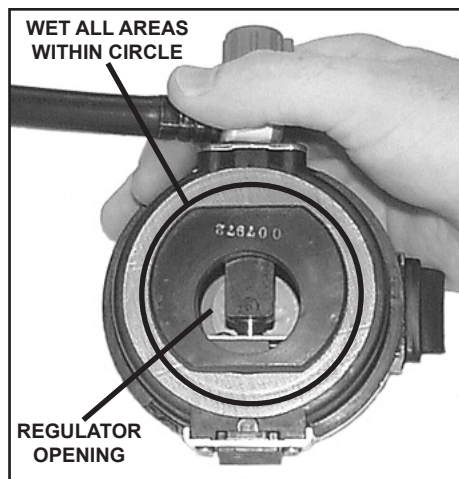

FIGURE 14

4. Depress the donning/air saver switch, close the purge knob by turning fully clockwise. Use the SCOTT recommended sanitizing or disinfecting cleaner in the regulator opening and the immediate area around the opening. See FIGURE 14. Be sure to cover internal components completely.
5. Follow the user instructions for the SCOTT recommended cleaner. A specific contact time may be required for sanitizing or disinfecting before rinsing.
6. Rinse the regulator with drinking water using a spray bottle or gently running tap water.
7. Shake excess water out of regulator. Completely air dry the regulator before use.

NOTE

TO SPEED DRYING OF THE REGULATOR, GENTLY BLOW DRY WITH CLEAN, DRY BREATHING AIR OF 30 PSIG MAXIMUM. **DO NOT USE SHOP AIR OR ANY OTHER AIR CONTAINING LUBRICANTS OR MOISTURE.**

8. If regulator was disconnected from air supply for cleaning, reconnect and open purge valve to remove any moisture from regulator spray bar. Close purge valve.
9. Perform **REGULATOR CHECK** as described below.

REGULATOR CHECK

NOTE

THIS REGULATOR CHECK IS NOT INTENDED TO BE A COMPLETE FUNCTIONAL CHECK OF THE RESPIRATOR. **BEFORE NEXT USE, PERFORM A REGULAR OPERATIONAL INSPECTION AS DESCRIBED IN THESE INSTRUCTIONS.**

1. Check to make sure the respirator cylinder is at least 1/4 full.
2. Verify that the donning/air saver switch is fully depressed.
3. Close the purge knob.
4. Reattach the regulator to the respirator, (if removed for cleaning).
5. Slowly open the cylinder valve at least one (1) full turn.
6. If air flow from the regulator is heard, close the cylinder valve, repeat steps 1, 2 and 3. If air flow is still heard, close the cylinder valve fully, tag unit for repair and remove from service.
7. Open the purge valve and observe the air flow from the regulator spray bar. Droplets of water indicate the regulator is not dry. Dry the regulator according to Step 7 of PROCEDURE FOR CLEANING THE MASK MOUNTED REGULATOR section and repeat the REGULATOR CHECK.

STORAGE OF THE RESPIRATOR

1. Check to ensure gasket is present between facepiece and mask-mounted regulator and is not damaged.
2. Connect the regulator to the facepiece. With the red purge valve in the 12 o'clock position, align the two flats of the outlet port with corresponding flats in the facepiece port and insert. Rotate the regulator counterclockwise (viewed from inside of facepiece) so that the red purge valve knob is situated on the left side of the facepiece. The lock tab on the mask-mounted regulator will lock into the facepiece retainer with a "click." If properly engaged, the regulator will not rotate.
3. To reattach a breathing regulator equipped with a quick disconnect to the respirator, see FIGURE 7.
4. Verify that the respirator is thoroughly dry before placing in storage.
5. Place the clean and dry facepiece in a sealable enclosure to protect until next use. Store in a manner that will not distort the face seals.
6. Place the respirator in the carrying case, protective container, or in a suitable storage location.
7. If any damage or deterioration is noted, remove the respirator from service and tag for repair.
8. Where an SCBA, its spare components or related equipment are stored or carried within a vehicle, such items shall be secured by either a positive mechanical means designed to hold the item in its stowed position, in a compartment with a positive latching door, or in a closed container suitable to transport and contain the SCBA and/or its spare components and associated equipment. The mechanical means of holding the SCBA, its spare components and associated equipment in place, the compartment or the closed container shall be designed to contain the SCBA, its spare components and associated equipment and thereby minimize the possibility of injury to persons in or near the vehicle during movement of the vehicle, especially during rapid deceleration or rapid acceleration of the vehicle, sharp turns or an accident.

WARNING

FOLLOW THE REGULAR OPERATIONAL INSPECTION PROCEDURE EXACTLY. IF THE RESPIRATOR DOES NOT OPERATE AS DESCRIBED OR ANY OTHER OPERATIONAL MALFUNCTION IS NOTED, DO NOT USE THE RESPIRATOR. REMOVE IT FROM SERVICE AND TAG FOR REPAIR BY AUTHORIZED PERSONNEL. FAILURE TO PROPERLY INSPECT THE RESPIRATOR MAY RESULT IN SERIOUS INJURY OR DEATH.

CAUTION

OVERTIGHTENING THE CYLINDER VALVE MAY CAUSE DAMAGE THAT COULD RESULT IN LEAKAGE OF AIR FROM THE CYLINDER. USE NO TOOLS TO CLOSE THE CYLINDER VALVE.

WARNING

PLACING RESPIRATORS IN STORAGE WITHOUT THOROUGHLY DRYING THEM MAY RESULT IN CORROSION OR OTHER DAMAGE WHICH COULD CAUSE A MALFUNCTION OF THE RESPIRATOR. SUCH A MALFUNCTION MAY RESULT IN SERIOUS INJURY OR DEATH.

WARNING

PLACING RESPIRATORS IN STORAGE WITHOUT THOROUGHLY DRYING THEM MAY RESULT IN RESIDUAL MOISTURE WHICH MAY FREEZE IN COLD TEMPERATURES AND CAUSE A MALFUNCTION OF THE RESPIRATOR. SUCH A MALFUNCTION MAY RESULT IN SERIOUS INJURY OR DEATH.

RESPIRATOR MARKINGS

Do not alter or permanently cover over any labels on the SCOTT AIR-PAK SCBA or SCOTT AIR-PAK SCBA cylinder and valve assembly. If user applied identification markings are added to the SCOTT AIR-PAK SCBA or SCBA cylinder and valve assembly, do not obscure any labels supplied on the AIR-PAK SCBA or AIR-PAK SCBA cylinder and valve assembly. Any user applied markings must be applied in such a way as will not weaken or damage the AIR-PAK SCBA or AIR-PAK SCBA cylinder and valve assembly, will not interfere with the proper function of these assemblies and will not add flammable materials to these assemblies.

FIELD LEVEL MAINTENANCE

The respiratory protection program under which this equipment is used may elect to train an individual to perform maintenance beyond the routine cleaning and REGULAR OPERATIONAL INSPECTION of the respirator. For this purpose, the *SCOTT Field Level Maintenance Training Manual* is available on request from SCOTT Health Safety. This manual contains additional maintenance information that can be performed someone with good mechanical ability using standard hand tools. Contact your SCOTT distributor for details. The information in this manual is not as detailed or advanced as that which is available to a SCOTT Authorized Service Center.

PERIODIC TESTING

SCOTT recommends that this respirator be inspected and tested by a SCOTT Authorized Service Center using SCOTT Authorized Test Equipment at least every two years. Heavy use and/or severe service conditions may require more frequent inspection and testing. This recommendation is in addition to all other cleaning and maintenance procedures.

In addition, all air cylinders used with SCOTT respirators must be periodically visually inspected and hydrostatically tested by a licensed cylinder retester. The cylinder inspection and test must be done in accordance with the appropriate US Department of Transportation (DOT) specification or the applicable DOT exemption. See step 2 of the REGULAR OPERATIONAL INSPECTION section of this instruction.

Because this respirator may be used to support human life in a hazardous atmosphere, do not attempt maintenance beyond that described in this instruction or in the *SCOTT Field Level Maintenance Training Manual*. If disassembly or adjustment other than described in this instruction or the *SCOTT Field Level Maintenance Training Manual* is found to be required, the respirator must be serviced by a SCOTT Authorized Service Center in accordance with the appropriate SCOTT Service Manuals. Service by a SCOTT Authorized Service Center can be arranged through your authorized SCOTT distributor or by contacting SCOTT Safety.

RETIREMENT CRITERIA AND CONSIDERATIONS

Retirement criteria and considerations to be determined by SCOTT trained and Certified Overhaul Technicians.

WARNING

APPLYING ANY MARKINGS OR LABELS THAT DAMAGE OR OBSCURE THE EXISTING LABELING MAY VOID THE APPROVAL OF THE CERTIFYING AGENCY BY INTERFERING WITH PROPER IDENTIFICATION OF ASSEMBLIES. IMPROPER IDENTIFICATION OF ASSEMBLIES MAY RESULT IN ERRORS IN MAINTENANCE CAUSING FAILURE OF THE RESPIRATOR WHICH MAY RESULT IN SERIOUS INJURY OR DEATH.

WARNING

DO NOT APPLY ANY MARKINGS OR LABELS THAT DAMAGE OR INTERFERE WITH THE OPERATION OF THE RESPIRATOR. ANY USER APPLIED MARKINGS THAT INTERFERE WITH THE OPERATION OF THE RESPIRATOR MAY CAUSE A FAILURE OF THE RESPIRATOR AND MAY RESULT IN SERIOUS INJURY OR DEATH.

WARNING

MAINTAIN ONLY WITH APPROVED PARTS AND IN ACCORDANCE WITH APPROVED METHODS. THE USE OF NON-SCOTT AUTHORIZED COMPONENTS DURING MAINTENANCE, OR ATTEMPTING MAINTENANCE BEYOND THE SCOPE OF THIS INSTRUCTION WITHOUT THE PROPER TRAINING, EQUIPMENT, AND AUTHORIZATION MAY RESULT IN A FAILURE OF THE RESPIRATOR LEADING TO SERIOUS INJURY OR DEATH.

WARNING

FAILURE TO REGULARLY INSPECT AND MAINTAIN THIS RESPIRATOR AS INSTRUCTED HEREIN MAY RESULT IN A FAILURE OF THE RESPIRATOR LEADING TO SERIOUS INJURY OR DEATH.

CAUTIONS AND LIMITATIONS

- D – AIRLINE RESPIRATORS CAN BE USED ONLY WHEN THE RESPIRATORS ARE SUPPLIED WITH RESPIRABLE AIR MEETING THE REQUIREMENTS OF CGA G-7.1 GRADE D OR HIGHER QUALITY.
- E – USE ONLY THE PRESSURE RANGES AND HOSE LENGTHS SPECIFIED IN THE USER'S INSTRUCTIONS.
- I – CONTAINS ELECTRICAL PARTS WHICH HAVE NOT BEEN EVALUATED AS AN IGNITION SOURCE IN FLAMMABLE OR EXPLOSIVE ATMOSPHERES BY MSHA/NIOSH.
- J – FAILURE TO PROPERLY USE AND MAINTAIN THIS PRODUCT COULD RESULT IN INJURY OR DEATH.
- M – ALL APPROVED RESPIRATORS SHALL BE SELECTED FITTED, USED AND MAINTAINED IN ACCORDANCE WITH MSHA, OSHA AND OTHER APPLICABLE REGULATIONS.
- N – NEVER SUBSTITUTE, MODIFY, ADD OR OMIT PARTS. USE ONLY EXACT REPLACEMENT PARTS IN THE CONFIGURATION AS SPECIFIED BY THE MANUFACTURER.
- O – REFER TO USERS INSTRUCTIONS AND/OR MAINTENANCE MANUALS FOR INFORMATION ON USE AND MAINTENANCE OF THESE RESPIRATORS.
- S – SPECIAL OR CRITICAL USERS INSTRUCTIONS AND/OR SPECIFIC USE LIMITATIONS APPLY. REFER TO INSTRUCTION MANUAL BEFORE DONNING.

S – SPECIAL OR CRITICAL USER'S INSTRUCTIONS

ALL MODELS OF THE SCOTT INDUSTRIAL 4500 PSIG AND 2216 PSIG RESPIRATORS ARE APPROVED FOR RESPIRATORY PROTECTION DURING ENTRY INTO OR ESCAPE FROM OXYGEN DEFICIENT ATMOSPHERES, GASES AND VAPORS, AT TEMPERATURES ABOVE -25 °F / -32 °C.

WHEN USING FACEPIECE P/N 803921-01, 803921-02, OR 803921-03 AT TEMPERATURES BELOW 32 °F / 0 °C ADD OPTIONAL Nose cup ASSEMBLY P/N 802819-01.

SEE LOW TEMPERATURE OPERATION SECTION OF THIS INSTRUCTION MANUAL FOR ADDITIONAL INFORMATION.

ALL MODELS ARE APPROVED ONLY WHEN COMPRESSED AIR RESERVOIR IS FULLY CHARGED WITH AIR MEETING THE REQUIREMENTS OF THE COMPRESSED GAS ASSOCIATION (CGA) SPECIFICATION G-7.1 FOR TYPE 1, GRADE D AIR, OR EQUIVALENT SPECIFICATIONS.

THE CONTAINER SHALL MEET APPLICABLE DOT SPECIFICATIONS.

SEE THE REGULAR OPERATIONAL INSPECTION SECTION OF THE INSTRUCTION MANUAL FOR ADDITIONAL INFORMATION.

TO USE THE DURATION EXTENDING ACCESSORIES, THE SUIT VENTILATION ACCESSORY (HOSE P/N 803801-01 AND STRAP P/N 804082-01) OR THE APPLIANCE ACCESSORY (HOSE P/N 803801-02) THE RESPIRATOR MUST BE EQUIPPED WITH DUAL OUTLET REDUCER.

WHEN USING THE ACCESSORY HOSE ASSEMBLY TO EXTEND DURATION OF USE, REFER TO SCOTT OPERATING INSTRUCTIONS P/N 89167-01 FOR LENGTH OF HOSE AND AIR PRESSURE REQUIRED FOR OPERATION.

THE SUIT VENTILATION HOSE AND THE APPLIANCE HOSE MUST BE DISCONNECTED WHEN NOT UTILIZING THE DURATION EXTENDING SUPPLY HOSE, EXCEPT WHEN THE RESPIRATOR INCLUDES A ONE HOUR RATED CYLINDER (P/N 804222-01). WHEN A ONE HOUR RATED CYLINDER IS USED WITH NO DURATION EXTENDING AIR LINE TO SUPPLY A SUIT VENTILATION ACCESSORY THE RESPIRATOR IS RATED FOR 30 MINUTES DURATION.

THE SCOTT VOICE AMPLIFIER MAY ONLY BE USED WITH A SCOTT FACEPIECE EQUIPPED WITH DUAL VOICEMITTERS.

WARNING

IMPROPER USE OF A RESPIRATOR MAY RESULT IN PERSONAL INJURY OR DEATH. IMPROPER USE INCLUDES, BUT IS NOT LIMITED TO, USE WITHOUT TRAINING, DISREGARD OF THE WARNINGS AND INSTRUCTIONS SUPPLIED WITH THE RESPIRATOR AND ITS ACCESSORIES AND FAILURE TO INSPECT AND MAINTAIN THE RESPIRATOR. READ AND UNDERSTAND THE INSTRUCTION MANUAL AND ANY APPLICABLE ACCESSORY INSTRUCTIONS AND WARNINGS BEFORE ATTEMPTING TO USE A RESPIRATOR.

SCOTT SAFETY

LIMITED WARRANTY ON INDUSTRIAL SCBA

Scott Safety (SCOTT) warrants INDUSTRIAL SCBA (THE PRODUCT) to be free from defects in workmanship and materials for a period of five (5) years from the date of original manufacture by SCOTT. This warranty applies to all components of THE PRODUCT including all accessories and optional equipment purchased and supplied at the time of original sale of THE PRODUCT, EXCEPT electrically operated devices, consumable supplies and carrying cases. SCOTT warrants all electrically operated devices, unused consumable supplies and carrying cases supplied with THE PRODUCT to be free from defects in workmanship and materials for one (1) year from the date of original manufacture by SCOTT. SCOTT's obligation under this warranty is limited to replacing or repairing (at SCOTT's option THE PRODUCT or components shown to be defective in either workmanship or materials.

Only personnel of SCOTT or, when directed by SCOTT, authorized SCOTT agents are authorized to perform warranty obligations. This warranty does not apply to defects or damage caused by any repairs of or alterations to THE PRODUCT made by owner or any third party unless expressly permitted by SCOTT product manuals or by written authorization from SCOTT. To obtain performance under this warranty, and as a condition precedent to any duty of SCOTT, the purchaser must return such products to SCOTT, a SCOTT authorized distributor or a SCOTT authorized service center. Any product returned to SCOTT shall be sent to SCOTT SAFETY (Attn: Warranty Claim Dept.) 4320 Goldmine Road, Monroe, NC 28111.

This warranty does not apply to any malfunction of or damage to THE PRODUCT resulting from accident, alteration, misuse, or abuse.

THIS WARRANTY IS MADE IN LIEU OF ALL OTHER WARRANTIES, EXPRESSED OR IMPLIED INCLUDING, BUT NOT LIMITED TO, ANY IMPLIED WARRANTY OF MERCHANTABILITY OR FITNESS FOR A PARTICULAR PURPOSE. IN ADDITION, SCOTT EXPRESSLY DISCLAIMS ANY LIABILITY FOR SPECIAL, INCIDENTAL OR CONSEQUENTIAL DAMAGES IN ANY WAY CONNECTED WITH THE SALE OR USE OF SCOTT SAFETY PRODUCTS, AND NO OTHER FIRM OR PERSON IS AUTHORIZED TO ASSUME ANY SUCH LIABILITY.



A Tyco International Company

SCOTT SAFETY
Monroe Corporate Center
PO Box 569
Monroe, NC 28111
Telephone 1-800-247-7257
FAX (704) 291-8330
www.scotthealthsafety.com

Scott Safety
ISO 9001 REGISTERED

Printed in USA