

Raychem 910 Series Heat Trace Controller
INSTALLATION, OPERATING AND MAINTENANCE INSTRUCTIONS

Firmware versions up to V3.1x

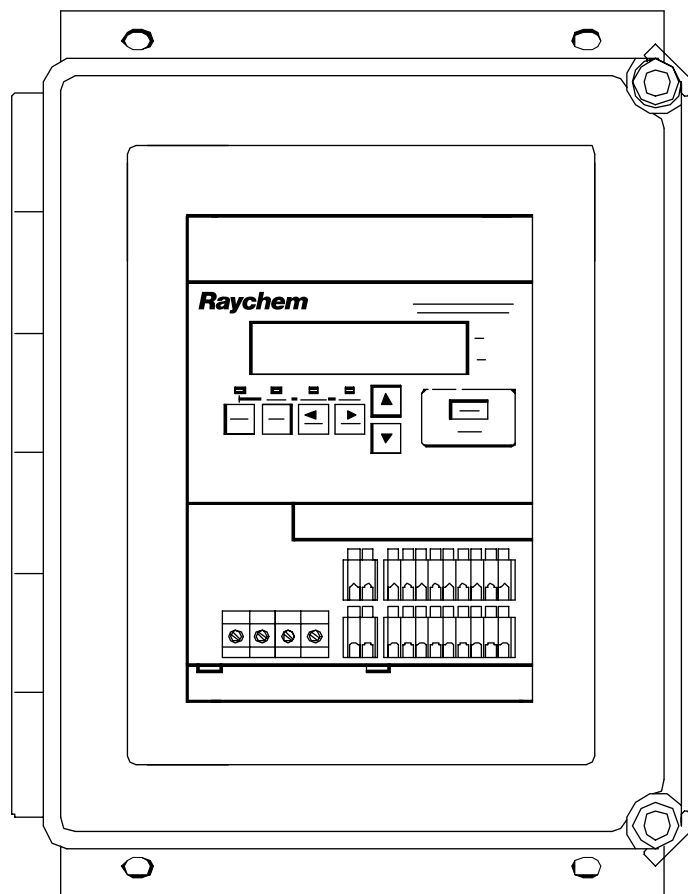

CONTENTS

Certification	4
Limited Warranty.....	4
Warranty Exclusion/Disclaimer	4
Exclusive Remedies	4
Conducted and Radiated Emissions—FCC/DOC Statement of Compliance	4
Section 1—Overview	5
1.1 Introduction	5
1.2 Controllers Covered by this Manual.....	5
1.3 Product Overview.....	5
1.4 Modular Components.....	6
1.5 Controller Assemblies.....	7
1.6 Ordering and Configuration Guide	7
Section 2—Installation and Wiring	9
2.1 Introduction	9
2.2 Initial Inspection	9
2.3 Operator Safety Considerations	9
2.4 Operating Environment	9
2.5 Installation Location.....	9
2.6 Mounting Procedures	10
2.7 Wiring	10
2.8 Initial Power-up.....	13
2.9 Setup for the 910	13
Section 3—Operator Console and Operation	14
3.1 Alphanumeric Display	14
3.2 Keypad	14
3.3 LED Indicators	15
3.4 Operational Basics	15
Section 4—Operator Console Modes	18
4.1 Alarm Mode	18
4.2 Monitor Mode.....	19
4.3 Configure Mode	20
Section 5—Configuration Parameter Details	26
5.1 Introduction	26
5.2 Point Setup Parameters.....	26
5.3 Miscellaneous Setup Parameters.....	33
5.4 Temperature Sensor Alarms Configuration	34
5.5 Other Alarms Configuration	37
5.6 Communications Setup	44
5.7 Operator Console Functions.....	46
Section 6—Monitored Parameter Details	48
6.1 Introduction	48
6.2 Analog Readings.....	48
6.3 Maintenance Data.....	49
Section 7—Control Modes	51
7.1 Introduction	51
7.2 Switch Control Modes.....	51
7.3 Load Shedding Control Mode	53
Section 8—Troubleshooting.....	54
8.1 Operator Checks.....	54
8.2 Common Problem Areas	54

8.3 Common Alarms—What to Look for	56
Section 9—Maintenance	60
9.1 Operator Maintenance.....	60
9.2 Replaceable Parts	60
Appendix A—Specifications	61
Appendix B—Typical Enclosure Dimensions	62
B.1 Standard Fiberglass EMR Assembly #10170-001	62
B.2 Optional Stainless Steel EMR Assembly #10170-003	63
B.3 Standard Fiberglass SSR Assembly #10170-0002	64
B.4 Optional Stainless Steel SSR Assembly #10170-004	65
B.5 910 Series HTC Control Module Dimensions	66
Appendix C—Wiring Diagrams	67
C.1 TS Wiring	67
C.2 Power Wiring.....	67
C.4 Alarm Output Wiring	68
C.5 External Input/Output Port Wiring.....	70
Appendix D—HTC Load Shedding Sequence	71
Appendix E—100 Ω Platinum RTD Table.....	72
DIN 43760—100 Ω Platinum Resistance Temperature (RTD)—0.00385 Ohms/Ohm/°C.....	72
Appendix F—100 Ω Nickel-Iron RTD Table	73
Appendix G—Factory Default Configuration V3.1X	74
910 Series HTC	74

RAYCHEM 910 SERIES HEAT TRACE CONTROLLER

Installation and Maintenance Instructions for Firmware Versions up to and Including V3.1X
Notice: The information contained in this document is subject to change without notice.

CERTIFICATION

Pentair Industrial Heat Tracing Solutions certifies that this product met its published specifications at the time of shipment from the Factory.

LIMITED WARRANTY

This Pentair Industrial Heat Tracing Solutions product is warranted against defects in material and workmanship for a period of 18 months from the date of installation or 24 months from the date of purchase, whichever occurs first. During the warranty period, Pentair Industrial Heat Tracing Solutions will, at its option, either repair or replace products that prove to be defective. For warranty service or repair, this product must be returned to a service facility designated by Pentair Industrial Heat Tracing Solutions. The Buyer shall prepay shipping charges to Pentair Industrial Heat Tracing Solutions and Pentair Industrial Heat Tracing Solutions shall pay shipping charges to return the product to the Buyer. However, the Buyer shall pay all shipping charges, duties, and taxes for products returned to Pentair Industrial Heat Tracing Solutions from another country.

Pentair Industrial Heat Tracing Solutions warrants that the software and firmware designated by Pentair Industrial Heat Tracing Solutions for use with the Raychem 910 Controller will execute its programming instructions properly. Pentair Industrial Heat Tracing Solutions does not warrant that the operation of the hardware, or software, or firmware will be uninterrupted or error-free.

WARRANTY EXCLUSION/DISCLAIMER

The foregoing warranty shall not apply to defects resulting from improper or inadequate maintenance by the Buyer, Buyer-supplied software or interfacing, unauthorized modification or misuse, operation outside of the specifications for the product, or improper installation.

No other warranty is expressed or implied. Pentair Industrial Heat Tracing Solutions disclaims the implied warranties of merchantability and fitness for a particular purpose.

EXCLUSIVE REMEDIES

The remedies provided herein are the buyer's sole and exclusive remedies. Pentair Industrial Heat Tracing Solutions shall not be liable for any direct, indirect, special, incidental, or consequential damages, whether based on contract, tort, or any other legal theory.



CONDUCTED AND RADIATED EMISSIONS—FCC/DOC STATEMENT OF COMPLIANCE

This equipment has been tested and found to comply with the limits for a Class A digital device, pursuant to Part 15 of the FCC rules. These limits are designed to provide reasonable protection against harmful interference when the equipment is operated in a commercial environment. This equipment generates, uses, and can radiate radio frequency energy and, if not installed and used in accordance with the instruction manual, may cause harmful interference to radio communications. Operation of this equipment in a residential area is likely to cause harmful interference, in which case the user will be required to correct the interference at his own expense.

This equipment does not exceed Class A limits for radio emissions as set out in Schedule V to VIII of the Radio Interference Regulations of Communication Canada.

Cet appareil respecte les limites de bruits radioélectriques applicables aux appareils numériques de Classe A prescrites dans la norme sur le matériel brouilleur: "Appareils Numériques," NMB-003 édictée par le Ministre des Communications.

IMPORTANT WARNINGS AND NOTES

The following icons are used extensively throughout this manual to alert you to important warnings  that affect safety and to important notes  that affect the proper operation of the unit.

Be sure to read and follow them carefully.

SECTION 1—OVERVIEW

1.1 INTRODUCTION

This manual provides information pertaining to the installation, operation, testing, adjustment, and maintenance of the Pentair Industrial Heat Tracing Solutions Raychem Model 910 Series Heat Tracing Controller.

Additional copies of this user manual may be ordered separately through your Pentair Industrial Heat Tracing Solutions representative or online at www.thermal.pentair.com using the document number H56873.

1.2 CONTROLLERS COVERED BY THIS MANUAL

This document covers the 910 Series Heat Trace Controllers and its available options. The information coincides with the specific releases of firmware for the 910 product which are listed on the front page. As Pentair Industrial Heat Tracing Solutions releases new firmware to modify or enhance the product significantly, new documentation will accompany these releases. To ensure that you are using the correct documentation for your particular version of controller, please check the firmware version number of the 910 against the version number listed on the front of this manual. This may be displayed using the Operator Console or a communicating device. As subsequent changes are made, supplements to this document will be issued and included in manuals shipped after the firmware is released. Supplements will make specific reference to the operational or functional changes, and are available at www.thermal.pentair.com.

1.3 PRODUCT OVERVIEW

1.3.1 DESCRIPTION

The 910 Series electronic Heat Tracing Controller controls, monitors, and communicates alarms and data for one heating circuit. The ability to install the units in Class 1, Division 2 areas supports direct field installation, if desired. It is available with a solid-state relay (SSR) output for use in hazardous areas or with electromechanical relay (EMR) output for use in ordinary (non-hazardous) areas.

1.3.2 FEATURES

A detailed description of available features may be found in Section V of this manual. Highlights of specific features follow.

Keypad and Alphanumeric Display

A six character alphanumeric LED display provides the operator with large easy to read messages and prompts, eliminating complex and cryptic programming. Six individual keys are provided to quickly access alarming and operational information.

–40°F to 140°F (–40°C to 60°C) Operation

Extended temperature operation permits installation in all but the harshest environments.

Single or Dual Temperature Sensor Inputs

The ability to utilize one or two temperature sensor (TS) inputs allows the selection of one of eight control modes and programming of all temperature parameters.

High and Low Temperature Alarms

High and low temperature alarms are offered for both temperature sensor inputs of each control point.

High and Low Current Alarms

The 910 offers full adjustment of both the high and low alarm points over the entire current measurement range.

Solid State or Electromechanical Relay (EMR) Output

The 910 is available with either a solid-state relay (SSR) or an electromechanical relay (EMR) output switch. With the SSR option, the user may select a time-proportional control algorithm, a simple deadband control mode, or one of two ambient control algorithms. The EMR version always uses either the deadband mode or the proportional ambient contactor mode. Switching device failure alarms are supported for both types of output devices.

Ground Fault Alarm and Trip

Ground Fault (GF) current levels are monitored and may be displayed in milliamps. The availability of the actual ground fault level gives the user the choice of both alarm and trip levels suitable for the particular installation.

Overcurrent Protection

A unique overcurrent protection algorithm greatly reduces the possibility of damage to the circuit or the controller in the event of a temporary overload while allowing for initially high in-rush currents (SSR options only).

Soft Starting

Given the circuit breaker size, the 910 will limit the energy let-through to help prevent nuisance breaker trips due to cable in-rush. This feature makes the controller particularly attractive for use with self-regulating cables (SSR options only).

Minimum/Maximum Temperature Tracking

The controller maintains the minimum and maximum temperature values it has measured since the last reset of these values. This is helpful in determining causes of temperature alarms.

Latching/Non-Latching Temperature Alarms

User selectable non-latching temperature alarms allow the controller to automatically clear the alarm when the condition no longer exists.

High and Low Voltage Alarms

Operating at voltages less than design can cause serious loss of heater output. The alarming of preset voltage deviations ensures availability of sufficient wattage output.

Power-Limiting

The 910 will control the maximum output wattage if the full load power exceeds the specified Maximum Power Setpoint. This feature eliminates the need for low voltage transformers in many applications and can assist in standardization of heating cable types (SSR options only).

Autocycling

The controller will momentarily energize the circuit (for 10 seconds) at a programmable interval. Circuit alarms will be generated at the time of autocycle instead of when the heat is required. This feature eliminates the need for a preventive maintenance program as these tests are performed at regular intervals by the controller.

Temperature Sensor Failure Alarm

Both open and shorted sensors are detected and alarmed by the controller.

Random Start

A startup delay between 0 and 9 seconds ensures that all units do not come on line at the same time.

Full Digital Communications

An optional internal communications interface allows the communication of alarms and analog data to a monitoring system. Industry-standard RS-232 or RS-485 serial communications are available for applications requiring direct interfacing to other devices. The modem version maintains compatibility with legacy products, including the Group Communications Controller (Model 780/GCC-9000). With heat trace data at the user's fingertips, historical trending of temperatures, power consumption, or other parameters are available for analysis and system optimization.

CSA C/US

The 910 Series of controllers are approved for Class I, Division 2, Groups A, B, C, D hazardous locations making them ideal for direct installation in the field. This may save the significant expense of wiring back to a centrally located electrical distribution center.

1.4 MODULAR COMPONENTS

The 910 Series controller is made up of two components. Each component's primary function is described below.

1.4.1 CONTROL MODULE

The 910 Control Module forms the heart of a single heat trace control solution. Each Control Module provides all of the intelligence required to control and monitor one heat trace circuit. It

includes indicators for alarm and output status and an integral Operator Console. An internal connector is provided to plug in an optional communications interface.

The Control Module packaging provides a rugged, vibration-proof design.

Temperature sensor, communications, and alarm control wiring are connected to the lever-operated spring terminals, providing gas-tight, vibration-resistant connections.

A large, easy-to-read alphanumeric display and menu-driven interface eases controller configuration and eliminates the need for an external programmer. Access is available for all monitored parameters, programmed values, and alarm information. Enhanced security is provided by password protection.

Single phase current monitoring, ground fault detection, and voltage monitoring are provided. The 910 Control Module also incorporates a universal power supply, allowing operation directly from 100 to 277 Vac.

1.4.2 COMMUNICATIONS INTERFACE

In applications where the user wishes remote configuration capability, or wants to communicate trace information and/or alarms to another device such as a Group Communications Controller (780 Series/GCC-9000), an optional communications interface may be installed in the Control Module.

A modem version that maintains compatibility with legacy products is available, or other industry-standard interfaces such as RS-232 and RS-485 may be specified.

1.5 CONTROLLER ASSEMBLIES

Two standard assemblies are available and stocked at the Factory:

1. An SSR version for use in ordinary or Class I, Division 2 areas
2. An EMR version for use in ordinary locations only

1.6 ORDERING AND CONFIGURATION GUIDE

Raychem 910 CONTROLLERS – FACTORY INVENTORY

Description	Catalog Number	Part Number	Weight
Raychem 910 controller in an 8" x 10" FRP enclosure with window. 2-pole 30 A EMR. Controls a single circuit with a 2-pole electromechanical relay. (Approved for ordinary areas only)	910*E1FWL*EMR2	10170-001	15
Raychem 910 controller in an 8" x 10" FRP enclosure with window. 2-pole 30 A EMR. Controls a single circuit with a 2-pole electromechanical relay. Includes an isolated 2-wire RS-485 communication option. (Approved for ordinary areas only)	910*E1FWL*EMR2*485	10170-015	15
Raychem 910 controller in an 8" x 10" FRP enclosure with window. 2-pole 30 A 277 V SSR. Controls a single circuit with a 2-pole solid-state relay. (Approved for Class I, Div. 2 areas)	910*E1FWL*SSR2	10170-002	20
Raychem 910 controller in an 8" x 10" FRP enclosure with window. 2-pole 30 A 277 V SSR. Controls a single circuit with a 2-pole solid-state relay. Includes an isolated 2-wire RS-485 communication option. (Approved for Class I, Div. 2 areas)	910*E1FWL*SSR2*485	10170-016	20
Raychem-Raychem Supervisor Software	Raychem Supervisor	10391-002	1

Raychem 910 CONTROLLERS – MADE-TO-ORDER (Contact factory for lead time)

Raychem 910 controller in an 8" x 10" stainless-steel enclosure with window. 2-pole 30 A EMR. Controls a single circuit with a 2-pole electromechanical relay. (Approved for ordinary areas only)	910*E1SW*EMR2	10170-003	20
Raychem 910 controller in an 8" x 10" stainless-steel enclosure with window. 2-pole 30 A EMR. Controls a single circuit with a 2-pole electromechanical relay. Includes an isolated 2-wire RS-485 communication option. (Approved for ordinary areas only)	910*E1SW*EMR2*485	10170-017	20
Raychem 910 controller in an 8" x 10" stainless-steel enclosure with window. 2-pole 30 A 277 V SSR. Controls a single circuit with a 2-pole solid-state relay. (Approved for Class I, Div. 2 areas)	910*E1SW*SSR2	10170-004	25
Raychem 910 controller in an 8" x 10" stainless-steel enclosure with window. 2-pole 30 A 277 V SSR. Controls a single circuit with a 2-pole electromechanical relay. Includes an isolated 2-wire RS-485 communication option. (Approved for Class I, Div. 2 areas)	910*E1SW*SSR2*485	10170-018	25

RTD SENSORS

100-ohm platinum RTD with 10' stainless-steel corrugated sheath	RTD10CS	RTD10CS	1.0
RTD, ambient, cable style	MONI-RTD-200	254741	0.1
C1D1 RTD, -100°F to 900°F, pipe mounted	RTD7AL	RTD7AL	2.0
RTD, -100°F to 900°F, pipe mounted	RTD4AL	RTD4AL	1.2

OPTIONS

Append the following code(s) to the end of the standard Model Code to have the option included at the factory

Option Code	Description
*232	RS-232 communications option (replace *485 with *232)
*MDM	Modem communications option (replace *485 with *MDM)
*ALR	Red LED pilot light
*ALG	Green LED pilot light

Contact your local representative for configurations not listed here.

SECTION 2—INSTALLATION AND WIRING

Caution: Be sure all personnel involved in installation, servicing, and programming are qualified and familiar with electrical equipment, their ratings and proper practices and codes. Multiple voltages and signal levels may be present during the installation, operation, and servicing of this product. Do not power the product until the safety provisions outlined in this section have been observed.

2.1 INTRODUCTION

This section includes information regarding the initial inspection, preparation for use, and storage instructions for the 910 Series Heat Trace Controller.

2.2 INITIAL INSPECTION

Inspect the shipping container for damage. If the shipping container or cushioning material is damaged, it should be kept until the contents of the shipment have been verified for completeness and the equipment has been checked mechanically and electrically. Procedures for configuring and operating the heat trace controller are given in Sections III, IV, and V. If the shipment is incomplete, there is mechanical damage, a defect, or the controller does not pass the electrical performance tests, notify the nearest Pentair Industrial Heat Tracing Solutions representative. If the shipping container is damaged, or the cushioning material shows signs of stress, notify the carrier as well as your Pentair Industrial Heat Tracing Solutions representative. Keep the shipping materials for the carrier's inspection.

2.3 OPERATOR SAFETY CONSIDERATIONS

The standard 910 controller using solid-state relays is suitable for Class 1, Division 2, Groups A, B, C, and D hazardous areas. Hazardous areas are defined by Article 500 of the National Electrical Code and Section 18 of the Canadian Electrical Code. Electromechanical relay (EMR) based assemblies are suitable for use in ordinary (non-hazardous) areas only.

Caution: Some wiring configurations will use more than one power source and all must be de-energized prior to performing any maintenance on a controller circuit.

2.4 OPERATING ENVIRONMENT

The operating environment should be within the limitations specified in the 910 Heat Trace Controller Specifications outlined in Appendix A.

2.5 INSTALLATION LOCATION

The wide ambient operating temperature range of the controller permits installation in most any convenient location. Considerations should include expected atmospheric conditions, accessibility for maintenance and testing, the location of existing conduits and hazardous area rating. Ambient temperature conditions may affect load current ratings.

Caution: Always be sure that the intended location is classified as an area that the product is approved for as defined by Article 500 of the National Electrical Code and/or Part I, Section 18 of the Canadian Electrical Code.

2.6 MOUNTING PROCEDURES

Mounting hole dimensions for the standard enclosures are shown in Appendix B. Conduit entries should be made in the bottom of the enclosure if possible to reduce the possibility of water entry or leakage. Conduit entries must be drilled/punched following the enclosure manufacturers' recommendations. Use bushings suitable for the enclosure type and install such that the completed installation remains waterproof. For nonmetallic enclosures, grounding hubs and conductors must be installed in accordance with Article 501-4(b) of the National Electrical Code and Part I of the Canadian Electrical Code.

The user may want to consider enclosure drain holes in applications where moisture is a problem; drill 0.125" holes in the bottom of the enclosure on both the left and right sides. Two holes reduce the possibility that one will plug and ensures drainage if the enclosure is not perfectly level. Note that drilling holes in the enclosure compromises the NEMA 4 rating.

2.6.1 Controller Installation and Removal

⚠ CAUTION:

Always ensure that the power to the unit is turned off during installation or removal to avoid the risk of injury and damage to the controllers.

⚠ WARNING:

Explosion Hazard! Do not install or remove the control module while the unit is powered.

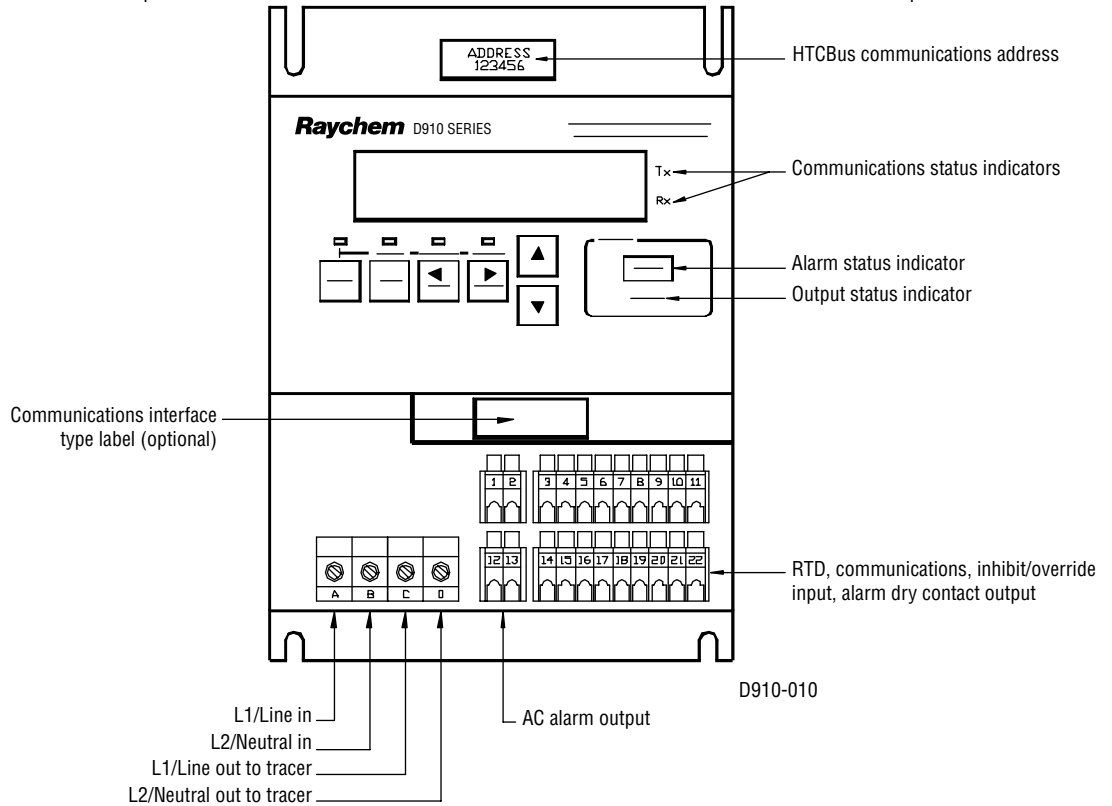

Fig. 2.1 Control module face

2.7 WIRING

Wiring diagrams for typical configurations are included in Appendix C of this manual.

⚠ CAUTION:

Always verify wiring connections before applying power to the controller or connected circuits. To avoid injury or equipment damage, do not install or remove wiring while controller power is on.

To minimize the chance of loose connections, the 910 uses lever-operated, spring-loaded terminals for signal wiring. See Appendix A for allowable wire sizes and recommended insulation strip lengths.

2.7.1 TEMPERATURE SENSOR CONNECTIONS

Use shielded, twisted, three-conductor wire for the extension of RTD leads. The wire size should ensure that the maximum allowable lead resistance is not exceeded. Shields on RTD wiring should be grounded at the controller end only, using the terminals provided.

Temperature Sensors	Terminal No.
Shield	19
TS 1 Source (WHT)	20

TS 1 Sense (WHT)	21
TS 1 Common (RED)	22
Shield	8
TS 2 Source (WHT)	9
TS 2 Sense (WHT)	10
TS 2 Common (RED)	11

2.7.2 ALARM RELAY CONNECTIONS

Two types of alarm relays are provided: one is a programmable dry contact output relay and the other is a line voltage AC relay (Triac). Both may be programmed for N.O., N.C., steady or flashing operation, and are typically used to annunciate an alarm to an external device such as a DCS, PLC, etc.

Notes:

- Both alarm relays are controlled by the 910 using the same signal. The N.O., N.C., and flashing parameter settings affect both the dry contact and the AC alarm relays.
- The dry contact alarm relay is intended to be used for switching low-voltage, low-current signals. Do not use this relay to directly switch line voltages. Ensure that your application stays within the ratings of the relay contacts as defined in Appendix A.

The AC alarm relay alarm relay is typically used to drive a local, external, line-voltage pilot light, etc. Refer to the wiring diagrams in Appendix C for example connection details.

Dry Contact Alarm and Control Signals	Terminal No.
Alarm relay dry contact output	14
Alarm relay dry contact output	15
Ground	4
+12Vdc nom. Out	3

AC Alarm and Control Signals	Terminal No.
L1/Line out	1
L2/Neutral out	2
AC alarm relay	12
AC alarm relay	13

2.7.3 EXTERNAL CONTACT INPUT/OUTPUT

These input terminals are used to implement the inhibit and override features. Refer to Section V of this manual for programming details, and Appendix C for example wiring diagrams.

Miscellaneous Signals	Terminal No.
External input (+)	6
External input (-)	7

2.7.4 COMMUNICATION SIGNAL CONNECTIONS

The communications terminal assignments change based on the type of option installed. If present in a 910 Control Module, the type of communications interface will be identified by a label located on the front of the control module (Figure 2.1).

Communications wiring should use twisted pair, shielded cable. Shields on communications wiring should be grounded at one end only, using the terminals provided.

The following tables define the appropriate signal connections for the various types of interfaces:

RS-485 (2-Wire) Connections

Communication Signal	Terminal No.
Receive/transmit data (+)	16
Receive/transmit data (-)	17
Shield	18

RS-232 (3-Wire) Connections

Communication Signal	Terminal No.
Receive data	16
Transmit data	17
Common	18

Modem Interface Connections

Communication Signal	Terminal No.
Modem	16
Modem	17
Shield	18

2.7.5 POWER CONNECTIONS

All of the power terminals are labeled for easy identification. Do not attempt to use wire sizes that exceed the marked terminal ratings and avoid terminating two wires on the same terminal whenever possible.

Always be sure that all terminals are adequately tightened according to the terminal manufacturer's specification. See Appendix A for allowable wire sizes, recommended insulation strip lengths, and tightening torque. A loose terminal can cause arcing and damage to the terminal or incorrect operation of the controller.



IMPORTANT: Make sure that power terminals are retightened several days after installation. Stranded wire will tend to compress when initially installed; therefore, these terminals should be checked for tightness several times after the system is installed to ensure that a good connection is maintained. Be certain to use the proper size screwdriver for the terminal blocks to minimize the chance of damage to the terminals.

If the controllers are installed in either a metallic or non-metallic enclosure, follow the enclosure manufacturer's recommendations for proper grounding. Do not rely on conduit connections to provide a suitable ground.

Grounding terminals/screws are provided for connection of system ground leads. Proper system grounding is required for safe and correct operation of the controller's protection features.

2.7.6 INPUT POWER

The 910 controller may be powered directly from a 100 to 277 Vac circuit. The wiring terminal assignments are defined below.

Power Connections	Terminal No.
Line/L1 power input	A
Neutral/L2 power input	B
Line/L1 output to trace	C
Neutral/L2 output to trace	D

Wiring diagrams for typical configurations are included in Appendix C.

CAUTION:

Many wiring configurations will use more than one power source and all must be de-energized prior to performing any maintenance on a controller circuit.

2.8 INITIAL POWER-UP

CAUTION:

Before applying power to the controller, ensure that powering the circuit will not damage it if power limiting or the setpoint temperature have not been set correctly. If there is any doubt, the load should be disconnected until the 910 has been suitably programmed for correct and safe operation.

2.8.1 INITIAL CABLE TEST

To minimize the risk of damage to the controller due to a cable fault, the integrity of the heating cable should be verified by:

1. Performing a high voltage insulation test using a “Megger”
2. Using an ohmmeter to ensure that the heating cable is not shorted

These tests must be performed with the controller output disconnected.

Once the cable has been checked, it may be reconnected to the controller and power applied.

2.8.2 RANDOM START DELAY

All 910 Series Control Modules incorporate a RANDOM START-UP DELAY feature, ensuring that all units do not power on at the same time. When power is first applied to a controller, it will hold its output off for a random time (0 to 9 seconds), equal to the last digit of the HTCBUS™ communications address (see Section 5.6.2). Once the start-up delay has timed out, the controller will begin normal operation.

2.9 SETUP FOR THE 910

The 910 may be programmed using the Operator Console, or if a communications option is installed, with an external communicating device. For instructions on the operation of these devices, refer to the corresponding operating manuals. For complete instructions on programming the 910, see the Programming and Configuration Section of this manual.

SECTION 3—OPERATOR CONSOLE AND OPERATION

3.1 ALPHANUMERIC DISPLAY

The console incorporates a six character, fourteen segment plus decimal LED display. Messages and prompts that are greater than six characters long are scrolled, allowing more meaningful, non-cryptic messages to be used.

3.2 KEYPAD

The local keypad consists of six keys that allow you to select the console mode function that you are interested in. For certain keys, the SHIFT key selects an alternate function, as shown by the text above that key.

Key	Function
SHIFT	<ul style="list-style-type: none">• Press to activate a SHIFTed function; the next key pressed uses the alternate (shifted) function• The SHIFT LED illuminates, indicating the next key uses the alternate (shifted) function• Pressing SHIFT again cancels the alternate (shifted) function
TEST [shift ALARM]	<ul style="list-style-type: none">• Turns on tracing for 30 seconds• When prefixed by the SHIFT key, this key switches the console to the Alarm mode
◀ BACK [shift MONITOR]	<ul style="list-style-type: none">• Exits the current menu (or cancels the new setting when editing a parameter)• Moves the cursor to the left when editing an alphanumeric parameter• When prefixed by the SHIFT key, this key switches the console to the Monitor mode
▶ ENTER [shift CONFIG]	<ul style="list-style-type: none">• Selects the item in the display (or accepts the setting when editing a parameter)• Moves the cursor to the right when editing an alphanumeric parameter• When prefixed by the SHIFT key, this key switches the console to the Configure mode
△	<ul style="list-style-type: none">• Moves to the previous item in a menu• Increments the value when editing
▽	<ul style="list-style-type: none">• Moves to the next item in a menu• Decrements the value when editing

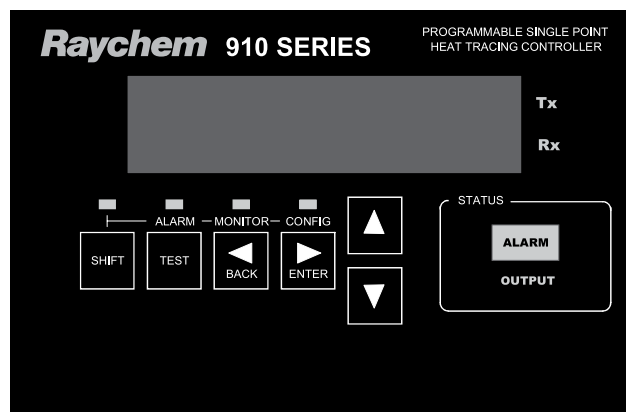

3.3 LED INDICATORS

The console includes eight LED indicators:

Four LEDs indicate the console operating mode (SHIFTed function, ALARM, MONITOR, or CONFIGure modes).

There are two status LEDs which indicate the alarm and control output status of the controller:

1. The output LED, when illuminated steadily, indicates that the output of the controller is turned on and is allowing current to flow into the loadtrace circuit. For SSR versions programmed for proportional modes, a flashing LED indicates that the controller is pulsing its output on and off to maintain the setpoint temperature and/or control the average amount of current/power the tracer uses.
2. The alarm LED will flash (approximately once per second) when the controller has detected an alarm condition.

The two additional LEDs are used to indicate external communications activity and are only used when an optional communications interface is installed. The "Rx" LED flashes to show that the Controller is receiving information via its communications port. The "Tx" LED flashes when the Controller is transmitting information via its communications port.

3.4 OPERATIONAL BASICS

3.4.1 OPERATING MODES

The console operates in one of four modes and is related to the basic function the operator selects.

Mode	Function
Scan	This is the default mode. In this mode, the console sequentially displays load current, temperature, and setpoint readings.
Alarm	Invoked when you press the SHIFT key followed by the ALARM key. This mode allows you to examine or reset any alarms that may exist. The LED above the ALARM key is illuminated while in this mode.
Monitor	Invoked when you press the SHIFT key followed by MONITOR key. In this mode, you may examine any of the controller readings such as temperature, load current, etc. The LED above the MONITOR key is illuminated while in this mode.
Configure	Invoked when you press the SHIFT key followed by CONFIG key. In this mode, you may examine or alter the controller configuration. The LED above the CONFIG key is illuminated while in this mode.

3.4.2 MENUS

Each of the operating modes has a list of data items associated with it. For example, in the Monitor mode you may view temperatures, load current, resistance, ground fault current, voltage, or power information. This collection of data items is referred to as a menu.

Only one menu item may be viewed at a time. The ∇ (\triangle) keys move to the next (previous) item in the menu. When you reach the end of the menu (indicated by ---- END ---), ∇ wraps you to the first item in the menu; conversely, \triangle wraps you to the last item in the menu.

Some of the items within a menu are actually entry points to sub-menus—these entries are indicated with "..." at the end of the message. To enter a sub-menu, press the \triangleright key. To move around in the menu, use the ∇ and \triangle keys move to the next and previous items respectively. The \triangleleft key exits the current menu and returns to the previous menu.



After approximately five minutes of keypad inactivity, the current menu and mode will be exited and the console will revert to the Scan mode.

IMPORTANT: Some menus are dynamic; that is, some items appear or disappear depending on the configuration. For example, if you disable the Low Voltage Alarm, then the corresponding Low Voltage Setpoint is not available and will not be displayed.

3.4.3 CHANGING THE CONFIGURATION

To change the Controller configuration, follow the directions listed below.

- Position the desired parameter (menu item) in the display.
- Press the \triangleright key to initiate an edit session.
- If the console is “locked” you are prompted to enter the passcode.
- The present setting will flash on the display to indicate that you are editing the parameter.
- Use the \leftarrow and \rightarrow keys to change the value.
- The operation of the \triangleright and \leftarrow varies depends on the type of data being editing. See the following sections for details.



IMPORTANT: Once you have initiated an edit session, you must end it before switching to another mode or invoking another function. An edit session ends when you enter a new value (using the \triangleright key) or you back out of it (using the \leftarrow key).

3.4.4 CHANGING A NON-NUMERIC PARAMETER

To change a non-numeric parameter (e.g.: an alarm mask setting), follow the directions below.

- Position the appropriate parameter in the display.
- Press the \leftarrow key to initiate the edit session.
- If the console is “locked” you are prompted to enter the passcode.
- The present setting will flash on the display to indicate that you are editing the parameter.
- Use ∇ or \triangle until the desired value appears in the display.
- Pressing \triangleright saves the new value.
- Pressing \leftarrow ends the edit session without altering the parameter.

3.4.5 CHANGING A NUMERIC PARAMETER

To change a numeric parameter (e.g. the control setpoint), follow the directions below.

- Position the appropriate parameter in the display.
- Press the \triangleright key to initiate the edit session.
- If the console is “locked” you are prompted to enter the passcode.
- The present value is displayed and the last (rightmost) digit blinks.
- The blinking digit identifies the digit that you are editing.
- Use ∇ or \triangle to set the desired value.
- Use \leftarrow or \triangleright to move to a different digit.
- To enter a negative value, scroll to the first (leftmost) digit until a “-” appears in the display.
- Pressing \triangleright while on the last (rightmost) digit saves the new value.
- Pressing \leftarrow while on the first (leftmost) digit ends the edit session without altering the parameter.

3.4.6 PASSCODE PROTECTION

The 910 Series Controller provides a passcode for protection of its configuration. You may view any portion of the configuration with the console “locked”; however, when you attempt to initiate an edit session by pressing \triangleright , you are prompted to enter the passcode. Entering the passcode is just like entering any other numeric value; see Section 3.4.5 “Changing a Numeric Parameter.”

Once the console is “unlocked,” you may edit any configuration parameter. The console will automatically re-lock after approximately five minutes of keypad inactivity, or until the user explicitly locks it.

**IMPORTANT:**

- Setting the programmed passcode to “0” disables passcode protection.
- The console does not have to be unlocked to reset alarms.

3.4.7 FEATURE MODES

There are two types Configuration Menus in the 910 Series Controller.

1. A “Basic” Configuration Menu which only contains seven parameters
2. An “Advanced” Configuration Menu which contains all of the parameters

Both types of Configuration Menus contain a “Feature Mode” parameter which allows the user to select which type of Configuration Menu is most desirable.

3.4.8 QUICK NOTES ON OPERATION

Remember the following basic rules for efficient Console use:

- Use the SHIFT key followed by the appropriate function key—ALARM, MONITOR, or CONFIG—to select the operating mode
- Use ▾ and ▴ to move around in the menu
- Use ▸ to enter a new menu, enter a new value, or select a menu item
- Use ◀ to exit the current menu or cancel an edit

SECTION 4—OPERATOR CONSOLE MODES

4.1 ALARM MODE

The Alarm mode is invoked when you press the SHIFT key followed by the ALARM key. This mode allows you to examine and reset any alarms that may exist. Use ∇ (\triangle) to examine the next (previous) active alarm.

4.1.1 RESETTING ONE ALARM

To reset an alarm, press \triangleright . You are prompted for confirmation; answering YES resets the alarm and advances you to the next alarm.

4.1.2 RESETTING ALL ALARMS

To reset all active alarms, press \triangleright . You are prompted for confirmation; press \triangleright to select ALL and press \triangleright to accept.

4.1.3 MONITOR MODE TRACKING

The Monitor mode “tracks” the Alarm mode. If the Monitor mode is selected while viewing an alarm, the controller will enter the MONITOR menu and display an appropriate reading.

For example, if you are examining a High Load Current Alarm and then select the Monitor mode, the starting point within the MONITOR menu will be the load current reading. Once the Monitor mode has been selected, you may move around in the menu using ∇ and \triangle .

4.1.4 ALARM MESSAGES

Table 4.1 lists sample alarms and the corresponding starting point in the Monitor mode menu, if it is invoked from the Alarm mode.

Table 4.1 Alarm Messages

Sample Alarm	Message	Monitor Mode Starting Point
LO TS 1	= -2°C	TS 1 temperature
HI TS 1	= 102°C	TS 1 temperature
TS 1 FAIL	= ALARM	TS 1 temperature
LO TS 2	= -4°C	TS 2 temperature
HI TS 2	= 105°C	TS 2 temperature
TS 2 FAIL	= ALARM	TS 2 temperature
CTL TS FAIL	= ALARM	Control temperature
LO LOAD	= 0.5 A	Load current
HI LOAD	= 21.0 A	Load current
HI GFI	= 52 mA	Ground fault current
GFI TRIP	= 77 mA	Ground fault current
LO VOLT	= 85 V	Voltage
HI VOLT	= 140 V	Voltage
LO RESIST	= 3.38 Ω	Resistance
HI RESIST	= 9.24 Ω	Resistance
OVERCURRENT TRIP	= ALARM	Load current
SWITCH FAIL	= ALARM	Load current
HTC RESET	= ALARM	Time since last reset
SWITCH LIMITING	= ALARM	Load current
C.B. LIMITING	= ALARM	Load current
POWER LIMITING	= ALARM	Power
EEROM DATA FAIL	= ALARM	n/a
CONTACTOR COUNT	= 200000	Contactor cycle count

4.2 MONITOR MODE

The Monitor mode is invoked when you press the SHIFT key followed by the MONITOR key.

This mode allows you to test the heat tracing and examine any of the analog readings. The data is updated in real-time, providing the user with a method of viewing tracer information as it occurs.

4.2.1 MAIN MENU

Table 4.2 Monitor Mode Main Menu

CONTROL MODE	=	4°C	
TS 1 TEMP	=	4°C	
TS 2 TEMP	=	7°C	(only if TS2 is being used)
LOAD	=	8.9 A	
RESIST	=	13.26 Ω	
GFI	=	0 mA	
VOLT	=	118 V	
POWER	=	1050 W	(or POWER = 10.4 kW)
TEST TRACING	=		(Turn on tracing for 30 seconds)
DISPLAY TEST	=		(To abort DISPLAY TEST, press any key)
MAINTENANCE DATA...	=		Note the "... " indicating a sub-menu
--- END ---			

4.2.2 "MAINTENANCE DATA..." SUB-MENU

This sub-menu is used to view minimum and maximum temperatures, total accumulated power, hours in use, and the number of hours since the last time the Controller was reset.

These parameters may be reset by the user.

CONTROL TEMP	=	4°C
TS 1 TEMP	=	4°C
TS 2 TEMP	=	7°C
LOAD	=	8.9 A
RESIST	=	13.26 Ω
GFI	=	0 mA
VOLT	=	118 V
POWER	=	1050 W
TEST TRACING		
DISPLAY TEST		
MAINTENANCE DATA...		
---- END ----		

Table 4.3 Maintenance Data Sub-Menu

MIN CTL TEMP	=	-2°C	
MAX CTL TEMP	=	65°C	
TS 1 MIN TEMP	=	-2°C	
TS 1 MAX TEMP	=	65°C	
TS 2 MIN TEMP	=	-1°C	
TS 2 MAX TEMP	=	61°C	
POWER ACCUM	=	145.9 kW-h	
CONTACTOR CYCLE COUNT	=	1234	(only if Deadband or Prop. Amb. Contactor modes are being used)
IN USE	=	2896 h	
TIME SINCE LAST RESET	=	675 h	
---- END ----			

4.3 CONFIGURE MODE

The Configure mode is selected when the operator presses the SHIFT key followed by the CONFIG key. This mode allows you to examine or alter the Controller's configuration. There are two types of configuration modes each presenting different features: Basic and Advanced.

The Basic Configuration Mode will limit the display to seven of the most commonly modified parameters, while the Advanced Configuration Mode presents all of the available parameters. Both Configure mode menus contain a parameter called FEATURE MODE which allows the user to specify which Configure mode is to be used.



IMPORTANT: All parameters that are enabled are active with their corresponding settings even if the Basic Configuration Mode is currently active. Selecting the Basic Configure mode of operation simply hides the display of certain parameters, but does not disable them.

Table 4.4 Basic Configure Mode Menu

CONTROL SETPOINT	=	{-60 to 570}°C
LO TS 1	=	{-60 to 570}°C
LO LOAD	=	{0.3 to 100.0} A
SWITCH CONTROL MODE	=	{Proportional, Prop. Amb., SSR, Deadband, or Prop. Amb. Contactor}
CIRCUIT BREAKER	=	{0.3 TO 100.0} A (only if SSR is being used)
TEMP UNITS	=	{°C or °F}
FEATURE MODE	=	{Basic or Advanced}
LOCK DATABASE	=	(Only if passcode is not 0 and database is unlocked)
UNLOCK DATABASE	=	(Only if passcode is not 0 and database is locked)
---- END ----		

4.3.2 ADVANCED CONFIGURE MODE MAIN MENU

Menu items with a trailing “...” indicate an entry point to a sub-menu. To enter a sub-menu, use ▾ and ▴ to position the menu item in the display and then press ▸. Note that the controller “remembers” where you are in the Configure mode if you temporarily switch to a different mode (such as the Monitor mode). Switching back to the Configure mode will return you to the same menu item.



IMPORTANT: A few of the controller parameters that are often used have been duplicated in the Advanced Configure mode main menu for quick access. These parameters (Lo TS 1, Lo Load, Hi GFI, GFI Trip) may also be accessed using their respective sub-menus.

Table 4.5 Advanced Configure Mode Main Menu

CONTROL SETPOINT	=	{-60 to 570}°C
LO TS 1	=	{-60 to 570}°C
LO LOAD	=	{0.3 to 100.0} A
HI GFI	=	{20 to 250} mA GFI TRIP= {20 to 250} mA
FEATURE MODE	=	{Basic or Advanced}
TS ALARMS CONFIG...		Note that the menu items with a trailing “...” indicate the
OTHER ALARMS CONFIG...		entry point to a sub-menu
POINT SETUP...		
MISC SETUP...		
COMMUNICATIONS SETUP...		
LOCK DATABASE		(Only if passcode is not 0 and database is unlocked)
UNLOCK DATABASE		(Only if passcode is not 0 and database is locked)
---- END ----		

This sub-menu is used to set up alarms that relate to any of the temperature sensors. Each alarm may be ENABled or DISAbled, and if the alarm is ENABled, an alarm setting may be entered.

4.3.3 “TS ALARMS CONFIG...” SUB-MENU

This sub-menu is used to set up alarms that relate to any of the temperature sensors. Each alarm may be ENABled or DISAbled, and if the alarm is ENABled, an alarm setting may be entered.

CONTROL SETPOINT = 20°C
LO TS 1 = -10°C
LO LOAD = 1.0 A
HI GFI = 50 mA
GFI TRIP = 75 mA
TS ALARMS CONFIG...
OTHER ALARMS CONFIG...
POINT SETUP...
MISC SETUP...
COMMUNICATIONS SETUP...
---- END ----

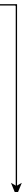

Table 4.6 TS Alarms Configuration Sub-Menu

TS 1 FAIL	=	{ENA or DIS}
LO TS 1	=	{ENA or DIS}
LO TS 1	=	{-60 TO 570}°C
HI TS 1	=	{ENA or DIS}
HI TS 1	=	{-60 TO 570}°C
TS 2 FAIL	=	{ENA or DIS}
LO TS 2	=	{ENA or DIS}
LO TS 2	=	{-60 TO 570}°C
HI TS 2	=	{ENA or DIS}
HI TS 2	=	{-60 TO 570}°C
LO TS FILTERS	=	{0 to 999} MIN (only if LO TS 1 or 2 are enabled)
HI TS FILTERS	=	{0 to 999} MIN (only if HI TS 1 or 2 are enabled)
LATCH TS ALARMS	=	{YES or NO}
CTL TS FAIL	=	{ENA or DIS}
---- END ----		

4.3.4 "OTHER ALARMS CONFIG..." SUB-MENU

This sub-menu allows the user to set up all alarms that do not directly relate to the temperature sensors. These include all AC alarms (voltage, current, ground fault, etc.) as well as protection settings such as power limiting, etc.

Each alarm may be ENabled or DISabled. If the alarm is ENabled, an alarm setting and filter setting may be entered.

CONTROL SETPOINT = 20°C
LO TS 1 = -10°C
LO LOAD = 1.0 A
HI GFI = 50 mA
GFI TRIP = 75 mA
TS ALARMS CONFIG...
OTHER ALARMS CONFIG...
POINT SETUP...
MISC SETUP...
COMMUNICATIONS SETUP...
---- END ----

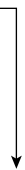

Table 4.7 Other Alarms Configuration Sub-Menu

LO LOAD	=	{ENA or DIS}	
LO LOAD	=	{0.3 to 100.0}	A
LO LOAD FILTER	=	{0 to 12}	S
HI LOAD	=	{ENA or DIS}	
HI LOAD	=	{0.3 to 100.0}	A
HI LOAD FILTER	=	{0 TO 12}	S
HI GFI	=	{ENA or DIS}	
HI GFI	=	{20 to 250}	mA
HI GFI FILTER	=	{0 to 12}	S
GFI TRIP	=	{ENA or DIS}	
GFI TRIP	=	{20 to 250}	mA
LO VOLT	=	{ENA or DIS}	
LO VOLT	=	{10 to 330}	V
LO VOLT FILTER	=	{0 to 12}	S
HI VOLT	=	{ENA or DIS}	
HI VOLT	=	{10 to 330}	V
HI VOLT FILTER	=	{0 to 12}	S
LO RESIST	=	{ENA or DIS}	
LO RESIST	=	{1 to 100}	%
LO RESIST FILTER	=	{0 to 12}	S
HI RESIST	=	{ENA or DIS}	
HI RESIST	=	{1 To 250}	%
HI RESIST FILTER	=	{0 to 12}	S
NOMINAL RESIST	=	{2.00 to 2000.00}	Ω (only if LO or HI is enabled)
OVERCURRENT TRIP	=	{ENA or DIS}	(only if SSR is being used)
SWITCH FAIL	=	{ENA or DIS}	
HTC RESET	=	{ENA or DIS}	
C.B. LIMITING	=	{ENA or DIS}	(only if SSR is being used)
POWER LIMITING	=	{ENA or DIS}	(only if SSR is being used)
SWITCH LIMITING	=	{ENA or DIS}	(only if SSR is being used)
CONTACTOR COUNT	=	{ENA or DIS}	(only if Deadband or Prop Amb Contactor are being used)
CONTACTOR COUNT	=	{0 to 999999}	(only if Deadband or Prop Amb Contactor are being used)
EEROM DATA FAIL	=	{ENA or DIS}	
---- END ----			

4.3.5 "POINT SETUP..." SUB-MENU

The "Point Setup" sub-menu is used to configure parameters that relate directly to the specific control point. Included in this menu are control mode settings, circuit breaker and switch ratings, autocycle set-up parameters, etc.

CONTROL SETPOINT = 20°C
LO TS 1 = -10°C
LO LOAD = 1.0 A
HI GFI = 50 mA
GFI TRIP = 75 mA
TS ALARMS CONFIG...
OTHER ALARMS CONFIG...
POINT SETUP...
MISC SETUP...
COMMUNICATIONS SETUP...
---- END ----



Table 4.8 Point Setup Sub-Menu

TAG	=	{19 ALPHANUMERIC CHARACTERS}	
SWITCH CONTROL MODE	=	{PROPORTIONAL, PROP AMB SSR, DEADBAND, or PROP AMB CONTACTOR}	
DEADBAND	=	{1 to 50}°C	(only if SWITCH CONTROL MODE is DEADBAND)
PROP BAND	=	{1 to 50}°C	(only if SWITCH CONTROL MODE is not DEADBAND)
CYCLE TIME	=	{10 to 255} MIN	(only if SWITCH CONTROL MODE is not PROP AMB CONTACTOR)
SWITCH RATING	=	{0.3 to 100.0} A	(only if SSR is being used)
CIRCUIT BREAKER	=	{0.3 to 100.00} A	(only if SSR is being used)
MAX POWER	=	{3 W to 33,000} W	(only if SSR is being used)
TS FAIL MODE	=	{OFF or ON}	
TS CTL MODE	=	{TS 1-FAIL OFF (ON) or TS 1-FAIL TO TS 2 or TS 2-FAIL OFF (ON) or TS 2-FAIL TO TS 1 or AVERAGE-FAIL OFF (ON) or AVERAGE-FAIL TO GOOD or LOWEST-FAIL OFF (ON) or LOWEST-FAIL TO GOOD}	
TS 1 TYPE	=	{100 W PLAT or NI-FE}	
TS 1 LEAD RESIST	=	{1 to 20.000} Ω	(only if TS 1 TYPE = NI-FE)
TS 1 HI LIMIT	=	{ENA or DIS}	
TS 2 TYPE	=	{100 W PLAT or NI-FE}	
TS 2 LEAD RESIST	=	{0 TO 20.000} Ω	(only if TS 2 TYPE = NI-FE)
TS 2 HI LIMIT	=	{ENA or DIS}	
AUTO-CYCLE	=	{ENA or DIS}	
AUTO-CYCLE INTERVAL	=	{1 to 240}	(only if AUTO-CYCLE=ENA)
AUTO-CYCLE UNITS	=	{HOURS or MINUTES}	(only if AUTO-CYCLE=ENA)
OVERRIDE SOURCE	=	{REMOTE or EXT INPUT}	
LOAD SHEDDING	=	{ENA or DIS}	
		---- END ----	

4.3.6 "MISC. SETUP..." SUB-MENU

The "Misc. Setup" sub-menu is used to configure miscellaneous parameters.

CONTROL SETPOINT = 20°C
LO TS 1 = -10°C
LO LOAD = 1.0 A
HI GFI = 50 mA
GFI TRIP = 75 mA
TS ALARMS CONFIG...
OTHER ALARMS CONFIG...
POINT SETUP...
MISC SETUP...
COMMUNICATIONS SETUP...
---- END ----



Table 4.9 Misc. Setup Sub-Menu

TEMP UNITS =	{°C or °F}
VERSION =	V3.16.3
EXT. INPUT =	{NOT USED, INHIBIT or FORCE ON}
FLASH ALARM OUTPUT =	{YES or NO}
ALARM OUTPUT =	{N.C. or N.O.}
LANGUAGE =	{ENGLISH or FRANCAIS}
PASSCODE =	{0000 to 9999} (only if 0 or database is unlocked)
SCROLL DELAY =	{0.07 to 0.25} S
LOAD DEFAULTS	
---- END ----	

4.3.7 “COMMUNICATIONS SETUP...” SUB-MENU

The settings found in this sub-menu must be configured whenever an optional communications board is installed in the Control Module.

CONTROL SETPOINT = 20°C
LO TS 1 = -10°C
LO LOAD = 1.0 A
HI GFI = 50 mA
GFI TRIP = 75 mA
TS ALARMS CONFIG...
OTHER ALARMS CONFIG...
POINT SETUP...
MISC SETUP...
COMMUNICATIONS SETUP...
---- END ----

Table 4.10 Communications Setup

PROTOCOL	= {HTCBUS or MODBUS ASCII or MODBUS RTU}	
HTCBUS ADDR	= {1 to 16777215}	(only if PROTOCOL=HTCBUS)
MODBUS ADDR	= {1 to 247}	(only if PROTOCOL≠HTCBUS)
MODBUS SUB ADDR	= {0 to 31}	(only if PROTOCOL≠HTCBUS)
BAUD RATE	= {AUTO or 9600 or 4800 or 2400 or 1200 or 600 or 300}	
PARITY	= {NONE or ODD or EVEN}	(only if PROTOCOL≠HTCBUS)
HARDWARE	= {NONE OR MODEM OR RS-232 or RS-485}	
DRIVER	= {AUTO or RS-485 or RS-232 or MODEM}	
PROFILE	= {AUTO or 3-WIRE RS-232 or RS-485 or 1200 BAUD MODEM or 300 BAUD MODEM}	
Tx DELAY	= {0.00 to 2.50} S	
----	END	----

SECTION 5—CONFIGURATION PARAMETER DETAILS

5.1 INTRODUCTION

The sections that follow explain the various functions of the 910 controller and how they may be accessed. The first line of each section identifies the function to be described. Each section goes on to explain the purpose of the function, the range over which it may be set, the procedure for setting or enabling the feature, and finally any Notes or Cautions that pertain to the particular function.

Setting and using the alarming functions of the 910 controller is a two step **Procedure**:

1. The alarm must be enabled or disabled as desired. When using the Operator Console, access to all alarming functions is available using the ADVANCED CONFIGURE mode submenus. When using either the Model 780/GCC-9000 Group Communications Controller, the alarm masks may be found in the HTC SET-UP Section. Please see the appropriate operating manual for instructions on accessing controller parameters using these devices.
2. The corresponding alarm point value may be modified appropriately for the application. When using the Operator Console, access to the alarm points is also available using the ADVANCED CONFIGURE mode sub-menus. Modification of the alarm setpoint values is found in the HTC SETPOINTS Section of the Model 780/GCC-9000 Group Communications Controller. Please see the appropriate operating manual for instructions on accessing controller parameters using these devices.



IMPORTANT: The Operator Console and the Model 780/GCC-9000 will NOT allow modification of an alarm point value if the alarm has been disabled (DIS) with the exception of the HIGH TS ALARM temperature settings. These may still be modified if the corresponding HIGH LIMIT CUTOFF has been enabled (ENA) to incorrect design or factors outside those considered by the design.

5.2 POINT SETUP PARAMETERS

This section describes the setup parameters that relate to the 910.

5.2.1 CONTROL SETPOINT TEMPERATURE

Purpose: The CONTROL SETPOINT temperature is the value at which the heat trace controller maintains the circuit temperature through either proportional, proportional ambient SSR, proportional ambient contactor, or deadband control, depending on the controllers' configuration. The CONTROL SETPOINT temperature is compared to the temperature measured by the control temperature sensor (TS). A decision is then made to turn on or turn off the output to control power to the tracer.

Range: -76°F to 1058°F (-60°C to 570°C)

Procedure: Adjust the CONTROL SETPOINT temperature value to the desired maintain temperature. The HTC will switch the output ON and OFF in an attempt to maintain this temperature.



IMPORTANT:

- See Section 7.2 of this manual for an explanation of Proportional, Proportional Ambient SSR, Proportional Ambient Contactor, and Deadband Control algorithms.
- When using the Operator Console, the CONTROL SETPOINT temperature range may be limited by the CONSOLE SETPOINT MAXIMUM and MINIMUM values (see Sections 5.2.23 and 5.2.24). This is a safety feature to prevent users in the field from modifying the CONTROL SETPOINT temperature setting to a dangerous level.

5.2.2 ALPHANUMERIC TAG ASSIGNMENT

Purpose: A 19 character alphanumeric TAG may be assigned to a control point to allow it to be easily associated with a pipe, vessel, process, circuit, drawing name, or number.

Setting: Any combination of 19 characters from A-Z, 0-9, /, -, ., (,), or #.

Procedure: Using the Operator Console, enter the desired text.

5.2.3 SWITCH CONTROL MODE

Purpose: This allows selection of the type of algorithm to be used by the HTC to maintain the CONTROL SETPOINT temperature. There are four different control algorithms available in the HTC—proportional, proportional ambient SSR, proportional ambient contactor, and deadband. See Section 7.2 for a complete explanation of these controlling techniques as implemented in the HTC.

Setting: PROPORTIONAL, PROPORTIONAL AMBIENT SSR, PROPORTIONAL AMBIENT CONTACTOR, or DEADBAND

Procedure: Select the desired control technique. Note that deadband control and proportional ambient contactor should be selected when using contactors or when precise control and advanced current handling functions are not required.



IMPORTANT: If deadband is selected, a DEADBAND setting will be available in the HTC configuration menu; otherwise, a PROPORTIONAL BAND setting will be available. No MAXIMUM POWER, SWITCH CURRENT RATING, or CIRCUIT BREAKER CURRENT RATING settings are available when the controller is set to operate in either contactor mode. If proportional ambient contactor is selected, the CYCLE TIME setting will also be available.

5.2.4 PROPORTIONAL BAND SETTING

(For use with the three proportional control modes only).

Purpose: When an HTC equipped with SSRs is used to control a heating circuit, proportional or proportional ambient SSR modes are normally used, allowing for more precise temperature control. When using contactors, the proportional ambient contactor mode should be selected.

This programmable proportional band acts to vary the on to off time of the output based on the difference between the measured control temperature and the desired CONTROL SETPOINT temperature.

Range: 2°F to 90°F (1°C to 50°C)

Procedure: Adjust the PROPORTIONAL BAND setting to the desired differential from the CONTROL SETPOINT temperature.



IMPORTANT:

- See Section 7.2 of this manual for an explanation of how the three proportional modes use the PROPORTIONAL BAND setting.
- When using Series-type, constant wattage, or self-regulating tracers in an ambient temperature control application, significant energy savings may be realized by setting the PROPORTIONAL BAND to match the expected range of operating ambient temperatures. Tracer design is normally done assuming worst-case conditions, where 100% of the design output power is required to maintain the desired minimum temperature. When the ambient temperature is above the design minimum, but some heat is still required, adjusting the PROPORTIONAL BAND width accordingly will allow only the amount of power required by the application to be consumed, while maintaining the minimum required temperature.

Example: A water line must be protected from freezing when the ambient temperature falls below 10°C. Either the proportional ambient SSR or proportional ambient contactor mode is selected as the control method (depending on the type of switch being used). The heater and insulation combination are chosen to impart enough heat to the line to keep it from freezing at a worst-case ambient temperature of -40°C. At 10°C, the heater should be completely off, since no heat is required at this temperature to guarantee that the product will not freeze. It follows that the amount of heat required by the water line decreases as the ambient temperature increases from -40°C to 10°C (theoretically, at -15°C the heater output should be approximately 50%). Setting the CONTROL SETPOINT temperature to 10°C, and the PROPORTIONAL BAND to 50°C, will force the controller's output to be 100% on at -40°C, 50% on at -15°C, and off at 10°C.

5.2.5 DEADBAND SETTING

(Deadband control mode only)

Purpose: When an HTC equipped with a contactor is used to control a heating circuit, it is necessary to use deadband rather than proportional control. This is done to prevent the contactor from switching on and off rapidly and being worn out prematurely. This deadband acts as an on/off control where the decision to turn the output off or on is based upon a window of difference between the measured control temperature and the desired CONTROL SETPOINT temperature.

Range: 2°F to 90°F (1°C to 50°C)

Procedure: Adjust the DEADBAND setting to the desired differential from the desired CONTROL SETPOINT temperature. When the control temperature is above the setpoint + dead- band value, the controller will turn off the output to the tracer. If the control temperature drops down below the setpoint, the output will be turned back on. Note that the smaller the DEADBAND setting, the more often the contactor will cycle on and off, decreasing its opera- tional life.



IMPORTANT: See Section 7.2 of this manual for an explanation of Deadband Control. Note that the MAXIMUM POWER, SWITCH CURRENT RATING, and CIRCUIT BREAKER CURRENT RATING settings are not available when the HTC is set to Deadband mode (typically when switching a contactor).

5.2.6 CYCLE TIME SETTING

(For proportional ambient contactor control mode only).

Purpose: This parameter determines the minimum amount of time it will take for a complete contactor ON-OFF-ON cycle.

Range: 10 to 255 minutes

Procedure: Adjust the CYCLE TIME setting to yield the desired contactor ON+OFF time for a particular duty cycle. For instance, if the contactor should remain on for five minutes with a 50% duty cycle, then the CYCLE TIME should be 10 minutes. A new duty cycle (based on measured control temperature, PROPORTIONAL BAND, and CONTROL SETPOINT) is calculated every time the contactor is required to change state.



IMPORTANT:

- If the calculated duty cycle is 0% or 100%, then the contactor will not change state and the duty cycle will not be calculated again for a time period = CYCLE TIME/30.
- The minimum cycle time setting is 10 minutes, and the minimum controller output duty cycle is 3%. This results in a minimum contactor ON time of 18 seconds.

5.2.7 SWITCH CURRENT RATING SETTING (SSR ONLY)

Purpose: The SWITCH CURRENT RATING setting defines the current rating of the output switch. It is used by the controller to limit the maximum average current that will be allowed to flow to the load before it begins to adjust the output duty cycle, limiting the amount of current to an acceptable level.

Range: 0.3 to 100.0 Amps

Procedure: Adjust the SWITCH CURRENT RATING setting to the match the current rating of the output device (i.e. 30.0 Amps).

5.2.8 CIRCUIT BREAKER CURRENT RATING SETTING (SSR ONLY)

Purpose: The CIRCUIT BREAKER CURRENT RATING setting helps prevent in-rush induced nuisance tripping of the circuit breaker immediately upstream of the controller. The HTC evaluates the square of the current related to time (I^2t) and adjusts the output duty cycle accordingly, limiting the amount of current to an acceptable level.

Range: 0.3 to 100.0 Amps

Procedure: Adjust the CIRCUIT BREAKER CURRENT RATING setting to the heating circuit breaker size (i.e. 30.0 Amps).



IMPORTANT: This feature should NOT be used to reduce the size of a circuit breaker or increase the maximum heating cable length. It can be quite effective in preventing nuisance trips due to incorrect design or factors outside those considered by the design.

5.2.9 MAXIMUM POWER SETTING (SSR ONLY)

Purpose: This user selectable level limits the maximum amount of power applied to a heat trace circuit. This is an average power calculated by the controller using the average current and applied voltage. The HTC switches the output on and off rapidly to limit the average current to an appropriate level. The MAXIMUM POWER level may be adjusted to eliminate stepdown transformers, lower the effective output wattage of a cable, or implement energy management of the heat trace circuit.

Range: 3 to 33,000 Watts

Procedure: Adjust the MAXIMUM POWER level to the desired value (watts). Use the TEST TRACING function to observe the power limiting operation.



IMPORTANT:

- This function may be set within reasonable limits for the particular tracer being powered. The effective resolution of the setting is limited to 1/30th of the calculated full on power.
- Do not set the MAXIMUM POWER below full output for applications that do not require power limiting.

5.2.10 TS FAIL MODE

Purpose: This parameter determines whether the HTC turns the output switch ON or OFF if all selected temperature sensors fail to provide a valid control temperature.

Setting: OFF or ON

Procedure: If the HTC should turn the output switch off when it cannot read a valid control temperature, then select OFF, otherwise if the output switch should turn on, then select ON.



IMPORTANT: This parameter is part of the TS CONTROL MODE.

5.2.11 TEMPERATURE SENSOR CONTROL MODE

Purpose: The TS CONTROL MODE allows the selection of one of eight possible temperature control modes for the controller. The different modes allow redundant fail-safe temperature sensing, averaging, or minimum maintain temperature control.

Setting: Select one of the following eight possible modes:

CONTROL TS AND DESCRIPTION
CONTROL USING TS 1, FAIL OFF/ON
CONTROL USING TS 1, FAIL TO TS 2
CONTROL USING TS 2, FAIL OFF/ON
CONTROL USING TS 2, FAIL TO TS 1
CONTROL ON AVERAGE, FAIL OFF/ON
CONTROL ON AVERAGE, FAIL TO GOOD
CONTROL ON LOWEST, FAIL OFF/ON
CONTROL ON LOWEST, FAIL TO GOOD

Where OFF/ON = Controllers' output switch turned OFF or ON as determined by the TS FAIL MODE.

Example: With a TS CONTROL MODE of CONTROL ON AVERAGE, FAIL TO GOOD, the controller will measure both sensors (TS 1 and TS 2), averaging the two temperature values, display the results, and cycle the heater ON or OFF to maintain the CONTROL SETPOINT temperature. This is the primary control mode. If either sensor should fail, the controller will transfer control to the remaining "good" sensor and generate the appropriate TS 1 or TS 2

FAILURE ALARM (assuming that the alarm is enabled). The temperature will now be maintained based on this measured value. If the remaining "good" sensor fails, the controller will turn the heater OFF or ON as determined by the TS FAIL MODE setting. The appropriate TS

1 or TS 2 FAILURE ALARM will be also be generated.

Procedure: Select the control mode that best suits the application.



IMPORTANT: Ensure that TS FAILURE ALARMS are enabled. See Sections 5.4.1, 5.4.4, and 5.4.10 for a complete explanation of RTD failure detection in the HTC.

5.2.12 TS 1 TYPE

Purpose: This parameter specifies the type of RTD that is connected to the HTC's TS 1 input.

Setting: 3 wire 100 Ω Platinum or 2 (or 3) wire 100 Ω Nickel Iron (NI-FE).

Procedure: Select the type of RTD that is connected to the TS 1 input.



IMPORTANT: If a 2 wire 100 Ω Nickel Iron (NI-FE) RTD is selected then the TS 1 LEAD RESISTANCE must be entered manually (see Section 5.2.13).

5.2.13 TS 1 LEAD RESISTANCE

(For NI-FE RTDs only.)

Purpose: This parameter specifies the lead resistance of a 2 wire Nickel Iron RTD connected to the HTC's TS 1 input.

Range: 0 to 20.00 Ω

Procedure: Measure the resistance of one of the Nickel Iron RTD leads (from the RTD to the HTC's TS 1 input) and use this value as the TS 1 LEAD RESISTANCE.

5.2.14 TS 1 HIGH LIMIT CUTOUT

Purpose: When enabled, the TS 1 high limit cutout feature will override the CONTROL SETPOINT temperature and force the controller output off if the TS 1 reading exceeds the HIGH TS 1 ALARM temperature setting. This is a non-latching condition, so once the TS 1 reading drops below the HIGH TS 1 ALARM temperature setting, the controller will resume normal operation.

Setting: ENABLE or DISABLE



Procedure: Enable or disable the cutout feature as desired.

IMPORTANT:

- The TS 1 HIGH LIMIT CUTOUT feature overrides an autocycle test. A pending autocycle will be initiated immediately after the TS 1 temperature drops below the HIGH TS 1 ALARM temperature setting.
- If a TS 1 failure occurs and the TS 1 HIGH LIMIT CUTOUT feature is enabled, the switch output will latch off regardless of the TS CONTROL MODE setting or the TS FAIL MODE setting.
- If the TS 1 HIGH LIMIT CUTOUT feature is enabled, then the HIGH TS 1 ALARM temperature setting can be set, regardless of whether the HIGH TS 1 ALARM is enabled.

5.2.15 TS 2 TYPE

Purpose: This parameter specifies the type of RTD that is connected to the HTC's TS 2 input.

Setting: 3 wire 100 Ω Platinum or 2 (or 3) wire 100 Ω Nickel Iron (NI-FE).



Procedure: Select the type of RTD that is connected to the TS 2 input.

IMPORTANT: If a 2 wire 100 Ω Nickel Iron (NI-FE) RTD is selected then the TS 2 LEAD RESISTANCE must be entered (see Section 5.2.16).

5.2.16 TS 2 LEAD RESISTANCE

(For NI-FE RTDs only.)

Purpose: This parameter specifies the lead resistance of a 2 wire Nickel Iron RTD connected to the HTC's TS 2 input.

Range: 0 to 20.00 Ω

Procedure: Measure the resistance of one of the Nickel Iron RTD leads (from the RTD to the HTC's TS 2 input) and use this value as the TS 2 LEAD RESISTANCE.

5.2.17 TS 2 HIGH LIMIT CUTOUT

Purpose: When enabled, the TS 2 high limit cutout feature will override the CONTROL SETPOINT temperature and force the controller output off if the TS 2 reading exceeds the HIGH TS 2 ALARM temperature setting. This is a non-latching condition, so once the TS 2 reading drops below the HIGH TS 2 ALARM temperature setting, the controller will resume normal operation.

Setting: ENABLE or DISABLE



Procedure: Enable or disable the cutout feature as desired.

IMPORTANT:

- The TS 2 HIGH LIMIT CUTOUT feature overrides an autocycle test. A pending autocycle will be initiated immediately after the TS 2 temperature drops below the HIGH TS 2 ALARM temperature setting.
- If a TS 2 failure occurs and the TS 2 HIGH LIMIT CUTOUT feature is enabled, the switch output will latch off regardless of the TS CONTROL MODE setting or the TS FAIL MODE setting.
- If the TS 2 HIGH LIMIT CUTOUT feature is enabled, then the HIGH TS 2 ALARM temperature setting can be set, regardless of whether the HIGH TS 2 ALARM is enabled.

5.2.18 AUTOCYCLE ENABLING

Purpose: The autocycle function momentarily (approximately 10 seconds) applies power to the heating circuit at the selected interval. It is used to test the integrity of the heating circuit. Alarms present at the time of autocycle then become latched and remain active after the completion of the autocycle function. Autocycling effectively eliminates the need for preventive maintenance by automatically verifying the heating circuit integrity.

Setting: ENABLE or DISABLE

Procedure: Enable or disable the autocycling feature as desired. If the feature is disabled, you will not be prompted to enter the AUTOCYCLE INTERVAL or AUTOCYCLE UNITS.



IMPORTANT:

- Autocycling should always be enabled for normal operation. Disabling this feature should only be required where the HTC system is monitoring a circuit exercised by some other device or means. Although this function defeats temperature control and forces output on, the controller will continue to adjust the output for protection purposes or power limiting (SSR option only).
- Autocycling is inhibited if the controller is in the load shedding mode. See Section 7.3.
- If autocycling is enabled, the HTC will always autocycle for 10 seconds when power is initially applied.
- If autocycling is enabled, and TS FAIL MODE = OFF and all the control temperature sensors have failed, the HTC will still perform an autocycle.
- If an alarm condition with an alarm filter time greater than 0 appears during the autocycling, then the autocycle will be extended (past the 10 seconds) until the alarm filter time has expired.

5.2.19 AUTOCYCLE TIME INTERVAL

Purpose: AUTOCYCLE INTERVAL is the number of hours/minutes between successive heating circuit integrity tests depending on the AUTOCYCLE UNITS specified.

Range: 1 to 240

Procedure: Set the AUTOCYCLE INTERVAL to the desired time period.



IMPORTANT:

- When using proportional ambient contactor mode, the CYCLE TIME setting should be less than the AUTOCYCLE INTERVAL; otherwise, autocycling could affect the duty-cycle.
- If an AC ALARM becomes active during an autocycle, but the AUTOCYCLE INTERVAL expires prior to the corresponding ALARM FILTER time, then autocycling will continue until the ALARM FILTER time has elapsed.
- For the earliest possible alarming of heating circuit problems, the AUTOCYCLE INTERVAL should be set to a small value.

5.2.20 AUTOCYCLE TIME UNITS

Purpose: The autocycle time units parameter allows selection of minutes or hours for the AUTOCYCLE INTERVAL setting.

Setting: HOURS or MINUTES

Procedure: Set the AUTOCYCLE UNITS to the desired time units.

5.2.21 OVERRIDE SOURCE

Purpose: An override signal can be sent to the HTC from one of two sources. This override signal can be used to override the controller's temperature control and force the output switch off or on. This is especially useful when the user wishes to turn a controller or a group of controllers off over the summer months, during maintenance, or when a line is flowing and does not require heating.

Setting: REMOTE or EXT. INPUT

Procedure: If the override signal will be generated remotely and received by the HTC via the optional communications interface, select REMOTE as the OVERRIDE SOURCE. If the override signal will be received by the HTC via the external input, select EXTERNAL INPUT as the OVERRIDE SOURCE.

**IMPORTANT:**

- If the EXTERNAL INPUT is not configured as either INHIBIT or FORCE ON then OVERRIDE SOURCE will always automatically be set to REMOTE. See Section 5-3-3 for further details.
- If the autocycle feature is enabled, it will continue to function even when an INHIBIT override signal is being received as long as load shedding is not active.
- Fail safe mode is inactive if an INHIBIT override signal is being received.
- Load shedding and fail safe modes are inactive if a FORCE ON override signal is being received.
- Only the LOW TS ALARMS for temperature sensors used by the TS CONTROL MODE are inactive if an INHIBIT override signal is being received.

5.2.22 LOAD SHEDDING ENABLING

Purpose: The load shedding function allows the controller output to be forced OFF by way of a remote contact input on the 780 Group Communications Controller or using the communications port and an upstream device. It may be used to turn OFF the output of one or more controllers in order to reduce energy consumption to avoid peak demand surcharges, remove power from unused circuits, or remove power from circuits which may be subjected to steam cleaning.

Setting: ENABLE or DISABLE



Procedure: Enable or disable the load shedding control mode as desired.

IMPORTANT: To completely configure the HTC for load shedding operation, the following additional parameters must be set up using the Model 780/GCC-9000:

Fail Safe Mode

Load Shedding GCC Contact Association

These additional parameters may only be accessed using the Group Communications Controller. See the appropriate Section of the GCC manual for further details.

**IMPORTANT:**

- Fail safe mode is not supported when using proportional ambient SSR or proportional ambient contactor modes.
- For fail safe mode to function, at least one LOW TS ALARM of the controlling temperature sensor(s) must be enabled and the corresponding LOW TS ALARM temperature setting must be less than the CONTROL SETPOINT temperature.

5.2.23 CONSOLE SETPOINT MAXIMUM

Purpose: When using the Operator Console the maximum setting of the CONTROL SETPOINT temperature may be limited to the CONSOLE SETPOINT MAXIMUM value. This is a safety feature to prevent users in the field from modifying the CONTROL SETPOINT temperature setting to a dangerous level.

Range: -76°F to 1058°F (-60°C to 570°C)

Procedure: Adjust the CONSOLE SETPOINT MAXIMUM temperature value to limit the maximum allowable CONTROL SETPOINT TEMPERATURE that may be set using the Operator Console. The CONSOLE SETPOINT MAXIMUM may only be set using a communicating device such as the Model 780/GCC-9000. See the 780/GCC-9000 user manual for the proper procedure.



IMPORTANT: The CONSOLE SETPOINT MAXIMUM is not displayed on the Operator Console.

5.2.24 CONSOLE SETPOINT MINIMUM

Purpose: When using the Operator Console the minimum setting of the CONTROL SETPOINT temperature may be limited to the CONSOLE SETPOINT MINIMUM value. This is a safety feature to prevent users in the field from modifying the CONTROL SETPOINT temperature setting to a dangerous level.

Range: -76°F to 1058°F (-60°C to 570°C)

Procedure: Adjust the CONSOLE SETPOINT MINIMUM temperature value to limit the minimum allowable CONTROL SETPOINT TEMPERATURE that may be set using the Operator Console. The CONSOLE SETPOINT MINIMUM may only be set using a communicating device such as the Model 780/GCC-9000. See the 780/GCC-9000 manual for the proper procedure.



IMPORTANT: The CONSOLE SETPOINT MINIMUM is not displayed on the Operator Console.

5.3 MISCELLANEOUS SETUP PARAMETERS

The following section describes miscellaneous the setup parameters.

5.3.1 TEMPERATURE DISPLAY UNITS

Purpose: This allows selection of the type of temperature units to display on the Operator Console. All temperature related values will be displayed in the selected units.

IMPORTANT: This setting will not affect the temperature units displayed at a 780/GCC-9000 Group Communications Controller. The GCC may be set independently.

Setting: DEGREES F or DEGREES C



Procedure: Adjust the setting to the desired temperature units (°F or °C).

IMPORTANT: To minimize possible confusion, it is recommended that the temperature units be set the same on the HTC and any other communicating devices.

5.3.2 VERSION OF FIRMWARE AND HARDWARE

Purpose: The first three digits indicate the revision level of the firmware programmed into the controller. As new features are added to the HTC, the firmware revision level is incremented to allow the user to determine which features are available for the particular unit being used.

5.3.3 EXTERNAL INPUT PORT

Purpose: This input port may be used as an OVERRIDE SOURCE to sense a remote dry contact closure. This will override the controller's temperature control and force its output switch off or on.

Setting: NOT USED, INHIBIT, or FORCE ON

Procedure: If the EXTERNAL INPUT is not being used, select NOT USED. If a remote dry contact closure should force the output switch off then select INHIBIT. If a remote dry contact closure should force the output switch on, then select FORCE ON.

If the EXTERNAL INPUT is set to INHIBIT or FORCE ON, then OVERRIDE SOURCE must be set to EXT. INPUT.



IMPORTANT:

- When used with the INHIBIT/FORCE ON feature, a contact closure sensed by the EXTERNAL INPUT will initiate the INHIBIT/FORCE ON mode. An open input will cause the controller to revert to normal temperature control operation.

One possible use of the INHIBIT feature is to use an external device (such as a flow meter) to provide a contact closure if there is flow in a line. As long as the line has adequate flow, the heating will be off (INHIBITed from operating). See Appendix C for typical connection diagrams when using this input.

- EXTERNAL INPUT must be set to INHIBIT or FORCE ON before OVERRIDE SOURCE can be set to EXT. INPUT. Setting EXTERNAL INPUT to NOT USED or TEMPBUS™ will automatically set OVERRIDE SOURCE to REMOTE.

5.3.4 FLASH ALARM OUTPUT SETTING

Purpose: Programs both the alarm output relays (dry contact and AC alarm) for flashing or steady output in case of an alarm condition.

Setting: YES (Flash) or NO (Steady)

Procedure: Set the alarm output relays to flash or not to flash on an alarm condition, whichever suits the application.



IMPORTANT:

- If the alarm output is used to drive a pilot light, it is recommended that YES be selected to enable flashing operation. When the output is also configured for normally closed operation, the pilot light will be on steady for normal operation, flash in case of alarm, and be extinguished due to a bulb failure or loss of power.

-
- If multiple alarm outputs from different controllers are wired in series (i.e.: multi-point panels), set this parameter to NO (steady).

5.3.5 ALARM OUTPUT NORMAL STATE

Purpose: Configures both the alarm output relays (dry contact and AC alarm) for normally open or normally closed operation. The normal condition is assumed to be when the HTC is powered and no alarms exist.

Setting: N.O. (Normally Open) or N.C. (Normally Closed)

Procedure: Set the alarm output relays to normally open or normally closed to suit the application.



IMPORTANT: If a pilot light is used for indication of alarms, normally closed operation provides a steady illumination of the lamp when the circuit is operating correctly. A light that is flashing or out indicates a fault condition. A burned out lamp is readily identified if the HTC is set to flash the dry contact alarm output relay and the AC Alarm Relay output in case of alarm.

See the Section 5.3.4.

5.3.6 LANGUAGE

Purpose: Defines which language the Operator Console is to use when prompting the user for input and/or displaying messages and status.

Setting: ENGLISH or FRANCAIS

Procedure: Select the language of choice: ENGLISH for English prompts and messages, or FRANCAIS for French prompts and messages.

5.3.7 PASSCODE

See Section 5.7.1.

5.3.8 SCROLL DELAY SETTING

Purpose: Allows the user to modify the speed at which information is scrolled on the Operator Console for ease of viewing.

Range: 0.07 to 0.25 seconds

Procedure: Decreasing the scroll delay value will cause the information on the display to scroll by faster. Increasing the scroll delay value will cause the information on the display to scroll by slower.

5.4 TEMPERATURE SENSOR ALARMS CONFIGURATION

This section defines the temperature related alarming functions of the 910 controller.

5.4.1 TEMPERATURE SENSOR 1 FAILURE ALARM

Purpose: Enabling TS 1 FAILURE will provide indication of an open or shorted failure of TS 1.

Alarm Mask: ENABLE or DISABLE

Procedure: Enable or disable alarming of a failed temperature sensor connected to the TS 1 input as required.



IMPORTANT:

- This failure alarm should be enabled if a temperature sensor is connected to the TS 1 input.
- This alarm is always latched and must be reset by the user.

5.4.2 LOW TEMPERATURE SENSOR 1 ALARM

Purpose: If enabled, the LOW TS 1 ALARM allows for alarming of low temperature conditions as sensed by the first temperature sensor (TS 1).

Alarm Mask: ENABLE or DISABLE

Range: -76°F to 1058°F (-60°C to 570°C)

Procedure: Adjust the LOW TS 1 ALARM temperature setpoint to the desired value. Note that the LOW TS 1 ALARM must be enabled in order to adjust the LOW TS 1 ALARM temperature setpoint.

**IMPORTANT:**

- This alarm should normally be enabled and the setpoint should be appropriate for the heating application. Maintaining a minimum 5°C differential between low temperature alarming and the CONTROL SETPOINT temperature will minimize nuisance alarming due to momentary dips in temperature. Another alternative to this is to configure the controller for non-latching temperature alarms.
- This alarm must be enabled and its setpoint must be below the CONTROL SETPOINT temperature if fail safe mode uses the temperature reading from TS 1.

5.4.3 HIGH TEMPERATURE SENSOR 1 ALARM

Purpose: If enabled, the HIGH TS 1 ALARM allows for alarming of high temperature conditions as sensed by the first temperature sensor (TS 1).

Alarm Mask: ENABLE or DISABLE

Range: -76°F to 1058°F [-60°C to 570°C]

Procedure: Adjust the HIGH TS 1 ALARM temperature setpoint to the desired value. Note that the HIGH TS 1 ALARM must be enabled in order to adjust the HIGH TS 1 ALARM temperature setpoint unless the TS 1 high limit cutout feature is enabled.



IMPORTANT: This alarm should only be used for applications where a product that is sensitive to over temperature is involved. General usage may result in nuisance alarms due to the flow of hot product or steam out. This may be a case where the alarm should be enabled and non-latching temperature alarming should be used. A high temperature condition resulting from a forced on failure of the heating circuit should first be alarmed by the SWITCH FAILURE ALARM. See Section 5.5.18 for more information.

5.4.4 TEMPERATURE SENSOR 2 FAILURE ALARM

Purpose: Enabling TS 2 FAILURE will provide indication of an open or shorted failure of TS 2.

Alarm Mask: ENABLE or DISABLE

Procedure: Enable or disable alarming of a failed temperature sensor connected to the TS 2 input as required.

**IMPORTANT:**

- If no second sensor is installed, this alarm should be disabled. This failure alarm should be enabled if a second temperature sensor is connected to the TS 2 input.
- This alarm is always latched and must be reset by the user.

5.4.5 LOW TEMPERATURE SENSOR 2 ALARM

Purpose: If enabled, the LOW TS 2 ALARM allows for alarming of low temperature conditions as sensed by the second temperature sensor (TS 2).

Alarm Mask: ENABLE or DISABLE

Range: -76°F to 1058°F [-60°C to 570°C]

Procedure: Adjust LOW TS 2 ALARM temperature setpoint to the desired value. Note that the LOW TS 2 ALARM must be enabled in order to adjust the LOW TS 2 ALARM temperature setpoint.

**IMPORTANT:**

- If no second sensor is installed this alarm should be disabled. This alarm should be enabled and the setpoint should be appropriate for the heating application. Maintaining a minimum 5°C differential between low temperature alarming and the CONTROL SETPOINT temperature will minimize nuisance alarming due to momentary dips in temperature. Another alternative to this is to configure the controller for non-latching temperature alarms.
- This alarm must be enabled and its setpoint must be below the CONTROL SETPOINT temperature if fail safe mode uses the temperature from TS 2.

5.4.6 HIGH TEMPERATURE SENSOR 2 ALARM

Purpose: If enabled, the HIGH TS 2 ALARM allows for alarming of high temperature conditions as sensed by the second temperature sensor (TS 2).

Alarm Mask: ENABLE or DISABLE

Range: -76°F to 1058°F (-60°C to 570°C)

Procedure: Adjust the HIGH TS 2 ALARM temperature setpoint to the desired value. Note that the HIGH TS 2 ALARM must be enabled in order to adjust the HIGH TS 2 ALARM temperature setpoint unless the TS 2 high limit cutout feature is enabled.



IMPORTANT: If no second sensor is installed this alarm should be disabled. This alarm may be used for applications where a product that is sensitive to over temperature is involved. General usage could result in nuisance alarms due to the flow of hot product or steam out. This may be a case where the alarm could be enabled and non-latching temperature alarming used. A high temperature condition resulting from a forced on failure of the heating circuit should first be alarmed by the SWITCH FAILURE ALARM. See Section 5.5.18 for more information.

5.4.7 LOW TEMPERATURE SENSOR ALARM FILTER TIME SETTING

Purpose: The LOW TS ALARM FILTER will prevent LOW TS 1 and/or LOW TS 2 ALARMS from being indicated until their corresponding alarm condition has existed for the duration of the LOW TS ALARM FILTER time.

Range: 0 to 999 minutes

Procedure: Adjust the LOW TS ALARM FILTER time to the desired value. Note that either the LOW TS 1 ALARM and/or the LOW TS 2 ALARM must be enabled in order to adjust the LOW TS ALARM FILTER time.



IMPORTANT:

- If an alarm condition appears and then disappears before the alarm filter time has expired, the filter timer is reset and the alarm condition must exist again for the entire alarm filter time before the corresponding alarm will be indicated.
- If the user resets an alarm while the alarm condition is still exists, then the alarm will not be indicated again until the entire alarm filter time has expired.

5.4.8 HIGH TEMPERATURE SENSOR ALARM FILTER TIME SETTING

Purpose: The HIGH TS ALARM FILTER will prevent HIGH TS 1 and/or HIGH TS 2 ALARMS from being indicated until their corresponding alarm condition has existed for the duration of the HIGH TS ALARM FILTER time.

Range: 0 to 999 minutes

Procedure: Adjust the HIGH TS ALARM FILTER time to the desired value. Note that either the HIGH TS 1 ALARM and/or the HIGH TS 2 ALARM must be enabled in order to adjust the HIGH TS ALARM FILTER time.



IMPORTANT:

- If an alarm condition appears and then disappears before the alarm filter time has expired, the filter timer is reset and the alarm condition must exist again for the entire alarm filter time before the corresponding alarm will be indicated.
- If the user resets an alarm while the alarm condition is still exists, then the alarm will not be indicated again until the entire alarm filter time has expired.
- The HIGH TS ALARM FILTER time setting will not affect the cutout time when the HIGH LIMIT CUTOFF feature is enabled.

5.4.9 LATCH TEMPERATURE SENSOR ALARMS SETTING

Purpose: This allows for the selection of automatic clearing of all HIGH and LOW TS ALARMS (non-latching) when a temperature alarm condition no longer exists or permanent alarming of such a condition (latching) until the alarm is manually reset.

Setting: YES (LATCHING) or NO (NON-LATCHING)

Procedure: Adjust the LATCH TS ALARMS setting to the desired mode (latching or nonlatching).



IMPORTANT:

- If your application is subject to periodic situations where cold or hot product is part of the process, it may be appropriate to configure the HTC for non-latching temperature alarms to avoid nuisance alarms. If it is important to be aware of any temperature alarm conditions that may have existed in a pipe, then the HTC should be configured for latching temperature alarms.
- This setting does not affect the TS FAILURE ALARMS—these are always latching.

5.4.10 CONTROL TEMPERATURE SENSOR FAILURE ALARM

Purpose: Control TS FAILURE ALARM indicates a failure of the temperature sensor designated as the control sensor.

One of eight TS CONTROL MODES may be selected. These modes determine which TS input(s) is(are) designated to provide the control temperature. See Section 5-2-11 for a full description of the temperature sensor control designations.

Alarm Mask: ENABLE or DISABLE

Procedure: Enable or disable the alarming of a failure of the designated control temperature sensor as required.



IMPORTANT: This alarm should always be enabled. If the controller experiences a Control TS Failure it will turn the output off or on (as specified by TS FAIL MODE) until this alarm is cleared.

5.5 OTHER ALARMS CONFIGURATION

This section defines the non-temperature-related alarming functions of the 910 controller (current, ground fault, voltage and resistance).

5.5.1 LOW LOAD CURRENT ALARM

Purpose: Alarms current levels which are lower than a preset limit for the application. Monitoring for lower than expected current levels may be an effective means of continuity monitoring. See also HIGH RESISTANCE ALARM in Section 5.5.14.

Alarm Mask: ENABLE or DISABLE

Range: 0.3 to 100.0 Amps

Procedure: Adjust the LOW CURRENT ALARM level to the desired value. Note that the LOW CURRENT ALARM must be enabled in order to adjust the LOW CURRENT ALARM level.



IMPORTANT:

- For series type heating cables, adjusting the LOW CURRENT ALARM to 50% of full load current will properly alarm a problem and reduce nuisance alarms due to voltage dips. Parallel heaters should be adjusted to a level as close as possible to full load current but lower than the current at worst case voltage. The low current setting as a percentage of full load current will vary depending on the facility and its power system.
- A LOW CURRENT ALARM may also result from a switch failed open. The controller cannot detect a switch failure due to no current. A no current condition would be identified by a LOW CURRENT ALARM (if enabled) and the analog value reported with the alarm will be 0.0 A.
- It may be advantageous to consider using the HIGH RESISTANCE ALARM to indicate a cable fault when using certain types of heaters. See Sections 5.5.12 and 5.5.14 for an explanation of the resistance alarming feature.

5.5.2 LOW LOAD CURRENT ALARM FILTER TIME SETTING

Purpose: The LOW CURRENT ALARM FILTER will prevent LOW LOAD CURRENT ALARMS from being indicated until a low current condition has existed for the duration of the LOW CURRENT ALARM FILTER time.

Range: 0 to 12 seconds

Procedure: Adjust the LOW CURRENT ALARM FILTER time to the desired value. Note that the LOW CURRENT ALARM must be enabled in order to adjust the LOW CURRENT ALARM FILTER time.



IMPORTANT:

- If an alarm condition appears and then disappears before the alarm filter time has expired, the filter timer is reset and the alarm condition must exist again for the entire alarm filter time before the corresponding alarm will be indicated.
- If the user resets an alarm while the alarm condition is still exists, then the alarm will not be indicated again until the entire alarm filter time has expired.

5.5.3 HIGH LOAD CURRENT ALARM

Purpose: Alarms current levels which are higher than a preset limit for the application.

Alarm Mask: ENABLE or DISABLE

Range: 0.3 to 100.0 Amps

Procedure: Adjust the HIGH CURRENT ALARM level to the desired value. Note that the HIGH CURRENT ALARM must be enabled in order to adjust the HIGH CURRENT ALARM level.



IMPORTANT: As the HTC automatically protects itself from overload, it would not normally be necessary to enable this alarm. This automatic protection can be used effectively to guard against accidental paralleling of heating circuits. In-rush, or cold start currents typically associated with self-regulating cables, may cause nuisance HIGH CURRENT ALARMS. If this is undesirable this alarm should be disabled.

5.5.4 HIGH LOAD CURRENT ALARM FILTER TIME SETTING

Purpose: The HIGH CURRENT ALARM FILTER will prevent HIGH LOAD CURRENT ALARMS from being indicated until a high current condition has existed for the duration of the HIGH CURRENT ALARM FILTER time.

Range: 0 to 12 seconds

Procedure: Adjust the HIGH CURRENT ALARM FILTER time to the desired value. Note that the HIGH CURRENT ALARM must be enabled in order to adjust the HIGH CURRENT ALARM FILTER time.



IMPORTANT:

- If an alarm condition appears and then disappears before the alarm filter time has expired, the filter timer is reset and the alarm condition must exist again for the entire alarm filter time before the corresponding alarm will be indicated.
- If the user resets an alarm while the alarm condition is still exists, then the alarm will not be indicated again until the entire alarm filter time has expired.

5.5.5 HIGH GROUND FAULT CURRENT ALARM

Purpose: Alarms ground fault current levels which are higher than a preset limit for the application.

Alarm Mask: ENABLE or DISABLE

Range: 20 to 250 mAmps

Procedure: Adjust the HIGH GFI ALARM level to the desired value. Note that the HIGH GFI ALARM must be enabled in order to adjust the HIGH GFI level.

5.5.6 HIGH GROUND FAULT CURRENT ALARM FILTER TIME SETTING

Purpose: The HIGH GFI ALARM FILTER will prevent HIGH GFI ALARMS from being indicated until a high GFI condition has existed for the duration of the HIGH GFI ALARM FILTER time.

Range: 0 to 12 seconds

Procedure: Adjust the HIGH GFI ALARM FILTER time to the desired value. Note that the HIGH GFI ALARM must be enabled in order to adjust the HIGH GFI ALARM FILTER time.



IMPORTANT:

- If an alarm condition appears and then disappears before the alarm filter time has expired, the filter timer is reset and the alarm condition must exist again for the entire alarm filter time before the corresponding alarm will be indicated.
- If the user resets an alarm while the alarm condition is still exists, then the alarm will not be indicated again until the entire alarm filter time has expired.

5.5.7 GROUND FAULT TRIP ALARM

Purpose: This value sets the upper limit of allowable ground fault leakage current. Exceeding this limit will result in the output switch being latched off and the GFI TRIP ALARM activated to indicate a ground fault condition.

Alarm Mask: ENABLE or DISABLE

Range: 20 to 250 mAmps

Procedure: If ground fault tripping is desired, enable the GFI TRIP ALARM and adjust the G.F. TRIP CURRENT to the desired value. To disable ground fault tripping, disable the alarm. Note that the

GFI TRIP ALARM must be enabled in order to adjust the G.F. TRIP CURRENT level.

 **CAUTION:**

In order to implement a ground fault trip function, ALL NON-GROUNDED power conductors must be opened upon detection of a ground fault condition.



IMPORTANT: National Electrical Codes may require that all legs of non-neutral based power sources be opened upon detection of a Ground Fault. Multi-pole switch configurations should be used on non-neutral based power systems. Check the requirements with your local Electrical Authority.

5.5.8 LOW VOLTAGE ALARM

Purpose: Alarms voltage levels that are lower than a preset limit for the application.

Alarm Mask: ENABLE or DISABLE

Range: 10 to 330 Volts

Procedure: Adjust the LOW VOLTAGE ALARM level to the desired value. Note that the LOW VOLTAGE ALARM must be enabled in order to adjust the LOW VOLTAGE ALARM level.



IMPORTANT: It is recommended that the LOW VOLTAGE ALARM always be enabled.

5.5.9 LOW VOLTAGE ALARM FILTER TIME SETTING

Purpose: The LOW VOLTAGE ALARM FILTER will prevent LOW VOLTAGE ALARMS from being indicated until a low voltage condition has existed for the duration of the LOW VOLTAGE ALARM FILTER time.

Range: 0 to 12 seconds

Procedure: Adjust the LOW VOLTAGE ALARM FILTER time to the desired value. Note that the LOW VOLTAGE ALARM must be enabled in order to adjust the LOW VOLTAGE ALARM FILTER time.



IMPORTANT:

- If an alarm condition appears and then disappears before the alarm filter time has expired, the filter timer is reset and the alarm condition must exist again for the entire alarm filter time before the corresponding alarm will be indicated.
- If the user resets an alarm while the alarm condition is still exists, then the alarm will not be indicated again until the entire alarm filter time has expired.

5.5.10 HIGH VOLTAGE ALARM

Purpose: Alarms voltage levels that are higher than a preset limit for the application. Serves as a monitor of the voltage used to power the tracing circuit.

Alarm Mask: ENABLE or DISABLE

Range: 10 to 330 Volts

Procedure: Adjust the HIGH VOLTAGE ALARM level to the desired value. Note that the HIGH VOLTAGE ALARM must be enabled in order to adjust the HIGH VOLTAGE ALARM level.

5.5.11 HIGH VOLTAGE ALARM FILTER TIME SETTING

Purpose: The HIGH VOLTAGE ALARM FILTER will prevent HIGH VOLTAGE ALARMS from being indicated until a high voltage condition has existed for the duration of the HIGH VOLTAGE ALARM FILTER time.

Range: 0 to 12 seconds

Procedure: Adjust the HIGH VOLTAGE ALARM FILTER time to the desired value. Note that the HIGH VOLTAGE ALARM must be enabled in order to adjust the HIGH VOLTAGE ALARM FILTER time.

IMPORTANT:

- If an alarm condition appears and then disappears before the alarm filter time has expired, the filter timer is reset and the alarm condition must exist again for the entire alarm filter time before the corresponding alarm will be indicated.
- If the user resets an alarm while the alarm condition is still exists, then the alarm will not be indicated again until the entire alarm filter time has expired.

5.5.12 LOW RESISTANCE ALARM

Purpose: Alarms heater resistance levels that have decreased from the NOMINAL RESISTANCE setting by more than the selected amount.

Alarm Mask: ENABLE or DISABLE

Range: 1% to 100% (deviation from NOMINAL RESISTANCE)

Procedure: Adjust the LOW RESISTANCE ALARM deviation to the desired value. Note that the LOW RESISTANCE ALARM must be enabled in order to adjust the LOW RESISTANCE deviation.



IMPORTANT:

- This feature would not normally be enabled. It can be used effectively to guard against accidental paralleling of heating circuits. Care must be taken when using this alarm feature with heating cables that exhibit a variable resistance with temperature. Low resistance alarming may not be practical when the load has an increasing resistance with temperature (such as self-regulating cables).
- Use of the LOW RESISTANCE ALARM assumes that the controller power is derived from the same circuit as the tracing power (either by direct connection or through a step-down transformer).
- No LOW RESISTANCE ALARMS will be generated if the measured voltage is below the LOW VOLTAGE ALARM setpoint, regardless if the LOW VOLTAGE ALARM is enabled. This stops an alarm from being generated when the circuit power is turned off. If the LOW VOLTAGE ALARM is disabled, ensure that the LOW VOLTAGE setpoint is set to a relevant level otherwise no LOW RESISTANCE ALARMS will occur.
- LOW RESISTANCE ALARMS will only be generated if the output switch is on.

5.5.13 LOW RESISTANCE ALARM FILTER TIME SETTING

Purpose: The LOW RESISTANCE ALARM FILTER will prevent LOW RESISTANCE ALARMS from being indicated until a low resistance condition has existed for the duration of the LOW RESISTANCE ALARM FILTER time.

Range: 0 to 12 seconds

Procedure: Adjust the LOW RESISTANCE ALARM FILTER time to the desired value. Note that the LOW RESISTANCE ALARM must be enabled in order to adjust the LOW RESISTANCE ALARM FILTER time.



IMPORTANT:

- If an alarm condition appears and then disappears before the alarm filter time has expired, the filter timer is reset and the alarm condition must exist again for the entire alarm filter time before the corresponding alarm will be indicated.
- If the user resets an alarm while the alarm condition is still exists, then the alarm will not be indicated again until the entire alarm filter time has expired.

5.5.14 HIGH RESISTANCE ALARM

Purpose: Alarms heater resistance levels that have increased from the NOMINAL RESISTANCE setting by more than the selected amount. The HIGH RESISTANCE ALARM may be used to indicate an open or a high resistance connection or, when using constant wattage parallel cables, may indicate the failure of one or more heating zones. It may also be used to monitor a failed series-type cable or connection in three-phase applications while minimizing nuisance alarms created by voltage fluctuations.

Alarm Mask: ENABLE or DISABLE

Range: 1% to 250% (deviation from NOMINAL RESISTANCE)

Procedure: Adjust the HIGH RESISTANCE ALARM level to the desired value. Note that the HIGH RESISTANCE ALARM must be enabled in order to adjust the HIGH RESISTANCE deviation.

IMPORTANT:

- Using the LOW CURRENT ALARM feature to ensure that unexpected decreases in current consumption by the heating cable are alarmed is a reliable method of monitoring the integrity of series-type heating cables. When using parallel-type heaters (zoned constant wattage or self-regulating) or in three-phase installations, the LOW CURRENT ALARM setting must be chosen as close to the lowest expected current as possible to detect failed zones, or cable degradation,

or a lost phase. The problem with such a close setting is that it inevitably leads to nuisance alarms, particularly when voltage fluctuations are present. By using the HIGH RESISTANCE ALARM, nuisance alarms due to voltage dips may be minimized.

- Use of the HIGH RESISTANCE ALARM assumes that the controller power is derived from the same circuit as the tracing power.
- No HIGH RESISTANCE ALARMS will be generated if the measured voltage is below the LOW VOLTAGE ALARM setpoint, regardless of whether the LOW VOLTAGE ALARM is enabled. This stops an alarm from being generated when the circuit power is turned off.

If the LOW VOLTAGE ALARM is disabled ensure that the LOW VOLTAGE setpoint is set to a relevant level otherwise no HIGH RESISTANCE ALARMS will occur.

- HIGH RESISTANCE ALARMS will only be generated if the output switch is on.

5.5.15 HIGH RESISTANCE ALARM FILTER TIME SETTING

Purpose: The HIGH RESISTANCE ALARM FILTER will prevent HIGH RESISTANCE ALARMS from being indicated until a high resistance condition has existed for the duration of the HIGH RESISTANCE ALARM FILTER time.

Range: 0 to 12 seconds

Procedure: Adjust the HIGH RESISTANCE ALARM FILTER time to the desired value. Note that the HIGH RESISTANCE ALARM must be enabled in order to adjust the HIGH RESISTANCE ALARM FILTER time.



IMPORTANT:

- If an alarm condition appears and then disappears before the alarm filter time has expired, the filter timer is reset and the alarm condition must exist again for the entire alarm filter time before the corresponding alarm will be indicated.
- If the user resets an alarm while the alarm condition is still exists, then the alarm will not be indicated again until the entire alarm filter time has expired.

5.5.16 NOMINAL RESISTANCE SETTING

Purpose: This parameter defines the nominal expected heater resistance. A value must be entered by the user to allow the HIGH and LOW RESISTANCE ALARMS to be used. In installations where the power source may experience periodic fluctuations (surges and/or brownout conditions), alarming on resistance deviation offers an improved method of monitoring tracer integrity than simple LOW and HIGH CURRENT ALARMS. Since the ratio of voltage to current is monitored, the HIGH and LOW RESISTANCE ALARMS offer cable monitoring that is relatively immune to voltage fluctuations.

Range: 2.00 to 2000.00 Ω

Procedure: The NOMINAL RESISTANCE value can only be set if either the LOW RESISTANCE and/or the HIGH RESISTANCE ALARMS are enabled. Once the controller and the heating cable have been installed, the following procedure should be used to determine the NOMINAL RESISTANCE

Setting:

- Adjust the CONTROL SETPOINT temperature to turn on the output switch.
- Allow the load to come up to design temperature and its power consumption to stabilize.
- Using the 920 Operator Console, access the RESISTANCE reading and record its value. Return the CONTROL SETPOINT temperature to its proper setting.
- Enter the recorded resistance value as the NOMINAL RESISTANCE setting.



IMPORTANT: The setup procedure outlined above may have to be repeated a number of times to arrive at a correct nominal resistance setting. This value will be affected by the heating cable temperature, which in turn is affected by ambient temperature, insulation level, a full or empty pipe or vessel, etc.

5.5.17 OVERCURRENT TRIP ALARM (SSR ONLY)

Purpose: The overcurrent trip feature is always enabled when using an SSR output switch and is used to provide protection for the output switch. Enabling this alarm will only inform the user of an excessively high current condition and that the output switch has been latched off. During a high current condition, the controller attempts to soft start a heating cable using a technique involving measured in-rush current and the SWITCH CURRENT RATING. If the controller is unable to start

the cable, it will eventually trip its output switch off and will not retry or pulse its output switch again. At this point the OVERCURRENT TRIP ALARM is latched on.



IMPORTANT:

- The controller is NOT a safety cutout or an overcurrent protective device as defined by the National and Canadian Electrical Codes (NEC and CEC). A protective device such as a circuit breaker or fuse must be included as part of a proper design and be selected in accordance with the requirements defined in the National Electrical Code (NEC) and/or the Canadian Electrical Code (CEC).
- The controller cannot protect the SSR from short circuits or excessive overcurrent conditions. Always ensure that the power is off prior to performing any maintenance or troubleshooting of the heating circuit. Verify that no damage has occurred to the cable or the controller prior to re-energizing the circuit.

Alarm Mask: ENABLE or DISABLE

Procedure: Adjust the SWITCH CURRENT RATING setting to the actual current rating of the SSR. Enable or disable the alarm as required. Note that the OVERCURRENT TRIP ALARM does not have to be enabled in order to adjust the SWITCH CURRENT RATING setting.



IMPORTANT: It is highly recommended that this alarm be left enabled since an overcurrent trip condition would normally represent a serious problem. Note that this is a factory set alarm value and disabling the alarm does not disable the overcurrent trip function. In some applications the use of self-regulating cable will produce very high in-rush currents during cold startup. These currents may exceed the overcurrent trip limit and the controller will not be able to soft start the trace circuit. If this condition persists please contact your nearest sales office for recommendations and solutions to this problem.

5.5.18 SWITCH FAILURE ALARM

Purpose: The purpose of the SWITCH FAILURE ALARM is to indicate that an output switch failure has occurred. The controller determines that if the output switch is turned off and there is load current present, then the output switch has failed closed and the alarm is latched on.

Alarm Mask: ENABLE or DISABLE

Procedure: Enable or disable the alarming of an output switch that has failed in the closed position.



IMPORTANT: The SWITCH FAILURE ALARM SHOULD ALWAYS BE ENABLED. A high temperature condition as a result of a failed circuit can only be caused if the output switch fails closed. When an output switch fails closed, the controller cannot turn the tracer off; therefore, no protection features are available (ground fault trip, power limiting, etc.). If a SWITCH FAILURE ALARM is detected, the unit should be serviced immediately.

5.5.19 HTC RESET ALARM

Purpose: The HTC RESET ALARM is used to indicate:

1. Power to the HTC has been interrupted and subsequently restored.
2. A transient has caused the HTC's microprocessor to restart.
3. An internal condition has caused the HTC's microprocessor to restart its program.

Alarm Mask: ENABLE or DISABLE

Procedure: Enable or disable alarming on reset as desired.



IMPORTANT: Normally the HTC RESET ALARM is left disabled since powering the controller off and on for maintenance or trouble-shooting would require the user to reset this alarm every time. If the particular installation includes a Model 780/GCC-9000, this alarm may be left enabled since resets are not considered normal occurrences and the Model 780/GCC-9000 provides the capability to easily log and reset alarms such as these. The difference in time between when a COMMUNICATIONS FAIL ALARM and an HTC RESET ALARM are logged provide an indication of how long the circuit has been "OFF."

5.5.20 CIRCUIT BREAKER LIMITING STATUS (SSR ONLY)

Purpose: The circuit breaker limiting feature is always enabled when using an SSR output switch and is intended to prevent the circuit breaker immediately upstream of the controller from tripping during a temporary overcurrent condition. Enabling this alarm will only inform the user that circuit breaker limiting is currently active.

Alarm Mask: ENABLE or DISABLE

Procedure: Adjust the CIRCUIT BREAKER CURRENT RATING setting to the heating circuit breaker size (i.e. 15.0 or 20.0 Amps). Enable or disable the alarm as required. Note that the CIRCUIT BREAKER LIMITING ALARM does not have to be enabled in order to adjust the CIRCUIT BREAKER CURRENT RATING setting.



IMPORTANT:

- This is a non-latching alarm.
- This alarm may be considered an advisory alarm. If the measured current exceeds the level that would cause the upstream circuit breaker to release, the HTC will begin to switch the SSR ON and OFF rapidly to limit the average current to an acceptable level.

5-5-21 POWER LIMITING STATUS (SSR ONLY)

Purpose: The power limiting feature is always enabled when using an SSR output switch and is intended to limit the average amount of power that is applied to the trace circuit. The controller measures the voltage and current of the tracing circuit and will vary its output switch to limit the amount of power applied to the trace to the value set by the MAXIMUM POWER setting. Enabling this alarm will only inform the user that power limiting is currently active.

Alarm Mask: ENABLE or DISABLE

Procedure: Adjust the MAXIMUM POWER setting to the desired value. Enable or disable the alarm as required. Note that the POWER LIMITING ALARM does not have to be enabled in order to adjust the MAXIMUM POWER setting.



IMPORTANT:

- This is a non-latching alarm.
- This alarm may be considered more appropriately an advisory alarm and is normally disabled. It will be active if the MAXIMUM POWER setting is set below the power output level required for temperature maintenance. In other words, if the circuit demands the maximum power allowed and the alarm is enabled, then this alarm will be indicated and the output switch will pulse ON and OFF to limit the average power output to a value approximately equal to the MAXIMUM POWER setting.

5.5.22 SWITCH LIMITING STATUS (SSR ONLY)

Purpose: The switch limiting feature is always enabled when using an SSR output switch and is intended to provide protection for the output switch. Enabling this alarm will only inform the user that switch limiting is currently active and an excessively high current condition is present. The controller pulses its output switch for a small number of cycles and reads the resulting current. If the measured current exceeds the SWITCH RATING setting, then the duty-cycle of its output switch will be varied so that an average current not exceeding the SWITCH RATING setting is maintained.

Alarm Mask: ENABLE or DISABLE

Procedure: Adjust the SWITCH CURRENT RATING setting to the actual current rating of the SSR. Enable or disable the alarm as required. Note that the SWITCH LIMITING ALARM does not have to be enabled in order to adjust the SWITCH CURRENT RATING setting.



IMPORTANT:

- This is a non-latching alarm.
- This alarm should normally be enabled. Currents in this range cannot be considered normal and should be investigated.

5.5.23 CONTACTOR COUNT ALARM

Purpose: Generates an alarm if the number of off-to-on transitions of a contactor reaches or exceeds the CONTACTOR COUNT ALARM setting. This serves as a method to perform preventative maintenance on the contactor before a failure is likely to occur.

Alarm Mask: ENABLE or DISABLE

Range: 0 to 999999 off-to-on transitions

Procedure: Adjust the CONTACTOR ALARM setting to the desired value. Note that the CONTACTOR ALARM must be enabled in order to adjust the CONTACTOR ALARM setting.



IMPORTANT: The CONTACTOR ALARM is only available if the SWITCH CONTROL MODE is set to either DEADBAND or PROPORTIONAL AMBIENT CONTACTOR.

5.5.24 EEROM DATA FAILURE ALARM

Purpose: The EEROM DATA FAILURE ALARM indicates that the controller has detected a failure in its nonvolatile memory.

Alarm Mask: ENABLE or DISABLE

Procedure: Enable or disable alarming of a nonvolatile memory failure as desired.



IMPORTANT: The EEROM DATA FAILURE ALARM should always be enabled. This memory stores all of the controller's configuration and calibration settings and the alarm will only be generated if the microprocessor cannot bypass the failed area of its memory. This indicates an internal problem and the 910 should be replaced and returned to the factory for repair.

5.6 COMMUNICATIONS SETUP

The following section describes the setup parameters that relate to the way in which the controller is to communicate with another device. If the optional communications interface is not installed in the 910 Control Module, these parameters need not be configured.

5.6.1 PROTOCOL

Purpose: Defines the communications language used by the controller to communicate with other devices.

Setting: HTCBUS™ or MODBUS ASCII or MODBUS RTU

Procedure: Select the HTCBUS™ protocol when communicating with existing Pyrotenax Heat Trace Control products, including the Model 780/GCC-9000 Group Communications Controller.

If you are communicating directly with the controller using a different device, select the MODBUS protocol. For a detailed description of the controller's MODBUS mapping please refer to 910 Series Heat Trace Controller—Modbus Protocol Interface document.

5.6.2 HTCBUS™ ADDRESS

Purpose: Defines the communications address to be used by the controller when using the HTCBUS™ protocol to communicate with a Model 780/GCC-9000.

Range: 1 to 16,777,215

Procedure: Set the communications address as desired. This must be an address unique to the entire communications network to avoid messaging conflicts. The HTCBUS™ protocol must be selected in order to set the HTCBUS™ ADDRESS.



IMPORTANT: A unique HTCBUS™ communications address is always assigned by the Factory and identified by the label on the top of the controller module (see Fig. 2.1). It is recommended that the pre-assigned address be used whenever possible to minimize the chances of an address being duplicated in the user's system.

5.6.3 MODBUS ADDRESS

Purpose: The MODBUS ADDRESS along with the MODBUS SUB ADDRESS define the communications address to be used by the controller when using either MODBUS protocol to communicate with a MODBUS compatible device.

Range: 1 to 247

Procedure: Set the communications address as desired. Together with the MODBUS SUB ADDRESS, this combination must be unique to the entire communications network to avoid messaging conflicts. Either MODBUS protocol must be selected in order to set the MODBUS ADDRESS.

5.6.4 MODBUS SUB ADDRESS

Purpose: The MODBUS SUB ADDRESS along with the MODBUS ADDRESS define the communications address to be used by the controller when using either MODBUS protocol to communicate with a MODBUS compatible device.

Range: 0 to 31

Procedure: Set the communications sub address as desired. Together with the MODBUS ADDRESS, this combination must be unique to the entire communications network to avoid messaging conflicts. Either MODBUS protocol must be selected in order to set the MODBUS SUB ADDRESS.



IMPORTANT: Since a 910 HTC does not use all 65,535 data registers that are available for each MODBUS ADDRESS, the data register range is subdivided to allow up to 32 HTCs to share the same MODBUS ADDRESS. This increases the number of HTCs allowed on a single Modbus port from 247 to 7,904 (= 247 x 32). This requires that any HTC sharing the same MODBUS ADDRESS as another HTC must have its own unique MODBUS SUB ADDRESS.

5.6.5 BAUD RATE

Purpose: Defines the data rate at which communications occur.

Setting: AUTO or 9600 or 4800 or 2400 or 1200 or 600 or 300

Procedure: Select the data rate to be compatible with other devices that will be connected to the controller for communications purposes.



IMPORTANT: Not all communications interfaces will support the various data rates—it is recommended that the setting be set to AUTO. The controller will automatically select a BAUD RATE that is compatible with the communications interface installed. If BAUD RATE = AUTO and a MODEM communication interface is used then a data rate of 300 will always be used. Otherwise, if BAUD RATE = AUTO and a non-MODEM communication interface is used the PROTOCOL is either MODBUS protocol then a data rate of 9600 is used.

5.6.6 PARITY (MODBUS)

Purpose: Defines the type of parity bit to be used with MODBUS communications.

Setting: NONE or ODD or EVEN

Procedure: Select the desired type of parity. Note that PARITY can only be selected when using either MODBUS protocol.

5.6.7 HARDWARE

Purpose: Identifies the type of communications interface installed in the 910. The controller will automatically determine and display which communications interface type is available.

Values: NONE, MODEM or RS-232 or RS-485

5.6.8 DRIVER

Purpose: Defines the way in which the controller's program communicates with the communications interface.

Setting: AUTO or RS-232 or RS-485 or MODEM

Procedure: It is recommended that the setting be set to AUTO—this will allow the controller to automatically choose the setting to match the type of communications interface installed.

5.6.9 PROFILE

Purpose: Defines the way in which the controller's program supports communications handshaking and communication interface signals.

Setting: AUTO or

3-WIRE RS-232 or

RS-485 or

1200 BAUD MODEM or

300 BAUD MODEM

Procedure: Select the PROFILE to be compatible with other devices that will be connected to the controller for communications purposes. It is recommended that the setting be set to

AUTO. The controller will automatically select a profile based on the type of communications interface installed in the 910.



IMPORTANT:

- AUTO: Selects a communications profile based on the data rate and the type of communications interface installed in the 910.
- 3-WIRE RS-232: Continuously asserts the internal RTS signal. Internal CTS and DCD signals are ignored. The Tx Delay timer is active. This is the profile used when PROFILE = AUTO and an RS-232 communication interface is used with the 910.
- RS-485: Uses the internal RTS signal and the Tx Delay timer. Internal CTS and DCD signals are ignored. This is the profile used when PROFILE = AUTO and an RS-485 communication interface is used.
- 1200 BAUD MODEM: Uses the internal RTS signal with a fixed 10 msec Tx Delay time, ignores the internal CTS signal. Uses the internal DCD signal to qualify each receive data character. This is the profile used when PROFILE = AUTO, BAUD RATE = 1200 and a MODEM communication interface is used.
- 300 BAUD MODEM: Uses the internal RTS signal with a fixed 30 msec Tx Delay time, ignores the internal CTS signal, uses the internal DCD signal to qualify each receive data character. This is the profile used when PROFILE = AUTO, BAUD RATE is not 1200 and a MODEM communication interface is used.

5.6.10 TX DELAY

Purpose: Allows a programmable delay between the receipt of a communications message and the controller's reply. In some applications, it may be necessary to delay the controller's response to an inquiry for a short period of time to allow external devices to start up, stabilize and/or synchronize.

Range: 0.00 to 2.50 seconds

Procedure: Set the amount of delay between the receipt of a message and the controller's response as required.



IMPORTANT: This selectable TX DELAY is only used if the PROFILE is set to either RS-485 or AUTO and an RS-485 interface is installed.

5.7 OPERATOR CONSOLE FUNCTIONS

The following features are part of the controller's programming, but are only used in conjunction with the Operator Console.

5.7.1 PASSCODE

Purpose: The four digit, numeric PASSCODE feature stops unauthorized users from modifying the controller's configuration parameters using the Operator Console.

Range: 0000 to 9999

Procedure: Enter the desired PASSCODE (in the "Miscellaneous Common Setup" submenu) using the Operator Console keypad. A PASSCODE of 0000 disables the lockout feature and allows all configuration parameters to be modified using the Operator Console without requiring a PASSCODE. Setting the PASSCODE to any other value will require the database to be unlocked by entering the correct PASSCODE prior to modifying any of the controller's configuration parameters using the Operator Console.



IMPORTANT: The PASSCODE can be edited only if it is set to 0 or the database has been unlocked by entering the proper PASSCODE.

5.7.2 LOCK DATABASE

Purpose: If the PASSCODE has been enabled (PASSCODE is not set to 0) and the user has unlocked console modification access to the controller's configuration parameters, the LOCK DATABASE feature allows the user to re-lock this modification access once programming has been completed.

Procedure: Select the LOCK DATABASE function (at the end of the "Configuration Mode Main

Menu”) to lock out Operator Console configuration modification access. The display will confirm the operation by displaying a “DATABASE LOCKED” message.



IMPORTANT: Operator Console configuration modification access will automatically re-lock after approximately 5 minutes of keypad inactivity.

5.7.3 UNLOCK DATABASE

Purpose: If a PASSCODE has been enabled (PASSCODE is not set to 0) and the user wants to modify any of the controller’s configuration parameters using a the Operator Console, then the database must first be unlocked.

Procedure: Try modifying any configuration parameter, or select the UNLOCK DATABASE function (at the end of the “Configuration Mode Main Menu”), and a prompt for the PASSCODE will appear. If the correct PASSCODE is entered then the display will confirm the operation by displaying a DATABASE UNLOCKED message.

5.7.4 TEST TRACING

Purpose: The TEST TRACING feature provides an easy method of temporarily overriding the temperature control, without having to modify the CONTROL SETPOINT temperature or any other configuration parameter.

Procedure: Press the TEST key on the Operator Console or select the TEST TRACING function to force the output switch on for approximately 30 seconds. After the test time has expired, the unit will automatically revert back to normal operation.



IMPORTANT:

- This feature only overrides temperature control; it does not override other control parameters such as power limiting.
- If load shedding is active then TEST TRACING is inhibited.

5.7.5 DISPLAY TEST

Purpose: The DISPLAY TEST feature provides an easy method of illuminating each display segment and all the LEDs of the Operator Console to ensure that they are functioning properly.

Procedure: Select DISPLAY TEST and watch the Operator Console to verify that each display segment and each LED is illuminated during the test sequence.

Note: Pressing any key on the Operator Console keypad during the DISPLAY TEST will cause the DISPLAY TEST to abort.

5.7.6 LOAD DEFAULTS

Purpose: To provide a quick method of setting all of the controller’s configuration parameters to the factory default configuration parameters, as defined in Appendix G. In addition, all of the maintenance data parameters are reset. Note that all load shedding parameters (including fail safe) are configured with default values. The CONSOLE SETPOINT MAXIMUM and MINIMUM are also configured with default values.

Procedure: Select the LOAD DEFAULTS function (in the “Miscellaneous Setup” submenu) using the Operator Console keypad.



IMPORTANT: This function will also overwrite the communication configuration parameters, which could affect existing communications to the controller.

5.7.7 FEATURE MODE

Purpose: Provides two types of menus on the Operator Console for configuring the 910.

Setting: BASIC or ADVANCED

Procedure: Select BASIC if access to only the seven most common parameters is required. Select ADVANCED if access to all of the 910 parameters is required.

SECTION 6—MONITORED PARAMETER DETAILS

6.1 INTRODUCTION

The following text provides a brief summary of each of the measured and calculated parameters that the 910 Series Control Module provides to the user. Detailed information regarding settings, alarms limits, etc. may be found in Section 5 of this manual.

Detailed information regarding the display of these variables using the Operator Console may be found in Section 4.2 of this manual.

For detailed information regarding the display of these variables using the Model 780/GCC-9000, refer to the GCC user manual.

6.2 ANALOG READINGS

6.2.1 CONTROL TEMPERATURE

Purpose: This is the temperature that the controller uses to determine whether its output switch should be on or off. Depending on the TS CONTROL MODE setting and whether one or two RTDs are installed, the CONTROL TEMPERATURE may be derived from TS 1 or TS 2, or a combination of the two temperatures. See Section 5.2.11 of this manual for further details regarding the TS CONTROL MODE settings.

6.2.2 TS 1 TEMPERATURE

Purpose: This temperature is the value that the controller is reading from the RTD connected to its TS 1 input. Depending on the TS CONTROL MODE, it may be used to determine the CONTROL TEMPERATURE (see Section 6.2.1 above).



IMPORTANT: If the TS 1 input is not being used by the controller, the TS 1 TEMPERATURE is not displayed.

6.2.3 TS 2 TEMPERATURE

Purpose: This temperature is the value that the controller is reading from the RTD connected to its TS 2 input. Depending on the TS CONTROL MODE, it may be used to determine the CONTROL TEMPERATURE (see Section 6.2.1 above).

Note: If the TS 2 input is not being used then by the controller then the TS 2 TEMPERATURE is not displayed.

6.2.4 LOAD CURRENT

Purpose: The LOAD CURRENT reading indicates the average current being drawn by the heating cable.

6.2.5 RESISTANCE

Purpose: Resistance is calculated using the average adjusted voltage reading divided by the average adjusted current reading to yield a load resistance in ohms. If the controller's output switch is on, but no current is present, the RESISTANCE will read "open circuit."



IMPORTANT: If the controller's output switch is off, the RESISTANCE will always display the last resistance which was calculated while the output switch was last on.

6.2.6 GROUND FAULT CURRENT

Purpose: If the controller detects any leakage current in the output circuit, it will indicate the level in milliamps.



IMPORTANT: To minimize nuisance alarms, the controller will not report a leakage current of less than 20 mAmps.

6.2.7 VOLTAGE

Purpose: The voltage reading indicates the average circuit voltage being measured by the 910.

6.2.8 POWER

Purpose: Load power provides an indication of the average power being consumed by the heat trace cable .



IMPORTANT: The controller calculates load power by multiplying the average adjusted voltage reading by the average adjusted current reading.

6.3 MAINTENANCE DATA

6.3.1 MAX / MIN TEMPERATURE VALUES

MAX CONTROL TEMP
MIN CONTROL TEMP
TS 1 MAX TEMP
TS 1 MIN TEMP
TS 2 MAX TEMP
TS 2 MIN TEMP

Purpose: This feature indicates the maximum and minimum temperatures recorded by the HTC since the last time the values were reset. It may be useful to log the maximum/minimum temperatures experienced on a particular tracing circuit for the purposes of troubleshooting or gathering data for future design criteria. The temperature values are written to the controller's non-volatile memory once every 24 hours or whenever any maintenance data is reset by the user. Max/min temperatures are recorded for TS 1, TS 2 and the CONTROL TS.

Range: Can only be reset (cleared) by the operator.

Procedure: The max/min temperatures may be reset using the Operator Console or a communicating device. Resetting any one of the temperatures will reset all of them.

6.3.2 POWER ACCUMULATOR

Purpose: This feature indicates the total power consumption of the trace circuit since the last time the POWER ACCUMULATOR was reset. It may be useful to log the amount of power consumed on a particular trace circuit for the purposes of energy management or gathering of data for future design criteria. The value of this accumulator is written to the controller's non-volatile memory once every 24 hours or whenever any maintenance data is reset by the user.

Procedure: The POWER ACCUMULATOR may be reset to zero using the Operator Console or a communicating device.



IMPORTANT: The POWER ACCUMULATOR value will roll over to zero when the upper limit of the POWER ACCUMULATOR has been exceeded. This upper limit is 214,748,364.7 kW-hours.

6.3.3 CONTACTOR CYCLE COUNTER

Purpose: This feature indicates the total number of off-to-on transitions a contactor has made since the last time the CONTACTOR CYCLE COUNTER was reset. This serves as a method to perform preventative maintenance on the contactor according to the manufacturer's specifications. This count value is written to the controller's nonvolatile memory once every 24 hours or whenever any maintenance data is reset by the user.

Procedure: The CONTACTOR CYCLE COUNTER may be reset to zero using the Operator Console or a communicating device.



IMPORTANT:

- Once the CONTACTOR CYCLE COUNTER reaches 999,999,999 it will stop counting.
- The CONTACTOR CYCLE COUNTER is only indicated if the SWITCH CONTROL MODE is set to either DEADBAND or PROPORTIONAL AMBIENT CONTACTOR.

6.3.4 TIME IN USE

Purpose: The purpose of this feature is to indicate the total hours in use of the controller since its initial operation. It may be useful to log the amount of time a particular controller has been in operation for the purposes of maintenance planning or reliability testing. The value of this accumulator is written to the controller's nonvolatile memory once every 24 hours or whenever any maintenance data is reset by the user.



Procedure: The IN USE hours accumulator can be reset to zero using the Operator Console or a communicating device.

IMPORTANT: The IN USE hours accumulator value will roll over to zero when the upper limit of the accumulator has been exceeded. This limit is 999,999,999 hours.

6.3.5 TIME SINCE LAST RESET

Purpose: This feature indicates the total hours in use of the controller since the last reset. It may be useful to log the amount of time a particular controller has been in operation since the last time the controller's power was cycled for trouble-shooting purposes.

Procedure: The TIME SINCE LAST RESET hours accumulator can only be reset by cycling the controller's power.

Note: The TIME SINCE LAST RESET will roll over to zero when the upper limit of 65,535 hours has been exceeded.



6.3.6 PEAK LOAD CURRENT

IMPORTANT: The PEAK LOAD CURRENT is not displayed on the Operator Console.

Purpose: This feature indicates the highest instantaneous load current measured since the last time the PEAK LOAD CURRENT was reset. This value is written to the controller's nonvolatile memory once every 24 hours or whenever any maintenance data is reset by the user.

Procedure: The PEAK LOAD CURRENT may only be reset to zero using a communicating device.



6.3.7 PEAK GROUND FAULT CURRENT

IMPORTANT: The PEAK GROUND FAULT CURRENT is not displayed on the Operator Console.

Purpose: This feature indicates the highest instantaneous ground fault current measured since the last time the PEAK GROUND FAULT CURRENT was reset. This current value is written to the controller's non-volatile memory once every 24 hours or whenever any maintenance data is reset by the user.

Procedure: The PEAK LOAD CURRENT may only be reset to zero using a communicating device.



6.3.8 EXTERNAL INPUT STATUS

IMPORTANT: The EXTERNAL INPUT STATUS is not displayed on the optional Operator Console.

Purpose: This feature indicates the actual status of the external input regardless of the controller's configuration. This may be useful if the user wishes to use the controller's external input to monitor the status of an external dry contact and pass this on to another device.

Procedure: The EXTERNAL INPUT STATUS may only be viewed using a communicating device.

SECTION 7—CONTROL MODES

7.1 INTRODUCTION

There are several different types of control modes in the controller. Some of these modes require further explanation in order to fully understand and implement their operation.

This section describes the control modes available in the HTC and how to set their associated parameters.

7.2 SWITCH CONTROL MODES

There are four different SWITCH CONTROL modes associated with the HTC. The following is an explanation of their implementation in the controller and the differences between them.

7.2.1 PROPORTIONAL CONTROL (FOR USE WITH SSRS ONLY)

Proportional control on the HTC is implemented as follows:

- When using SSRs to directly control the power applied to a trace circuit, the output may be switched on/off very rapidly. The controller implements proportional temperature control on a cycle by cycle basis (50 or 60 Hz power line cycle).
- This algorithm monitors the temperature of the heating circuit and compares it to the CONTROL SETPOINT temperature. If the temperature of the control sensor is at or below the CONTROL SETPOINT temperature, then power is applied to the trace with a duty cycle of 100%—the controller output is full on.
- If the temperature sensed by the control sensor is equal to or greater than the CONTROL SETPOINT temperature + the PROPORTIONAL BAND setting, then the controller output will have a duty cycle of 0%—the output will be off.
- The temperature of the control sensor is constantly monitored and the output duty cycle is adjusted proportionally according to where the temperature falls within the 0%–100% band.

Proportional Control Temperature Band

Control Sensor Temperature	Duty Cycle
Setpoint + proportional band	0%
Setpoint + proportional band/2	50%
Setpoint	100%

7.2.2 DEADBAND CONTROL (FOR USE WITH EXTERNAL CONTACTORS)

Deadband control on the HTC is implemented as follows:

- When using the HTC in an application where the controller is used to open and close a contactor, proportional control cannot be used since this would cycle the contactor too quickly. In these situations, a deadband control algorithm is used. The output duty cycle is not controlled, instead the output is either fully on or completely off. The user may set the DEADBAND value.
- The controller monitors the temperature of the trace circuit and compares it to the CONTROL SETPOINT temperature as in the proportional control mode. If the control sensor temperature is above the CONTROL SETPOINT temperature by more than the DEADBAND value, the output is turned off.
- If the control sensor temperature falls below the CONTROL SETPOINT temperature the output is turned on.

This is a very simple control algorithm but it works very effectively in heat trace applications where the temperature of a traced system changes relatively slowly.

Deadband Control Temperature Band

Control Sensor Temperature	Output State
Setpoint + deadband	Off
Setpoint	On

When the control sensor temperature is within the deadband, the output does not change its state. Also, when using deadband control, a contactor is not allowed to toggle faster than every two seconds. If an AC alarm with an alarm filter time greater than 0 is detected, the contactor will not toggle until the alarm filter time has expired.

7.2.3 PROPORTIONAL AMBIENT SSR CONTROL (FOR USE WITH SSRS ONLY)

When an HTC using an SSR is used to control the output using the ambient temperature, this control mode should be used.

Proportional ambient SSR control on the HTC is implemented as follows:

- When using SSRs to directly control the power applied to a heating circuit, the output may be switched on/off very rapidly. The controller implements proportional temperature control on a cycle by cycle basis (50 or 60 Hz power line cycle).
- This algorithm monitors ambient temperature and compares it to the CONTROL SETPOINT temperature. If the temperature of the control sensor is at or below the CONTROL SETPOINT temperature minus the PROPORTIONAL BAND setting, then power is applied to the trace with a duty cycle of 100%—the controller output is fully on.
- If the temperature sensed by the control sensor is equal to or greater than the CONTROL SETPOINT temperature, then the output will have a duty cycle of 0%—the controller output will be off.
- The temperature of the control sensor is constantly monitored and the output duty cycle is adjusted proportionally according to where the temperature falls within the 0%–100% band.

Proportional Ambient SSR Control Temperature Band

Control Sensor Temperature	Duty Cycle
Setpoint	0%
Setpoint - proportional band/2	50%
Setpoint - proportional band	100%



IMPORTANT: The load shedding “fail safe mode” is not supported when using proportional ambient SSR control, since ambient temperature is being monitored rather than pipe temperature.

7.2.4 PROPORTIONAL AMBIENT CONTACTOR CONTROL (FOR USE WITH CONTACTORS)

When an HTC using a contactor is used to control the output based on the ambient temperature, this control mode should be used.

Proportional ambient contactor control on the HTC is implemented as follows:

- The output may not be switched on/off rapidly when using a contactor, so proportional temperature control is implemented by applying the required duty cycle over the selected CYCLE TIME.
- The output is fully on for a portion of the CYCLE TIME as determined by the calculated duty cycle, and it will be completely off for the remainder of the CYCLE TIME.
- The duty cycle is calculated each time the output toggles, based on the ambient temperature, PROPORTIONAL BAND setting, and the CONTROL SETPOINT temperature setting.
- The controller monitors the ambient temperature and compares it to the CONTROL SETPOINT temperature as in proportional ambient SSR control. If the temperature of the control sensor is at or below the CONTROL SETPOINT temperature minus the PROPORTIONAL BAND setting, then power is applied to the trace with a duty cycle of 100%. The controller output will be fully on for 1/30 of the CYCLE TIME setting before the duty cycle is calculated again.
- If the temperature sensed by the control sensor is equal or greater than the CONTROL SETPOINT temperature, then the output will have a duty cycle of 0%. The controller output will be off for 1/30 of the CYCLE TIME setting before the duty cycle is calculated again.

Proportional Ambient Contactor Control Temperature Band

Control Sensor Temperature	Duty Cycle
Setpoint	0%
Setpoint - proportional band/2	50%
Setpoint - proportional band	100%



IMPORTANT: The load shedding “fail safe mode” is not supported when using proportional ambient contactor control, since ambient temperature is being monitored rather than pipe temperature. Also note that if an AC alarm, with an alarm filter time greater than 0, is detected the contactor will not toggle until the alarm filter time has expired.

7.3 LOAD SHEDDING CONTROL MODE

Load shedding is a control mode that may be programmed and initiated only by an external communicating device or by the Model 780/GCC-9000 Group Communications Controller, which overrides temperature control and forces the output of the controller OFF until reset by the 780/GCC-9000. When using a GCC, load shedding is initiated by a contact closure (or opening) on one of the four contact inputs on the GCC. Each contact input initiates a load shedding command for the group of controllers associated with that contact input. Each controller may be associated with one or more groups. Refer to the Load Shedding Section in the GCC manual for details on setting up the load shedding features of the HTC when using a GCC.

When power is applied to the controller, it determines if load shedding mode has been enabled. If enabled, the controller immediately enters load shedding operation (holding its output off) and waits to see if the GCC or an external communicating device has initiated a load shedding command. If no command is present, the controller resumes normal operation. If a load shedding command is present, the controller will continue to hold its output OFF, until one of three conditions occurs:

1. The GCC contact input or zone definition bits of an external communicating device that initiated load shedding clears and the command to terminate load shedding mode is issued.
2. Communications are interrupted between the controller and its communicating device (as in the case of a damaged communications wire). Approximately 30 seconds after communications ceases, the controller will return to normal operation.
3. Communications between the controllers and the external communicating device go offline for approximately two minutes (as occurs when the 760 Hand Held Programmer is used to communicate with the controller).



IMPORTANT: The controller will return to normal operation if communications between the GCC or external communicating device and the controller is disrupted in any way. This will return temperature control to the HTC. Also, the HTC does not perform a periodic autocycle test while operating in load shed mode. When using a GCC it must be configured for load shedding operation before the controller may be set up for load shedding control.

There are three parameters that must be set up in the controller to completely configure it for load shedding operation:

1. The load shedding feature must be enabled.
2. The FAIL SAFE MODE parameter must be enabled or disabled depending on the application requirements. If FAIL SAFE MODE is enabled, then at least one LOW TS ALARM (of a TS used in the TS CONTROL MODE) must be enabled and its alarm temperature must be less than the CONTROL SETPOINT temperature; otherwise, fail safe mode will be disabled.
3. The GCC contact input(s) or zone definition bits of an external communicating device that are to be associated with the load shedding action for the controller must be defined.

These parameters may only be configured using an external communicating device or the Model 780/GCC-9000 Group Communications Controller. Refer to the Model 780/GCC-9000 user manual for details on how to set up these options. Note that the Operator Console may be used to enable or disable the load shedding feature but not set any of the other load shedding parameters.



IMPORTANT:

- Fail safe mode is always disabled if the SWITCH CONTROL MODE is set to either of the two proportional ambient control modes, or the TS CONTROL MODE = EXT. INPUT, FAIL OFF/ON.
- If the TS CONTROL MODE uses both TS 1 and TS 2 to calculate the control temperature, the HTC will turn on its output if the following conditions are met:
 - load shedding is active
 - fail safe mode is enabled
 - the control temperature falls below either of the LOW TS ALARM settings
 - both TS 1 and TS 2 have their LOW TS ALARMS enabled
- A FORCE ON override signal has higher priority than a load shedding signal. An INHIBIT signal has higher priority than fail safe mode.

SECTION 8—TROUBLESHOOTING

8.1 OPERATOR CHECKS



IMPORTANT: If the controller does not operate properly and is being returned to Pentair Industrial Heat Tracing Solutions for service, information must be provided as to why the unit was removed from service. Contact the Pentair Industrial Heat Tracing Solutions customer service department for a Return Authorization form and number prior to returning any units for repair.

Upon receipt of the controller, or to check the controller for an indication of normal operation, follow the operational procedures shown below. These procedures are designed to familiarize the operator with the controller and to provide an understanding of its operation.

In order to determine if a fault is associated with the heat tracing, wiring or the controller, it will be necessary to troubleshoot the wiring and tracer circuit. If the fault remains, remove power from the controller and exchange it with another controller. This may require some reprogramming of the new HTC. Refer to the following sections for the appropriate topic.

If the fault clears, exchange the controller on another circuit to determine if the fault moves with the controller. If the fault moves with the controller, verify that the HTC has been configured correctly for the application. If the configuration is correct it may be necessary to return the controller to Pentair Industrial Heat Tracing Solutions for evaluation.

8.1.1 GETTING STARTED

In order to access the functions of the 910 Series HTC, use the Operator Console. If the modem communications option is installed in the 910, the Model 780/GCC-9000 Group Communications Controller may also be used to access controller parameters. Refer to the GCC User Manual for operational details.

8.2 COMMON PROBLEM AREAS

The HTC may be used as an effective troubleshooting tool to pinpoint problem areas of heat trace circuits. Described below are a few of the more common problem areas, their symptoms, and parameters to check to determine the actual faulty portion of the heat trace circuit.

8.2.1 RTDS

RTD failures after installation can generally be attributed to incorrect wiring or improper installation of the sensor. Troubleshooting of these failures is a very simple procedure if the proper steps are undertaken in the correct order. Some specific RTD problems and the correct methods for troubleshooting are outlined as follows.

1. TS Failure Alarm(s)

If the HTC controller indicates a failure of an RTD:

- Ensure that the RTD is a 3-wire 100 (Platinum Type (for V3.00)). For V3.11 and up ensure that the TS TYPE setting matches the RTD being used.
TURN THE POWER TO THE CONTROLLER OFF BEFORE PROCEEDING!!
- Disconnect the RTD wiring from the input terminals.
- Measure the RTD's resistance between the source (WHT) and sense (WHT) leads at the controller (it should not exceed 40 Ω). Excessive lead resistance will cause a TS FAILURE ALARM and must be corrected. Look for loose terminals, excessive lead length, or insufficient wire gauge and correct as necessary.
- Measure the RTD's resistance between the source (WHT) or sense (WHT) lead and the common (RED) lead of the RTD at the controller (should be between 60 and 330 Ω depending on the temperature and the lead resistance. See Appendix E or Appendix F).
- Verify that the RTD is wired correctly—the heat tracing controllers will always be terminated in the order: source (WHT), sense (WHT), common (RED). When wiring to the 910, the terminals are marked as follows:

Terminal No.	Description
19	Shield
20	TS 1 Source (WHT)
21	TS 1 Sense (WHT)
22	TS 1 Common (RED)
8	Shield
9	TS 2 Source (WHT)
10	TS 2 Sense (WHT)
11	TS 2 Common (RED)

The RTD manufacturer will typically color code the leads with the source and sense being the same color, and the common a different color. Ensure that the RTD extension wire shield is terminated at one end only, normally using the terminal block provided at the terminal board.



IMPORTANT: Some manufacturers use the common Black-White-Red triad color code for the RTD connections. Usually, the RED lead is the common connection (same as the White-White-Red color scheme) and the White and Black connections may be used interchangeably.

2. Seemingly Incorrect Temperature

If you feel that the indicated or displayed temperature is not correct, the controller and the RTD can be quickly checked for correct operation.

To verify the RTD:

TURN THE POWER TO THE CONTROLLER OFF BEFORE PROCEEDING!!

- Disconnect the RTD wiring from the input terminals.
- To calculate the temperature indicated by the RTD, measure the resistance from source (white wire) or sense (white wire) to common (red wire) and subtract the resistance measured between source and sense. This will give a compensated resistance value that can be cross-referenced to one of the RTD tables found in Appendix E or Appendix F.

Compare the measured resistance and cross-referenced temperature value obtained from the RTD table to the indicated or displayed value. These should agree to within the accuracy standards of the HTC and the RTD.



IMPORTANT:

- Ensure you refer to the correct RTD table for the type of RTD you are using.
- Ensure that the TS TYPE setting matches the type of RTD that you are using.

To verify the Controller:

TURN THE POWER TO THE CONTROLLER OFF BEFORE PROCEEDING!!

- Disconnect the RTD wiring from the input terminals.
- Connect a 100 Ω resistor across the source or sense terminal and common. Insert a jumper between the source and sense terminals.
- Apply power to the controller. The indicated or displayed temperature should be about 32°F (0°C) depending on the actual resistance of the test resistor if TS TYPE is set to 100 Ω Platinum.

3. Unstable or Bouncing Temperature

An erratic indication of temperature can be caused by several factors external to the controller, however a bouncing temperature of a few degrees should not be confused with incorrect operation. The controller's accuracy and resolution will result in an indicated temperature change of a couple of degrees if the measured resistance temperature falls between two discrete values (this is sometimes referred to as quantization error).

If the bounce or instability is excessive, check:

- Wire used for extension of the RTD should be three-wire, twisted and shielded with the shield grounded at the controller only. Each of the three lead wires must be of the same gauge.
- The ideal installation has a separate conduit for the RTD leads (if they have been extended). It is not usually a problem to run low signal levels in the same conduit as the power leads even in high power applications, as long as the RTD wire is a twisted, shielded type with an insulation rating equal to or greater than the highest voltage in the conduit.

Follow the proper Electrical Code requirements for your particular installation.

- Terminal connections that are not tight can add resistance to an RTD circuit. Check the tightness of all screw terminal connections at time of installation and during subsequent maintenance checks.
- Check the specifications for the particular cable being used to ensure that it does not have excessive capacitance when used in long lengths. This can cause a temperature offset between what the controller reads and what the RTD actually measures. This again is normally not a problem since the controller compensates for all but the worst cases of this.
- Lastly, it is possible for the RTD itself to fail on an intermittent basis but this failure mode should be considered unusual. This kind of failure is probably the most difficult to find but fortunately it is also the least likely as a failure mechanism.

8.2.2 GROUND FAULT

Ground fault alarms can be due to incorrect installation as well as leakage resulting from wet system components or faulted cables.

The 910 Series Controller detects ground faults by summing the outgoing and return trace currents through an internal current transformer. Under normal operating conditions (no ground fault condition) this current will be zero. When there is a flow of current from one of the trace supply wires to ground, a ground fault condition occurs.

If a ground fault alarm is present on start-up of a new installation it is likely due to a wiring error or damaged cable. To verify this condition:

- Check that the heating circuit neutrals return to the controller and are not connected directly to the distribution panel. This can be a common problem if the installation is a retrofit situation.
- On paralleled circuits, be certain that ALL neutrals return. The late addition of a circuit may not be obvious.

Use the monitoring feature available at the 910 Operator Console or the Model 780/GCC-9000 Group Communications Controller to view the measured ground fault current at the heat trace controller. If this value is at the maximum that the controller can measure, it is usually an indication that the wiring is incorrect. If the value is less than 250 mAmps then an actual ground fault condition may exist in the cable.



IMPORTANT: The controller monitors the integrity of the ground fault (GF) detection transformer and associated wiring. If a fault is detected, the controller will report a GF value of 300 mAmps.

8.3 COMMON ALARMS—WHAT TO LOOK FOR

The 910 has a wide range of alarming features that may be selectively enabled or disabled to allow the monitoring and indication of trouble conditions. Described below are the different alarm conditions available on the 910, their meanings, and possible causes.

8.3.1 High TS 1/ TS 2 Temperature

This alarm appears when the temperature exceeds the HIGH TS ALARM temperature setting.

Cause of Alarm:

- Alarm temperature setting too close to maintain temperature
- Flow of hot product
- Steaming out lines
- Incorrect tracer wiring

8.3.2 LOW TS 1/TS 2 TEMPERATURE

This alarm appears when the temperature decreases below the LOW TS ALARM temperature setting.

Cause of Alarm:

- Alarm temperature setting too close to maintain temperature
- Flow of cold product
- Empty pipe
- Damaged, wet, or missing insulation

-
- Heating cable not sized properly for the application

8.3.3 TS 1/ TS 2 FAILURE

This alarm indicates a sensor is not operating properly. The temperature sensor may fail due to an “open” or “shorted” condition.

Cause of Alarm:

- Incorrect or damaged field wiring—open leads or excess resistance (either intermittent or continuous) may be due to broken or damaged wires or loose terminals.
- Damaged or inoperative temperature sensors

8.3.4 CONTROL TS FAILURE

This alarms a failure of the temperature sensing element designated as the control element by the TS CONTROL MODE setting. Depending on the chosen TS FAIL MODE and TS CONTROL MODE, the output switch may be latched off or on until this failure is corrected.

Cause of Alarm:

- Incorrect or damaged field wiring—open leads or excess resistance (either intermittent or continuous) may be due to broken or damaged wires or loose terminals.
- Damaged or inoperative temperature sensors

8.3.5 HIGH CURRENT

This alarms current levels that are greater than the HIGH CURRENT ALARM setting for the application.

Cause of Alarm:

- Alarm setting too close to normal operating current
- High in-rush current from “cold start” of self regulating cable
- Damaged or partially shorted heating cable
- “As built” cable length is greater than design value

8.3.6 LOW CURRENT

This alarms current levels which are less than the LOW CURRENT ALARM setting.

Cause of Alarm:

- Alarm setting too close to normal operating current
- Low source voltage
- Damaged or inoperative heating cable
- Open connection—wiring problem
- SSR or contactor failed open

8.3.7 HIGH GFI

This alarms ground fault current levels which are greater than the HIGH GFI ALARM setting.

Cause of Alarm:

- Alarm setting too close to normal leakage current
- Damaged cable insulation and/or moisture present
- Moisture in junction box
- Poor splice or termination
- Moisture provides conductive ground path which allows ground fault current

8.3.8 GFI TRIP

This value sets the upper limit of allowable ground fault leakage. Exceeding this limit will result in the output switch being latched off and the alarm activated to indicate a ground fault condition.

Cause of Alarm:

- Trip setting too close to normal leakage current

-
- Damaged cable insulation and/or moisture present
 - Moisture in junction box
 - Poor splice or termination
 - Moisture provides conductive ground path which allows ground fault current

8.3.9 HIGH VOLTAGE

This alarms voltage levels that are greater than the HIGH VOLTAGE ALARM setting.

Cause of Alarm:

- Alarm setting too close to normal operating voltage
- Incorrect wiring
- Power surge

8.3.10 LOW VOLTAGE

This alarms voltage levels which are less than the LOW VOLTAGE ALARM setting.

Cause of Alarm:

- Alarm setting too close to normal operating voltage
- Damaged power cable
- Incorrect VOLTAGE TURNS RATIO
- “Brown-out” conditions
- Loss of power to the circuit

8.3.11 OVERCURRENT TRIP

If the controller is unable to start the cable due to high current or after attempting to soft start it, the controller will trip its output switch off.

Cause of Alarm:

- Excessive in-rush current
- Incorrect wiring
- Damaged cable

8.3.12 SWITCH FAILURE

This alarm indicates that the controller senses current flow when the output switch should be off.

Cause of Alarm:

- Some other device energized heat trace
- Output switch has failed “closed”

8.3.13 HTC RESET

This alarm is latched when power is restored after an interruption. Used to identify intermittent power losses.

Cause of Alarm:

- Circuit breaker tripped
- Power line transient

8.3.14 POWER LIMITING

This alarm indicates that the solid state relay is limiting the average amount of power that is applied to the trace circuit as defined by the MAXIMUM POWER setting.

Cause of Alarm:

- Power applied to trace circuit is being limited to the MAXIMUM POWER setting

8.3.15 C.B. LIMITING

This alarm indicates that the solid state relay is limiting the average current that is applied to the trace circuit to the C.B. CURRENT RATING setting to protect the upstream heater circuit breaker from tripping.

Cause of Alarm:

- Excessive current caused by in-rush current
- C.B. CURRENT RATING setting too low for normal heater current draw or not matched to actual circuit breaker size

8.3.16 SWITCH LIMITING

This alarm indicates that the controller is limiting the average current that is applied to the trace circuit based on the SWITCH RATING setting to protect the solid state relay from excess current.

Cause of Alarm

- Excessive current caused by in-rush current
- Excessive ambient temperature

8.3.17 HIGH RESISTANCE

This alarm indicates that the heating cable resistance has deviated from the NOMINAL RESISTANCE setting by more than the HIGH RESISTANCE ALARM setting.

Cause of Alarm

- Alarm setting too close to actual operating resistance
- NOMINAL RESISTANCE not set properly
- Open connection—wiring problem
- Damaged cable

8.3.18 LOW RESISTANCE

This alarm indicates that the heating cable resistance has deviated from the NOMINAL RESISTANCE setting by more than the LOW RESISTANCE ALARM setting.

Cause of Alarm

- Alarm setting too close to actual operating resistance
- NOMINAL RESISTANCE not set properly
- Partial short—wiring problem
- Damaged cable

8.3.19 EEROM DATA FAILURE

This alarm indicates that the controller has detected a failure in its nonvolatile memory (this is where all of the controller's configuration and calibration settings are stored). This indicates an internal problem and the HTC should be replaced and returned to the factory for repair.

Cause of Alarm:

- The HTC cannot bypass the failed area of its memory and has loaded factory defaults into this failed area.

8.3.20 CONTACTOR COUNT

This alarm indicates that the number of off-to-on transitions of a contactor has exceeded the CONTACTOR COUNT ALARM setting and the contactor should be replaced.

Cause of Alarm

- Contactor has been controlling the trace circuit for a long time
- Some configuration parameter (i.e. DEADBAND, AUTO CYCLE INTERVAL, load shedding etc.) is causing the contactor to toggle more than usual.

SECTION 9—MAINTENANCE

9.1 OPERATOR MAINTENANCE

The 910 series controller is designed to be a maintenance-free product. Once installed properly the only maintenance required is retightening of the terminal connections approximately one week after installation and inspection periodically thereafter. Also, alarm pilot lamps (if installed) may need periodic replacement. EMR versions may require periodic contactor replacement.

 **CAUTION:**

Make sure that the power to the controller is OFF when replacing the pilot lamps! Also, be certain power is OFF to the controller before attempting to test or service the heat tracing. Do not rely on the controller as a disconnect device!

9.2 REPLACEABLE PARTS

There are no user-serviceable parts in the 910 series controller or accessories (except lamps in optional alarm pilot lights). The unit is designed to be modular and easily changed out in the field in a matter of minutes. A 910 appearing inoperative should be returned to the nearest Pentair Industrial Heat Tracing Solutions Service Center for service.

 **WARNING:**

Tampering with the 910 components without approval from Pentair Industrial Heat Tracing Solutions could result in the product's warranty being void.

APPENDIX A—SPECIFICATIONS

Specifications are @ 25°C unless otherwise noted and are subject to change without notice.

System Ratings

Storage Ambient	-40°F to 185°F [-40°C to 85°C] Approvals CSA C/US
Classification	<ul style="list-style-type: none">• Cl I, Div 2, Grps A,B,C,D and Ex nA IIA, IIB, IIC (Zone 2)• SSR Version T-code: T4• Ordinary locations (SSR and EMR versions)

Wiring Terminal Ratings

Signal Terminals	28-12 AWG, strip length: 0.2"
Power Terminals	30A: 22-8 AWG, strip length: 0.47", torque: 10.7 in-lb (1.2 N-m)
Ground Lugs	14-6 AWG torque: 12 in-lb (1.35 N-m)

Assembly Ratings

Operating Temperature	-40°F to 140°F [-40°C to 60°C] Enclosures FRP: Nema 4X/IP65 SS: Type 304, Nema 4X/IP65
Solid State Relay Rating	<ul style="list-style-type: none">• 2 pole switching• 30 A continuous @ 40°C, derate linearly to: 15 A max. @ 60°C resistive load• 100-277 Vac nom. max., 80 A 1 sec. in-rush, 625 A 1 cycle in-rush
Electromechanical Relay Rating	<ul style="list-style-type: none">• 2 pole switching• 30 A continuous @ 40°C derate linearly to: 20 A max. @ 60°C• 100-277 Vac nom. max.

Control Module Ratings

Operating Temperature	-40°F to 140°F [-40°C to 60°C]
Power Requirements	100 to 277 Vac nom., 1PH, 50/60 Hz, 0.2A. max. + 0.75A (Aux. AC output terminals)
Output Power	+12Vdc nom., 250ma. max.
Control Modes	<ul style="list-style-type: none">• Proportional, Deadband, Proportional Ambient (SSR), Proportional Ambient (Contactor) modes• Adjustable 2°F to 90°F (1°C to 50°C)
Temperature Inputs	(2) RTD inputs: 3-wire 100Ω Platinum (DIN 43760, $\alpha=0.00385\Omega/\Omega/^\circ\text{C}$) or 2/3-wire 100Ω Ni-Fe, open/shorted sensor detection/protection, lead resistance compensated 0 to 20Ω per lead
Temperature Measurement Range	-76°F to 1058°F [-60°C to 570°C], accuracy $\pm 0.5\%$ of span $\pm 1\text{LSD}$
Voltage Measurement Range	80 to 295Vac, accuracy: $\pm 1\%$ of span $\pm 2\text{LSD}$, repeatability: $\pm 1.5\%$ of span
Current Measurement Range	0.3 to 100A, resolution: 0.1A (0.3A to 11A range), 0.3A (11A to 40A range), 0.7A (40A to 100A range), accuracy: $\pm 2.5\%$ of reading \pm resolution
GF Current Measurement Range	20 to 250ma, accuracy: $\pm 2.5\%$ of span $\pm 2\text{LSD}$ at nominal load, repeatability: $\pm 4\%$ of span
Dry Contact Alarm Relay Output	48Vac/dc, 500ma, 10VA switching max.
AC Alarm Relay Output	0.75A, 100-277 Vac nom. max.

APPENDIX B—TYPICAL ENCLOSURE DIMENSIONS

The following drawings provide the user with enclosure size and mounting dimensions for the stock 910 enclosure assemblies. Please contact your local Pentair Industrial Heat Tracing Solutions representative for information regarding other available sizes and configurations.

B.1 STANDARD FIBERGLASS EMR ASSEMBLY #10170-001

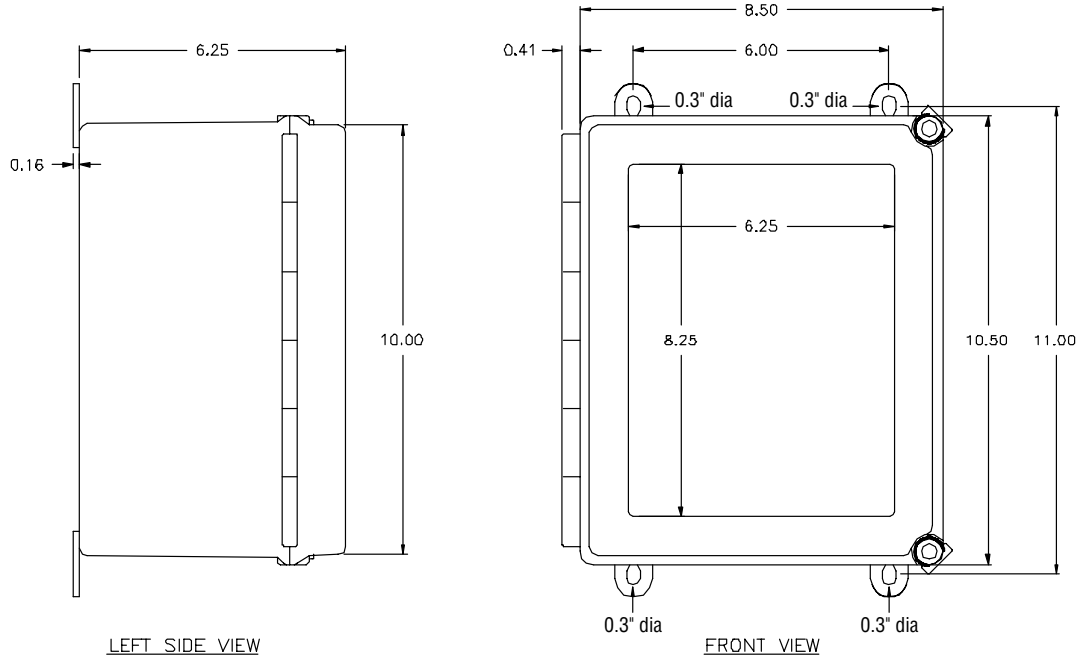

2-pole 30A EMR Assembly
in a Fiberglass
Enclosure with Window.

Model: 910*E1FWL*EMR2

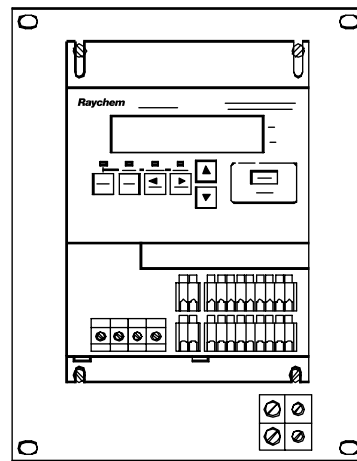

BACKPLANE

B.2 OPTIONAL STAINLESS STEEL EMR ASSEMBLY #10170-003

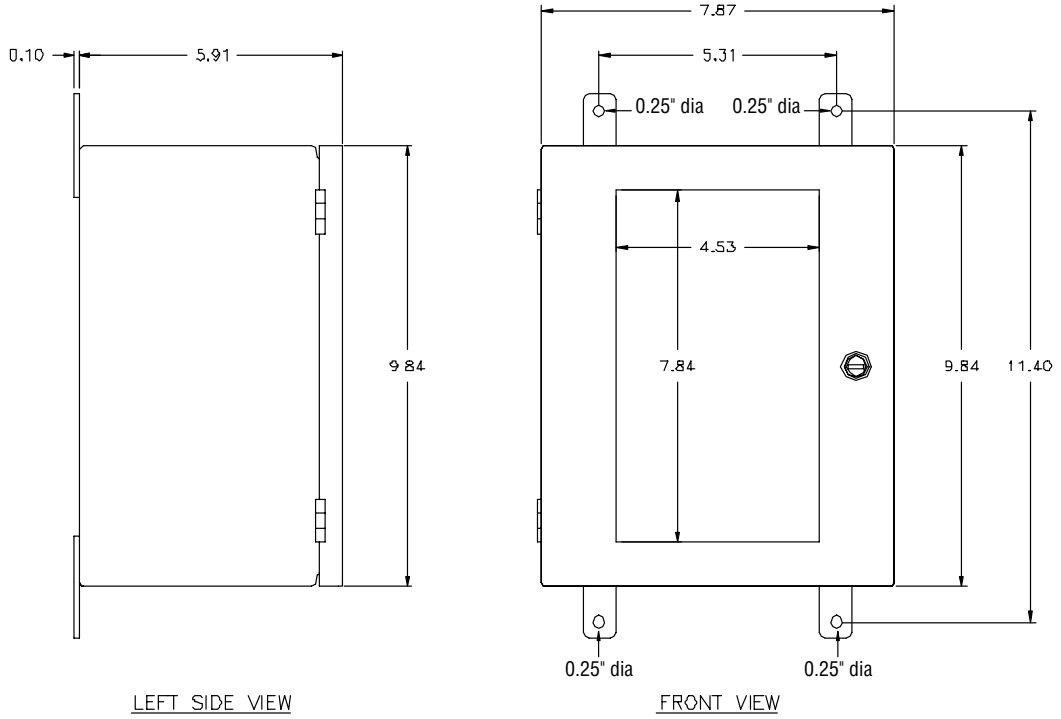

2-pole 30A EMR Assembly
in a Fiberglass
Enclosure with Window.
Model: 910*E1FWL*EMR2

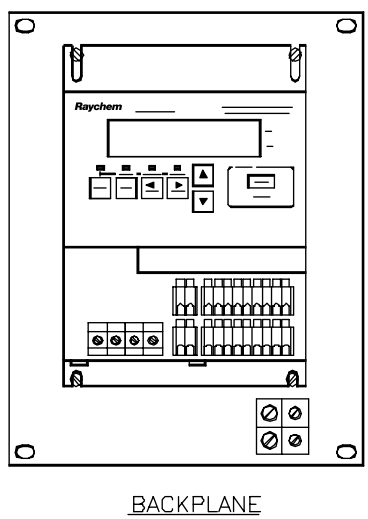

B.3 STANDARD FIBERGLASS SSR ASSEMBLY #10170-0002

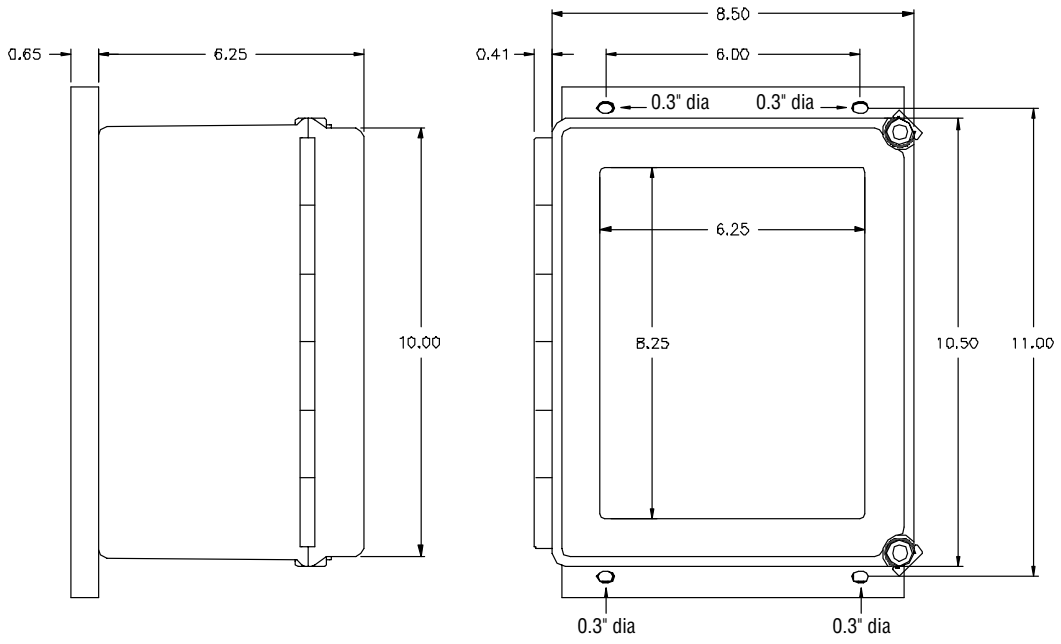

LEFT SIDE VIEW

FRONT VIEW

2-pole 30A EMR Assembly
in a Fiberglass
Enclosure with Window.

Model: 910*E1FWL*EMR2

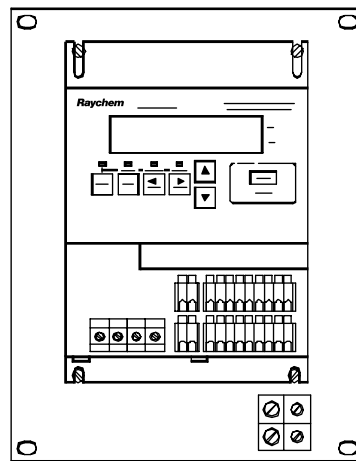

BACKPLANE

B.4 OPTIONAL STAINLESS STEEL SSR ASSEMBLY #10170-004

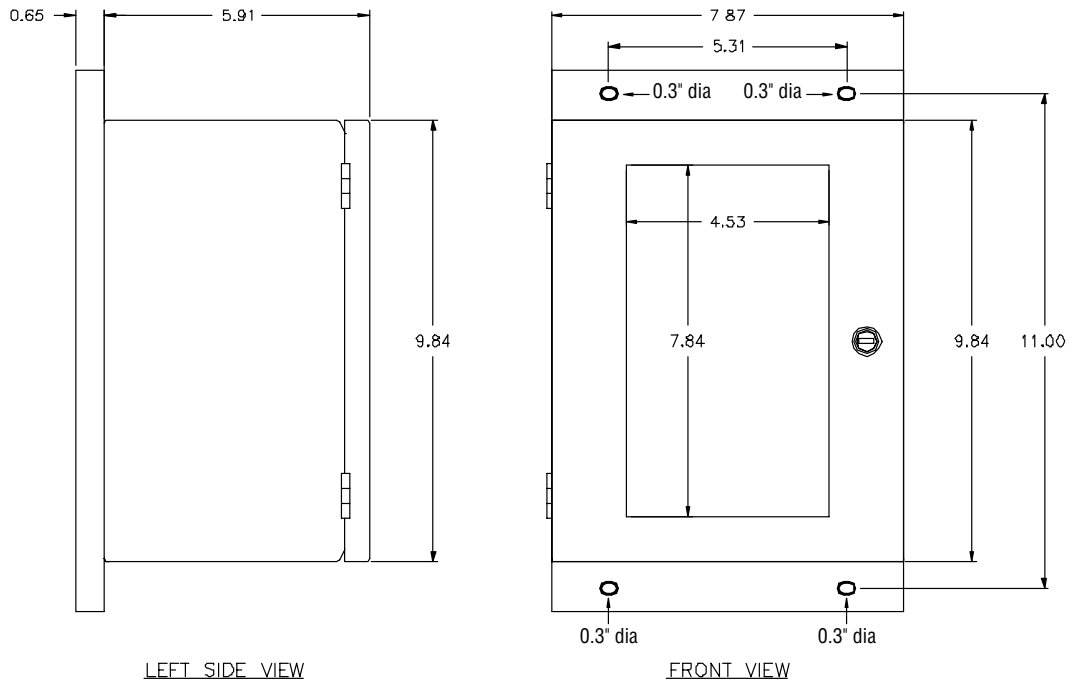

2-pole 30A EMR Assembly
in a Fiberglass
Enclosure with Window.
Model: 910*E1FWL*EMR2

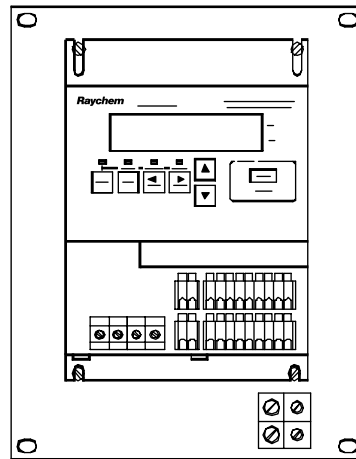

BACKPLANE

B.5 910 SERIES HTC CONTROL MODULE DIMENSIONS

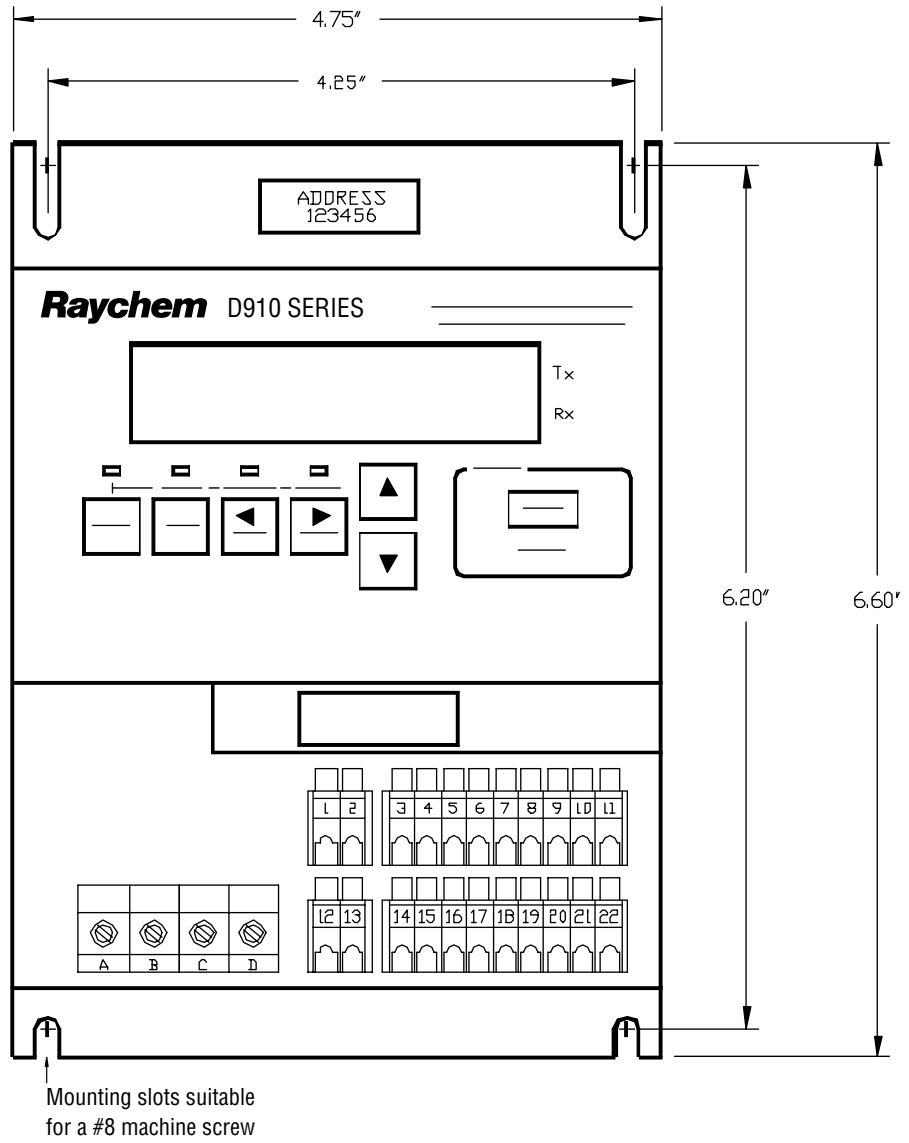

APPENDIX C—WIRING DIAGRAMS

The following drawings provide sample wiring diagrams for the 910 Series control products and optional accessories. Please contact your local Pentair Industrial Heat Tracing Solutions representative for information regarding other available options.

C.1 TS WIRING

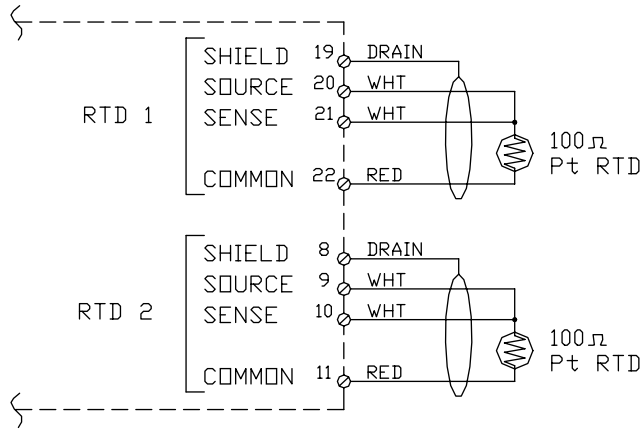

Note: Temperature sensor manufacturers may use different lead wire colors than those shown in the diagram above. Some common color combinations are shown in the table below, but others may also be available. See Sections 2.7.1 and 8.2.1 for additional details.

Signal Description	Lead Wire Color Scheme #1	Lead Wire Color Scheme #2	Lead Wire Color Scheme #3 (IEC 751)
Source	White	White	Red
Sense	White	Black	Red
Common	Red	Red	White

C.2 POWER WIRING

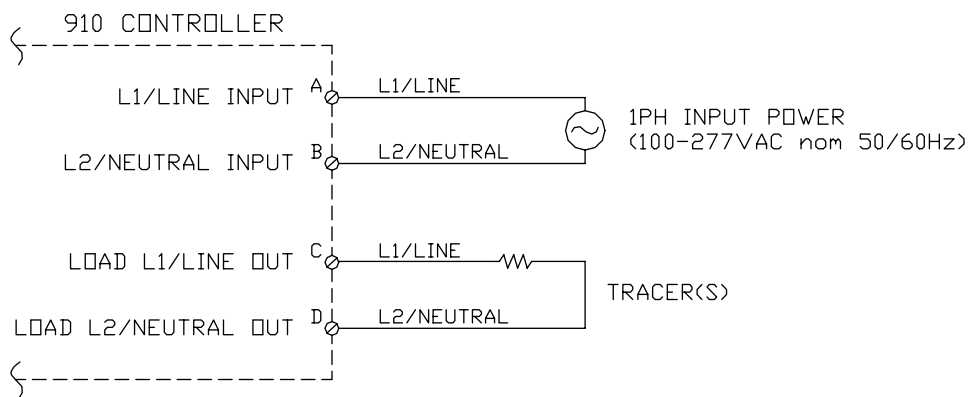

C.3.1 2-WIRE MODEM OPTION

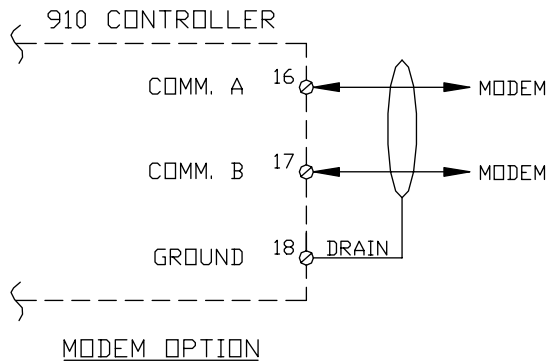

C.3.2 2-WIRE RS-485 OPTION

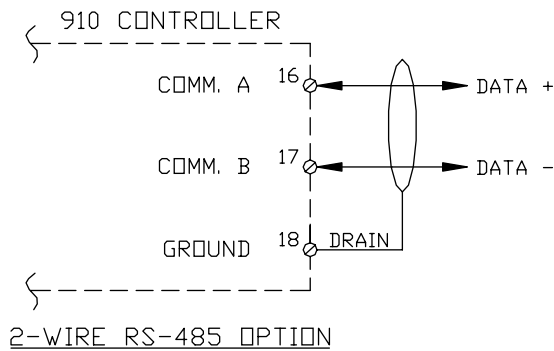

C.3.3 RS-232 OPTION

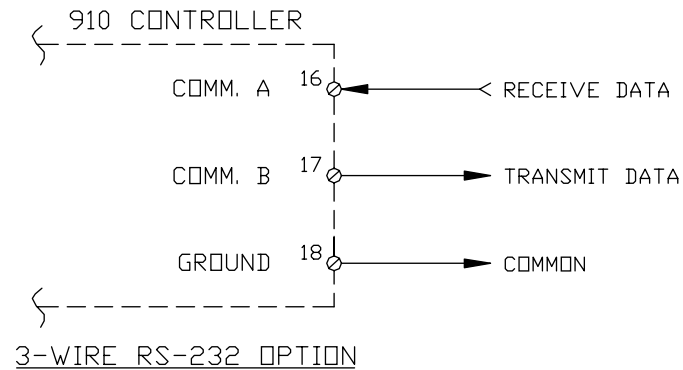

C.4 ALARM OUTPUT WIRING

C.4.1 USED AS A DRY CONTACT

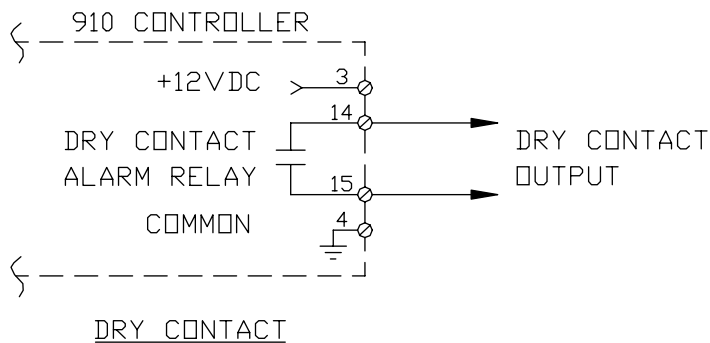

C.4.2 USED AS A SWITCHED DC CONTACT

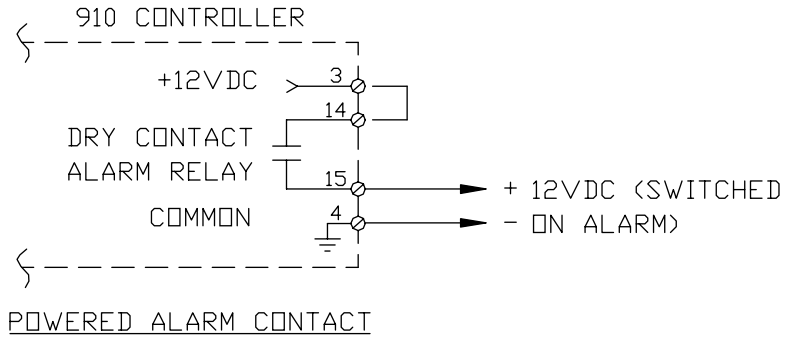

C.4.3 USED AS AN AC ALARM RELAY

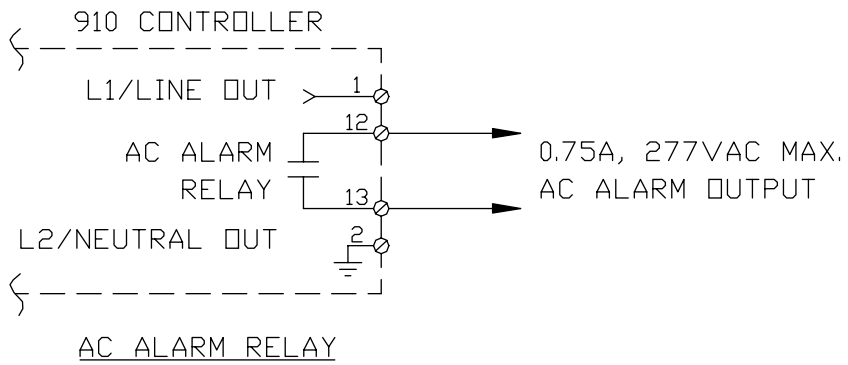

C.4.4 Used as a Powered AC Alarm Relay

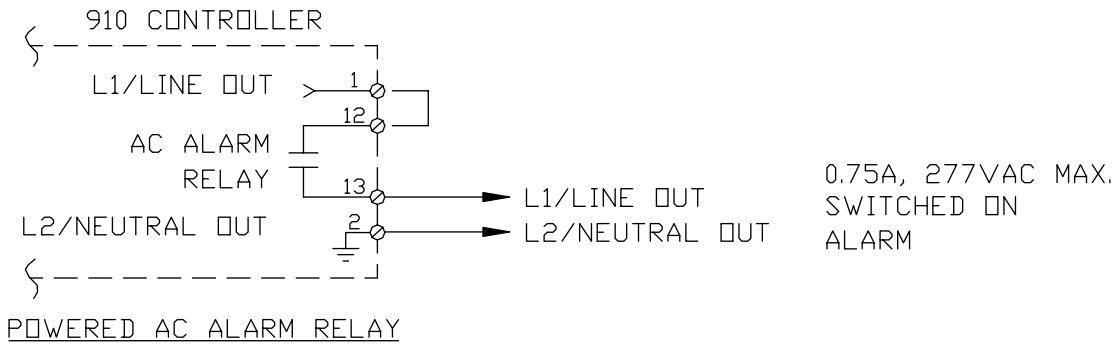

C.5 EXTERNAL INPUT/OUTPUT PORT WIRING

C.5.1 EXTERNAL INHIBIT/OVERRIDE USING A DRY CONTACT

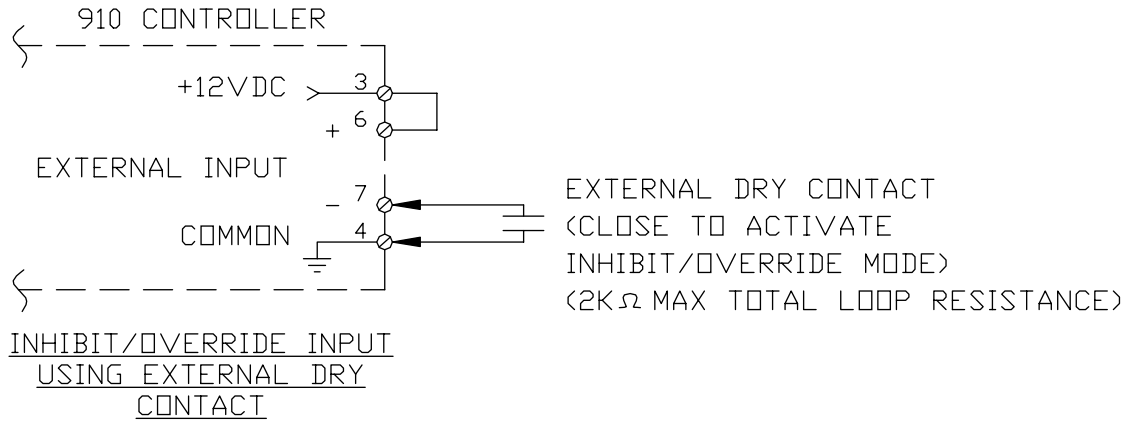

D910-009

C.5.2 EXTERNAL INHIBIT/OVERRIDE USING A DC SIGNAL

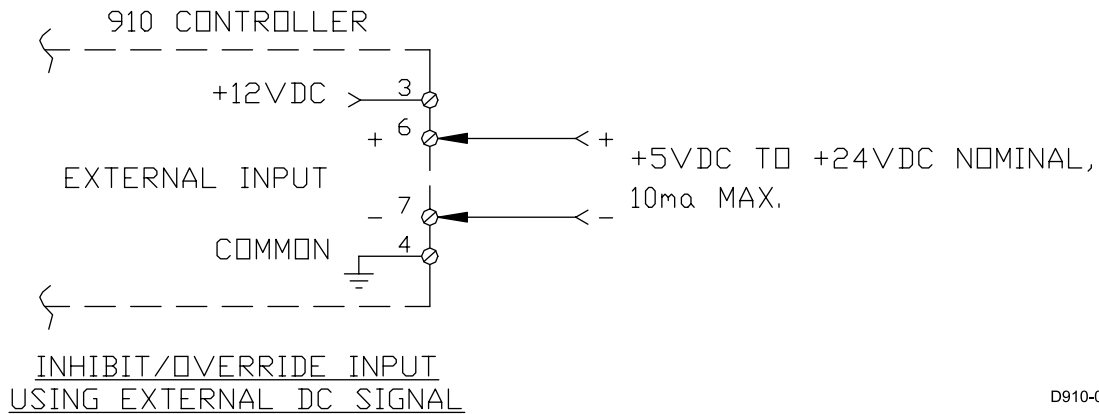

D910-009

APPENDIX D—HTC LOAD SHEDDING SEQUENCE

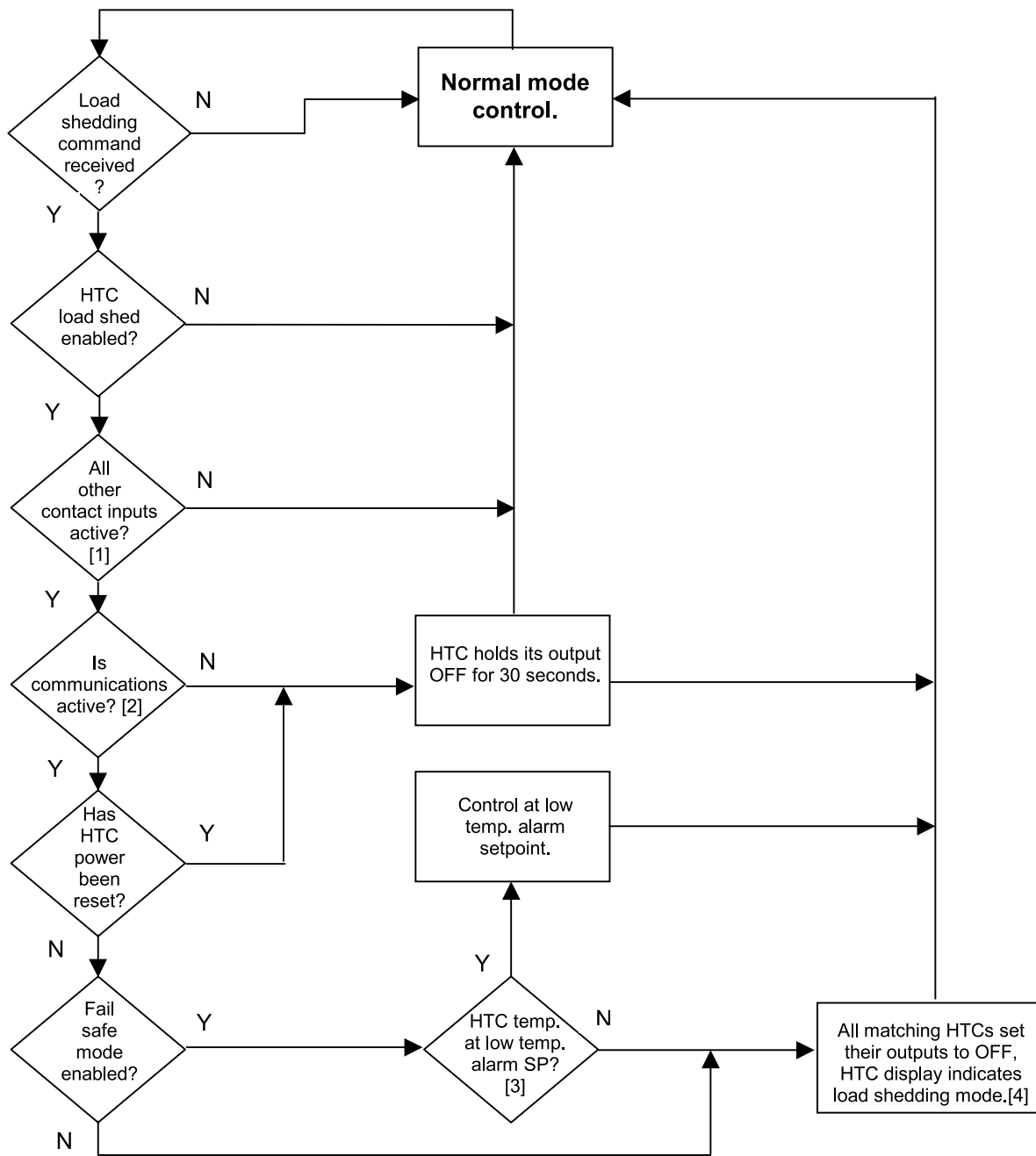

APPENDIX E—100 Ω PLATINUM RTD TABLE

DIN 43760—100 Ω PLATINUM RESISTANCE TEMPERATURE (RTD)—0.00385 OHMS/OHM/°C

Ohms	°C	°F	Ohms	°C	°F	Ohms	°C	°F
60.25	-100	-148	159.18	155	311	250.48	410	770
62.28	-95	-139	161.04	160	320	252.19	415	779
64.30	-90	-130	162.90	165	329	253.90	420	788
66.31	-85	-121	164.76	170	338	255.61	425	797
68.33	-80	-112	166.61	175	347	257.32	430	806
70.33	-75	-103	168.46	180	356	259.02	435	815
72.33	-70	-94	170.31	185	365	260.72	440	824
74.33	-65	-85	172.16	190	374	262.42	445	833
76.33	-60	-76	174.00	195	383	264.11	450	842
78.32	-55	-67	175.84	200	392	265.80	455	851
80.31	-50	-58	177.68	205	401	267.49	460	860
82.33	-45	-49	179.51	210	410	269.18	465	869
84.27	-40	-40	181.34	215	419	270.86	470	878
86.25	-35	-31	183.17	220	428	272.54	475	887
88.22	-30	-22	184.99	225	437	274.22	480	896
90.19	-25	-13	186.82	230	445	275.89	485	905
92.16	-20	-4	188.63	235	455	277.56	490	914
94.12	-15	5	190.45	240	464	279.23	495	923
96.09	-10	14	192.26	245	473	280.90	500	932
98.04	-5	23	194.07	250	482	282.56	505	941
100.0	0	32	195.88	255	491	284.22	510	950
101.95	5	41	197.69	260	500	285.87	515	959
103.90	10	50	199.49	265	509	287.53	520	968
105.85	15	59	201.29	270	518	289.18	525	977
107.79	20	68	203.08	275	527	290.83	530	986
109.73	25	77	204.88	280	536	292.47	535	995
111.67	30	86	206.67	285	545	294.11	540	1004
113.61	35	95	208.45	290	554	295.75	545	1013
115.54	40	104	210.24	295	563	297.39	550	1022
117.47	45	113	212.02	300	572	299.02	555	1031
119.40	50	122	213.80	305	581	300.65	560	1040
121.32	55	131	215.57	310	590	302.28	565	1049
123.24	60	140	217.35	315	599	303.91	570	1058
125.16	65	149	219.12	320	608	305.53	575	1067
127.07	70	158	220.88	325	617	307.15	580	1076
128.98	75	167	222.65	330	626	308.76	585	1085
130.89	80	176	224.41	335	635	310.38	590	1094
132.80	85	185	226.17	340	644	311.99	595	1103
134.70	90	194	227.92	345	653	313.59	600	1112
136.60	95	203	229.67	350	662	315.20	605	1121
138.50	100	212	231.42	355	671	316.80	610	1130
140.39	105	221	233.17	360	680	318.4	615	1139
142.29	110	230	234.91	365	689	319.99	620	1148
144.17	115	239	236.65	370	698	321.59	625	1157
146.06	120	248	238.39	375	707	323.18	630	1166
147.94	125	257	240.13	380	716	324.76	635	1175
149.82	130	266	241.86	385	725	326.35	640	1184
151.70	135	275	243.59	390	734	327.93	645	1193
153.58	140	284	245.31	395	743	329.51	650	1202
155.45	145	293	247.04	400	752	331.08	655	1211
157.31	150	302	248.76	405	761	332.66	660	1220

APPENDIX F—100 Ω NICKEL-IRON RTD TABLE

Ohms	°C	°F	Ohms	°C	°F	Ohms	°C	°F
69.8	-73	-100	133.4	68	155	218.2	210	410
71.1	-70	095	134.8	71	160	220.1	212	415
72.3	-67	-90	136.3	73	165	222.0	215	420
73.1	-65	-85	137.8	76	170	223.9	218	425
74.3	-62	-80	139.3	79	175	225.8	221	430
75.5	-59	-75	140.8	82	180	227.7	223	435
76.7	-56	-70	142.3	85	185	229.6	226	440
78.0	-53	-65	143.8	87	190	231.5	229	445
78.8	-51	-60	145.3	90	195	233.5	232	450
80.0	-48	-55	146.8	93	200	235.4	235	455
81.2	-45	-50	148.4	96	205	237.4	237	460
82.2	-42	-45	149.9	98	210	239.3	240	465
82.9	-40	-40	151.5	101	215	241.3	243	470
84.2	-37	-35	153.0	104	220	243.3	246	475
85.7	-34	-30	154.6	107	225	245.3	248	480
86.9	-31	-25	156.2	110	230	247.2	251	485
88.1	-28	-20	157.7	112	235	249.3	254	490
88.9	-26	-15	159.3	115	240	251.2	257	495
90.1	-23	-10	160.9	118	245	253.3	260	500
91.4	-20	-5	162.5	121	250	255.2	262	505
92.2	-17	0	164.2	123	255	257.3	265	510
93.4	-15	5	165.8	126	260	259.3	268	515
94.6	-12	10	167.4	129	265	261.4	271	520
95.8	-9	15	169.0	132	270	263.4	273	525
97.1	-6	20	170.7	135	275	265.5	276	530
98.3	-3	25	172.3	137	280	267.6	279	535
99.5	-1	30	174.0	140	285	269.6	282	540
100.8	1	35	175.7	143	290	271.7	285	545
102.0	4	40	177.4	146	295	273.8	287	550
103.3	7	45	179.1	148	300	275.9	290	555
104.6	10	50	180.8	151	305	278.0	293	560
105.9	12	55	182.5	154	310	280.1	296	565
107.2	15	60	184.2	157	315	282.3	298	570
108.5	18	65	185.9	160	320	284.4	301	575
109.8	21	70	187.6	162	325	286.5	304	580
111.1	23	75	189.	165	330	288.6	307	585
112.5	26	80	191.1	168	335	290.8	310	590
113.8	29	85	192.9	171	340	293.1	312	595
115.2	32	90	194.5	173	345	295.2	315	600
116.5	35	95	196.4	176	350	297.5	318	605
117.9	37	100	198.2	179	355	299.8	321	610
119.2	40	105	199.9	182	360	301.4	323	615
120.6	43	110	201.7	185	365	303.7	326	620
122.0	46	115	203.5	187	370	306.0	329	625
123.4	48	120	205.3	190	375	308.3	332	630
124.8	51	125	207.2	193	380	310.6	335	635
126.2	54	130	109.0	196	385	312.2	337	640
127.6	57	135	210.8	198	390	314.5	340	645
129.0	60	140	212.7	201	395	316.8	343	650
130.5	62	145	214.5	204	400	319.1	346	655
131.9	65	150	216.4	207	405	320.6	348	660

910 SERIES HTC

BASIC MODE MENU

(All other parameters are set as shown in the Advanced Mode Sub-Menus)

Configuration Mode Menu

Parameter	Factory	User
Control Setpoint	68°F (20°C)	
Lo TS 1	14°F (-10°C)	
Lo Load	1.0A	
Switch Control Mode	Deadband	
Circuit Breaker	*n/a (30.0A)	
Temperature Units	°F	
Feature Mode	Basic	

ADVANCED MODE MENUS

Configuration Mode Main Menu

Parameter	Factory	User
Control Setpoint	68°F (20°C)	
Lo TS 1	14°F (-10°C)	
Lo Load	1.0 A	
Hi GFI	20 mA	
GFI Trip	30 mA	
Feature Mode	Advanced	

TS Alarms Configuration Sub-Menu

Parameter	Factory	User
TS 1 Fail	Enable	
Lo TS 1	Enable	
Lo TS 1	14°F (-10°C)	
Hi TS 1	Disable	
Hi TS 1	*n/a (212°F (100°C))	
TS 2 Fail	Disable	
Lo TS 2	Disable	
Lo TS 2	*n/a (14°F (-10°C))	
Hi TS 2	Disable	
Hi TS 2	*n/a (212°F (100°C))	
Lo TS Filter	0 min	
Hi TS Filter	*n/a (0 min)	
Latch TS Alarms	Yes	
CTL TS Fail	Enable	

Other Alarms Configuration Sub-Menu

Parameter	Factory	User
Lo Load	Enable Lo Load	1.0 A Lo Load Filter 0 sec
Hi Load	Disable	
Hi Load	*n/a (30.0A)	
Hi Load Filter	*n/a (0 sec)	
Hi GFI	Enable	
Hi GFI	20 mA	
Hi GFI Filter	0 sec	
GFI Trip	Enable	
GFI Trip	30 mA	
Lo Volt	Enable	
Lo Volt	90 V	
Lo Volt Filter	0 sec	
Hi Volt	Disable	
Hi Volt	*n/a (270V)	
Hi Volt Filter	*n/a (0 sec)	
Lo Resist	Disable	
Lo Resist	*n/a (50%)	
Lo Resist Filter	*n/a (0 sec)	
Hi Resist	Disable	
Hi Resist	*n/a (50%)	
Hi Resist Filter	*n/a (0 sec)	
Nominal Resist	*n/a (6.00 Ω)	
Overcurrent Trip	*n/a (Enable)	
Switch Fail	Enable	
HTC Reset	Disable	
C.B. Limiting	*n/a (Disable)	
Power Limiting	*n/a (Disable)	
Switch Limiting	*n/a (Disable)	
Contacto Count	Enable	
Contacto Count	200,000	
EEROM Data Fail	Enable	

Point Setup Sub-Menu

Parameter	Factory	User
Tag	TAG -(factory ID)	
Switch Control Mode	Deadband	
Prop Band	*n/a (4°F [2°C])	
Deadband	5°F (3°C)	
Cycle Time	*n/a (10 min)	
Switch Rating	*n/a (30.0 A)	
Circuit Breaker	*n/a (30.0 A)	
Max Power	*n/a (7200 W)	
TS Fail Mode	Off	
TS CTL Mode	TS1-Fail Off	
TS 1 Type	100Ω Plat	
TS 1 Lead Resist	*n/a (0)Ω	
TS 1 Hi Limit	Disable	
TS 2 Type	100Ω Plat	
TS 2 Lead Resist	*n/a (0Ω)	
TS 2 Hi Limit	Disable	
Autocycle	Enable	
Autocycle Interval	8	
Autocycle Units	Hours	
Override Source	Remote	
Load Shedding	Disable	

Miscellaneous Setup Sub-Menu

Parameter	Factory	User
Temperature Units	°F	
Version	V3.1x.xx	n/a
Ext. Input	Not used	
Flash Alarm Output	Yes	
Alarm Output	N.C.	
Language	English	
Passcode	0	
Scroll Delay	0.15 sec	
Load Defaults	(See user manual)	

Communications Setup Sub-Menu

Parameter	Factory	User
Protocol	HTCBUS	
HTCBUS Addr	(factory ID)	
Modbus Addr	*n/a (1)	
Modbus Sub Addr	*n/a (0)	
Baud Rate	Auto	
Parity	*n/a (None)	
Hardware	None, modem, RS-232, RS-485n/a	
Driver	Auto	
Profile	Auto	
Tx Delay	0.06 sec	

*n/a: Parameter may only appear if certain features are enabled. Values shown in brackets are the Factory defaults if the settings are enabled. This information defines the default 910 Series Control Module configuration as set by the Factory for firmware V3.1X. These settings are subject to change without notice. It is the user's responsibility to verify that all configuration parameters are chosen appropriately for the intended application.



WWW.PENTAIRTHERMAL.COM

NORTH AMERICA

Tel: +1.800.545.6258
Fax: +1.800.527.5703
Tel: +1.650.216.1526
Fax: +1.650.474.7711
thermal.info@pentair.com

EUROPE, MIDDLE EAST, AFRICA

Tel: +32.16.213.511
Fax: +32.16.213.603
thermal.info@pentair.com

ASIA PACIFIC

Tel: +86.21.2412.1688
Fax: +86.21.5426.2937
cn.thermal.info@pentair.com

LATIN AMERICA

Tel: +1.713.868.4800
Fax: +1.713.868.2333
thermal.info@pentair.com

Pentair is owned by Pentair or its global affiliates. All other trademarks are the property of their respective owners. Pentair reserves the right to change specifications without prior notice.

© 2001-2015 Pentair.