

---

*I-7547*

*Ethernet To HART Converter*

User's Manual

Warranty

All products manufactured by ICP DAS are under warranty regarding defective materials for a period of one year from the date of delivery to the original purchaser.

Warning

ICP DAS assumes no liability for damages resulting from the use of this product. ICP DAS reserves the right to change this manual at any time without notice. The information furnished by ICP DAS is believed to be accurate and reliable. However, no responsibility is assumed by ICP DAS for its use, or for any infringements of patents or other rights of third parties resulting from its use.

Copyright

Copyright 2013 by ICP DAS. All rights are reserved.

Trademark

The names used for identification only may be registered trademarks of their respective companies.

---

## Table of Contents

<b>1. Introduction</b>	<b>4</b>
1.1 Features	4
1.2 Specifications	5
<b>2. Hardware</b>	<b>7</b>
2.1 Pin Assignment of I-7547	8
2.1.1 Pin Function Description	8
2.1.2 HART Wiring	9
2.2 Terminator Resistor Settings	11
2.3 Init / Normal Dip-switch	12
2.3.1 Firmware Update Mode	12
2.3.2 Firmware Operation Mode	14
2.4 LED Indication	14
2.4.1 LED Function	15
2.4.2 LED Indication Table	15
2.5 Cable Selection	15
<b>3. Web Server Configuration</b>	<b>17</b>
3.1 Connect to I-7547 Web Server	17
3.2 Home	18
3.3 Network Setting	18
3.4 Monitor	21
3.5 Change Password	22
3.6 Logout	22
<b>4. HC_Tool Utility</b>	<b>23</b>
4.1 VxComm Utility	23
4.2 Run HC_Tool	25
4.3 Serial Port and HART Command Settings	26
4.3.1 Serial port settings	26
4.3.2 HART Frame Settings	27
4.4 Search HART devices	27
4.4.1 Search HART devices automatically	27
4.4.2 Search HART devices by manual	28
4.4.3 Search HART devices	29
4.5 Send / Receive HART Frame (SRMsg)	31
4.6 HART Information Log (Data Log)	32
4.7 HART Configuration (HTCfg)	33
4.8 Module Configuration (ModCfg)	35

---

<b>5. History Version.....</b>	<b>38</b>
--------------------------------	-----------

---

# 1. Introduction

I-7547 is an Ethernet to HART converter designed as the master device of HART protocol. It allows users to access the HART slave via Ethernet by using virtual COM port. These HART slave devices may be a transmitter, actuator, current output device and so forth. I-7547 provides four HART channels and built-in 250  $\Omega$  load resistor in each HART channel adjustable by jumper. In addition, we also provide free utility tool (HC\_Tool) for users to configure I-7547 and test HART communication easily and quickly.

The following is the application structure of I-7547.

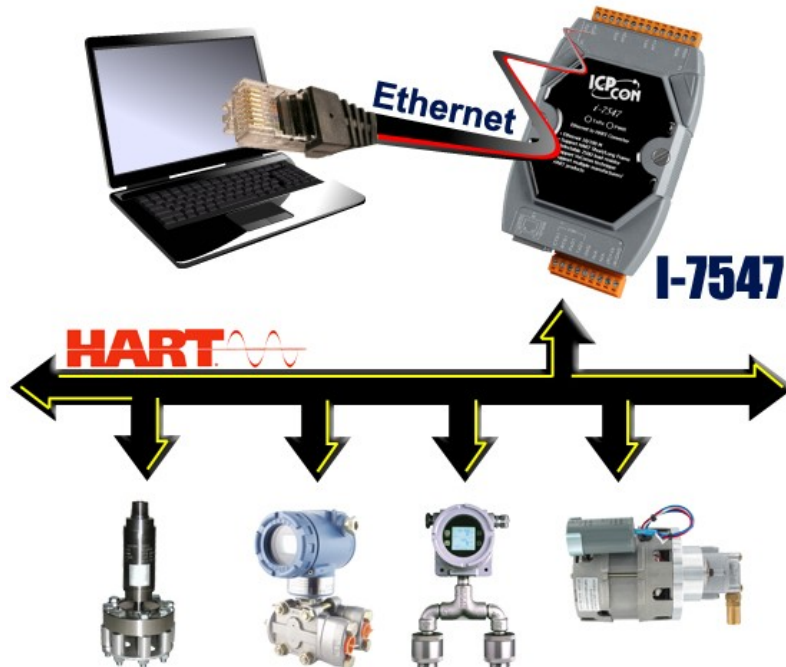

## 1.1 Features

- Support HART Short / Long frame.
- Support HART Burst mode.
- Support point-to-point or multi-drop HART mode.
- Support connecting up to 15 HART slave devices.
- Allow two HART masters.
- Provide utility tool for module configuration and HART communication.

- Provide four HART channels.
- Support firmware update via Ethernet
- Provide PWR / TxRx indication LED
- 4KV ESD Protection
- Built-in Watchdog
- Selectable 250Ω load resistor for each HART channel.

## 1.2 Specifications

### [ Ethernet Spec. ]

Ethernet Port	10/100 Base-TX with Auto MDI/MDI-X
Virtual COM	Created by VxComm Utility
Built-In Web Server	Ethernet Parameters Configuration

### [ HART Spec. ]

Channel	4
Connector	2-pin screwed terminal block (for each HART Ch.)
Device type	Two-wiring or four-wiring HART devices
Network	Point to Point or Multi-drop
Comm. Mode	Only HART digital communication
Frame	Short or Long frame
Burst Mode	Support
Max. Device	15 HART slave devices
Load Resistor	Selectable 250Ω by Jumper (for each HART Ch.)
Isolation	500 VDC
Operate Mode	HART Master and supports all HART commands

### [ COM Spec. ]

COM1	Tx / Rx / GND / RTS / CTS
Baud Rate (bps)	1200 ~ 115200bps
Data Format	N/O/E (parity), 5/6/7/8 (data bit), 1/2 (stop bit)

### [ Power Requirement ]

Power supply	Unregulated +10 ~ +30 VDC
--------------	---------------------------

Protection	Power reverse protection, Over-Voltage brown-out protection
Power Consumption	1.5W

**[ Module spec. ]**

Dimensions	123mm x 72mm x 35mm (H x W x D)
Operating temperature	-25 ~ +75 °C (-13 to 167 °F)
Storage temperature	-30 ~ +80 °C (-22 to 176 °F)
Humidity	5% ~ 95% RH, non-condensing
LED	PWR : Power Indicator TxRx : Data Received from Ethernet / HART Indicator

**[ Utility Tool ]**

- Provide module configuration and HART communication easily and quickly.
- Provide HART devices search automatically.
- Provide diagnostic Information of HART device.
- Provide data logging for HART communication.

**[ Application ]**

- Current Measuring.
- Petrochemical Industry Application.
- Environment Monitoring.
- Tunnel Monitoring.
- Monitor system.
- Building Monitoring.

## 2. Hardware

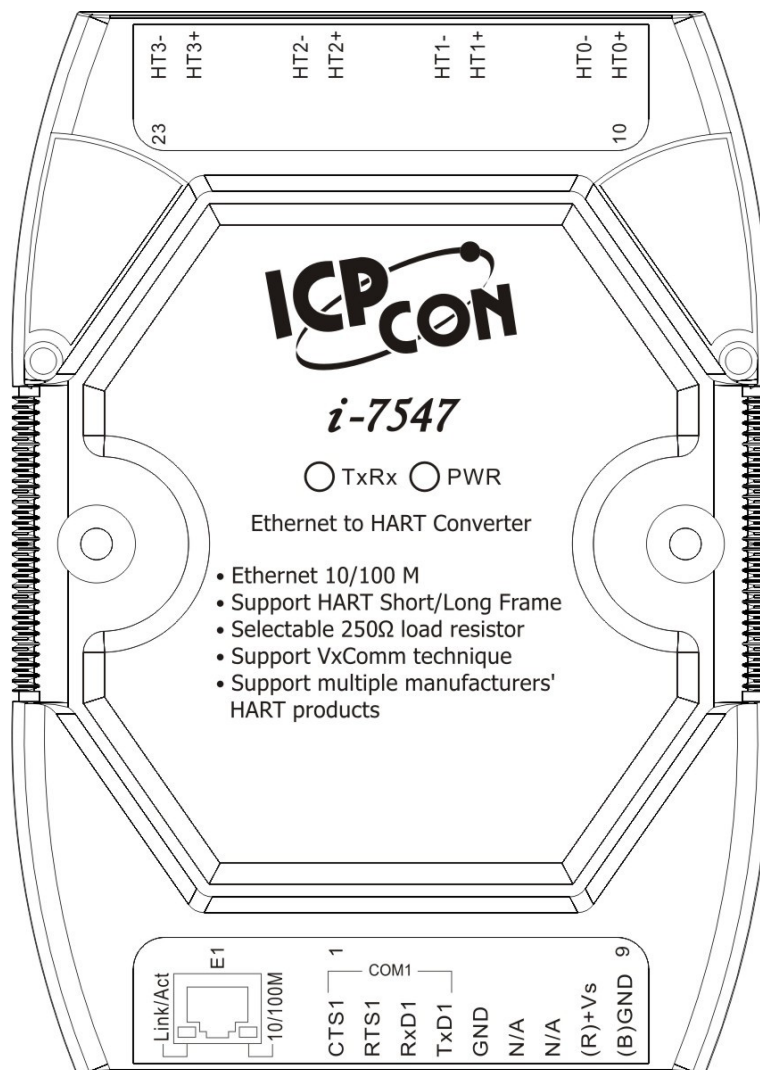

Figure 2-1: Hardware externals of I-7547

## 2.1 Pin Assignment of I-7547

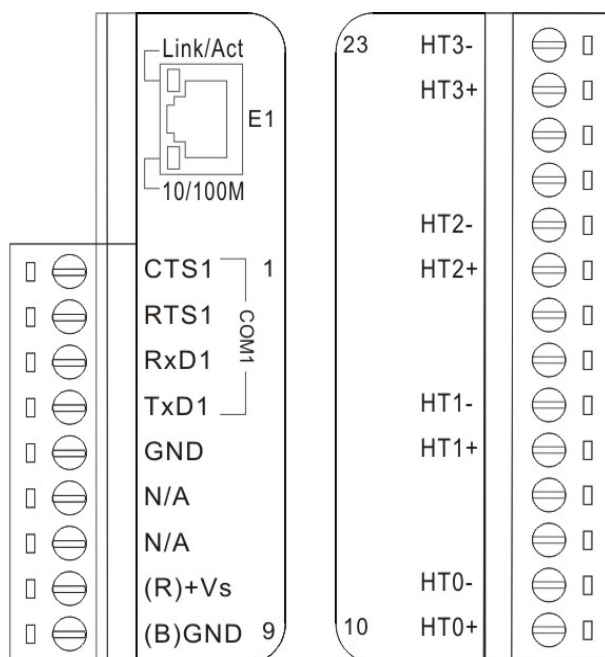

Figure 2-3: Pin Assignment of I-7547

### 2.1.1 Pin Function Description

Pin No.	Pin Name	Pin Function Description
1	CTS1	CTS of RS-232
2	RTS1	RTS of RS-232
3	RxD1	Receive Data of RS-232
4	TxD1	Transmit Data of RS-232
5	GND	GND of RS-232
6	-	N/A
7	-	N/A
8	+Vs	V+ of Power Supply (+10V~+30Vdc)
9	GND	GND of Power Supply
10	HT0+	HART+ of port 0
11	HT0-	HART- of port 0
12	-	N/A
13	-	N/A
14	HT1+	HART+ of port 1
15	HT1-	HART- of port 1
16	-	N/A



17	-	N/A
18	HT2+	HART+ of port 2
19	HT2-	HART- of port 2
20	-	N/A
21	-	N/A
22	HT3+	HART+ of port 3
23	HT3-	HART- of port 3
E1	Ethernet	10 / 100M

### 2.1.2 HART Wiring

The HART network connection can be divided to the following two types.

- (1) "Loop Power Source" Mode.
- (2) "External Power Source" Mode.

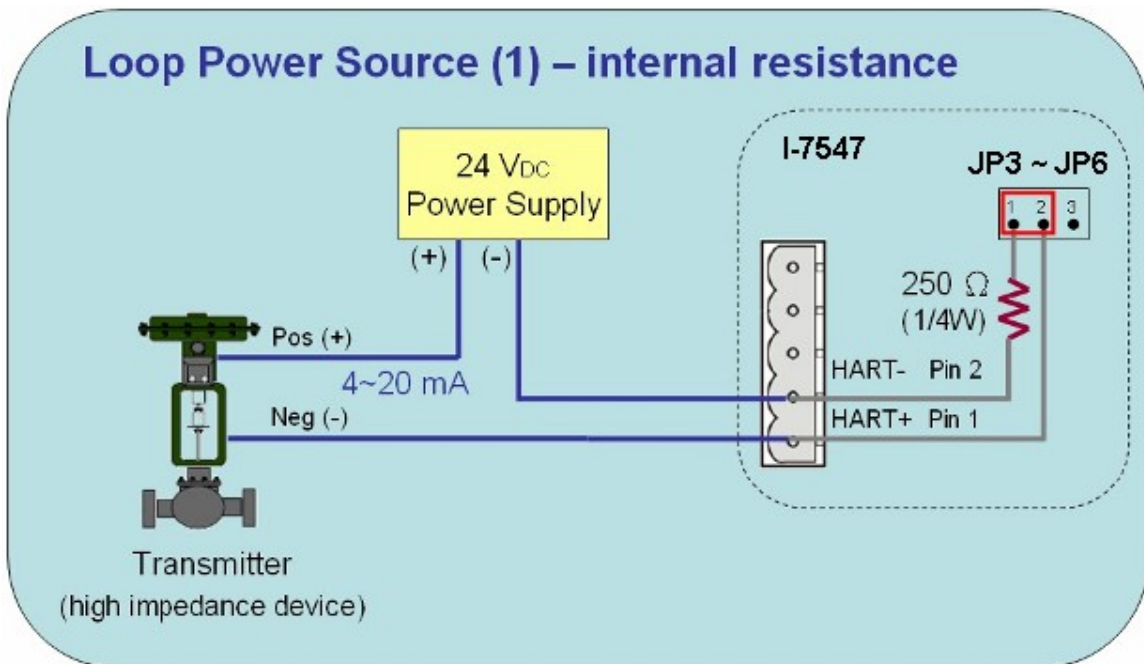

Ex1 : Loop Power Source (Internal Resistance)

## Loop Power Source (2) – external resistance

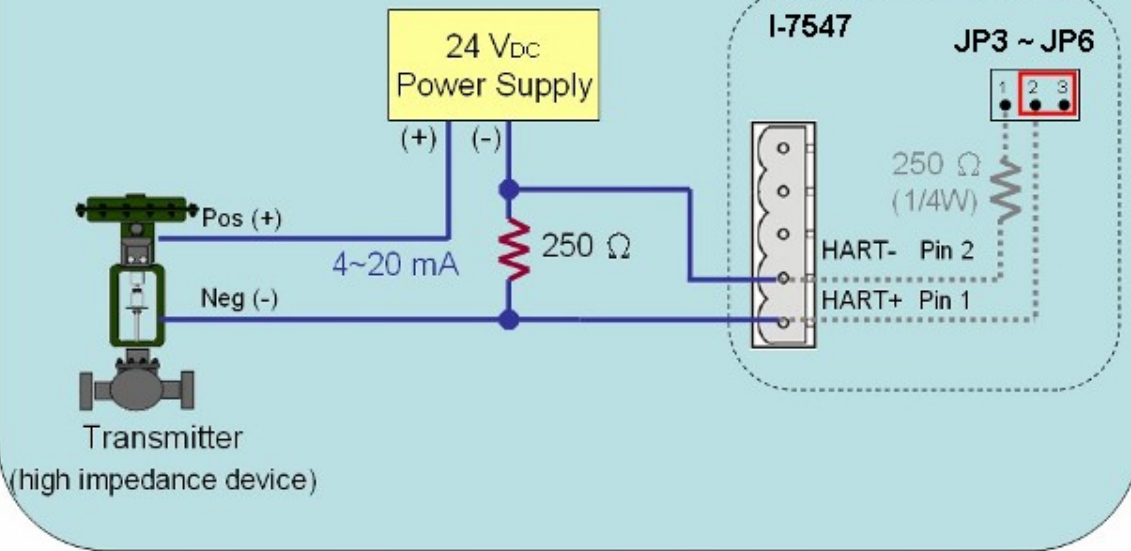

Ex2 : Loop Power Source (External Resistance)

## Loop Power Source (3) – external resistance

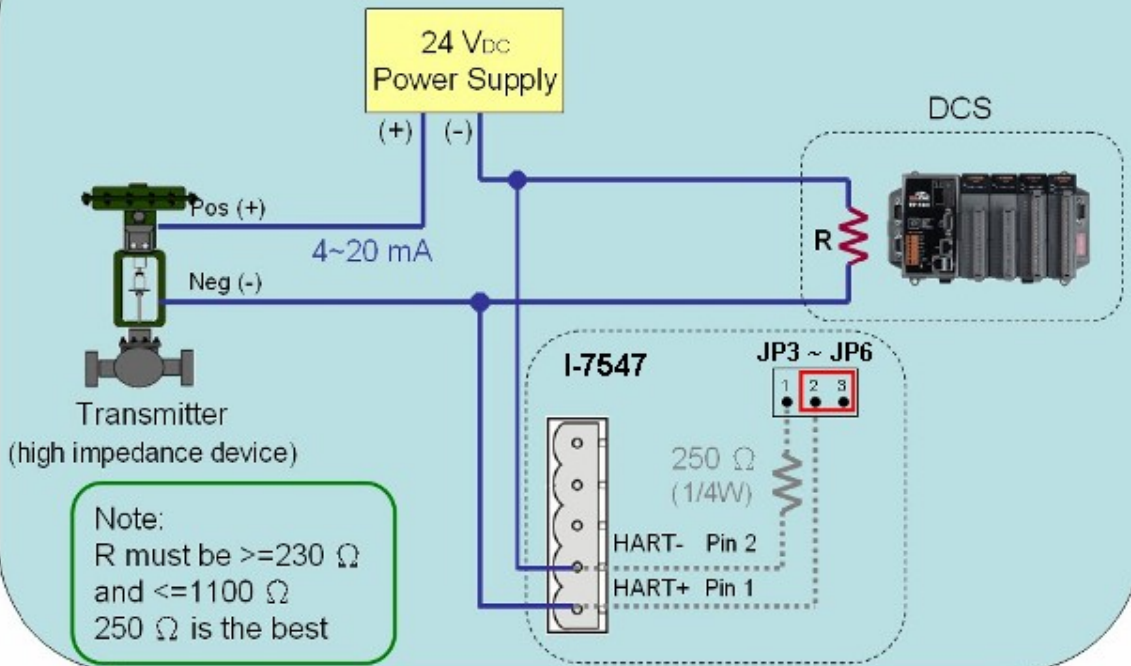

Ex3 : Loop Power Source (External Resistance)

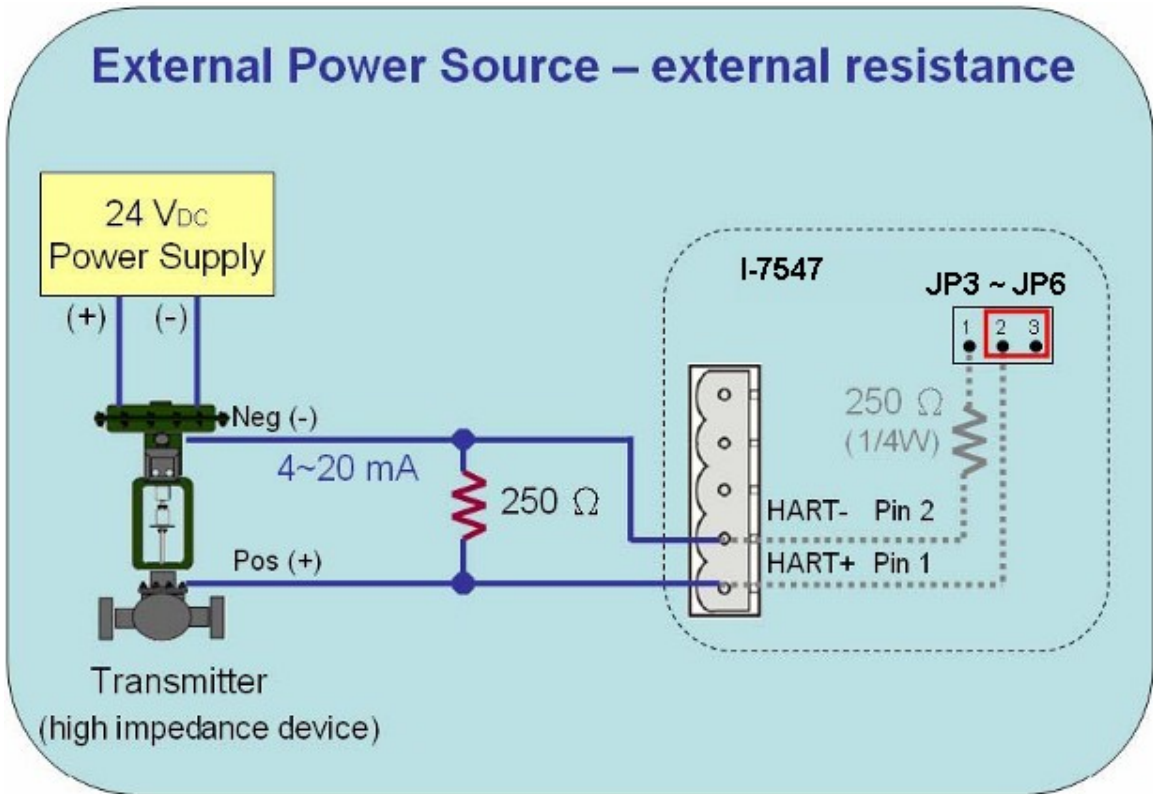

Ex4 : External Power Source (External Resistance)

## 2.2 Terminator Resistor Settings

In I-7547, there are four jumpers (JP3 ~ JP6) provided for four HART channels, shown as Figure 2-4. The jumper can select HART network with 250Ω (1/4 W) load resistor or not. When the pin 1&2 is connected, the resistor will be connected to HART network. When the pin 2&3 is connected, it will disconnect the resistor from HART network. By default, the pin1&2 is connected.

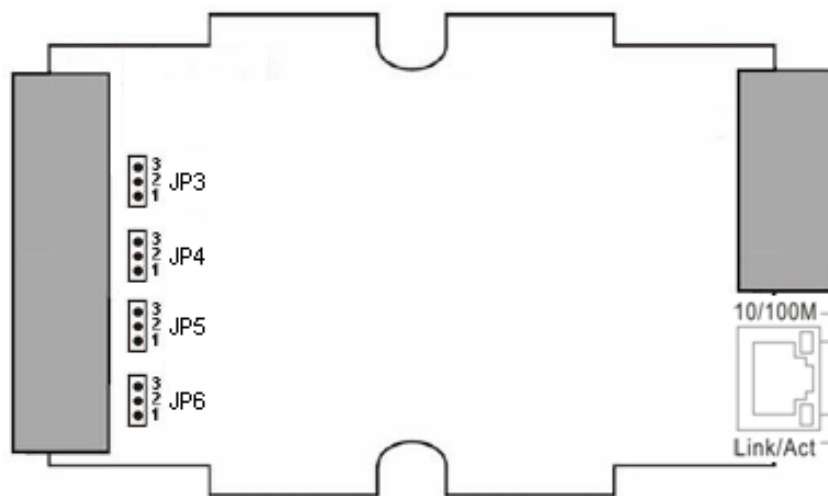

Figure 2-4: Internal Load Resistor

---

## 2.3 Init / Normal Dip-switch

There is a DIP switch on the back of the I-7547 module, as shown in Figure 2-5.

(1) **Firmware Update Mode :**

Set the DIP switch to the “Init” position.

(2) **Firmware Operation Mode :**

Set the DIP switch to the “Normal” position.

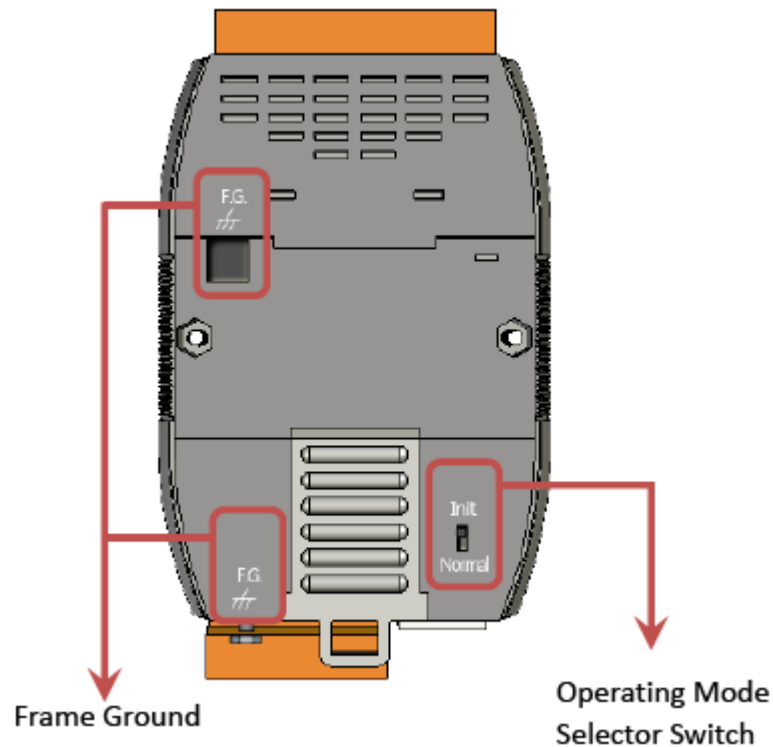

Figure 2-5: Dip Switch

### 2.3.1 Firmware Update Mode

Please follow the below steps to complete the firmware update process of I-7547.

- (1) Connect I-7547 to the same network with PC and make sure they can communicate with each other. (Please don't connect I-7547 to Internet, or it may cause the firmware update failure.)

- (2) Run “eSearch” Utility.

(Download : [ftp://ftp.icpdas.com/pub/cd/fieldbus\\_cd/hart/converter/i-7547/software/](ftp://ftp.icpdas.com/pub/cd/fieldbus_cd/hart/converter/i-7547/software/) and make sure the version is newer than v1.0.8)

Click “Search Servers” button to search I-7547 module automatically.

Click the right button of mouse on I-7547 item and choose

the "Firmware Update" option to start firmware update process.

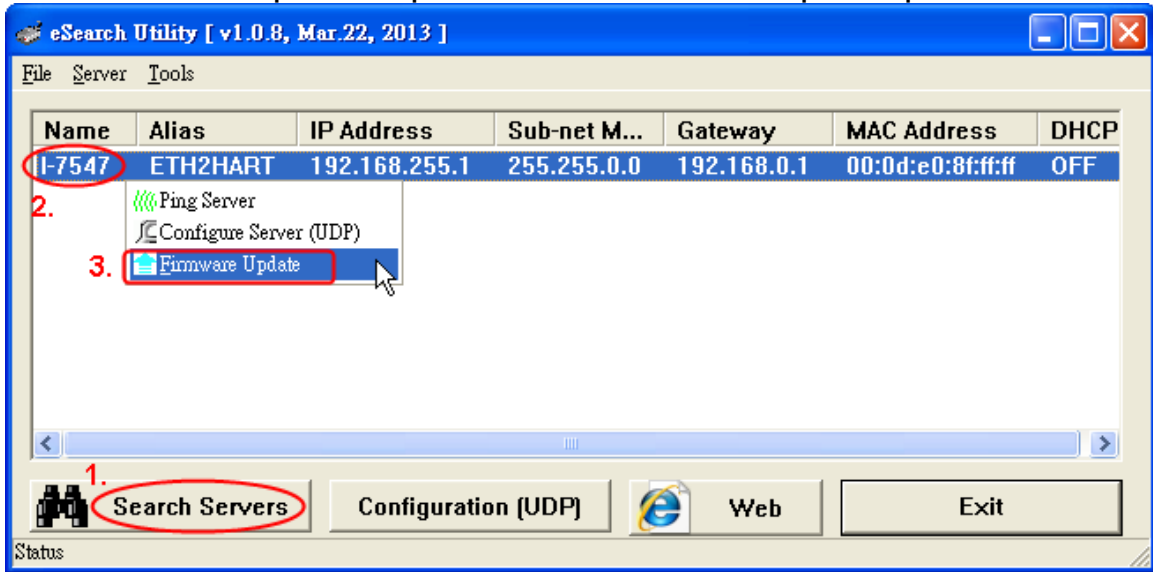

(3) Choose I-7547 firmware file.

(Download: [ftp://ftp.icpdas.com/pub/cd/fieldbus\\_cd/hart/converter/i-7547/firmware/](ftp://ftp.icpdas.com/pub/cd/fieldbus_cd/hart/converter/i-7547/firmware/))

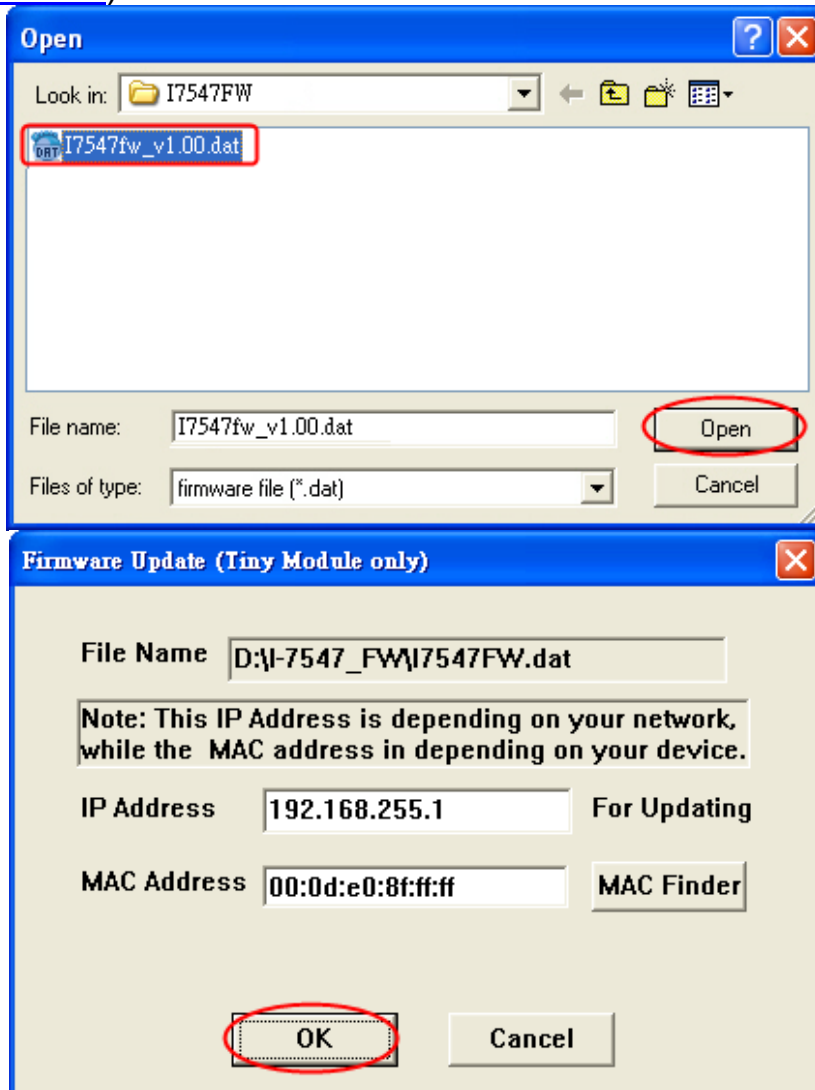

(4) In DOS command window, it will show the message for ready to update firmware.

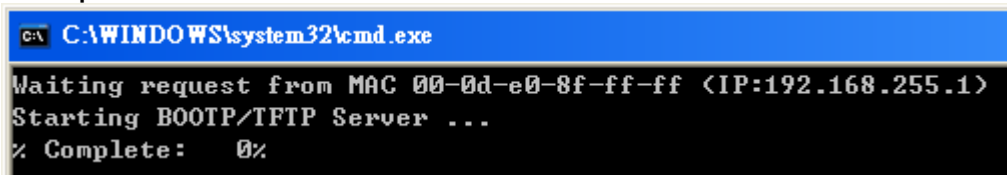

(5) Set the dip switch to the “Init” position and reboot I-7547. After that, it will start to update firmware automatically.

(6) After the process of firmware update finished, set the dip switch to the “Normal” position and reboot I-7547.

### 2.3.2 Firmware Operation Mode

Set the dip switch to the “Normal” position and then reboot I-7547. I-7547 will run in operation mode and then users can communicate with HART device via Ethernet.

## 2.4 LED Indication

There are two LEDs provided to indicate what situation the I-7547 is in. The Figure 2-6 is the illustration of these two LEDs.

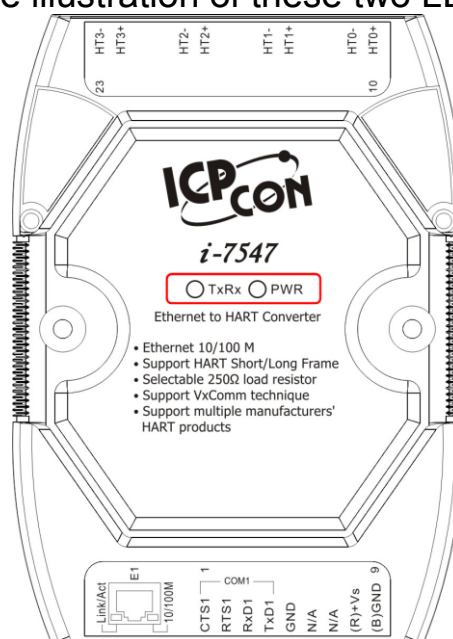

Figure 2-6: LED position of I-7547

---

### 2.4.1 LED Function

#### (1) PWR LED :

When power on I-7547, if I-7547 is in the firmware operation mode, then the PWR LED will be on. If I-7547 is in the firmware update mode, then after 5 seconds, I-7547 will change mode from update mode to operation mode. When turn off I-7547, the all LEDs will be off.

#### (2) TxRx LED :

When I-7547 received the data from Ethernet or HART port, then the TxRx LED will flash until the data received completed.

### 2.4.2 LED Indication Table

<b>Mode</b> <b>LED Name</b>	<b>Power off</b>	<b>FW Update</b>	<b>FW Operation</b>	<b>Ethernet Data Received</b>	<b>HART Port Data Received</b>
<b>PWR LED</b>	Off	On after 5 sec when reboot	On immediately when reboot	On	On
<b>TxRx LED</b>	Off	Off	Off	Flash	Flash

## 2.5 Cable Selection

The HART bus is a balanced (differential) 2-wire interface running over a Shielded Twisted Pair (STP), Un-shielded Twisted Pair (UTP), or Ribbon cable. How to decide a cable type, cable length, and terminator in the HART bus network, please refer to the following table.

No. Network Devices	Cable Capacitance – pf/ft (pf/m)			
	20 pf/ft (65 pf/m)	30 pf/ft (95 pf/m)	50 pf/ft (160 pf/m)	70 pf/ft (225 pf/m)
1	9,000 ft (2,769 m)	6,500 ft (2,000 m)	4,200 ft (1,292 m)	3,200 ft (985 m)
5	8,000 ft (2,462 m)	5,900 ft (1,815 m)	3,700 ft (1,138 m)	2,900 ft (892 m)
10	7,000 ft (2,154 m)	5,200 ft (1,600 m)	3,300 ft (1,015 m)	2,500 ft (769 m)
15	6,000 ft (1,846 m)	4,600 ft (1,415 m)	2,900 ft (892 m)	2,300 ft (708 m)

Allowable cable lengths for 1.0mm (#18 AWG) shield twisted pair

Note: The AWG means a standard method used to measure wire. The numbering system works backwards from what people would think, the thicker (heavier) the wire, the lower the number.



---

### 3. Web Server Configuration

I-7547 provides the built-in web server for module Ethernet parameter setting.

#### 3.1 Connect to I-7547 Web Server

##### [ Step 1: Input “IP Address” in the Web Browser ]

I-7547 supports many kinds of web browser like Mozilla, Firefox, Google Chrome and IE etc. The default IP address of I-7547 is “192.168.255.1”.

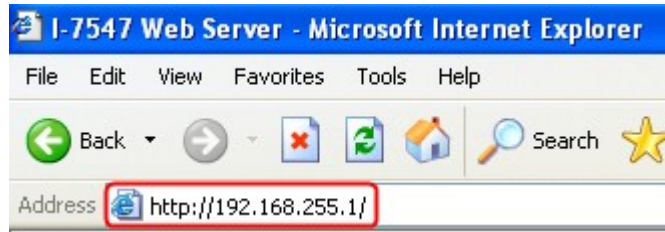

##### [ Step 2: Input “Password” in Log-In screen ]

When connecting to I-7547 web server, please input the password in the “Login password” field (Default Password : admin) and click “Submit” button to log in.

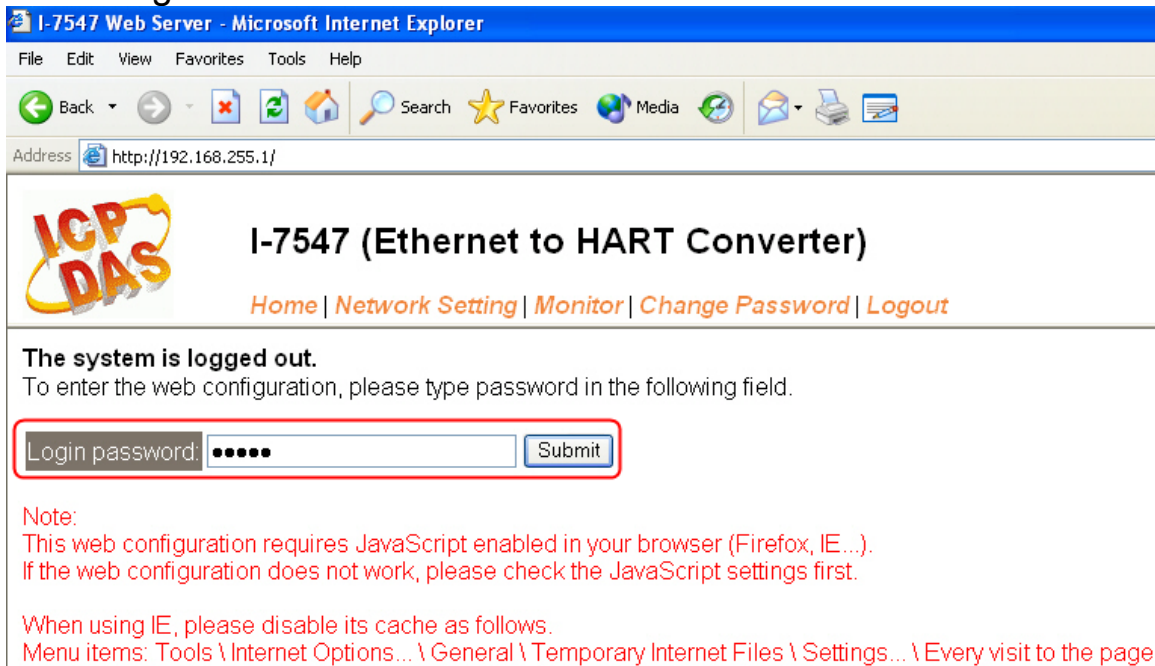

### 3.2 Home

Provide the basic software and hardware information of I-7547.



#### I-7547 (Ethernet to HART Converter)

[Home](#) | [Network Setting](#) | [Monitor](#) | [Change Password](#) | [Logout](#)

#### System Information

Model Name:	I-7547	Alias Name:	ETH2HART
Firmware Version:	v1.00 [2013/04/25]	MAC Address:	00-0d-e0-8f-ff-ff
IP Address:	192.168.255.1	TCP Command Port:	10000
Initial Switch:	OFF	System Timeout: (Network Watchdog, Seconds)	300

### 3.3 Network Setting

Provide the below configuration.

#### (1) IP Address Setting:

Provide module Ethernet communication configuration.

<b>IP Address</b>	
Address Type:	Static IP <input type="button" value="v"/>
Static IP Address:	<input type="text" value="192"/> . <input type="text" value="168"/> . <input type="text" value="255"/> . <input type="text" value="1"/>
Subnet Mask:	<input type="text" value="255"/> . <input type="text" value="255"/> . <input type="text" value="0"/> . <input type="text" value="0"/>
Default Gateway:	<input type="text" value="192"/> . <input type="text" value="168"/> . <input type="text" value="0"/> . <input type="text" value="1"/>
MAC Address:	<input type="text" value="00-0d-e0-8f-ff-ff"/> (Format: FF-FF-FF-FF-FF-FF)
<b>Virtual COM</b>	
TCP Command Port:	<input type="text" value="10000"/> (Default: 10000)
Command Port Timeout: (Socket Watchdog)	<input type="text" value="180"/> (1 ~ 65535 seconds, 30=default, 0=disable)
<input type="button" value="Update Settings"/>	

Items	Description
<b>Address Type</b>	<b>[ Static IP ]</b> If there is no DHCP server in the network, then static IP can be assigned to I-7547.

**[ DHCP / AutoIP ]**

If there is a DHCP server in the network, then I-7547 can be assigned to the IP address automatically. When I-7547 reboots, the IP address of I-7547 assigned by the DHCP server may be different.

<b>Static IP Address</b>	Set the static IP address.
<b>Subnet Mask</b>	Set the subnet mask.
<b>Default Gateway</b>	Set the gateway.
<b>MAC Address</b>	Set the user-defined MAC address.
<b>TCP Command Port</b>	Default TCP command port is 10000.
<b>Command Port Timeout (Socket Watchdog)</b>	If command port doesn't receive any TCP/IP data within the timeout, then I-7547 will be disconnected automatically. Range : 1~65535 (seconds); Default : 30 (seconds); Disabled = 0
<b>Update Settings</b>	Click the button to save the new settings to I-7547.

**(2) General Setting:**

Provide the general module configuration like module alias, watchdog and web auto-logout etc. function.

<b>Network</b>	
System Timeout: (Network Watchdog)	<input type="text" value="300"/> (30 ~ 65535 seconds, 300=default, 0=disable) Action=Reboot
Web Auto-logout:	<input type="text" value="10"/> (1 ~ 255 minutes, 10=default, 0=disable)
CGI Configuration:	<input type="button" value="Enable"/> (Enable/Disable the assign.cgi, Enable=default.)
<b>UDP Alarm</b>	
Alarm IP Address(UDP):	<input type="text" value="255"/> . <input type="text" value="255"/> . <input type="text" value="255"/> . <input type="text" value="255"/>
Alarm Port(UDP):	<input type="text" value="54300"/>
<b>Misc.</b>	
Alias Name:	<input type="text" value="ETH2HART"/> (Max. 18 chars)
UART Watchdog:	Tx: <input type="text" value="0"/> Rx: <input type="text" value="0"/> (30 ~ 65535 seconds, 0=default=disable) Action=Reboot
Debug Message(UDP):	<input type="text" value="20"/> (1 ~ 255 seconds, 20=default, 0=disable)
<input type="button" value="Update Settings"/>	

Items	Description	Default
<b>Alias Name</b>	Set the module alias for easy identification in the network.	ETH2HART
<b>System Timeout (Network WDT)</b>	Set the system timeout value. (When I-7547 error happened and lost communication, it will reboot automatically after system timeout value passed.) Range : 30~65535 (seconds); Disabled = 0;	300
<b>Web Auto-logout</b>	Set the timeout value for web auto-logout. (If there is no any action in I-7547 web server within the web auto-logout timeout value, then it will log out automatically.) Range : 1~65535 (minutes); Disabled = 0;	10
<b>Update Settings</b>	Click the button to save the new settings to I-7547.	

### (3) Restore Factory Defaults:

Provide to restore the factory default settings of I-7547.

- [1] Click “Restore Defaults” button to restore the factory default settings.



- [2] Click “OK” button to finish the setting.

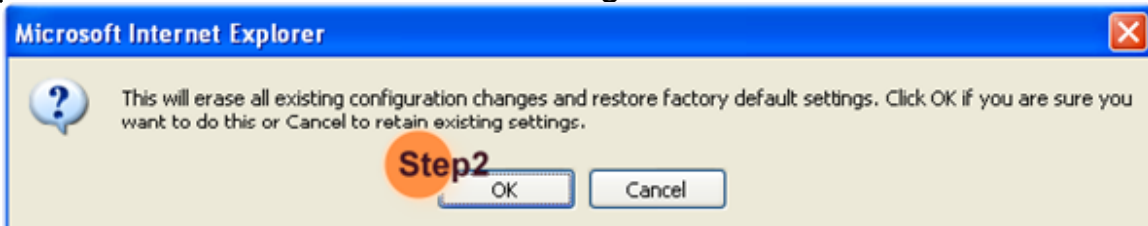

Items	Factory Default
IP	192.168.255.1
Gateway	192.168.0.1
Mask	255.255.0.0

**(4) Forced Reboot:**

Provide to remote reboot I-7547 module via web.

**3.4 Monitor**

Provide the connection status and communication data length of the "Ethernet to COM" and "Ethernet to HART" function.



**I-7547 (Ethernet to HART Converter)**

[Home](#) | [Network Setting](#) | **[Monitor](#)** | [Change Password](#) | [Logout](#)

**Connection Status (Ethernet) :**

Port Number	COM 1	HART
Client/Server Mode:	Server	Server
Connected IP1:	192.168.255.203	192.168.255.203
IP2:	0.0.0.0	0.0.0.0
IP3:	0.0.0.0	0.0.0.0
IP4:	0.0.0.0	0.0.0.0

- (1) COM1: The VxComm connection status of "Ethernet to COM".
- (2) HART: The VxComm connection status of "Ethernet to HART".

**Tx/Rx Count (COM/HART) :**

Port Number	COM 1	HART
Last Tx Count (bytes):	0	0
Last Rx Count (bytes):	0	0
Total Tx Count (bytes):	14	55
Total Rx Count (bytes):	21	0

- (1) COM1: The Tx/Rx byte count of "Ethernet to COM".
- (2) HART: The Tx/Rx byte count of "Ethernet to HART".

### 3.5 Change Password

Provide the new password setting for web server login.



## I-7547 (Ethernet to HART Converter)

[Home](#) | [Network Setting](#) | [Monitor](#) | **[Change Password](#)** | [Logout](#)

### Change Password

The length of the password is 12 characters maximum.

Current password:	<input type="password" value="....."/>
New password:	<input type="password" value="....."/>
Confirm new password:	<input type="password" value="....."/> <input type="button" value="Submit"/>

Items	Description
Current password	Input the old password. (Default : admin)
New password	Input the new password.
Confirm new password	Input the new password again.
Submit	Click the button to save the new settings to I-7547.

### 3.6 Logout

When click the “Logout” label, it will logout the web server of I-7547 automatically and connect to the login screen.



## I-7547 (Ethernet to HART Converter)

[Home](#) | [Network Setting](#) | [Monitor](#) | [Change Password](#) | **[Logout](#)**

**The system is logged out.**

To enter the web configuration, please type password in the following field.

Login password:	<input type="password"/>	<input type="button" value="Submit"/>
-----------------	--------------------------	---------------------------------------

## 4. HC\_Tool Utility

### 4.1 VxComm Utility

Before using HC\_Tool utility to communicate with I-7547, please install the “VxComm Utility” software first to create a virtual com port.

(1) Install the “VxComm Utility”.

(Download: [ftp://ftp.icpdas.com/pub/cd/fieldbus\\_cd/hart/converter/i-7547/software/](ftp://ftp.icpdas.com/pub/cd/fieldbus_cd/hart/converter/i-7547/software/) and make sure the version is newer than v2.12) °

(2) Run the “VxComm Utility”.

Click the “Search Servers” button to search all I-7547 modules automatically.

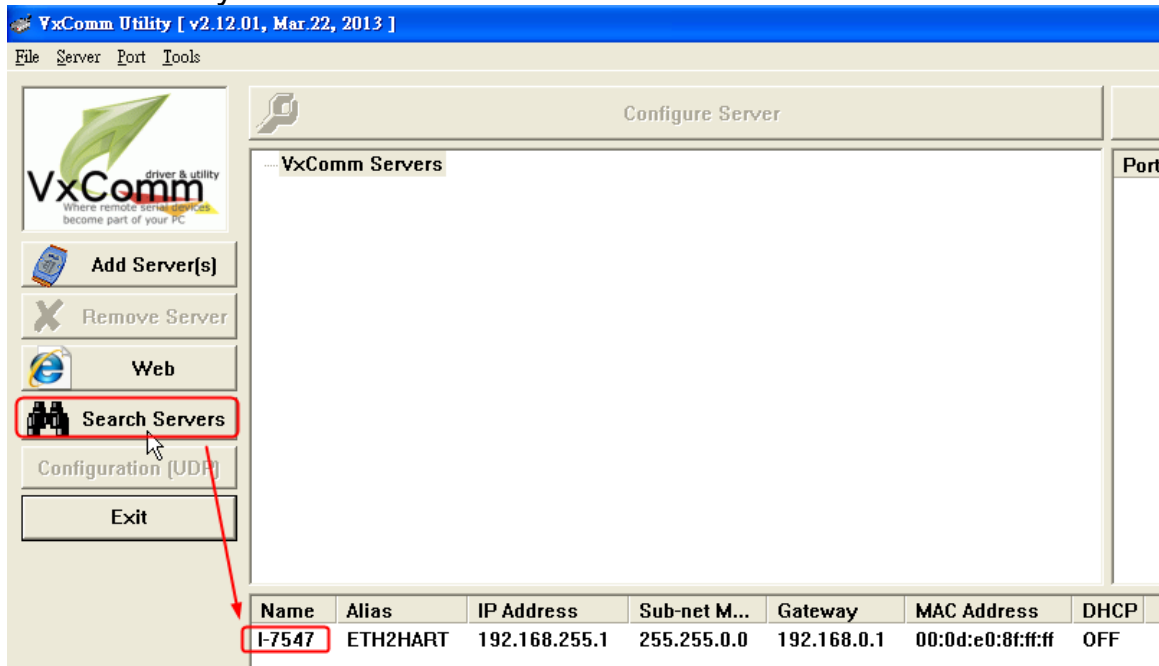

(3) Click the right button of mouse on the “I-7547” item and choose the “Add Server(s)” option.

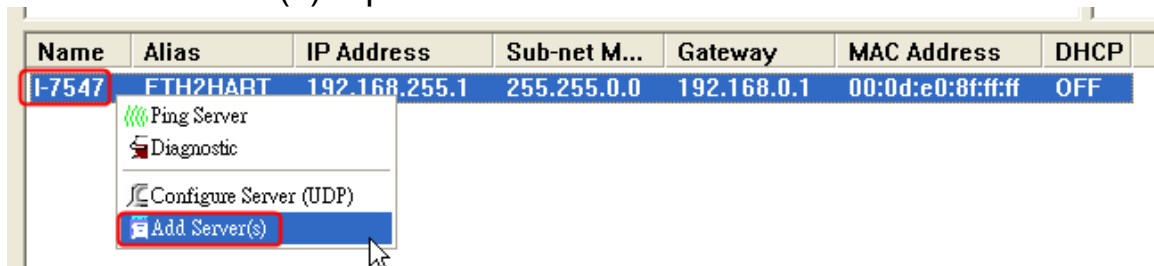

(4) In “COM Port:” item, choose the com port number.

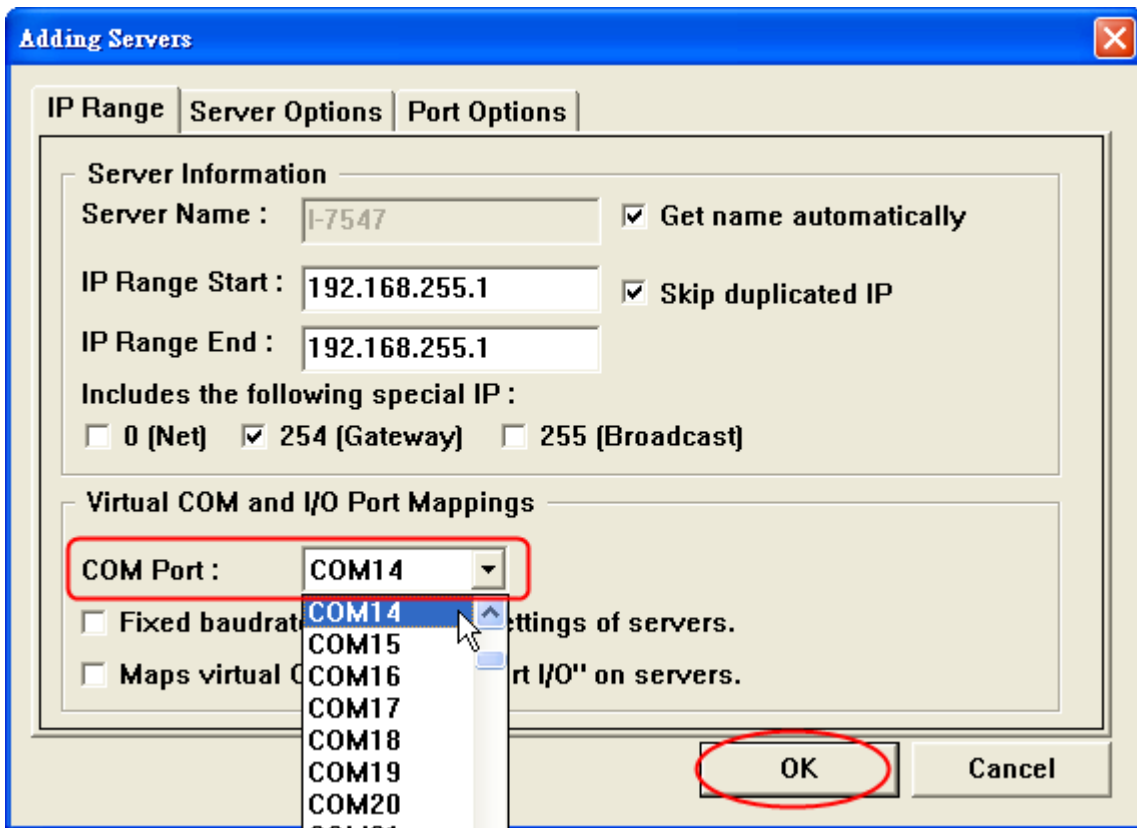

(5) If success, the "I-7547" item will be listed in the above "VxComm Servers" list. The virtual com port will be shown in the right field like Port1 and Port2.

- [1] Port 1 (COM14) : The virtual com port for Ethernet to COM.
- [2] Port 2 (COM15) : The virtual com port for Ethernet to HART.

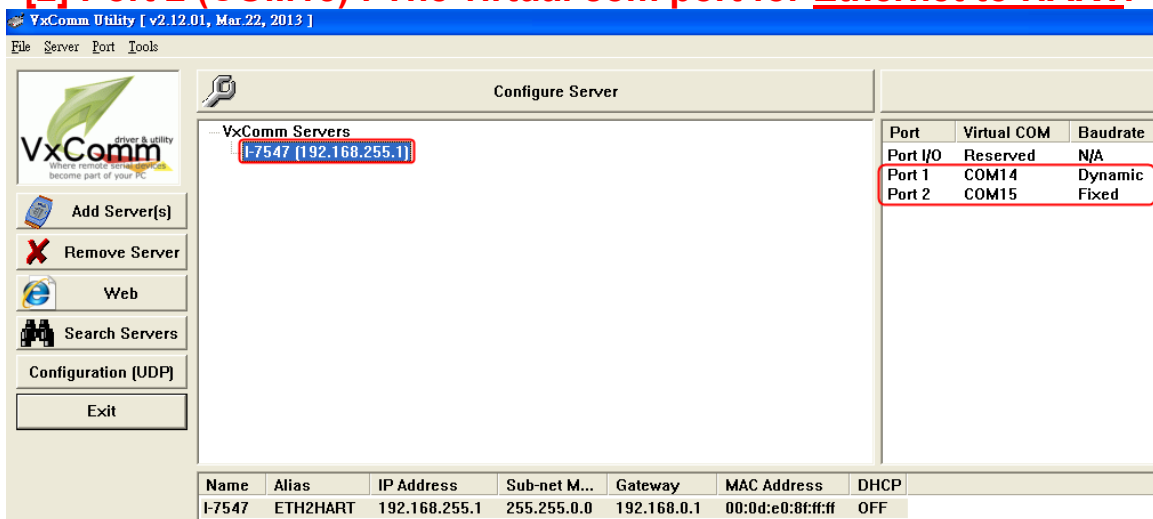

(6) Click "Tools" item and choose the "Restart Driver" option and then it will enable the virtual com port settings.



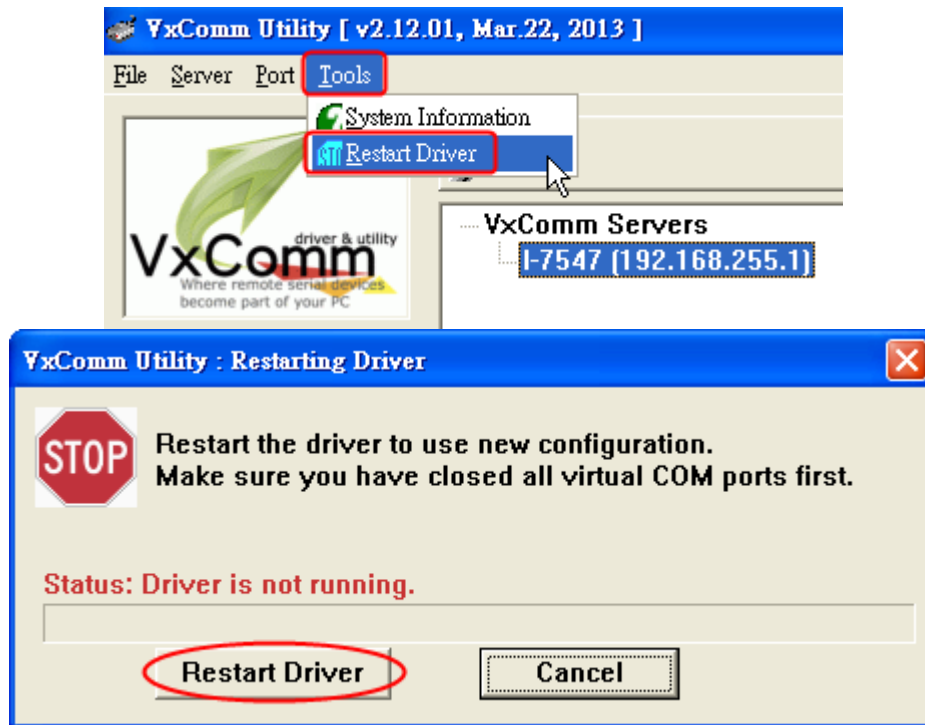

## 4.2 Run HC\_Tool

HC\_Tool utility is provided to configure ICP DAS all HART converter modules (like I-7567 / I-7570 / I-7547) or transmit / receive HART frame for HART communication easily and quickly. HC\_Tool utility can be downloaded from the ICP DAS web site :

[http://ftp.icpdas.com/pub/cd/fieldbus\\_cd/hart/converter/i-7547/software/](http://ftp.icpdas.com/pub/cd/fieldbus_cd/hart/converter/i-7547/software/).

Run the “HC\_Tool”, like Figure 4-1. If users can’t run “HC\_Tool”, please install .NET Framework 3.5 first.

(<http://www.microsoft.com/downloads/details.aspx?familyid=333325FDAE52-4E35-B531-508D977D32A6&displaylang=en> ).

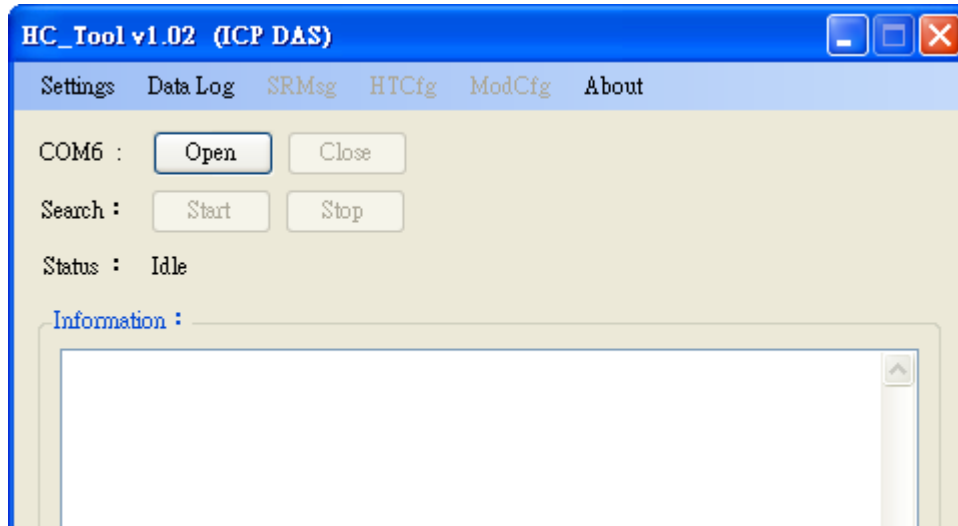

Figure 4-1: HC\_Tool Utility

### 4.3 Serial Port and HART Command Settings

Please click “**Settings**” item to open setting window of serial port and HART parameters like Figure 4-2.

#### 4.3.1 Serial port settings

(1) Please select serial port no. of PC like Figure 4-2.

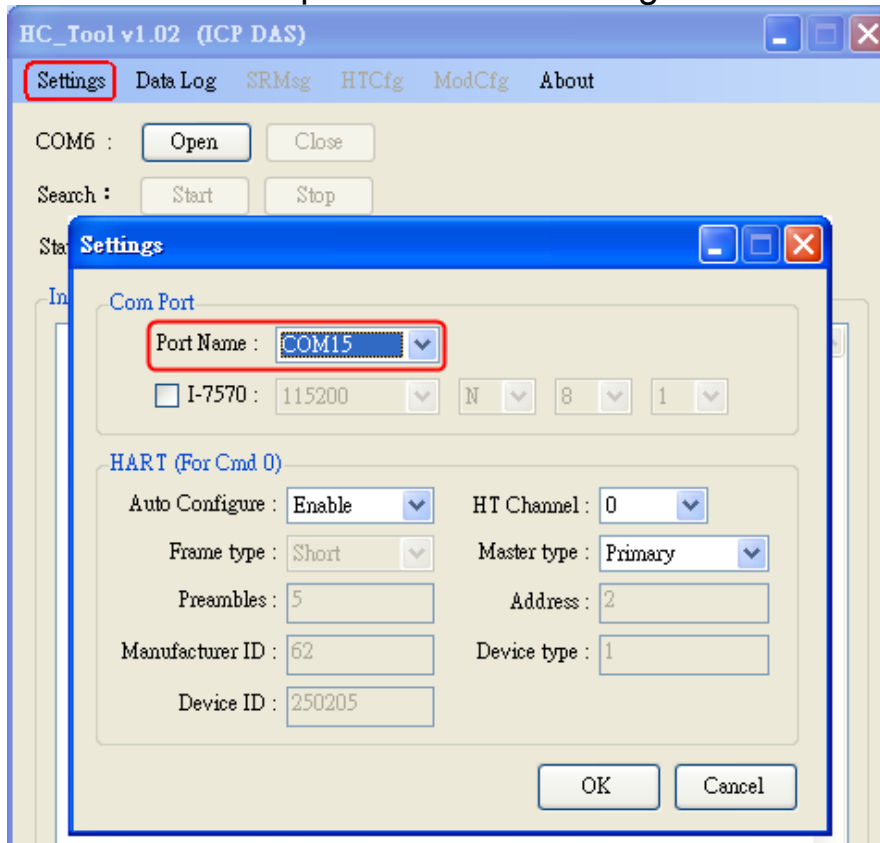

Figure 4-2: Set Serial Port No.

### 4.3.2 HART Frame Settings

The following is the description of HART command fields.

**Auto Configure** : (1) Enable : search HART devices automatically.

(2) Disable : search HART devices according to manual parameters.

**HT Channel** : Select HART channel no.

**Frame type** : Select HART frame format (Short/Long).

**Master type** : Select Primary master or Secondary master.

**Preambles** : Select 5~20 bytes (0xFF) number.

**Address** : Select HART Polling Address (0~15).

**Manufacturer ID**: Manufacturer Identification Code

**Device type** : Manufacturer Device Type Code

**Device ID** : Manufacturer Device Identification Code.

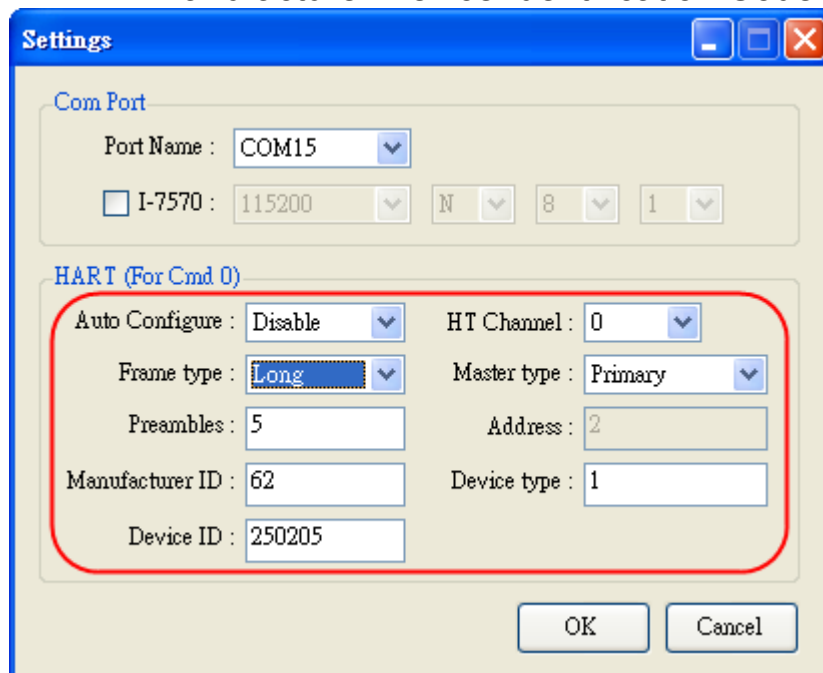

Figure 4-3: Set HART Frame Format

## 4.4 Search HART devices

### 4.4.1 Search HART devices automatically

Set the option of “Auto Configure” field to be “Enable” and the option of “Master type” field to be “Secondary” like Figure 4-4. Then HC\_Tool utility will automatically search all HART devices by using HART short

frame with “Secondary Master” identity.

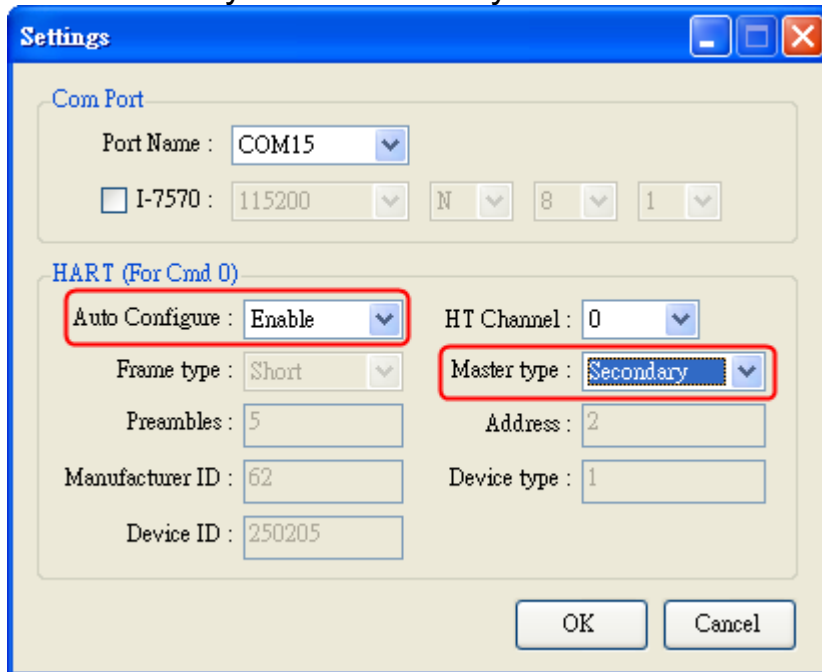

Figure 4-4: Auto Configure - Enable

#### 4.4.2 Search HART devices by manual

Set the option of “Auto Configure” field to be “Disable” and then users can set the HART frame by manual to search HART devices.

- (1) If the option of “Frame type” field is “Short”, then “Master type”, “Preambles”, “Address” fields need to be configured like Figure 4-5.

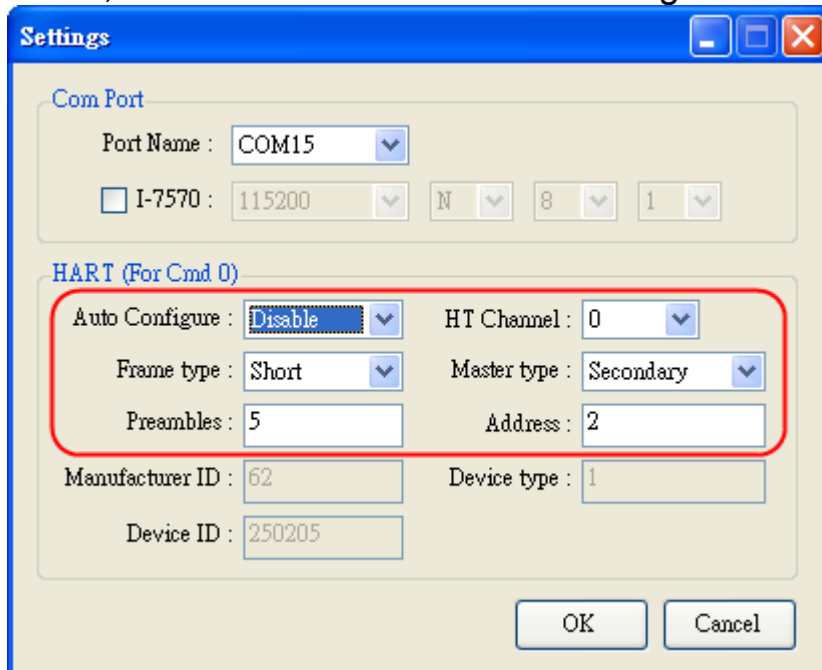

Figure 4-5: Short frame settings

- (2) If the option of “Frame type” field is “Long”, then “Master type”, “Preambles”, “Manufacturer ID”, “Device type”, “Device ID” fields need to be configured like Figure 4-6.

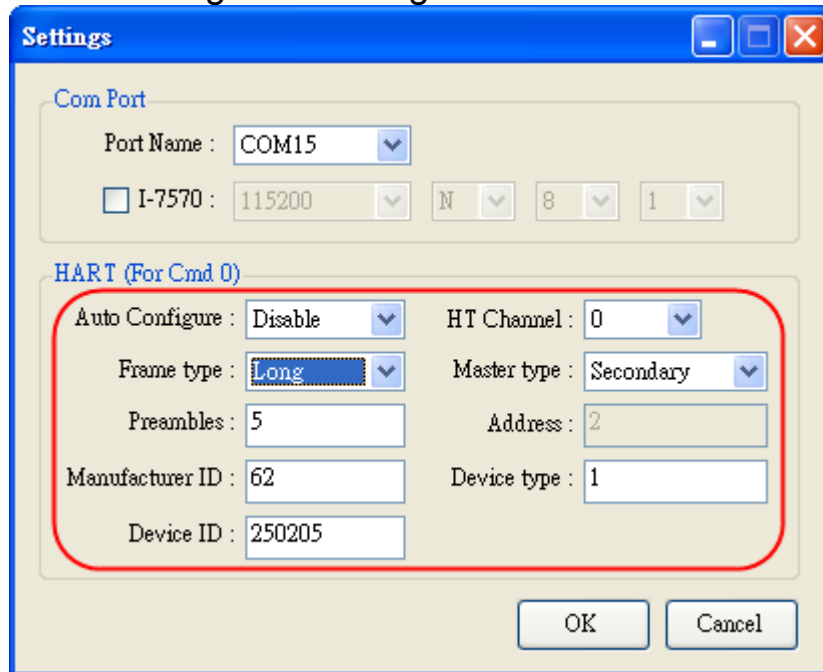

Figure 4-6: Long frame settings

If the setting of serial port and HART frame format is finished, please click the “OK” button. Then users can test the HART communication.

#### 4.4.3 Search HART devices

- (1) Click “**Open**” button to open the com port of PC like Figure 4-7. If com port open failed, please check the com port setting.

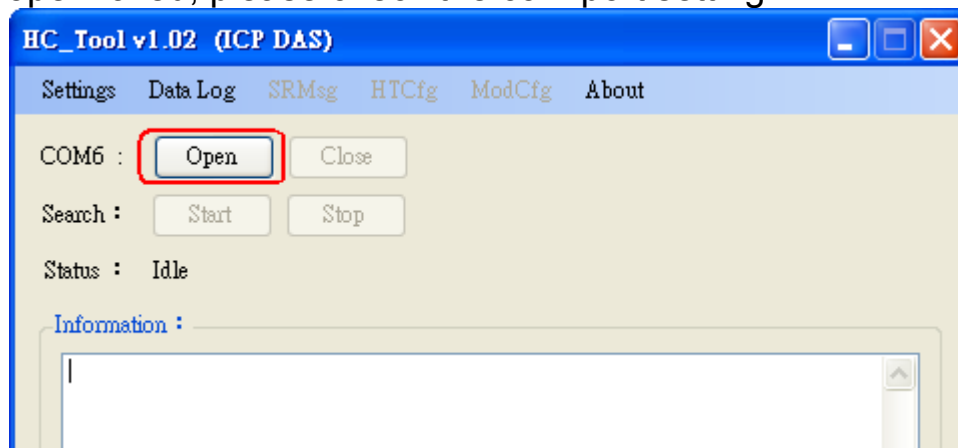

Figure 4-7: Click “Open” button

- (2) Click “**Start**” button to search all HART devices and the result will be

shown in the "Information" field like Figure 4-8.

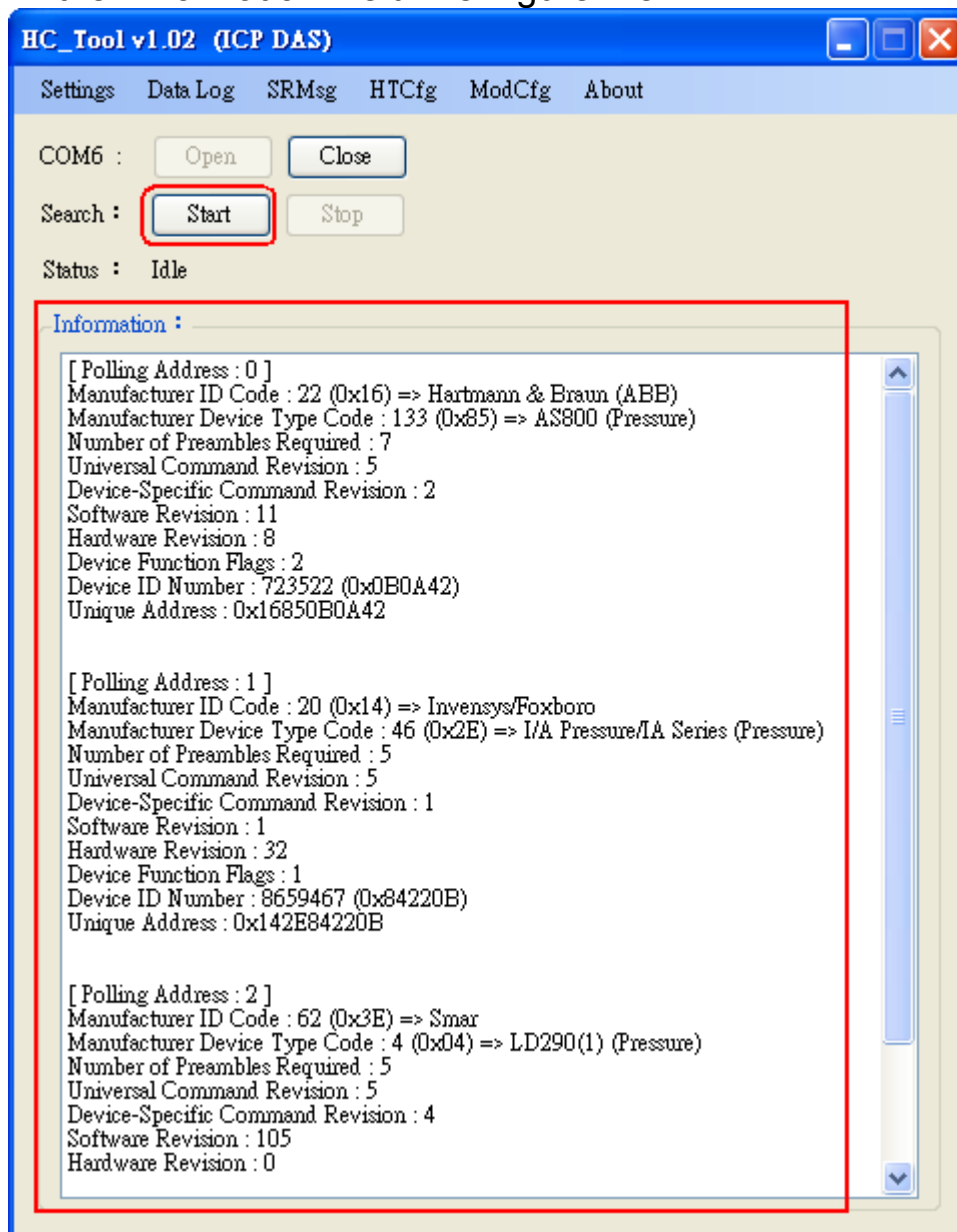

Figure 4-8: HART device Information

If the error message - "Search Device Failed !!" shows like Figure 4-9, please check HART network status and HART command format.

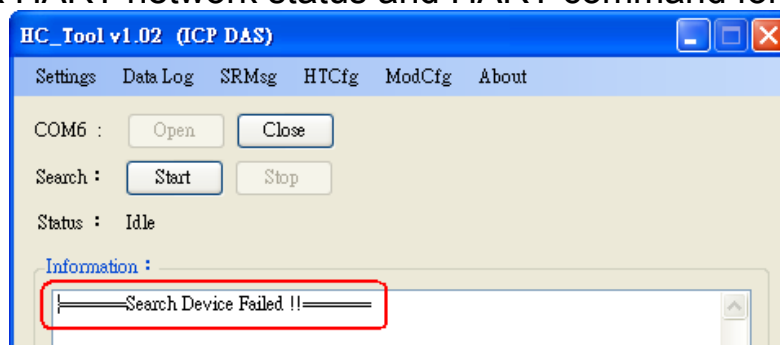

Figure 4-9: Search Device Failed

## 4.5 Send / Receive HART Frame (SRMsg)

- (1) Click “**SRMsg**” item and it will open the HART command function window for HART communication like Figure 4-10.

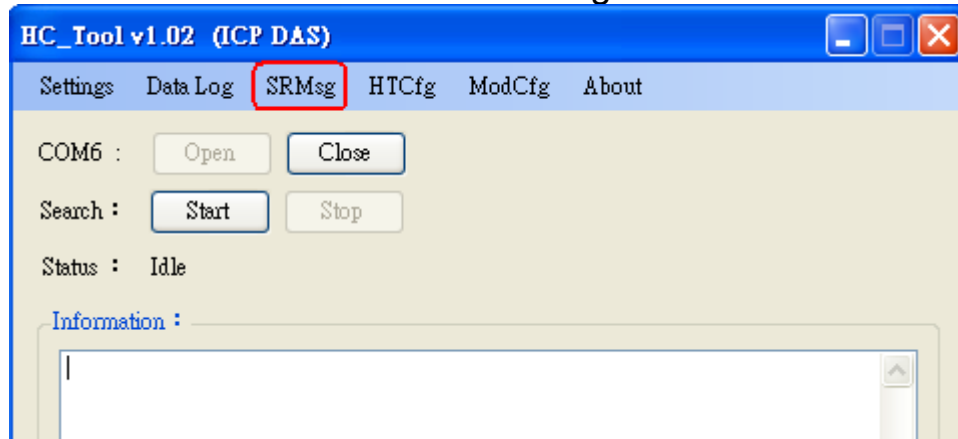

Figure 4-10: SRMsg Function

- (2) Please type the HART command in the "Send Data" field and click "Send" button to send out the HART command like Figure 4-11.

[1] “**With Parity Check**” item :

When check the item, it will add the “check byte” automatically while sending the HART frame.

[2] “**Auto Scroll**” item :

When check the item, it will scroll the HART message field automatically to show the latest HART message information.

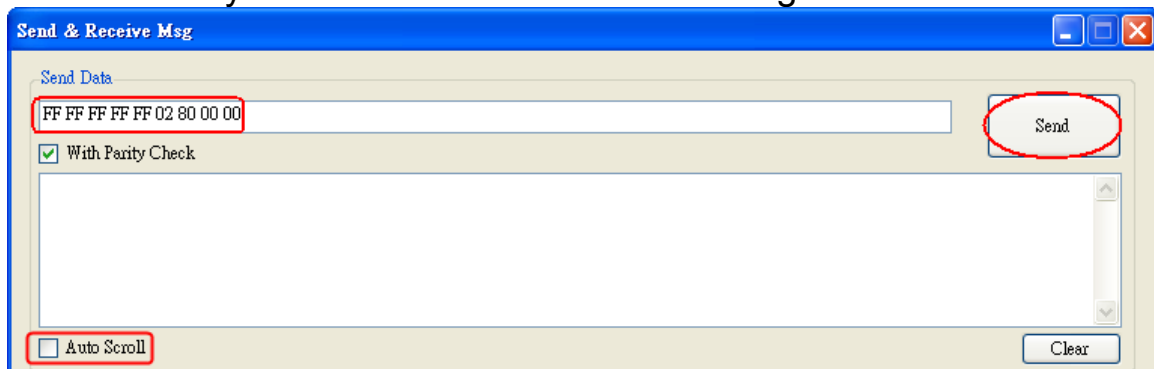

Figure 4-11: Send HART Command

- (3) When HART device responses the HART information, it will show in the "Receive Data" field like Figure 4-12. If error happened in HART communication, it will not show any message in the "Receive Data" field. Please check the HART command in the "Send Data" field if it is correct.

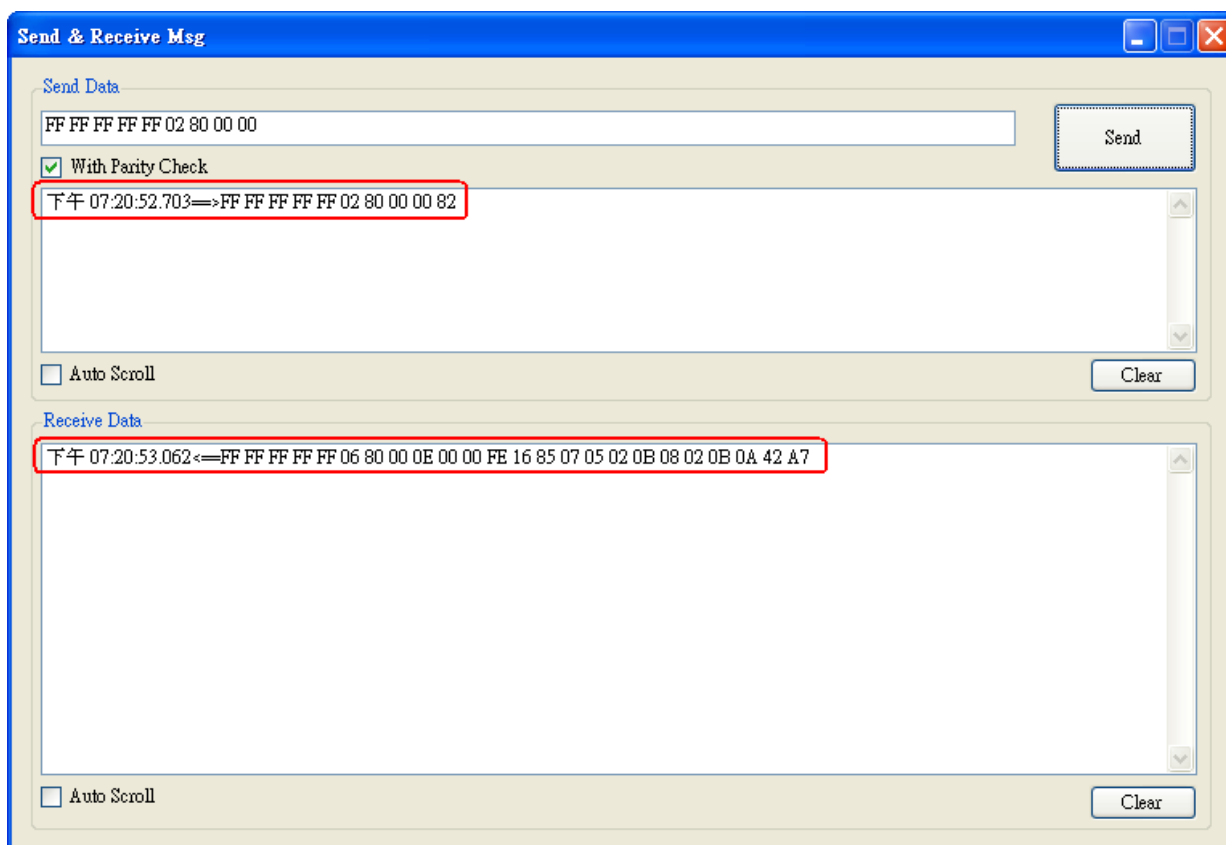

Figure 4-12: Receive HART Command

## 4.6 HART Information Log (Data Log)

When using "SRMsg" or "Start" function for HART communication, all the HART command information will be logged in the "Data Log" function. Users can click "**Data Log**" item and all the HART communication information will be shown in "Log" field like Figure 4-13.



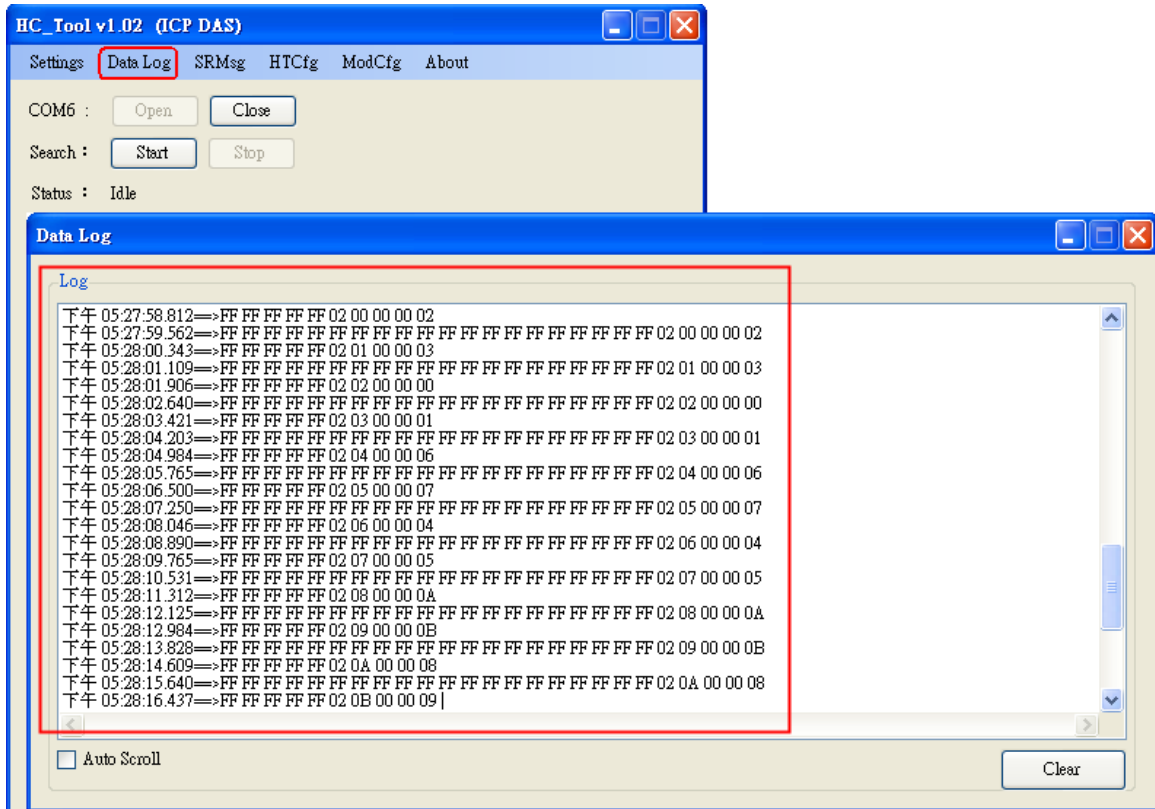

Figure 4-13: HART Information Log

#### 4.7 HART Configuration (HTCfg)

When HART devices are searched in HC\_Tool, then users can use “HTCfg” function to configure HART devices like Figure 4-14.

(Supported by HC\_Tool v1.02 or newer)

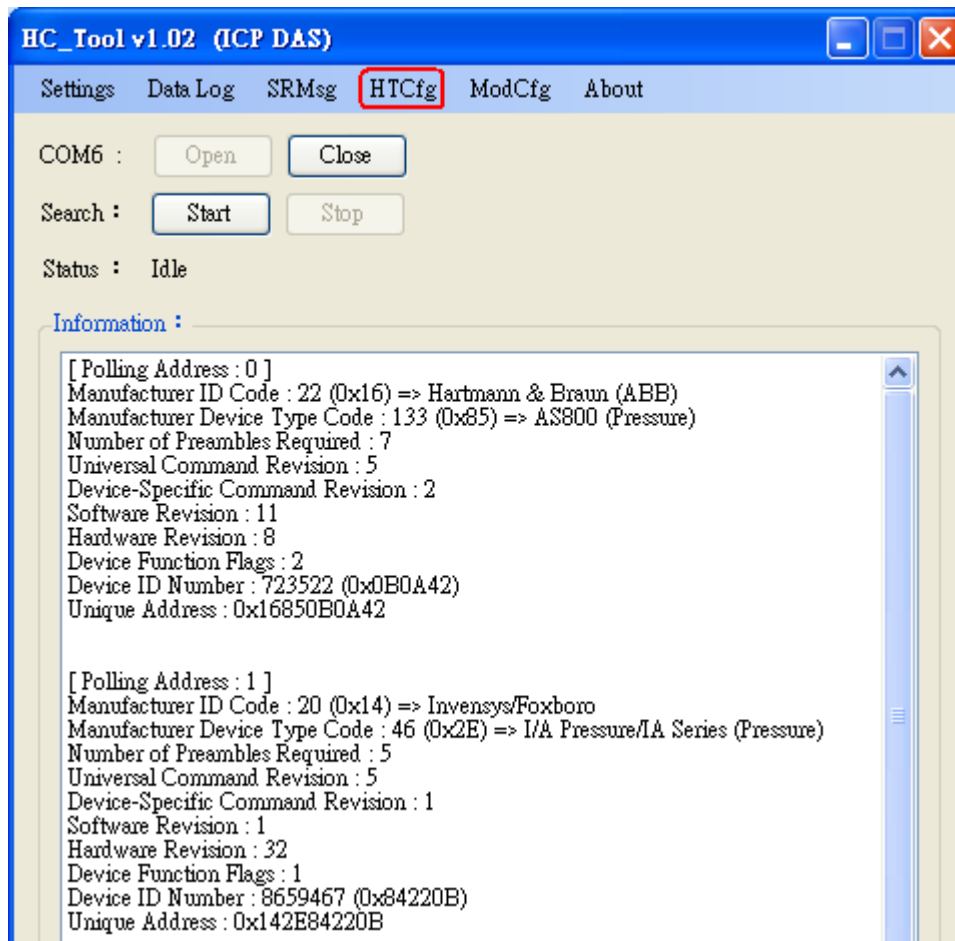

Figure 4-14: HTCcfg Item

The following is the function description of “HTCcfg” screen. (Like Figure 4-15)

- (1) “**DevAddr**” Field: Assign the HART device for configuration.
- (2) “**Response**” Field: Show the response message of HART configuration command.
- (3) “**Universal**” Page: Choose the “Universal” command for configuration.  
(Support HART Command version v6.0)
- (4) “**Common**” Page: Choose the “Common-Practice” for configuration.  
(Support HART Command version v6.0)
- (5) “**Start**” Button: Trig to send the HART configuration command.
- (6) “**Listen Mode**” item: Check it and click the ”Start” button, HC\_Tool will listen HART bus and show the received HART message information.
- (7) “**HART RecvMsg Count**” Area: Show the total count of the received HART messages. (Including Master sending message and Slave response message)

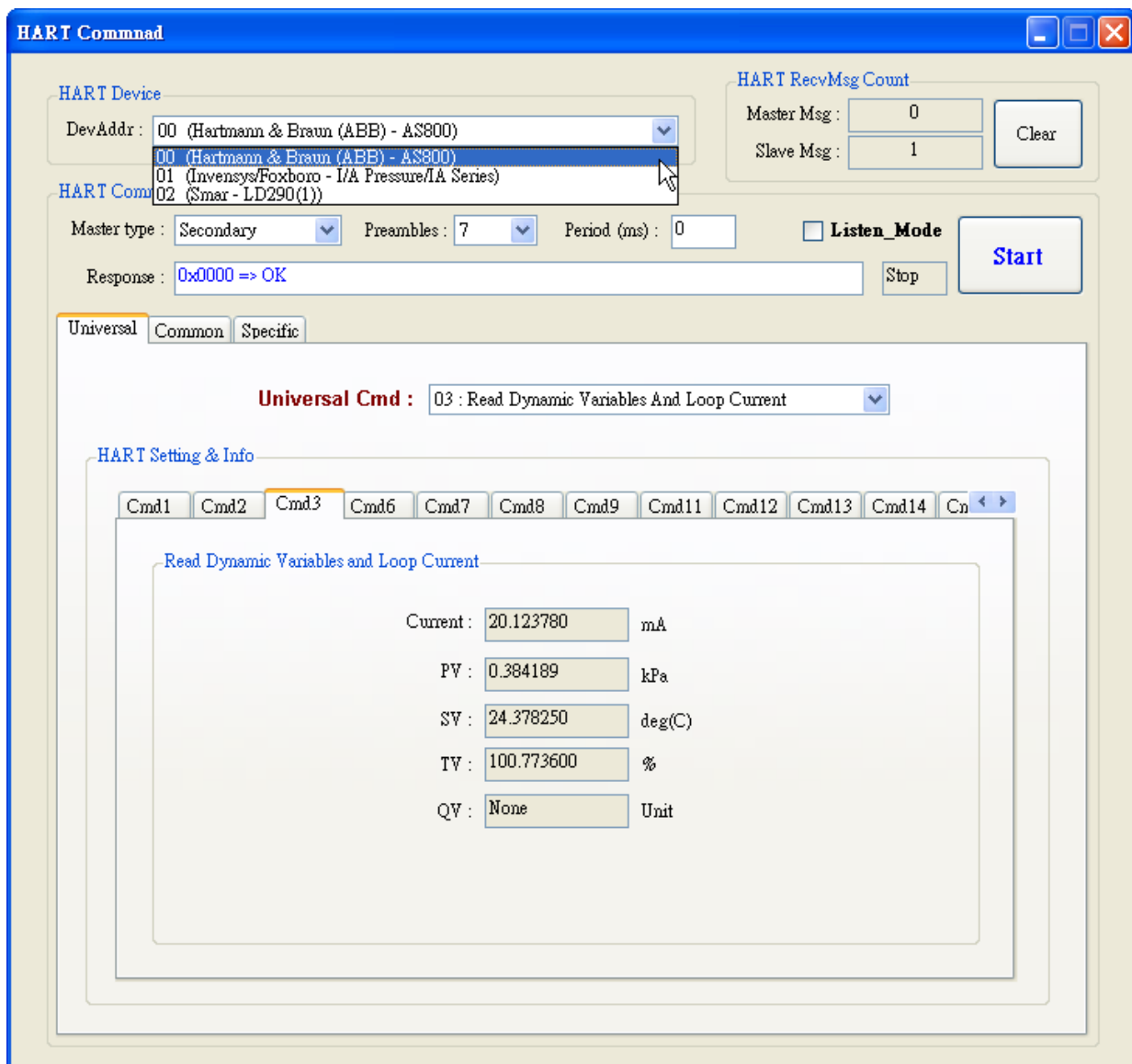

Figure 4-15: HTCfg Screen

## 4.8 Module Configuration (ModCfg)

Click "**ModCfg**" item, it will show the below two options to open the module configuration screen of HART Converter like Figure 4-16.

- (1) HC\_Tool : v1.02 or newer supported.
- (2) I-7567 : FW\_v1.5 or newer supported.
- (3) I-7570 : FW\_v1.4 or newer supported

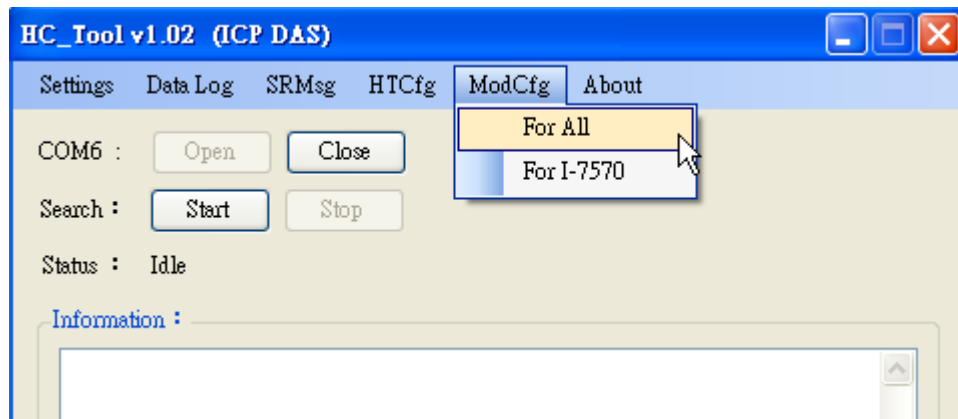

Figure 4-16: ModCfg Item

The following is the function description of “ModCfg”.

**1. “For All” Option : (Like Figure 4-17)**

**Note : It is used for all HART Converter modules**

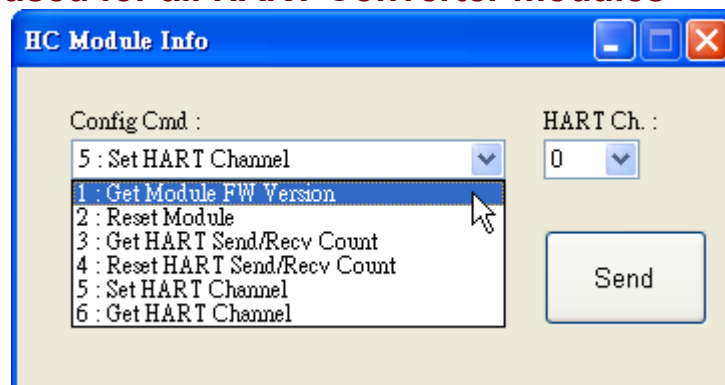

Figure 4-17: “For All” Option - Configuration Screen

**(1) “Get Module FW Version”:**

=> Return the firmware version of HART converter module.

**(2) “Reset Module”:**

=> Reset HART converter module.

**(3) “Get HART Send/Recv Count”:**

=> Return the total count of the sending and receiving HART messages in HART converter module.

**(4) “Reset HART Send/Recv Count”:**

=> Reset the total count of the sending and receiving HART messages in HART converter module.

**(5) “Set HART Channel”:** (Only for I-7547)

=> Set the HART channel (Range: 0 ~ 3) of I-7547 for HART communication by using “HART Ch” option.

Users can also set the HART channel by send com port command.

For example:

Send Command => **#C52\r** (Set HART channel to be 2)

Return Data => **!C5\r** (Success)

Return Data => **?02\r** (Failure)

[Note]

1. Only one HART channel in I-7547 can be used to communicate with HART device in the same time.

**(6) “Get HART Channel”: (Only for I-7547)**

=> Return the HART channel (Range: 0 ~ 3) of I-7547.

Users can also get the HART channel by send com port command.

For example:

Send Command => **#C6\r**

Return Data => **!C6\_2\r** (The current HART channel is 2.)

**2. “For I-7570” Option : (Like Figure 4-18)**

**Note : It is just used to I-7570 module and make sure the I-7570 must run in “Config Mode” first.**

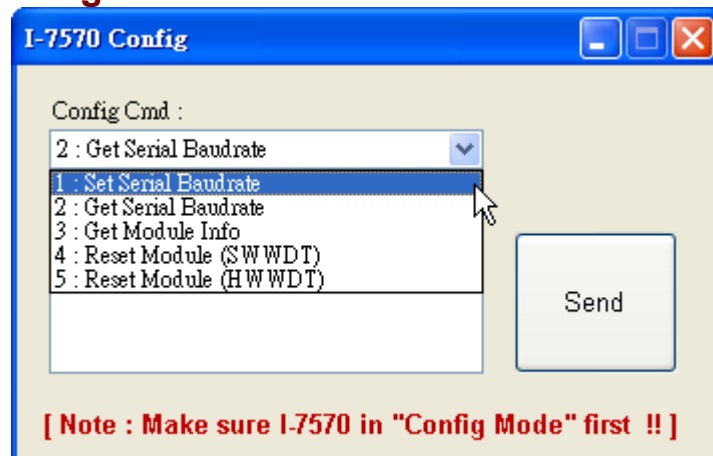

Figure 4-18: “For I-7570” Option - Configuration Screen

---

## 5. History Version

<b>Ver.</b>	<b>Author</b>	<b>Date</b>	<b>Description</b>
1.0	Edward	2013/08/27	1. First version