

Digital Fluxmeter

CYHT700SP

User's Manual

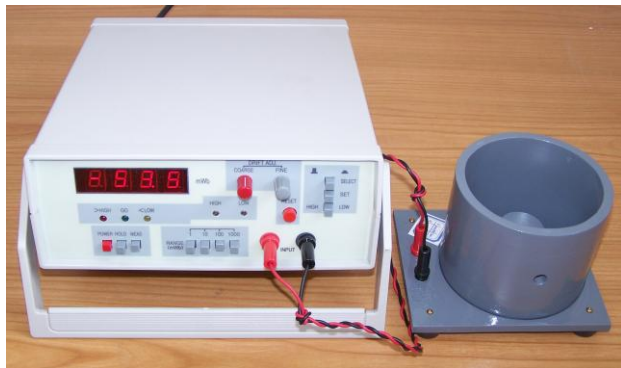

ChenYang Technologies GmbH & Co. KG

Markt Schwabener Str. 8
 85464 Finsing, Germany
 Tel. +49-(0)8121-2574100
 Fax: +49-(0)8121-2574101
 Email: info@chenyang-gmbh.com
<http://www.chenyang-gmbh.com>

1. Introduction

The Fluxmeter CYHT700SP is an electronic integrating, digital displayed instrument with high sensitivity and small drift. The Fluxmeter can be used not only for the measurement of the magnetic flux of permanent magnets, but also for quality control and sorting of magnetic products. Its versatility makes the employment possible in laboratory enterprise as also in production.

This Fluxmeter has the functions such as maximum value hold and automatic pole indication and 4 measuring ranges. It can be used also for measurement of impulse magnetic field

2. Technical Data

Range	Display Range	Effective Range	Resolution	Input resistance
1mwb	0~±1.999mwb	10 ⁻⁵ ~10 ⁻³ wb	0.001mwb	10kΩ
10mwb	0~±19.99mwb	10 ⁻⁴ ~10 ⁻² wb	0.01mwb	100kΩ
100mwb	0~±199.9mwb	10 ⁻³ ~10 ⁻¹ wb	0.1mwb	1MΩ
1000mwb	0~±1999mwb	10 ⁻² ~1wb	1mwb	10MΩ

Accuracy: ±1.0%
 Instability/drift: ±5 Digits/10s, ±10 Digits/min
 Display: 3 ½ LED, automatic polarity display
 Output signal: 0-2V DC analogue
 Functions: Maximum value hold, automatic polarity indication
Sorting: setup maximum & minimum limits
 Red LED: higher than maximum limit
 Yellow LED: lower than minimum limit
 Green LED: within the tolerance (PASS)

Ambient temperature: 5°C ~ 40°C
 Storage temperature: -25°C ~ +55°C
 Warm-up time: 30min
 Relative humidity: 20% ~ 80%
 Power supply: AC 220V, 50Hz
 Dimensions: 280mm x 240mm x 95mm
 Weight: 2.0kg

3. Accessories

- Helmholtz coil

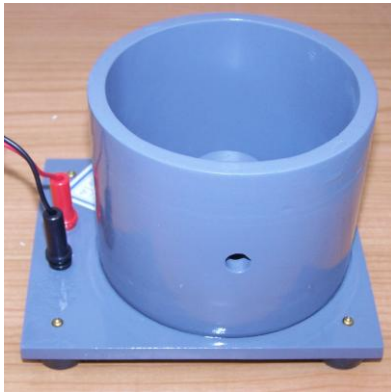

1 piece

Structure: Ø100 x 50mm

Dimension: Ø100 x 85mm
(Standard)

Note:

The outer diameter of measuring object should be smaller than Ø40mm

4. Special Coil

- Custom made coil (additional purchase order)



Custom made coil for segment/block magnets

(Additional purchase order is needed)

5. Measuring Principle

This series of Fluxmeter measures the flux Φ of a magnetic field by using the electromagnetic induction principle and electronic integration method. The diagram of the measuring system is shown in the following figure.

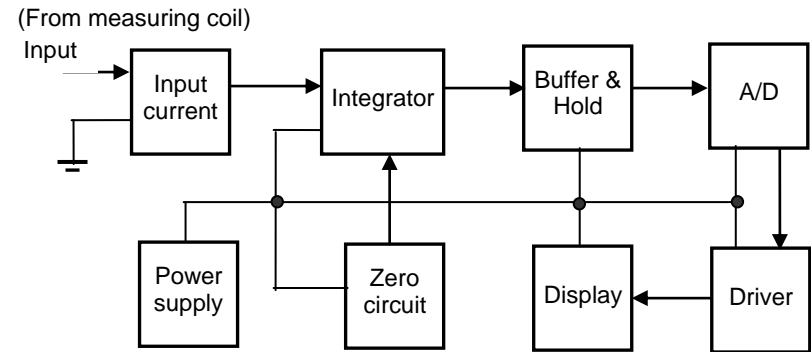

A current is induced by the change of magnetic flux Φ passing through a measuring coil. The current is the input of the fluxmeter. After the integration of the current one obtains a DC voltage signal, which is proportional to the change of the magnetic flux. The DC voltage is converted into digital signal and displayed by the LEDs. Thus the magnetic flux can be measured in this way.

According to the electromagnetic induction principle the magnetic flux Φ can be written as

$$\phi = B \cdot N \cdot S \quad (1)$$

Where:

- B: Magnetic flux density applied to measuring coil (Tesla)
- N: Windings of the measuring coil
- S: Sectioned area of the measuring coil (m²)

On the other hand the magnetic field can be determined by

$$B = \frac{\phi}{N \cdot S} \quad (2)$$

Therefore one can determined the magnetic field after measuring the magnetic flux passing through the measuring coil.

6. Parts and Functions

The power supply socket outlet (15) and the voltage output connector (16) are on the back panel of the fluxmeter. Connect the voltage output (0-2VDC) to multimeter or to A/D and computer if it is necessary.

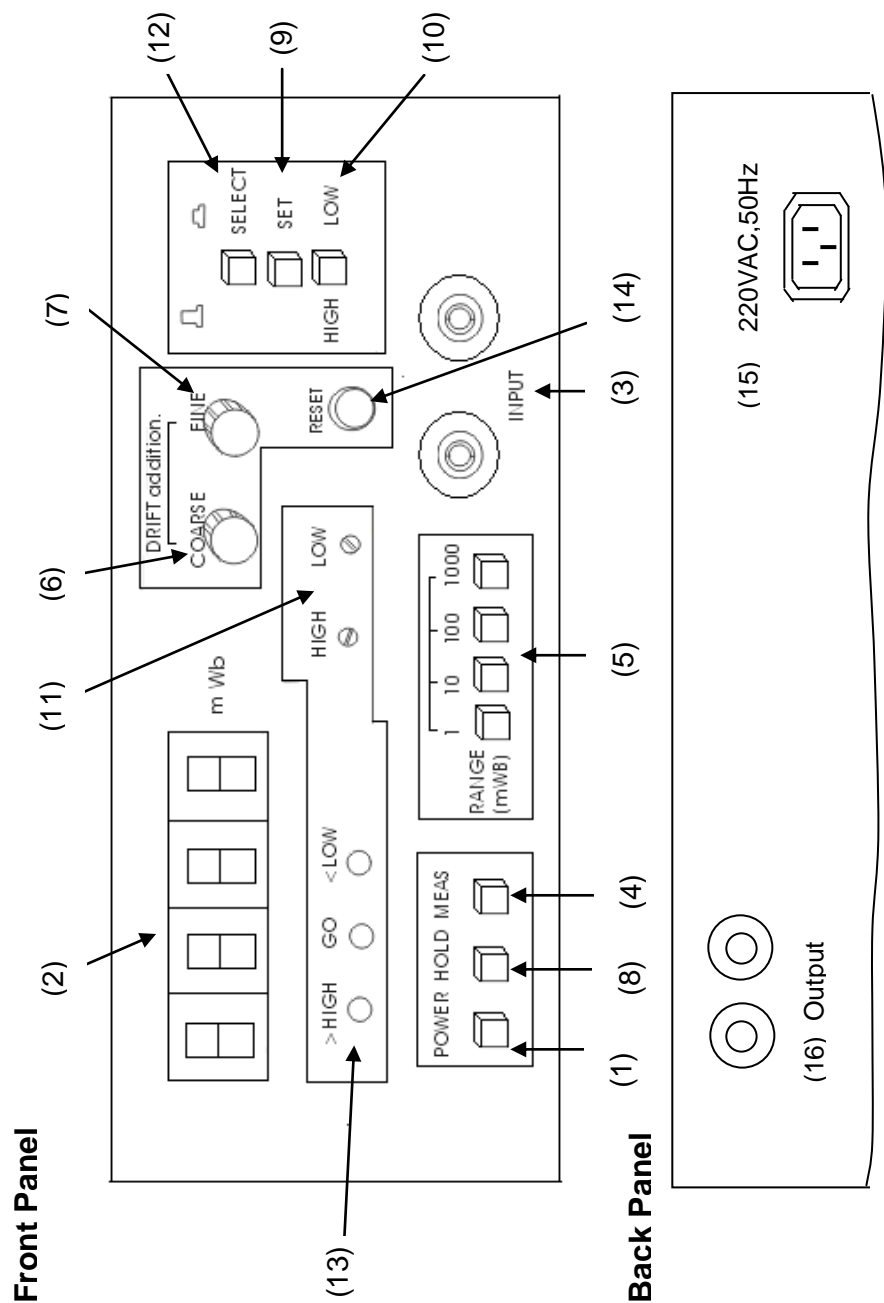

Parts:

- | | |
|--------------------------------|------------------------------|
| 1: Power Button | 2: LED display |
| 3: Input socket outlet | 4: Measuring button |
| 5: Measuring range | 6: Coarse adjustment |
| 7: Fine adjustment | 8: Peak value hold |
| 9: Sorting Setup | 10: High /Low Setting |
| 11: High /Low value adjustment | 12: Selection |
| 13: Classification LEDs | 14: RESET |
| 15: Power socket outlet | 16: Analogue voltage output. |

Functions:

- Power button:** to switch ON/OFF the fluxmeter
- LCD display:** to display the magnetic flux and pole direction (“+”: north pole, “-“: south pole).
- Input socket outlet:** to connect the measuring coil to the fluxmeter
- Measuring button:** press this button to measure the magnetic flux
- Measuring range:** to select the measuring range: 1mwb, 10mwb, 100mwb and 1000mwb
- Coarse adjustment:** to adjust the drift compensation coarsely
- Fine adjustment:** to adjust the drift compensation finely
- Peak value hold:** to display and hold the peak/max value
- Sorting setup:** to set the maximum and minimum value for sorting the measuring object
- High/Low setting:** Press this button to set the Low limit value; release the button to set the High limit value
- High/Low value adjustment:** to change the High/Maximum value and the Low/Minimum value
- Selection:** press this button to let the Fluxmeter to work in the selection mode
- Classification:** to indicate the selection result:
 HIGH: Measuring value > Maximum value
 Pass (GO): Minimum ≤ measuring value ≤ Maximum
 LOW: Measuring value < Minimum
- RESET:** reset the display to zero
- Power socket outlet:** to connect the power supply 220VAC, 50Hz
- Analogue voltage output:** to output an analogue voltage 0-2.0V DC

Range	Measuring Range	Output Range
1mwb	0~±1.999mwb	0 ~ ±2V
10mwb	0~±19.99mwb	0 ~ ±2V
100mwb	0~±199.9mwb	0 ~ ±2V
1000mwb	0~±1999mwb	0 ~ ±2V

7. Measuring Procedure

- 1) After connecting the power supply to the power socket outlet (15) of the fluxmeter press the button **POWER** (1) to switch ON the fluxmeter. The **LED** display (2) is on.
- 2) Connect the measuring coil (for instance Helmholtz Coil) to the **INPUT** (3) of the fluxmeter.
- 3) Press the button **MEAS** (4) and select a suitable measuring range such as "10", "100" and so on (Please select the highest range when the range is unpredictable.).
- 4) **Drift Adjustment:** after pressing the measuring button **MEAS** (4) the **LED** display (2) will show a random value. The displayed value will increase in one direction continuously. This value drift is caused by the accumulation of the signal drift of the integrator in the fluxmeter. The adjustment is in the right turning direction if the drift value changes slowly during adjusting the drift with the zero potentiometer **COARSE** (6). Otherwise, you should reverse the turning direction of the adjustment until the drift value changes considerable slowly. In this case one can also use the **FINE** (7) potentiometer to adjust the drift. Press the **RESET** (14) button after the drift value has been stable. The **LED** should display zero. If the display is still not to zero one should not stop the adjustment until the display is zero. The zero point will be more stable if you use the **FINE** (7) potentiometer to adjust the drift.
- 5) **Measurements:** after the drift adjustment you can start the measurement in the following ways:
 - (1) **Positive Measurement:** Press the **RESET** (14) and put the measuring object (e.g. permanent magnet) into the measuring coil. Please note the magnetization direction of measuring object should be the axial direction of measuring coil. The **LED** shows the measuring value of the flux of the measuring object. Please read and write down the measuring value immediately.

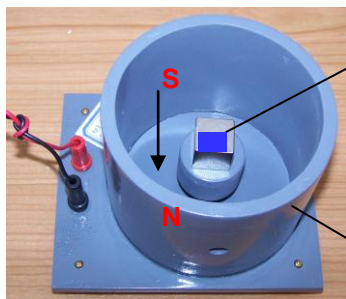

NdFeB Block Magnet
Magnetization direction
"+" : North Pole
"-": South Pole
Helmholtz Coil

The North Pole is on the bottom side of the measuring object if the display value without any symbol (in fact it is "+"). South Pole is on the bottom side if you get the minus value from the display.

- (2) **Negative Measurement:** Put the measuring object (e.g. permanent magnet) into the measuring coil and press the **RESET** (14) and then take the measuring object far away from the measuring coil and read /write down the display value immediately. This value is the measuring flux result of the measuring object with opposite symbol. You should reverse the symbol of the measuring value in order to get the right magnetic pole of the measuring object.
- (3) **Average Measurement:** In order to get the accurate measuring value you can use the positive measurement and negative measurement and then calculate the average of the two measuring results. The average value is considered as the measuring result. Here is the measuring procedure:
Press the **RESET** (14) and put the measuring object (e.g. permanent magnet) into the measuring coil. Read and write down the first measuring value immediately. Press the **RESET** (14) again and take the measuring object far away from the measuring coil and read /write down the second measuring value immediately.

Note: The value will be changed after a time period because of the electrical signal drift. Therefore the measurement should be finished in a few seconds. This means that you should read the measuring value immediately after taking the measuring object from the measuring coil.

- 6) **Peak Value Hold:** press **HOLD** (8) and **RESET** (14) and put the measuring object (e.g. permanent magnet) into the measuring coil. The maximum value will be displayed and hold even if the measuring object is removed from the measuring coil. Press **RESET** (14) before the next measurement in order to reset the maximum value.

Note: Drift adjustment is necessary under pressing **MEAS** (4) before measurement. In **HOLD** mode a drift adjustment is not possible.

7) Selection Function

Selection function is mainly used to online test the magnetic performance of products. After pre-setting up the maximum and minimum flux limits of the products, one will get three classifications: (1) lower than minimum limit **LOW** (yellow); (2) between the two limits **GO** (Pass, green); (3) higher than the

maximum limit **HIGH** (red). Using the result, the eligibility of the products can be distinguished.

The selection system is composed of functional switches, setup adjustment and classification display. The functional switches include **SELECT** (12), **HIGH/LOW** (10) and **SET** (9). After pressing **SELECT** (12), the instrument switches to the selection mode. By pressing **SET** (9), the instrument switches automatically to the setup status. Use the **HIGH/LOW** button to adjust the potentiometer to the maximum and minimum limits. Under the **SELECT** mode measurement and selection can be carried out simultaneously. When both **SELECT** (12) and **SET** (9) buttons are released, the instrument switches to the measurement mode.

Operation instruction

- (1) After pressing **SET** (9) set the **LOW/HIGH** (10) button at **HIGH** position and adjust **HIGH** potentiometer to make the display to the maximum limit MAX. "1000" indicates the full range (excluding the radix point)
- (2) Press **SET** (9) and set the **LOW/HIGH** (10) button at **LOW** position, and adjust **LOW** potentiometer to read the minimum limit MIN on the display.
Note: the maximum limit must be higher than the minimum limit. The minimum limit will change with the adjustment of the maximum limit while the maximum limit doesn't change with the adjustment of the minimum limit.
- (3) By pressing **SELECT** (12), the instrument switches to the selection mode. The **LOW** (yellow) LED will be on when the display is reset to zero because zero is lowest value.
- (4) The measurement can be taken only after the correct setting. Apart from the direct digital display of the measurement result X, the comparative result between the measurement result and the MAX/MIN limits will be displayed by the LEDs:
 - Red LED: $X > \text{MAX}$
 - Green LED: $\text{MIN} \leq X \leq \text{MAX}$ (product is eligible)
 - Yellow LED: $X < \text{MIN}$.
- (5) When the "SELECT" and "SET" buttons are released to the original status, the instrument exits from the selection mode, and all LEDs are switched off. The measurement mode and hold mode are available again.

8. Applications

The fluxmeter CYHT700SP can be used for measuring the inner flux of permanent magnets (block, disc/cylinder, ring and segment) with a Helmholtz coil or simple single coil.

8.1 Flux Measurement with Helmholtz Coil

Helmholtz Coil

Helmholtz coil refers to a device for producing a region of nearly uniform magnetic field. It consists of two identical circular magnetic coils that are placed symmetrically one on each side of the experimental area along a common axis, and separated by a distance h equal to the radius R of the coil. Each coil carries an equal electrical current flowing in the same direction.

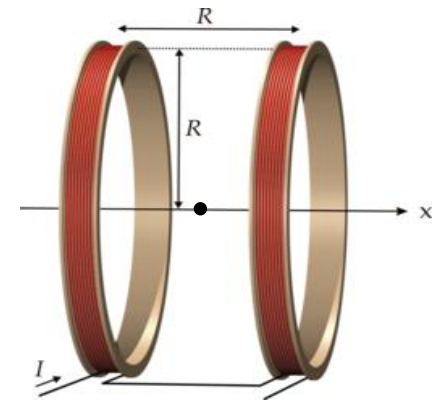

Reversely a current will be generated in the Helmholtz coil when a permanent magnet is placed in the center of the coil. The flux passing through the coil can be determined by measuring the current with the fluxmeter.

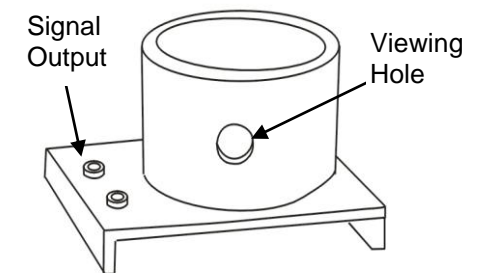

Measuring Procedure

Connect the signal output of the coil to the fluxmeter **INPUT** (3) and adjust the height of the measuring platform in the coil in order to be suitable for the measurement. The best position of the measuring object is determined by the center point of the measuring object. The center point should be at the center of the viewing hole of the coil.

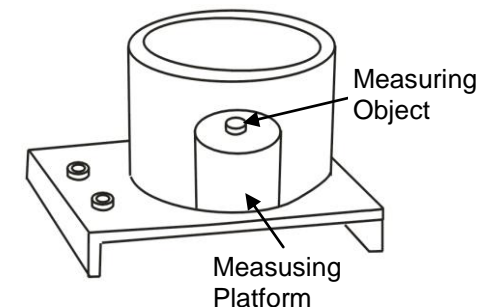

Put the measuring object on the measuring platform at the center of the coil. Measure the flux of the object according to the measuring methods mentioned above (see measurements in the section 7).

Calculation of Magnetic Flux Density B

The magnetic flux density B can be written as follows:

$$B = C \frac{\Phi}{V} \left(1 + \frac{R_c}{R_{in}}\right) \quad (3)$$

Where B: Magnetic flux density (in Gs)
 Φ : Magnetic flux, measured (in Maxwell)
 R_{in} : Input resistance of Fluxmeter
 C: Coil constant (in cm), R_c : Coil resistance
 V: Volume of the measuring object (in cm^3)
 1mwb = 100000 Maxwell = 10^5 Maxwell

Note: The inner diameter of the Helmholtz Coil should be at least 2.5 times of the outer diameter of measuring object.

Examples: Measurements of NdFeB Magnets (material grade N38)

Magnet	Size (mm)	Coil constant C	Flux Φ (mwb)	B (Gs)
Block	20x20x20	0.01294cm	76.4	12357.7
Disc	$\varnothing 12 \times 10$	0.01294cm	11.2	12821.0
Ring	$\varnothing 20 \times \varnothing 8 \times 5$	0.01294cm	12.0	11774.0

8.2 Flux Measurement of Segment/Block Magnets

The magnetic flux of segment or block magnets can be measured with a special coil shown below.

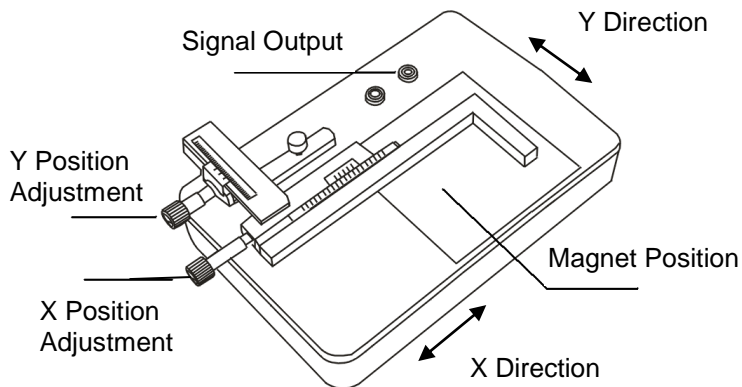

Adjust the X and Y position of magnet by using the X and Y adjustment knobs. The scale value in X direction should be equal to the half of the width of the magnet and scale value in Y direction equal to the half of length of the magnet.

Place the segment magnet to the magnet position. One vertex angle of the magnet should be connected to the right angle of X direction scale.

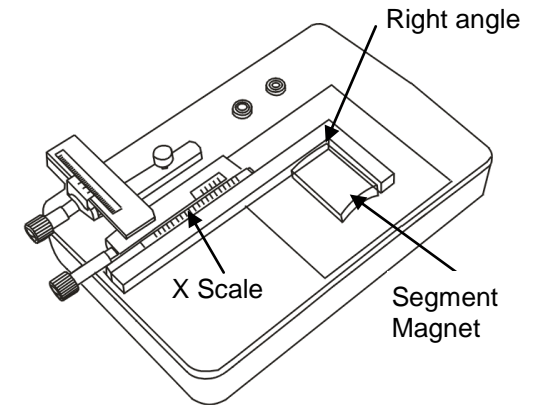

Measure the flux of the object according to the measuring methods mentioned above (see measurements in the section 7).

9. Warranty

Measuring instrument: 12 months after shipment
 Helmholtz coil: 12 months after shipment

10. Service

Please contact us for technical questions, repairing and replacement etc:

ChenYang Technologies GmbH & Co. KG
 Markt Schwabener Str. 8
 85464 Finsing, Germany
 Tel. +49-(0)8121-2574100
 Fax: +49-(0)8121-2574101
 Email: info@chenyang-gmbh.com
 http://www.chenyang-gmbh.com