



STC-TGL2M

User's Manual



Toll Free Customer Support 1-888-304-6125

www.wildviewcam.com

Version 1.3

08/06

STC-TGL2M

**For Customer Service or Warranty Information Call
Toll Free**

888-304-6125

WILDVIEW

P.O. Box 535189

Grand Prairie, Texas 75053-5189

www.wildviewcam.com

Wildview Scouting Camera Limited Warranty

Your Wildview Scouting Camera is covered by a One Year Limited Warranty on parts & labor from the date of purchase.

The warranty covers defects in workmanship & materials.

The warranty does not apply to units, which have been damaged or abused intentionally or unintentionally.

Tampering with or altering the unit will void the warranty. Any unauthorized service will void warranty. Original sales receipt must be produced for any warranty service.

Questions call 888-304-6125.

www.wildviewcam.com

Toll Free 888-304-6125

Manual Contents

Camera overview	4
Camera kit contents	7
Battery and memory Installation	8
Definition	11
Programming	13
Mounting the camera	16
Viewing images	20
Saving and Deleting images	23
Memory compatibility chart	26
Technical Specs	27
General Information	30

Camera overview

Front view

Side view

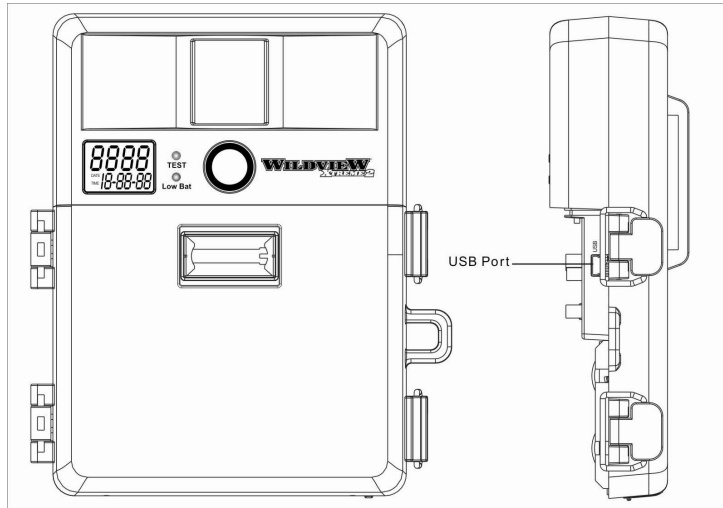

STC-TGL2M

Open view image with major parts indication

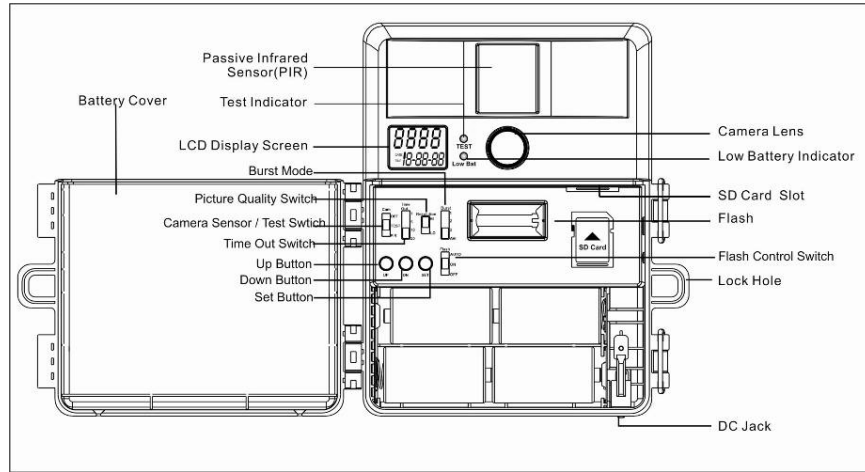

STC-TGL2M

Picture / Image Capacity

SD card	High 2.0M 1600 x 1200	Low 1.3M 1280 x 1024	AVI QVGA 320 x 240
Built In SDRAM	8	12	2
16MB	26	40	8
32MB	52	80	16
64MB	104	160	32
128MB	208	320	64
256MB	416	640	128
512MB	832	1280	256

NOTE: Picture / Image Capacity Chart provides approximate number of images or AVI movies based on resolution setting and the size of memory card. These figures may vary depending on the amount of detail in the image.

Camera kit contents

- Model STC-TGL2M Digital Scouting Camera
- Camera driver
- User Manual
- 1.5M USB cable
- Strap

Battery & memory installation

Warning: Do not use different Voltage lead acid battery other than the one specified in this section. Doing so will damage the camera and will void the warranty.

The Wildview STC-TGL2M Digital Scouting Camera is designed to operate using alkaline batteries for optimum performance.

NOTE: Always have camera in OFF position when installing or removing batteries.

Batteries “C” cell

The internal battery compartment accepts 4 “C” cell batteries. Be sure to use high quality brand name alkaline batteries. Install batteries in correct polarity (+/-) as noted inside battery compartment.

12V Lead Acid external battery

The STC-TGL2M is equipped with an external power jack designed to accept a barrel plug cable to attach to a sealed lead acid battery. (sold separately). Battery cable and complete 12V Lead Acid battery kits are available wherever Wildview scouting cameras are sold or call toll free 888-304-6125. Only Wildview external battery accessories are recommended.

- Insert the battery pack plug into the DC 12V jack at the bottom of camera housing
- Turn on the camera by sliding the power switch to PIR position

Please make sure the voltage and polarity (+/-) are correct before connection. Incorrect voltage or polarity (+/-) will damage the camera.

Memory Options

Your Wildview scouting camera is equipped with 16MB built in SDRAM memory. The camera is also equipped with an expandable media card slot capable accepting up to 512MB SD card (sold separately). With no memory

STC-TGL2M

card inserted into the slot, the camera will use the built in 16MB SDRAM memory. If a SD card is inserted into the slot then the camera will bypass the built in memory and utilize the SD memory. The front counter display will show the number of images on the built in memory unless the expansion card is inserted at which point the counter will only show the number of images in the expansion card.

Inserting SD card

Make sure camera is in the OFF position whenever adding or removing memory.

- Insert SD memory card in to the SD card slot completely and in the correct direction as shown on the inside of the housing.
- To remove the SD memory card, depress the SD card and pull out the card gently.
- ❖ ***SD cards must be clean (no images from other sources.)***

Definition

- **Time out:** To set the amount of preset time in minutes the camera will sleep between PIR triggering
- **Resolution:** The resolution selection that you have selected.
 - **High:** Select this option to capture a 2.0M pixel image quality
 - **Low:** Select this option to capture a 1.3M pixel image quality
- **Date/Time:** To set date and time stamp in the picture
- **Flash:** Auto / On / Off mode

STC-TGL2M

- **Burst:** To set number of picture the camera will take per PIR triggering
 - 1P: Single image capturing per PIR triggering
 - 2P: Two images continuous capturing per PIR triggering
 - 3P: Three images continuous capturing per PIR triggering
 - AVI: 10 seconds video clip per PIR triggering
- **FULL:** When memory capacity is full, this front LCD screen will show "FULL"

Programming

The following setting must be performed before you turn on the camera.

1. Select the time out interval by sliding the time out toggle switch to the desire preset time interval in minutes. **1 / 5 / 10 / 20 minutes.**
2. Select the resolution setting by sliding the resolution toggle switch to the desire resolution setting. **Hi / Lo resolution.**
3. Select the Flash mode: Slide the switch to either **Auto / On / Off** position.
 - a. Auto – Flash on based on surround lighting condition
 - b. On – Flash on for every image captured
 - c. Off – No Flash will go off.
4. Select Frame mode: Slide the switch to 1 / 2 / 3 / AVI position. If you choose AVI mode, the camera will automatically switch to 1 picture mode if it detect low light source.

STC-TGL2M

5. Turn on the Camera to set the Date / Time stamp
 - a. Slide the power switch to PIR position
 - b. Press and hold [SET] button for 2 seconds to enter date & time setting mode.
 - c. Time and HH will blink. Press [UP] or [DN] to adjust hour
 - d. Press [SET] button to enter minute setting. Time and MM will blink. Press [UP] or [DN] to adjust minute.
 - e. Press [SET] button to enter month setting. Date & MM will blink. Press [UP] or [DN] to adjust month.
 - f. Press [SET] button to enter date setting. Date & DD will blink. Press [UP] or [DN] to adjust date.
 - g. Press [SET] button to enter year setting. Date & YY will blink. Press [UP] or [DN] to adjust year.

STC-TGL2M

- h. Press and hold [SET] button for 2 seconds to exit the setting mode and into PIR count down mode. Display will show date and number of picture taken.

Once the program setting has been completed, slide the power switch to OFF position until you are ready for field use.

NOTE: Date & Time setting will be lost whenever battery is removed from camera. Don't forget to re-set the Date & Time stamp after you replace the battery.

Mounting the camera

It is recommended to mount the camera 4-5 ft off the ground with the camera pointed at a slight downward angle. Be sure to avoid mounting the camera facing east or west as the rising and setting of the sun could produce false triggers and overexposed images. Clear branches and other debris away from the front of the camera so as not to block the camera lens or PIR sensor.

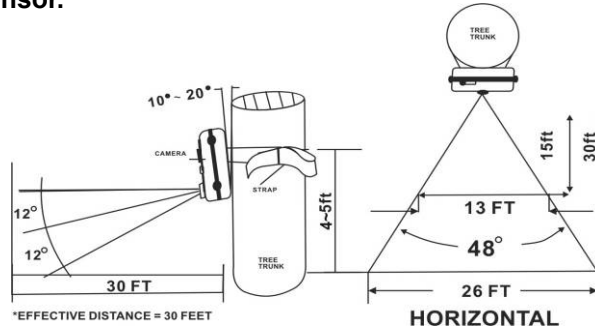

PIR Coverage Area Diagram

STC-TGL2M

Mounting the camera with the supplied strap

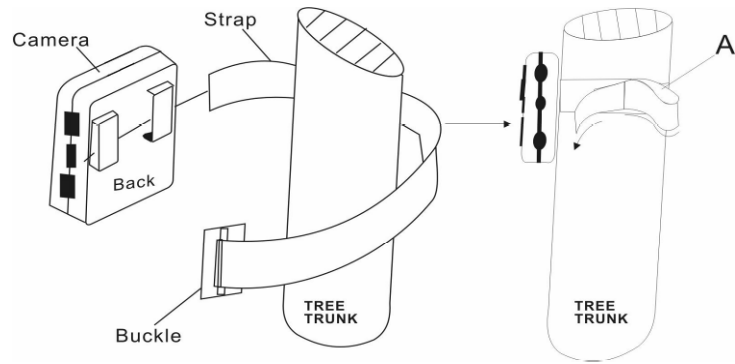

- Insert the strap through the strap slots on the rear housing.
- Wrap the strap around the mounting surface. Secure the strap and tighten the buckle in order to secure the camera.

- ❖ ***In order to obtain proper weather resistance, please make sure that both door latches are securely locked in place.***

Testing the camera coverage area

One of Wildview Scouting Camera's features is the ability to test the coverage area.

- After mounting the camera, open front housing and slide the power switch to Test position. The front LCD will display the word "tEst".
- Close the front housing.
- Walk around in the front of the camera to see if you have mounted camera in the proper position. A green indicator light on the front will blink on when you have intruded the coverage area.
- Adjust the camera position as needed and repeat testing until the desired coverage area is achieved.

STC-TGL2M

- When you have completed the testing the coverage area open the front housing and slide the power switch from Test position to PIR position. Front LCD counter will show "0000". The camera will enter count down mode for 1 minute and front green indicator will start blinking giving you one minute to leave the coverage area. Then camera will enter PIR detection mode.

NOTE: Make sure you slide the power switch from TEST mode to PIR mode before you leave the field. Otherwise the Camera will not take any pictures.

Switch use: Do not move the switch from TEST directly to PIR. Doing so will cause the camera to not operate. Slide the switch to OFF. Wait for the front LCD screen to turn off then continue to slide the switch to PIR.

Viewing images

Viewing images by computer download

The Wildview Scouting Camera is a plug and play USB storage device. This means users of Windows 2000 / ME / and XP operating system need not install the camera driver. This camera is not MAC compatible. The CD-ROM included in this package contains the camera driver for older operating system only.

Attention

The software CD-ROM packaged with the camera is designed for PC's only (not MAC compatible). Playing this CD-ROM on a stereo or CD player may cause damage to it.

Driver installation

- Unplug the USB cable from PC.
- Insert the CDRom in CD driver of your PC.
- The auto-run program will execute.

STC-TGL2M

- Follow the instructions shown on screen from your PC to completely install the driver and application program.
- If the existing DirectX version on your PC is lower than version 8, and if you have problem viewing the image with the standard software provided by Microsoft, then you should install DirectX 8
- Restart windows.
- Turn off the camera
- Connect your camera to the PC by the USB cable, the PC will recognize the new device and set up the configuration of the PC automatically. Front LCD on your camera will show the word "USb".

NOTE: Users of Windows 98 must install camera driver prior to connecting the USB cable.

STC-TGL2M

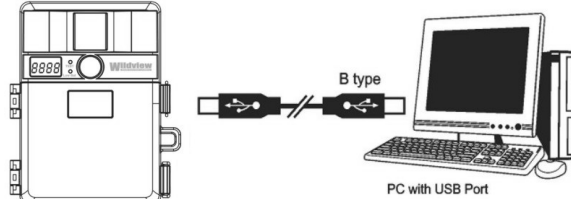

- If your computer doesn't run automatically, please click "Start" button and choose "Run", and then browse the CD drive and click "Setup".

Viewing the images on your computer

- Slide the power switch to OFF location.
- To view the images simply plug one end of the USB cable into an available USB port on your computer.
- Plug the other end of USB cable into the camera. The camera will automatically power ON. Front LCD screen will show "USb"
- At the same time, your computer will recognize the camera as mass storage device and found under MY COMPUTER.

Saving and Deleting images

SAVING IMAGES

To save images on to your PC, simply copy and paste, or drag and drop from the SDRAM memory to your PC desk top.

DELETING IMAGES

There are two ways to delete the images from the internal SDRAM memory.

1. After you download image into your desk top, you can delete the image in the SDRAM: Unplug the USB Cable from camera. Slide the power switch to PIR position. LCD screen will display the number of images captured in the memory.
 - o Delete One picture:
 - a. Press [SET] button to enter delete setting. Display will show "ESC"
 - b. Press [UP] or [DN] to select d-ONE (delete one)
 - c. Press [SET] to delete the image. Press [UP]

STC-TGL2M

or [DN] until screen shows "ESC" then press [SET] again to exit.

- d. This will only delete the last image saved in the memory.
- Delete All picture:
 - a. Press [SET] button to enter delete setting. Display will show "ESC"
 - b. Press [UP] or [DN] to select d-ALL (delete all)
 - c. Press [SET] to delete all images and display will show "DONE" and exit to count down mode automatically.
- Format:
 - a. Press [SET] button to enter delete setting. Display will show "ESC"
 - b. Press [UP] or [DN] to select Ft (format)
 - c. Press [SET] to confirm and display will show "DONE" and exit to count down mode automatically.

STC-TGL2M

- ESC: To exit delete setting.
2. Simply remove the battery from the battery compartment. This will delete the image stored in the internal SDRAM memory

CAUTION:

Do not remove the battery until you have down loaded all the images in the internal SDRAM. Once the battery is removed, all images in the internal SDRAM will be deleted. (This does not apply to images stored in SD card)

RED LED indicator will blink when battery is low. Turn off the camera. Down load the pictures immediately. DO NOT attempt to replace the batteries before you save the images in your PC. Once the battery is drained completely, or if you attempt to replace the battery, all images in the internal SDRAM memory will be lost.

SD Compatibility Chart

The following cards have been tested and approved for use in the Wildview STC-TGL2M model.

PQI	32MB, 64MB, 128MB, 256MB, 512MB
San Disk	32MB, 64MB, 128MB
Panasonic	32MB, 64MB, 128MB,
Toshiba	32MB, 64MB, 128MB, 256MB, 512MB
King Mate	32MB, 64MB, 128MB, 256MB, 512MB
Lexar	512MB
Kingston	128MB, 256MB, 512MB
Kodak	128MB, 256MB, 512MB
Dan-Elec	128MB, 256MB, 512MB
Viking	128MB
PNY	128MB, 256MB, 512MB

Proper camera operation cannot be guarantee when using memory card **NOT** listed above.

Technical Specifications

System Requirements and Compatibility

- Windows 98/98se/2000/Me/XP.
- Pentium III 450MHz or equivalent processor.
- 128MB SDRAM or above.
- VGA Video Card with 32MB RAM for minimum, Color 16 bit or higher.
- An available CDROM driver and an available USB Port.
- 600 MB free hard disc space.
- ❖ ***If you have any questions regarding your PC specifications please call your PC manufacturer.***

Camera Features and Specification.

- Image sensor: 1.3 mega-pixels (2.0 mega-pixels interpolation)
- Built in 16MB SDRAM memories for image storage.
- External memory support: SD memory card up to 512MB.
- Resolution Options: 2.0M / 1.3M / QVGA (Video)
- Auto white balance and auto expose.
- Auto/On/Off Flash light strobe control
- 4 digits LCD Image counter
- Battery low indicator
- Green Test LED indicator
- Focusing: 5 ft to Infinity
- 4 P glass lens with IR coating
- Effective viewing Angle: 52 deg

STC-TGL2M

- PIR detection angle 48 deg
- Low power consumption:
 - Standby current: < 4mA
 - Capture current <120mA
- Interface type: USB 1.0
- Power: C size alkaline Batteries x 4.
- Image format: Standard JPEG. And Motion JPEG (AVI)

General Information

Storing conditions

- Operating Environment: 14 to 104 deg F (-10 to 40 deg C). 20-85% relative humidity, non-condensation.

Special care instructions!!

- The camera is designed to be weather resistant. Never attempt to immerse the unit to water or any other liquid. This will damage the unit and void the warranty.
- Use a soft lens cloth for cleaning lens. Avoid touching lens with fingers.
- Remove dirt or stains with a soft cloth dampened with water or neutral detergent. Keep the Wildview scouting camera in a dry and cool dust-free environment or container when it is NOT used.
- Take the batteries out, when the Wildview scouting camera is NOT to be used over a long period.

STC-TGL2M

- Avoid dropping the Wildview scouting camera on to hard ground. Do not disassemble the Wildview scouting camera.
- Do not mix new and old batteries.
- Do not open the camera for unauthorized service. This could cause serious damage to the unit and will void the warranty.

This camera is a precision electronic device. Do not attempt to service this camera yourself, as opening or removing covers may expose you to dangerous voltage points or other risks.

Caution: When camera is switched off, if there is any residual power left in the camera, it will take an extra picture to discharge the left over power in the camera. Under low lighting condition, the flash will go off.

WF043A_R2 Print in China

www.wildviewcam.com

Toll Free 888-304-6125

31