



PowerLogic®

Circuit Monitor

Series 2000

Installation and Operation



NOTICE

Read these instructions carefully and look at the equipment to become familiar with the device before trying to install, operate, or maintain it. The following special messages may appear throughout this bulletin to warn of potential hazards or to call attention to information that clarifies or simplifies a procedure.

DANGER

Used where there is hazard of serious injury or death. Failure to follow a "DANGER" instruction *will* result in death or serious injury.

WARNING

Used where there is hazard of serious injury or death. Failure to follow a "WARNING" instruction *can* result in death or serious injury.

CAUTION

Used where there is hazard of equipment damage. Failure to follow a "CAUTION" instruction can result in damage to equipment.

Note: Provides additional information to clarify or simplify a procedure.

PLEASE NOTE: Electrical equipment should be serviced only by qualified electrical maintenance personnel, and this document should not be viewed as sufficient for those who are not otherwise qualified to operate, service, or maintain the equipment discussed. Although reasonable care has been taken to provide accurate and authoritative information in this document, no responsibility is assumed by Square D for any consequences arising out of the use of this material.

FCC NOTICE: This equipment complies with the requirements in Part 15 of FCC rules for a Class A computing device. Operation of this equipment in a residential area may cause unacceptable interference to radio and TV reception, requiring the operator to take whatever steps are necessary to correct the interference.

TECHNICAL SUPPORT

For technical support, contact the Power Management Operation Technical Support Center. Hours are 7:30 A.M. to 4:30 P.M., Central Time, Monday through Friday.

Phone: (615) 287-3400

Fax: (615) 287-3404

BBS: (615) 287-3414

Email: PMOSUPRT@SquareD.com

POWERLOGIC, SY/MAX, SY/NET, SY/LINK, POWER-ZONE, VISI-VAC, ISO-FLEX and  are Registered Trademarks of Square D Company. SYSTEM MANAGER and CIRCUIT TRACKER are Trademarks of Square D Company.

Windows, Windows NT, and Windows 95 are Registered Trademarks of Microsoft Corporation. Other names are trademarks or service marks of their respective companies.

Please fill out, detach, and mail the postage paid card below. Fill out only one registration card, even if you have purchased multiple POWERLOGIC devices.

Registration Card

Register your POWERLOGIC OR POWERLINK product today and get:

- Free expert technical phone support—just call (615) 287-3400
- Notice of product upgrades and new product releases
- Notice of special product offers and price discounts

Name _____ Dept./Title _____

Company _____

Mailing Address _____

City _____ State _____ Country _____

Zip/Postal Code _____ Email Address _____

Telephone _____ Fax _____

Product Purchased Through (Distributor) _____

Please tell us how many of each of the following products you have:

Circuit Monitors: 1-5 6-20 21-50 51-100 100+

Power Meters: 1-5 6-20 21-50 51-100 100+

Are you interested in receiving information on POWERLOGIC Application Software?

Yes No



NO POSTAGE
NECESSARY
IF MAILED
IN THE
UNITED STATES

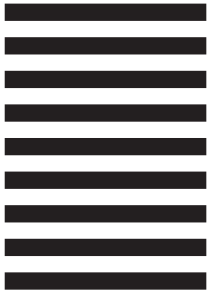

BUSINESS REPLY MAIL

FIRST CLASS MAIL PERMIT NO. 635 PALATINE, IL

POSTAGE WILL BE PAID BY ADDRESSEE

SQUARE D COMPANY
295 TECH PARK DR STE 100
LA VERGNE, TN 37086-9908



CONTENTS

CHAPTER 1—INTRODUCTION 1

- What is the Circuit Monitor? 1
- Expanded Memory 3
 - Requirements for Using 4
 - Identifying the Series and Firmware Revisions 4
 - Model Numbers 4
 - Upgrading Existing Circuit Monitors 5
 - Memory Options Summary 5
- Safety Precautions 6
- Using This Bulletin 6
 - Notational Conventions 6
 - Topics Not Covered Here 7
- Related Documents 7
 - Fax-On-Demand 7
 - Reference Manual 8

CHAPTER 2—HARDWARE DESCRIPTION 9

- Front Panel 9
- Rear Connections 11

CHAPTER 3—INSTALLATION 13

- CE Compliance 14
- Mounting the Circuit Monitor 15
- Wiring CTs, PTs, and Control Power 17
 - Wiring Multiple Circuit Monitors to a Single Set of PTs/CPT 25
 - Deriving Control Power from Phase PT Inputs 26
- Grounding the Circuit Monitor 27
- Communications Wiring 28
 - Connecting to a System Display 29
 - Connecting to a Personal Computer 30
 - Connecting to a POWERLOGIC Ethernet Gateway 31
 - Connecting to a POWERLOGIC Network Interface Module 32
 - Connecting to a SY/MAX Programmable Controller 33
 - Length of the Communications Link 34
 - Daisy-Chaining POWERLOGIC Devices 35
 - Terminating the Communications Link 36
 - Biasing the Communications Link 37

CHAPTER 4—FRONT PANEL OPERATION 39

- The Setup Mode 40
 - The Configuration Option 40
 - The Resets Option 40
 - The Alarm/Relay Option 40
 - The Diagnostics Option 40
 - Choosing a Setup Option 41

How the Buttons Work	41
Configuring the Circuit Monitor	42
Factory Defaults	42
General Configuration Procedure	42
Viewing Configuration Data in Protected Mode	45
Setting the Master Password	46
Configuring the Circuit Monitor (cont.)	
Setting the CT Ratios	47
Setting the PT Ratio	48
Setting the System Type	48
Setting the Demand Interval	49
Setting the Watthour/Pulse Output	51
Setting the Device Address	52
Setting the Baud Rate	53
Setting the Nominal Frequency	54
Resetting Demand, Energy, and Min/Max Values	55
Performing Resets Using the Resets Option	56
Setting Up Alarm/Relay Functions	58
General Setup Procedure	59
Detailed Setup Procedure	60
Viewing Active Alarms	63
Viewing the Priority 1 Log	64
Clearing the Priority 1 Log	65
CHAPTER 5—MAINTENANCE AND TROUBLESHOOTING	67
Maintenance	67
Battery-Backed RAM	67
Troubleshooting	68
Getting Technical Support	69
APPENDICES	
Appendix A—Circuit Monitor Dimensions	71
Appendix B—Specifications	73
Appendix C—Installing Terminal Strip Covers	75
FIGURES	
2-1 Circuit monitor front panel	10
2-2 Back of the circuit monitor	11
3-1 Example of disconnect breaker for CE compliance	14
3-2 Panel preparation	16
3-3 Circuit monitor mounted in electrical panel	16
3-4 3-phase, 3-wire delta connection	18
3-5 3-phase, 4-wire wye, ground connection	19
3-6 3-phase, 4-wire wye, ground connection, metered neutral	20
3-7 3-phase, 4-wire wye, 3-wire load	21
3-8 2-1/2 element metering system type 42 (calculated neutral)	22

3-9 2-1/2 element metering system type 43 23

3-10 DC control power connections 24

3-11 Circuit monitors connected to one set of PTs and one CPT 25

3-12 Deriving L-L control power from phase PT inputs 27

3-13 Deriving L-N control power from phase PT inputs 27

3-14 Grounding the circuit monitor 28

3-15 Circuit monitors connected to a system display for circuit monitors 29

3-16 POWERLOGIC devices connected directly to a personal computer 30

3-17 POWERLOGIC devices connected to an Ethernet gateway 31

3-18 POWERLOGIC devices connected to a PNIM 32

3-19 POWERLOGIC devices connected to a SY/MAX programmable controller 33

3-20 Daisy-chaining the RS-485 communications terminals 35

3-21 Terminator placement when last device on the link is a circuit monitor 36

3-22 Multipoint communications adapter connected to PNIM 37

4-1 Choosing a Setup option 41

4-2 Flowchart for front panel configuration 44

4-3 Flowchart for performing resets using the Resets option 57

4-4 Alarm/Relay setup 59

A-1 Circuit monitor dimensions 71

A-2 Circuit monitor dimensions with Input/Output and Voltage/Power Modules 72

A-3 Circuit monitor with Input/Output Module 72

C-1 Installing terminal strip covers 75

TABLES

1-1 Summary of circuit monitor instrumentation 3

1-2 Class 3020 circuit monitors 3

1-3 Circuit monitor feature comparison 3

3-1 Typical circuit monitor mounting locations 15

3-2 Supported system wiring connections 17

3-3 Maximum distances of comms link at different baud rates 34

4-1 Factory defaults for front panel configuration parameters 42

4-2 Supported system type system code selections 48

4-3 Maximum distances of comms link at varying baud rates 53

CHAPTER 1—INTRODUCTION

CHAPTER CONTENTS

This chapter offers a general description of the circuit monitor, describes important safety precautions, tells how to best use this bulletin, and lists related documents. Topics are discussed in the following order:

What is the Circuit Monitor?	1
Expanded Memory	3
Requirements for Using	4
Identifying the Series and Firmware Revisions	4
Model Numbers	4
Upgrading Existing Circuit Monitors	5
Memory Options Summary	5
Safety Precautions	6
Using This Bulletin	6
Notational Conventions	6
Topics Not Covered Here	7
Related Documents	7
Fax-On-Demand	7
Reference Manual	8

Note: This edition of the circuit monitor instruction bulletin describes features available in series G4 or later and firmware version 17.009 (or higher). Series 2000 circuit monitors with older series numbers or firmware versions will not include all features described in this instruction bulletin. If you have Series 2000 circuit monitors that do not have the latest firmware version and you want to upgrade their firmware, contact your local Square D representative for information on purchasing the Class 3020 Type CM-2000U Circuit Monitor Firmware Upgrade Kit.

WHAT IS THE CIRCUIT MONITOR?

The POWERLOGIC® Circuit Monitor is a multifunction, digital instrumentation, data acquisition and control device. It can replace a variety of meters, relays, transducers and other components. The circuit monitor is equipped with RS-485 communications for integration into any power monitoring and control system. However, POWERLOGIC System Manager application software—written specifically for power monitoring and control—best supports the circuit monitor’s advanced features.

The circuit monitor is a true rms meter capable of exceptionally accurate measurement of highly nonlinear loads. A sophisticated sampling technique enables accurate, true rms measurement through the 31st harmonic. Over 50 metered values plus extensive minimum and maximum data can be viewed from the six-digit LED display. Table 1-1 on page 3 provides a summary of circuit monitor instrumentation.

The circuit monitor is available in several models to meet a broad range of power monitoring and control applications. Table 1-2 on page 3 lists the circuit monitor models. Table 1-3 compares the features available by model.

Circuit monitor capabilities can be expanded using add-on modules that mount on the back of the circuit monitor. A voltage/power module and several input/output modules are available. See **I/O Capabilities** in the *Circuit Monitor Reference Manual* for a description of the available I/O modules.

**What is the Circuit Monitor?
(cont.)**

Using POWERLOGIC application software, users can upgrade circuit monitor firmware through either the RS-485 or front panel optical communications ports. This feature can be used to keep all circuit monitors up to date with the latest system enhancements.

Some of the circuit monitor's many features include:

- True rms metering (31st harmonic)
- Accepts standard CT and PT inputs
- Certified ANSI C12.16 revenue accuracy
- High accuracy—0.2% current and voltage
- Over 50 displayed meter values
- Min/Max displays for metered data
- Power quality readings—THD, K-factor, crest factor
- Real time harmonic magnitudes and angles
- Current and voltage sag/swell detection and recording
- On-board clock/calendar
- Easy front panel setup (password protected)
- RS-485 communications standard
- Front panel, RS-232 optical communications port standard
- Modular, field-installable analog and digital I/O
- 1 ms time stamping of status inputs for sequence-of-events recording
- I/O modules support programmable KYZ pulse output
- Setpoint-controlled alarm/relay functions
- On-board event and data logging
- Waveform and event captures, user-selectable for 4, 12, 36, 48, or 60 cycles
- 64 and 128 point/cycle waveform captures
- High-speed, triggered event capture
- Programming language for application specific solutions
- Downloadable firmware
- System connections
 - 3-phase, 3-wire Delta
 - 3-phase, 4-wire Wye
 - Metered or calculated neutral
 - Other metering connections
- Optional voltage/power module for direct connection to 480Y/277V
- Optional control power module for connecting to 18–60 Vdc control power
- Wide operating temperature range standard (-25 to +70°C)
- UL Listed, CSA certified, and CE marked
- MV-90™ billing compatible
- Pre-configured data log and alarms

Table 1-1
Summary of Circuit Monitor Instrumentation

Real-Time Readings	Energy Readings
<ul style="list-style-type: none"> • Current (per phase, N, G, 3Ø) • Voltage (L-L, L-N) • Real Power (per phase, 3Ø) • Reactive Power (per phase, 3Ø) • Apparent Power (per phase, 3Ø) • Power Factor (per phase, 3Ø) • Frequency • Temperature (internal ambient)* • THD (current and voltage) • K-Factor (per phase) 	<ul style="list-style-type: none"> • Accumulated Energy, Real • Accumulated Energy, Reactive • Accumulated Energy, Apparent* • Bidirectional Readings*
	Power Analysis Values*
	<ul style="list-style-type: none"> • Crest Factor (per phase) • K-Factor Demand (per phase) • Displacement Power Factor (per phase, 3Ø) • Fundamental Voltages (per phase) • Fundamental Currents (per phase) • Fundamental Real Power (per phase) • Fundamental Reactive Power (per phase) • Harmonic Power • Unbalance (current and voltage) • Phase Rotation • Harmonic Magnitudes & Angles (per phase)
Demand Readings	
<ul style="list-style-type: none"> • Demand Current (per-phase present, peak) • Demand Voltage (per-phase present, peak)* • Average Power Factor (3Ø total)* • Demand Real Power (3Ø total) • Demand Reactive Power (3Ø total)* • Demand Apparent Power (3Ø total) • Coincident Readings* • Predicted Demands* 	
	* Available via communications only.

Table 1-2
Class 3020 Circuit Monitors

Type	Description
CM-2050	Instrumentation, 1% accuracy
CM-2150	Instrumentation, 0.2% accuracy, data logging, alarm/relay functions
CM-2250	Waveform capture, plus CM-2150 features
CM-2350	Instrumentation, waveform capture, 0.2% accuracy
CM-2450	Programmable for custom applications, plus-2350 features

Table 1-3
Circuit Monitor Feature Comparison

Feature	CM-2050	CM-2150	CM-2250	CM-2350	CM-2450
Full Instrumentation	X	X	X	X	X
RS-485 Comm Port	X	X	X	X	X
Front Panel Optical Comm Port	X	X	X	X	X
1% Accuracy Class	X				
0.2% Accuracy Class		X	X	X	X
Alarm/Relay Functions		X	X	X	X
On-board Data Logging		X	X	X	X
Downloadable Firmware		X	X	X	X
Date/Time for Each Min/Max		X	X	X	X
Waveform Capture			X	X	X
Extended Event Capture			X	X	X
Extended Memory (up to 1.1 Meg.)*		X	X	X	X
Sag/Swell Detection				X	X
Programmable for Custom Applications					X

* Standard memory: CM-2150, CM-2250, CM-2350, and CM-2450 = 100K; CM-2452 = 356K

EXPANDED MEMORY

New Series G4 (or higher) circuit monitor models CM-2150 and higher now are factory-equipped with 100 kilobytes (100K) of nonvolatile memory. (Earlier Series G3 models CM-2150 and CM-2250 shipped with 11K of memory, models CM-2350 and CM-2450 with 100K of memory.)

EXPANDED MEMORY (cont.) For applications where additional memory is required, you can order a circuit monitor with an optional 512K or 1024K memory expansion card, resulting in 612K or 1124K, respectively, total nonvolatile memory (100K base memory plus the expansion card memory). Memory upgrade kits are also available for most earlier circuit monitors. See **Upgrading Existing Circuit Monitors**, page 5.

Requirements for Using Expanded Memory

System Manager software version 3.02 with Service Update 1, 3.02a with Service Update 1, or 3.1 (or higher) is required to take advantage of expansion card memory or the 100K of memory standard on G4 circuit monitors. Earlier versions of System Manager software will recognize only 11K (the Series G3 and earlier memory capacity) of available memory.

Also, your circuit monitor must be equipped with firmware version 17.008 or later to take advantage of expanded memory. The following section tells how to determine the firmware version shipped with your circuit monitor.

To determine if your circuit monitor firmware version has been updated with downloadable firmware, see **Viewing Configuration Data in Protected Mode**, page 45.

To obtain the latest available firmware revision contact your local Square D representative (see *Note*, page 1.)

Identifying the Series and Firmware Revisions

The circuit monitor series and firmware revision number are printed on a sticker on the top of the circuit monitor enclosure. Figure 1-1 shows a sample sticker.



Figure 1-1: Circuit monitor series/firmware revision sticker

Model Numbers

Circuit monitor models equipped with an optional memory expansion card are differentiated from standard models by a suffix—either -512k or -1024k—added to the model number (table 1-4). As shown in the table, the memory expansion option is available for model numbers CM-2150, CM-2250, CM-2350, and CM-2450. The CM-2452 circuit monitor is now obsolete and has been replaced by the CM-2450-512k, which has more memory at a lower price than the CM-2452. However, existing CM-2452 circuit monitors can be upgraded as detailed on the following page.

**Table 1-4
 Circuit Monitor Model Numbers**

Standard Models	Models with 512k Option	Models with 1024k Option
3020 CM-2050	N/A	N/A
3020 CM-2150	3020 CM-2150-512k	3020 CM-2150-1024k
3020 CM-2250	3020 CM-2250-512k	3020 CM-2250-1024k
3020 CM-2350	3020 CM-2350-512k	3020 CM-2350-1024k
3020 CM-2450	3020 CM-2450-512k	3020 CM-2450-1024k

Upgrading Existing Circuit Monitors

Memory upgrade kits are available for field installation by a qualified electrician. No special tools are required.

DANGER

HAZARD OF ELECTRIC SHOCK, BURN, OR EXPLOSION

Only qualified electrical workers should install a memory upgrade kit in a circuit monitor. Perform the upgrade only after reading the installation instructions shipped with the upgrade kit. Before removing the cover of the circuit monitor to install the memory board:

- Disconnect all voltage inputs to the circuit monitor
- Short the CT secondaries
- De-energize the control power inputs

Failure to observe this precaution will result in death or serious injury.

For Series G3 and earlier circuit monitors, the memory upgrade kit can be installed only in circuit monitor models CM-2350 and CM-2450.

Note: Model CM-2452 was factory-equipped with 100K of memory and a 256K memory expansion card, for a total of 356K of memory. The 256K card can be removed and replaced with a 512K or 1024K expansion card, for total memory of either 612K or 1124K.

The memory upgrade kit can be installed in Series G4 models CM-2150 and higher. Memory upgrade kits are available with either the 512k or 1024k memory card (see table 1-5). No special tools are required for installation.

Table 1-5
Memory Upgrade Kit Part Numbers

Part Number	Description
3020 CM-MEM-512K	512K Memory Upgrade Kit for Series 2000 Circuit Monitors
3020 CM-MEM-1024K	1024K Memory Upgrade Kit for Series 2000 Circuit Monitors

Memory Options Summary

Table 1-6 summarizes the memory options now available for Series 2000 Circuit Monitors. To obtain price and availability on circuit monitors with expanded memory and circuit monitor memory upgrade kits, contact your local sales representative.

Table 1-6
Series 2000 Circuit Monitor Memory Options

Model Number	Total Memory Capacity					
	Series G3 or Earlier			Series G4 or Later		
	Standard	512K Expansion	1024K Expansion	Standard	512K Expansion	1024K Expansion
CM-2050	N/A	N/A	N/A	N/A	N/A	N/A
CM-2150	11K	N/A	N/A	100K	612K	1124K
CM-2250	11K	N/A	N/A	100K	612K	1124K
CM-2350	100K	612K	1124K	100K	612K	1124K
CM-2450	100K	612K	1124K	100K	612K	1124K
CM-2452	356K	612K ①	1124K ①	Obsolete		

① CM-2452 256K memory expansion card removed and replaced with 512K or 1024K memory expansion card.

SAFETY PRECAUTIONS

DANGER

HAZARD OF BODILY INJURY OR EQUIPMENT DAMAGE

- Only qualified electrical workers should install this equipment. Such work should be performed only after reading this entire set of instructions.
- The successful operation of this equipment depends upon proper handling, installation, and operation. Neglecting fundamental installation requirements may lead to personal injury as well as damage to electrical equipment or other property.
- Before performing visual inspections, tests, or maintenance on this equipment, disconnect all sources of electric power. Assume that all circuits are live until they have been completely de-energized, tested, grounded, and tagged. Pay particular attention to the design of the power system. Consider all sources of power, including the possibility of backfeeding.

Failure to observe this precaution will result in death, serious injury or equipment damage.

USING THIS BULLETIN

This document provides the information required to install and operate the circuit monitor. The document consists of a table of contents, five chapters, and three appendices. Chapters longer than a few pages begin with a chapter table of contents. To locate information on a specific topic, refer to the table of contents at the beginning of the document, or the table of contents at the beginning of a specific chapter.

Notational Conventions

This document uses the following notational conventions:

- **Procedures.** Each procedure begins with an italicized statement of the task, followed by a numbered list of steps. Procedures require you to take action.
- **Bullets.** Bulleted lists, such as this one, provide information but not procedural steps. They do not require you to take action.
- **Cross-References.** Cross-references to other sections in the document appear in boldface. Example: see **Mounting the Circuit Monitor** in **Chapter 3**.

Topics Not Covered Here

Some of the circuit monitor's advanced features, such as on-board data log and event log files, must be set up over the communications link using POWERLOGIC application software. This circuit monitor instruction bulletin describes these advanced features, but does not tell how to set them up. For instructions on setting up these advanced features, refer to the appropriate application software instruction bulletin listed below.

Computer Operating System	Software	Instruction Bulletin Order No.
Windows NT®	SMS-3000 System Administrator's Guide (client/server)	3080IM9602
Windows NT®	SMS-3000 User's Manual (client/server)	3080IM9601
Windows NT/Windows® 95	System Manager Standalone (SMS-1500/PMX-1500/SMS-121)	3080IM9702
Windows 3.1	SMS-770/700	3080IM9305
Windows 3.1	EXP-550/500	3080IM9501
DOS	PSW-101	3080IM9302

See **Related Documents** in this section for information on obtaining instruction bulletins.

RELATED DOCUMENTS

Several optional add-on modules are available for use with the circuit monitor. Each module is shipped with an instruction bulletin detailing installation and use of the product. Available add-on modules for the circuit monitor are listed below.

Instruction Bulletin Title	Reference No. ^①
• POWERLOGIC Control Power Module (CPM-48)	3090IM9305
• POWERLOGIC Ride-Through Module	3090IM9701
• I/O Modules (IOM-11/44/18)	3020IM9304
• I/O Modules (IOM-4411/4444)	3020IM9401
• Voltage/Power Module	3090IM9302
• Optical Communications Interface (OCI-2000)	3090IM9303
• Ethernet Communications Module (ECM-2000/ECM-RM)	3020IB9818

Fax-On-Demand

In addition, the software and add-on module instruction bulletins listed in this chapter are available through D-Fax, the Square D fax-on-demand system. Phone 1-800-557-4556^② and request a POWERLOGIC/Power Monitoring index. Then call back and order the document(s) you want by specifying the Fax Document Number(s) from the index. The document(s) will be faxed to your fax machine. This service is accessible seven days a week, 24 hours a day.

^① Reference numbers listed are the original document numbers. If a document has been revised, the listed number will be followed by a revision number, for example R10/97.

^② In some instances, this toll-free number may not work if dialed from outside of the United States. In such instances, phone 1-919-217-6344 to speak to the D-Fax administrator.

Reference Manual

This Installation and Operation manual provides the information necessary to install and operate the circuit monitor. Additional information on the circuit monitor's advanced features is available in English only in the *POWERLOGIC Circuit Monitor Reference Manual*. The reference manual includes information on the following topics:

- Metering Capabilities
- Input/Output Capabilities
- Alarm Functions
- Logging
- Waveform Capture
- Disturbance Monitoring
- CM-2450 with Programming Language
- Advance Topics
- Communication Cable Pinouts
- Abbreviated Register Listing
- Calculating Log File Sizes
- Alarm Setup Information
- Reading and Writing Registers from the Front Panel

There are two ways to obtain the reference manual:

- Download an electronic version (Acrobat PDF format) from the POWERLOGIC web site at www.powerlogic.com.
- Order a printed copy from the Square D Literature Center at 1-800-888-2448. Ask for document #3020IM9806.

CHAPTER 2—HARDWARE DESCRIPTION

FRONT PANEL

The circuit monitor front panel is designed for maximum ease of use. The circuit monitor has five modes of operation:

- METERS — for viewing real-time metered data
- MIN — for viewing the minimum of the selected metered value
- MAX — for viewing the maximum of the selected metered value
- ALARM — for viewing the status of on-board alarms
- [Setup] — for setting up the circuit monitor

The general procedure for displaying data is simple:

1. Press the MODE button to select one of the five available modes.
2. Press the SELECT METER buttons to select a metered value.
3. Press the PHASE button to select a phase.

In [Setup] mode, use the alternate descriptions in grey to the right of the LEDs. In SETUP mode, the PHASE, MODE, and SELECT METER buttons function differently than in the other display modes. For details see **Chapter 4—Front Panel Operation**.

Figure 2-1 shows the front panel of the circuit monitor. A description of the front panel follows.

- ① **6-Digit LED display.** For local display of metered values.
- ② **Kilo/Mega LEDs.** The Kilo LED lights when the displayed value is in Kilo units. The Mega LED lights when the displayed value is in Mega units.
- ③ **Meter Indication LEDs.** The lit LED indicates the value being displayed.
- ④ **Setup/Reset Parameters.** These grey, bracketed values are used to set up the circuit monitor and perform resets. Refer to these values when in [Setup] mode.
- ⑤ **Phase Indication LEDs.** Indicate the phase for the displayed value.
Note: If you select a metered value that does not provide a reading for the selected phase, the circuit monitor automatically jumps to a phase for which a reading exists. For example, assume that you are viewing Phase A Power Factor, then change to Frequency; the circuit monitor automatically jumps from Phase A to 3-Phase, since the circuit monitor does not provide a Phase A Frequency reading.
- ⑥ **PHASE Select Button.** Press to select the phase for the selected meter value. **Note:** In [Setup] mode, press this button to move from one setup parameter to the next. See **Chapter 4—Front Panel Operation** for details.
- ⑦ **SELECT METER buttons.** Press to change the metered value being displayed. **Note:** In [Setup] mode, press these buttons to change the value of the displayed setup parameter. See **Chapter 4—Front Panel Operation** for details.

- ⑧ **Mode Indication LEDs.** These LEDs indicate the present display mode. The Alarm LED flashes when an alarm is active.
- ⑨ **MODE Select Button.** Press to select the display mode.
- ⑩ **Optical Communications Port.** This port allows the circuit monitor to communicate to a portable computer using the optional optical communications interface (Class 3090 Type OCI-2000). The OCI-2000 mounts magnetically to the circuit monitor and provides a standard RS-232 interface. Anything that can be done over the RS-485 communications link—including circuit monitor setup—can also be done using the optical communications port.

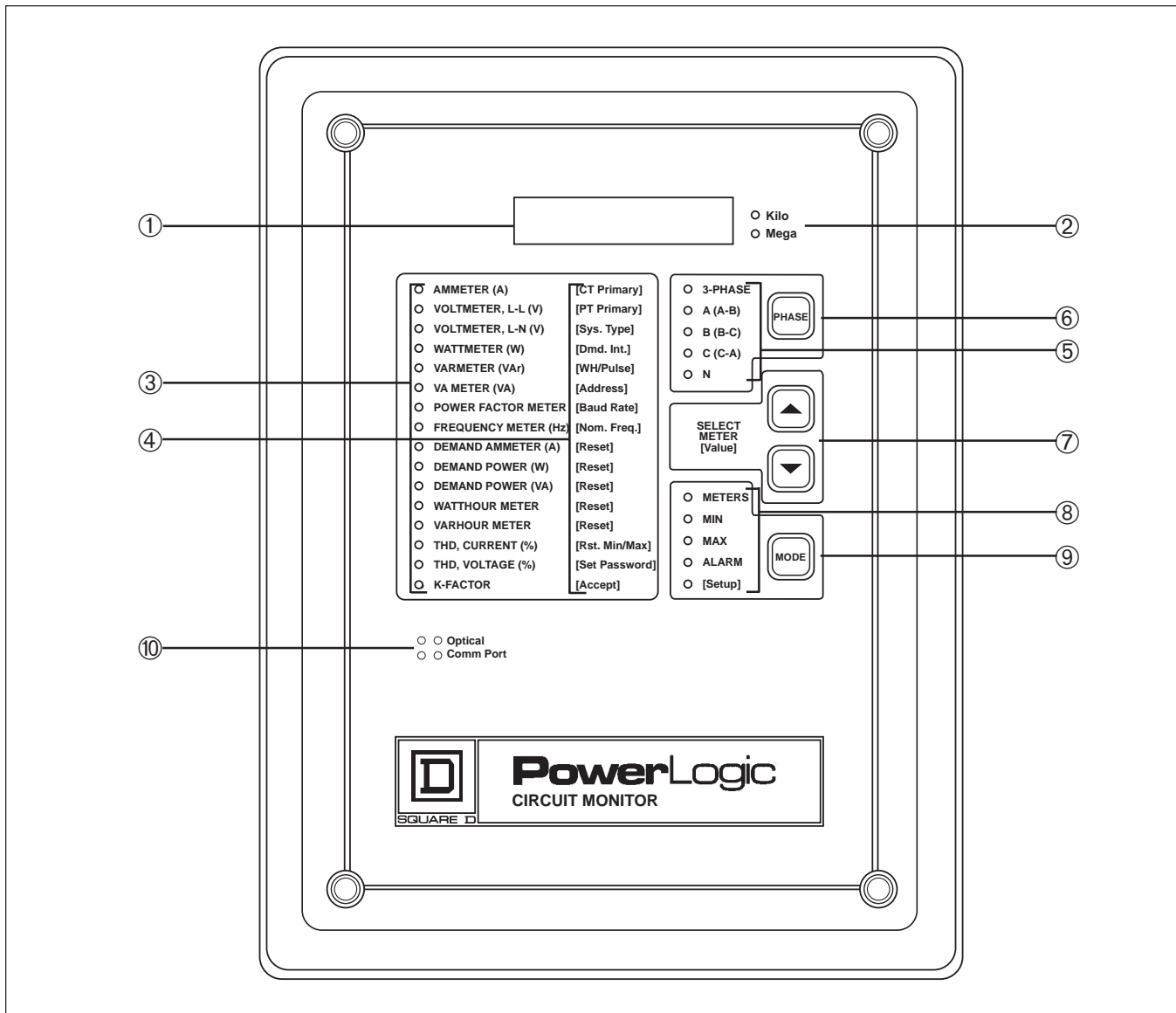

Figure 2-1: Circuit monitor front panel

REAR CONNECTIONS

Figure 2-2 shows the rear of the circuit monitor. Identified parts are as follows:

- ① Auxiliary Current Inputs
- ② 3-Phase Current Inputs
- ③ 3-Phase Voltage Inputs
- ④ RS-485 Communications Terminals
- ⑤ Input/Output Module Connector
- ⑥ Control Power Terminals

Note: See Chapter 3—Installation for wiring instructions.

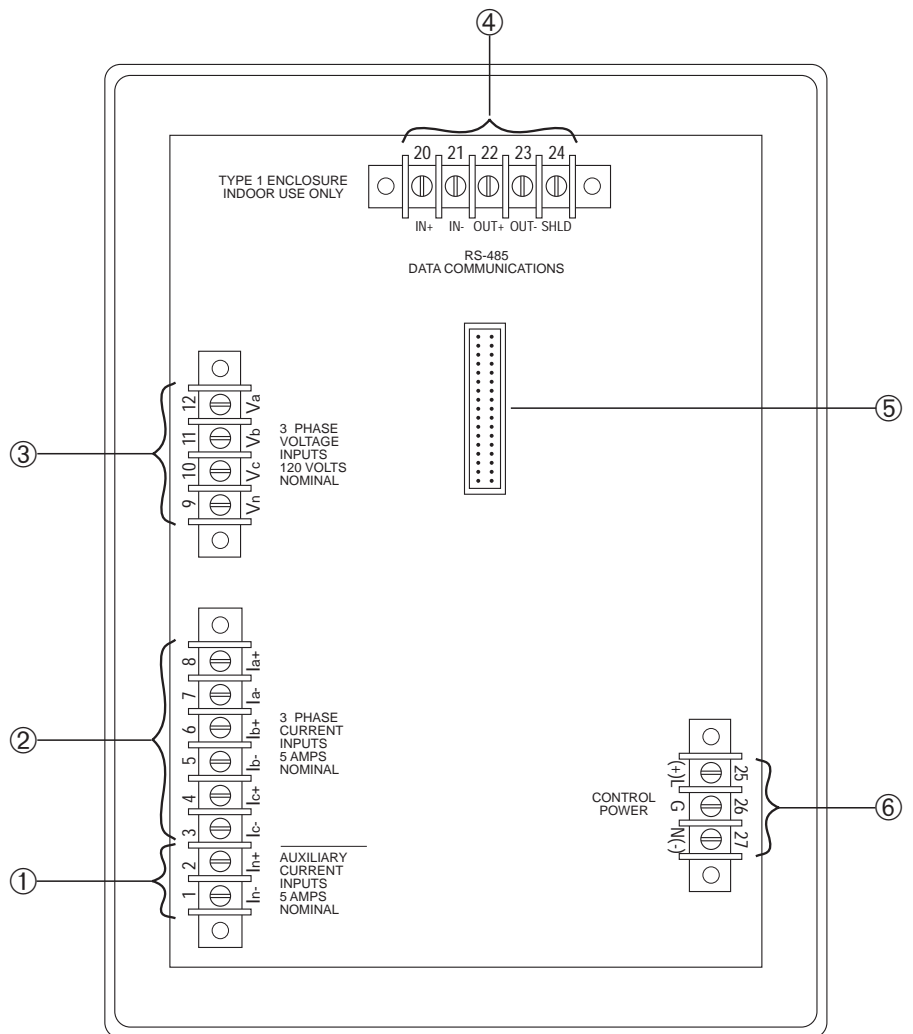



Figure 2-2: Back of the circuit monitor

CHAPTER 3—INSTALLATION

CHAPTER CONTENTS

This chapter tells how to mount and wire the circuit monitor. Refer to the table of contents below to locate a specific topic.

- CE Compliance 14
- Mounting the Circuit Monitor 15
- Wiring CTs, PTs, and Control Power 17
 - Wiring Multiple Circuit Monitors to a Single Set of PTs/CPT 25
 - Deriving Control Power from Phase PT Inputs 26
- Grounding the Circuit Monitor 27
- Communications Wiring 28
 - Connecting to a System Display 29
 - Connecting to a Personal Computer 30
 - Connecting to a POWERLOGIC Ethernet Gateway 31
 - Connecting to a POWERLOGIC Network Interface Module 32
 - Connecting to a SY/MAX[®] Programmable Controller 33
 - Length of the Communications Link 34
 - Daisy-Chaining POWERLOGIC Devices 35
 - Terminating the Communications Link 36
 - Biasing the Communications Link 37

DANGER

HAZARD OF PERSONAL INJURY OR DEATH

Only qualified electrical workers should install and wire this equipment. Such work should be performed only after reading this complete set of instructions.

Failure to observe this precaution will result in death, serious injury or equipment damage.

CE COMPLIANCE

To comply with CE Electromagnetic Compatibility requirements, the circuit monitor must be installed in a metallic enclosure (switchgear, for example).

For CE compliance, Merlin Gerin Disconnect Breakers Type P25M #21104 or IEC 947 equivalent must be connected directly to the metering voltage and control power inputs (figure 3-1).

Note: The disconnect switch must be placed within reach of the circuit monitor and labeled "Disconnect Switch for Circuit Monitor."

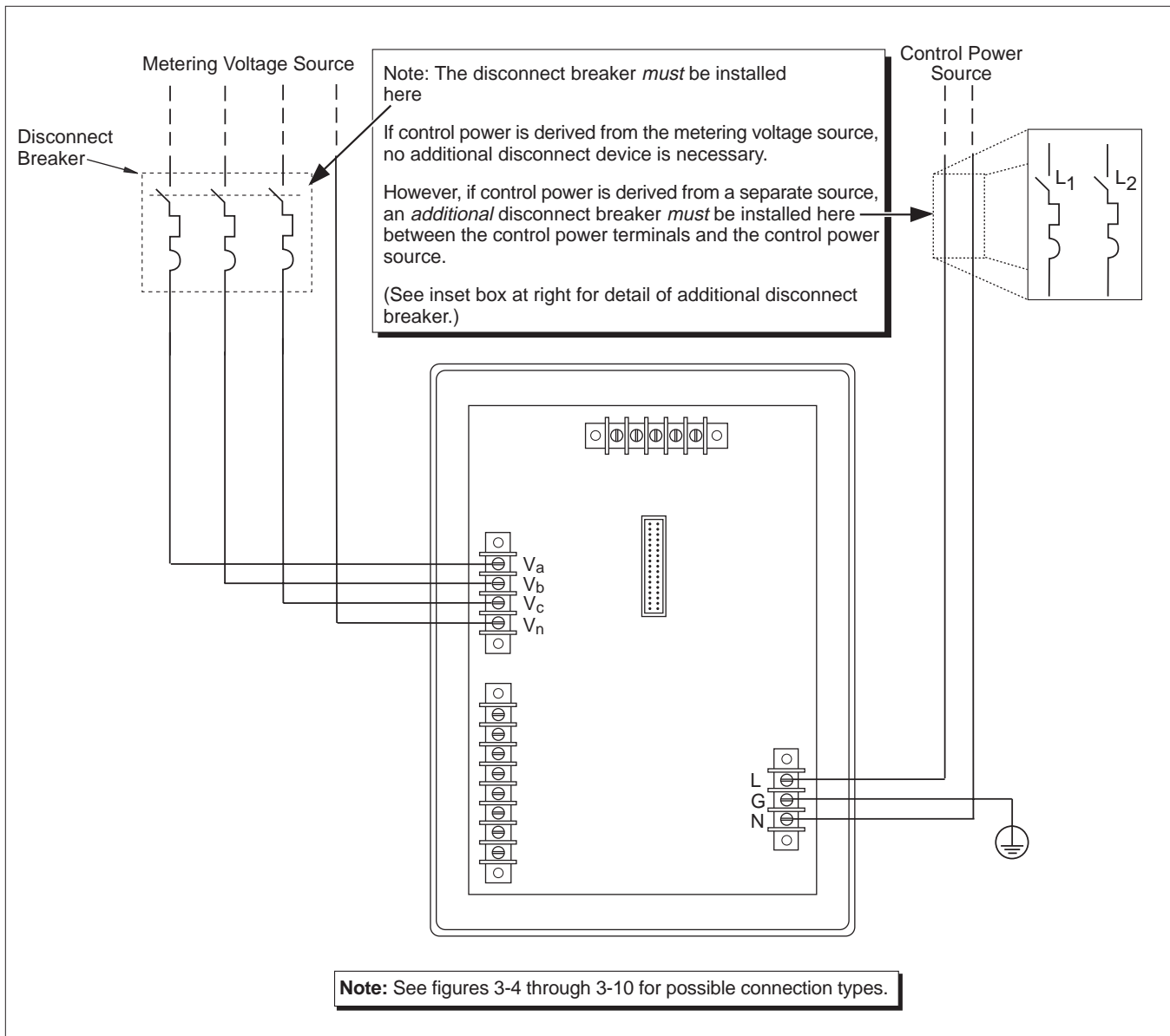

Figure 3-1: Example of disconnect breaker for CE compliance

MOUNTING THE CIRCUIT MONITOR

The circuit monitor is a flush-mounted device that projects through the back of a panel or breaker cell door. Table 3-1 lists typical mounting locations in various power equipment designs.

Note: Series 2000 circuit monitors use the same cutout dimensions and hole patterns as the Series 100, 200 circuit monitors, but the required rear clearances have increased.

When choosing a mounting location, consider the following points:

- Allow for easy access to the rear of the circuit monitor.
- Allow extra space for all wires, shorting blocks, or other components.
- Consider the depth of the circuit monitor. Include extra depth for add-on modules that you might add in the future. See **Appendix A** for circuit monitor dimensions.
- Be sure that ambient conditions fall within the acceptable range: operating temperature -25°C to $+70^{\circ}\text{C}$, relative humidity, 5–95% non-condensing.

For CE mounting requirements, see **CE Compliance**, page 14.

*Note: Before preparing the cutout, refer to **Appendix A** and verify that the required clearances exist.*

To mount the circuit monitor, complete the following steps:

1. Prepare the cutout and mounting holes. Refer to figure 3-2 for exact dimensions.
2. Insert the circuit monitor through the cutout from the front of the panel or breaker cell door. Guide the circuit monitor mounting studs through the holes in the panel.
3. Secure the circuit monitor to the panel using four #10-32 hex nuts included in the circuit monitor hardware kit (63230-204-16). Figure 3-3 shows the circuit monitor mounted in an electrical panel.

Table 3-1
Typical Circuit Monitor Mounting Locations

Equipment Type	Mounting Location
QED Switchboards, Model 6 MCCs	Main Meter Location or Aux. Section
POWER-ZONE® III Switchgear	Main Instrument Compartment Door
HVL and VISI/VAC® Switchgear	9-inch Front Panel or Instrument Door
Metal-Clad and Substation CBs	Standard Relaying Locations
ISO-FLEX® Medium Voltage MCCs	Standard Relaying Locations

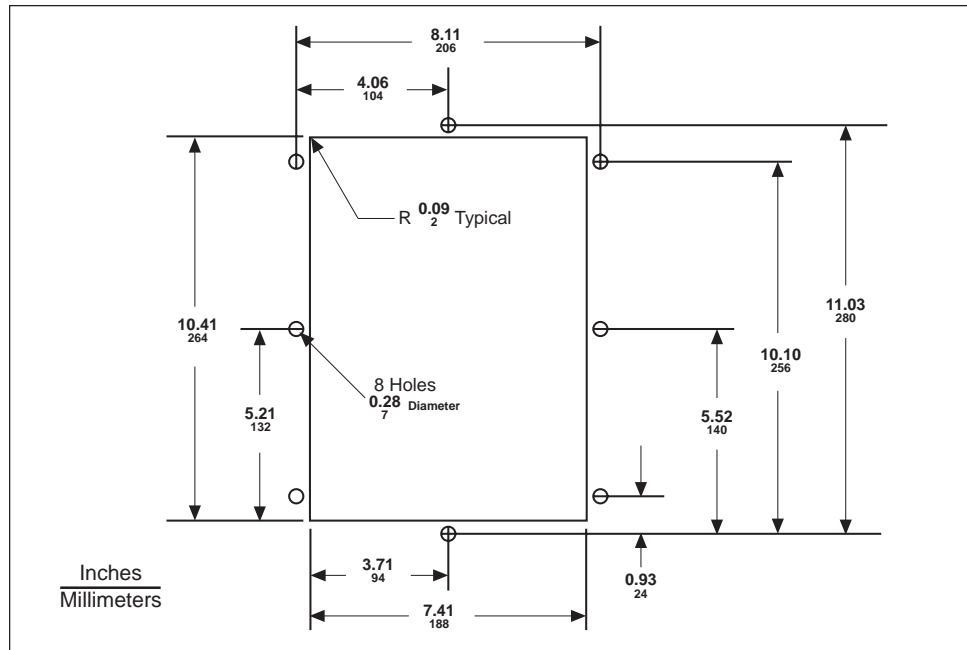

Figure 3-2: Panel preparation

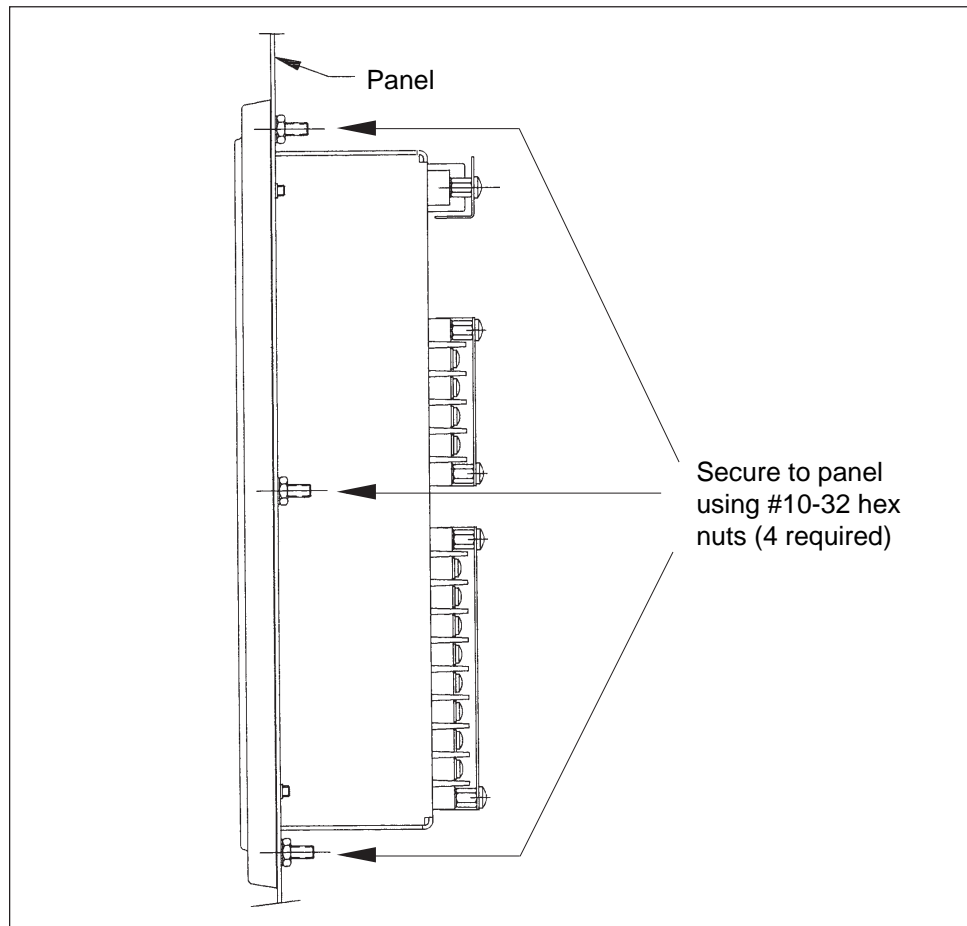

Figure 3-3: Circuit monitor mounted in electrical panel

WIRING CTs, PTs, AND CONTROL POWER

The circuit monitor supports a variety of 3-phase power system wiring connections, including 3-wire delta, and 4-wire wye. Table 3-2 lists the supported system connections. Figures 3-4 through 3-9 show CT, PT, and control power wiring. Figure 3-10 on page 24 shows dc control power.

Notes:

- When wiring the circuit monitor, route wires outward to make room for add-on modules that you might install in the future.
- Wiring instructions are also included in CM hardware kit.
- For CE wiring requirements, see **CE Compliance**, page 14.

To wire the circuit monitor, complete the following steps:

1. Using a suitable crimping tool, crimp the blue spade connectors included with the circuit monitor onto the wires for the voltage, current, and control power inputs.
2. Connect the spade connectors to the circuit monitor terminals as shown in the appropriate wiring diagram. (Figures 3-4 through 3-10 show wiring connections.) Do not overtighten screws, but ensure that they are snug.
3. Ground the circuit monitor. See **Grounding the Circuit Monitor** in this chapter for instructions.
4. Install protective terminal strip covers. See **Appendix C** for instructions.

DANGER

HAZARD OF PERSONAL INJURY OR DEATH

Only qualified electrical workers should install and wire this equipment. Such work should be performed only after reading this complete set of instructions. Follow proper safety procedures regarding CT secondary wiring. Never open circuit the secondary of a CT.

Failure to observe this precaution will result in death, serious injury or equipment damage.

Table 3-2
Supported System Wiring Connections

System Type	Sys ID ^①	# CTs	Aux. CT	# PTs	PT Conn.	Currents	Voltages	Figure #
3 \emptyset , 3-wire Delta	30	2	None	2	Open Delta	A, B ^② , C	A-B, B-C, C-A ^②	3-4
3 \emptyset , 4-wire Wye, Ground	40	3	None	3	Wye-Wye	A, B, C, N ^②	A-N, B-N, C-N A-B ^② , B-C ^② , C-A ^②	3-5
3 \emptyset , 4-wire Wye, Ground	41	3	Neut	3	Wye-Wye	A, B, C, N, G ^②	A-N, B-N, C-N A-B ^② , B-C ^② , C-A ^②	3-6
3 \emptyset , 4-wire Wye, Ground ^③	40	2	None	3	Wye-Wye	A, B, C, N ^②	A-N, B-N, C-N A-B ^② , B-C ^② , C-A ^②	3-7
3 \emptyset , 4-wire Wye, Ground	42	3	None	2	Open Wye	A, B, C, N ^②	A-N, B-N ^② , C-N A-B ^② , B-C ^② , C-A ^②	3-8
3 \emptyset , 4-wire Wye, Ground	43	3	Neut	2	Open Wye	A, B, C, N, G ^②	A-N, B-N ^② , C-N A-B ^② , B-C ^② , C-A ^②	3-9

^① The System ID is used during setup to specify the system type.

^② Indicates a value that is calculated rather than measured directly.

^③ For 3-wire loads only.

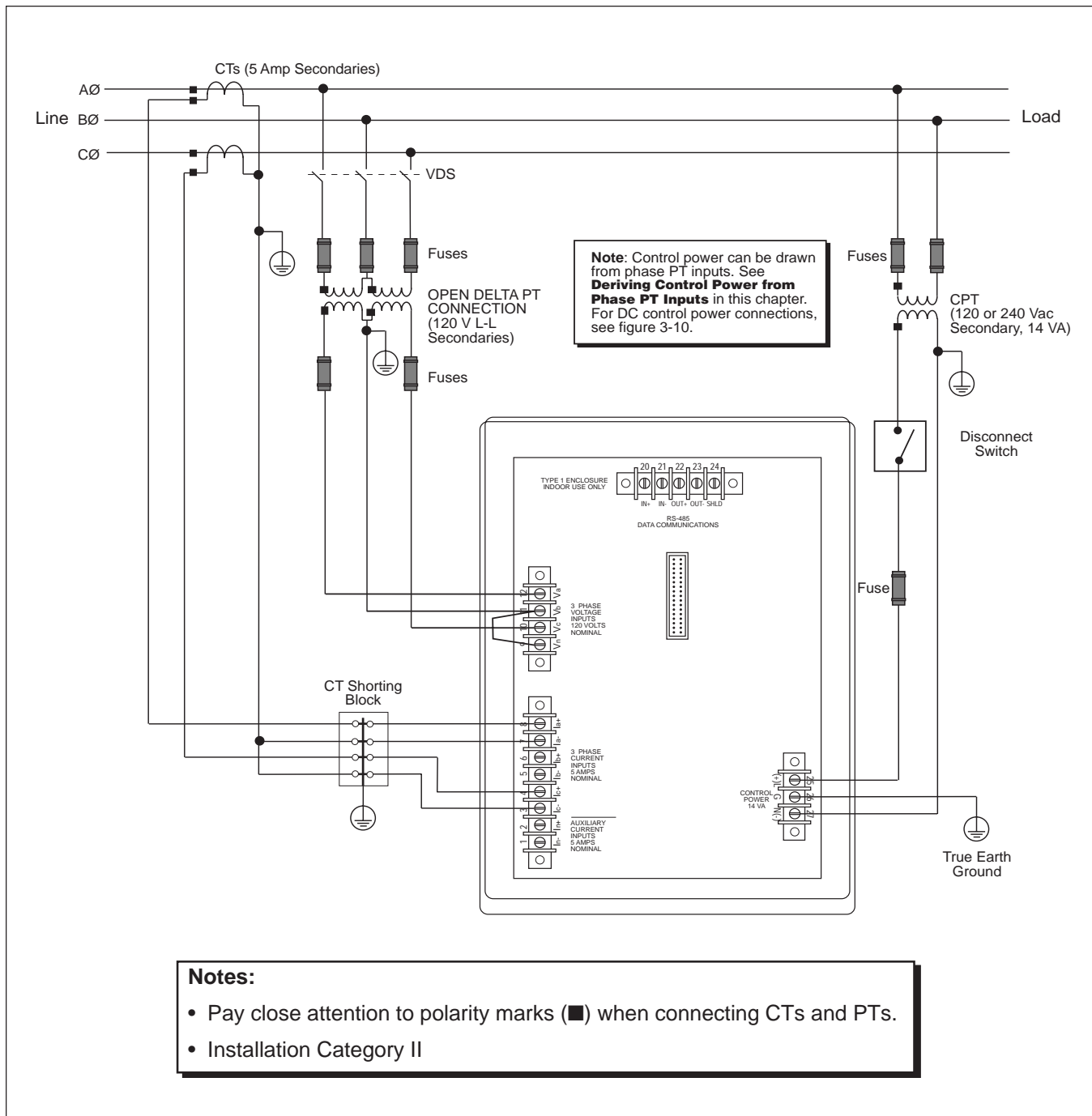

Figure 3-4: 3-phase, 3-wire delta connection

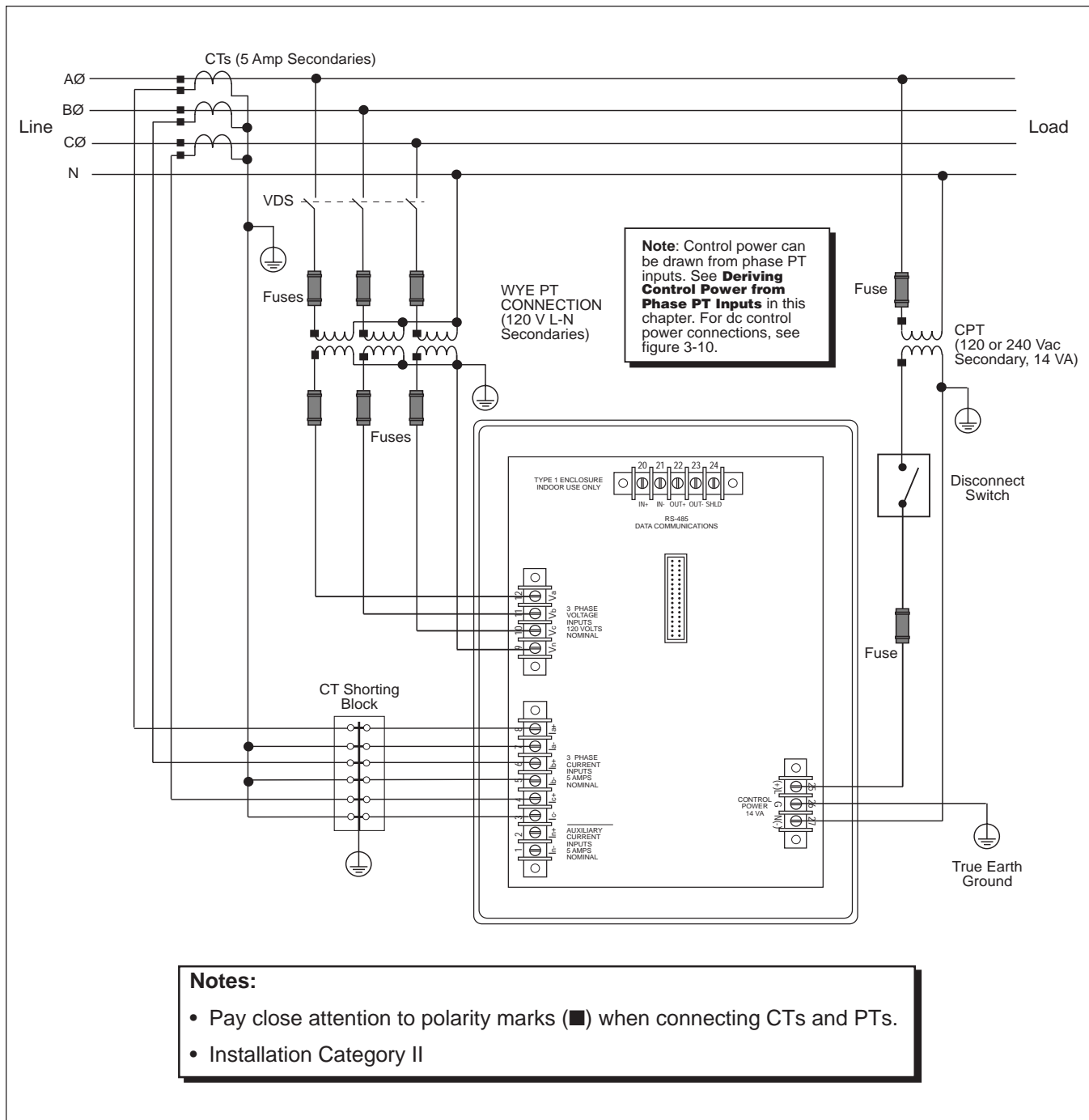

Figure 3-5: 3-phase, 4-wire wye, ground connection

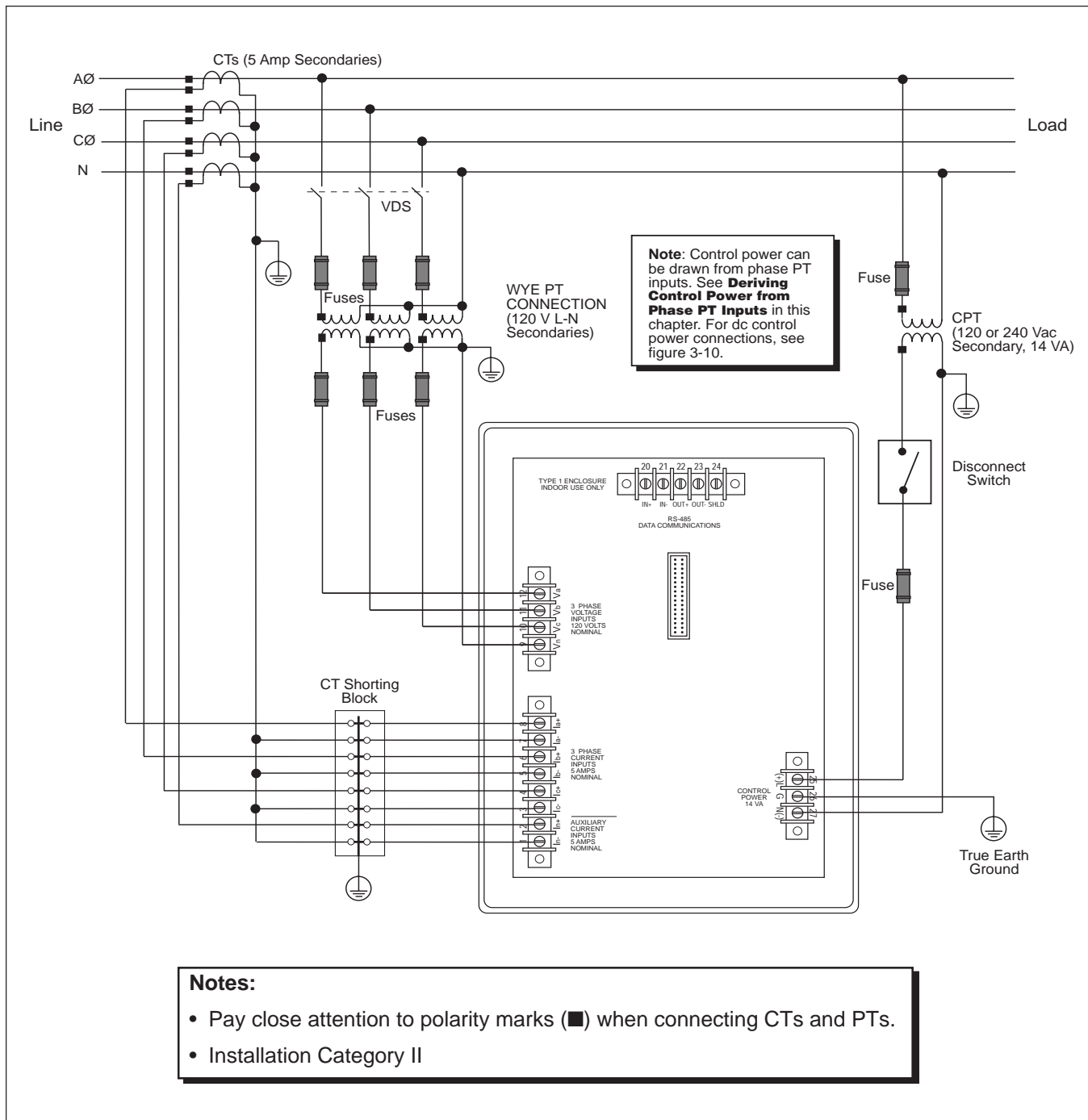

Figure 3-6: 3-phase, 4-wire wye, ground connection, metered neutral

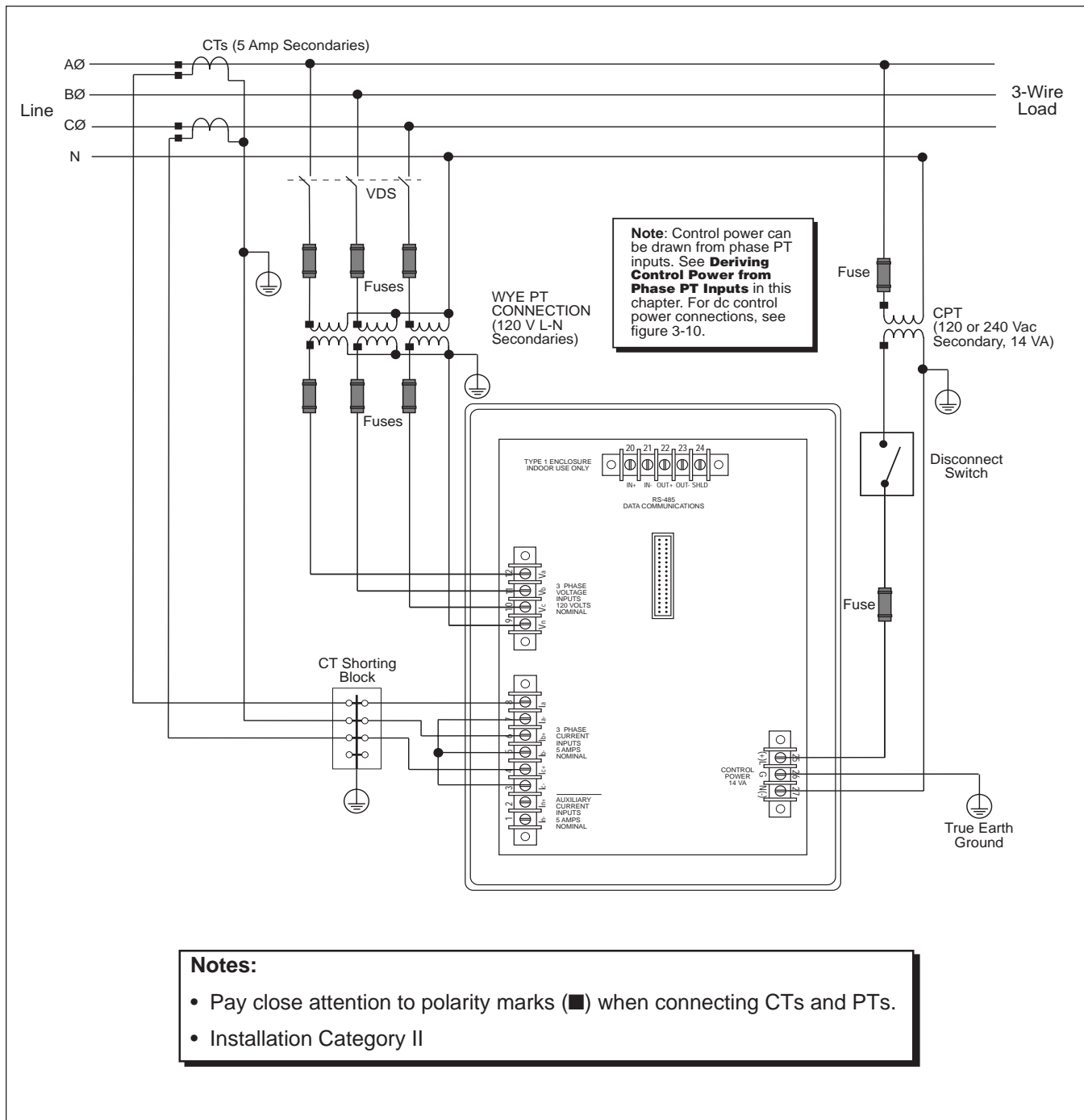

Figure 3-7: 3-phase, 4-wire wye, 3-wire load

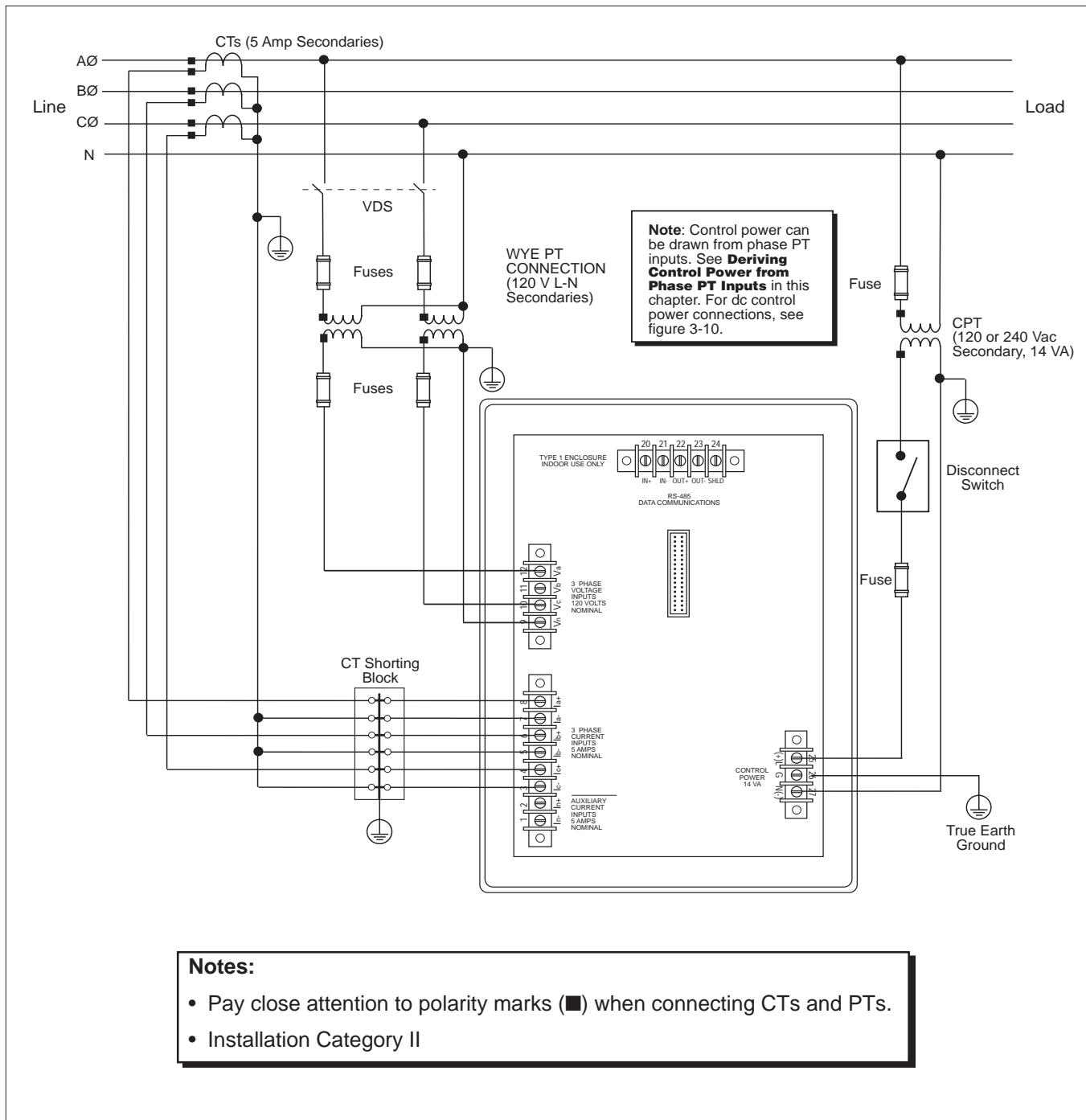

Figure 3-8: 2-1/2 element metering system type 42 (calculated neutral)

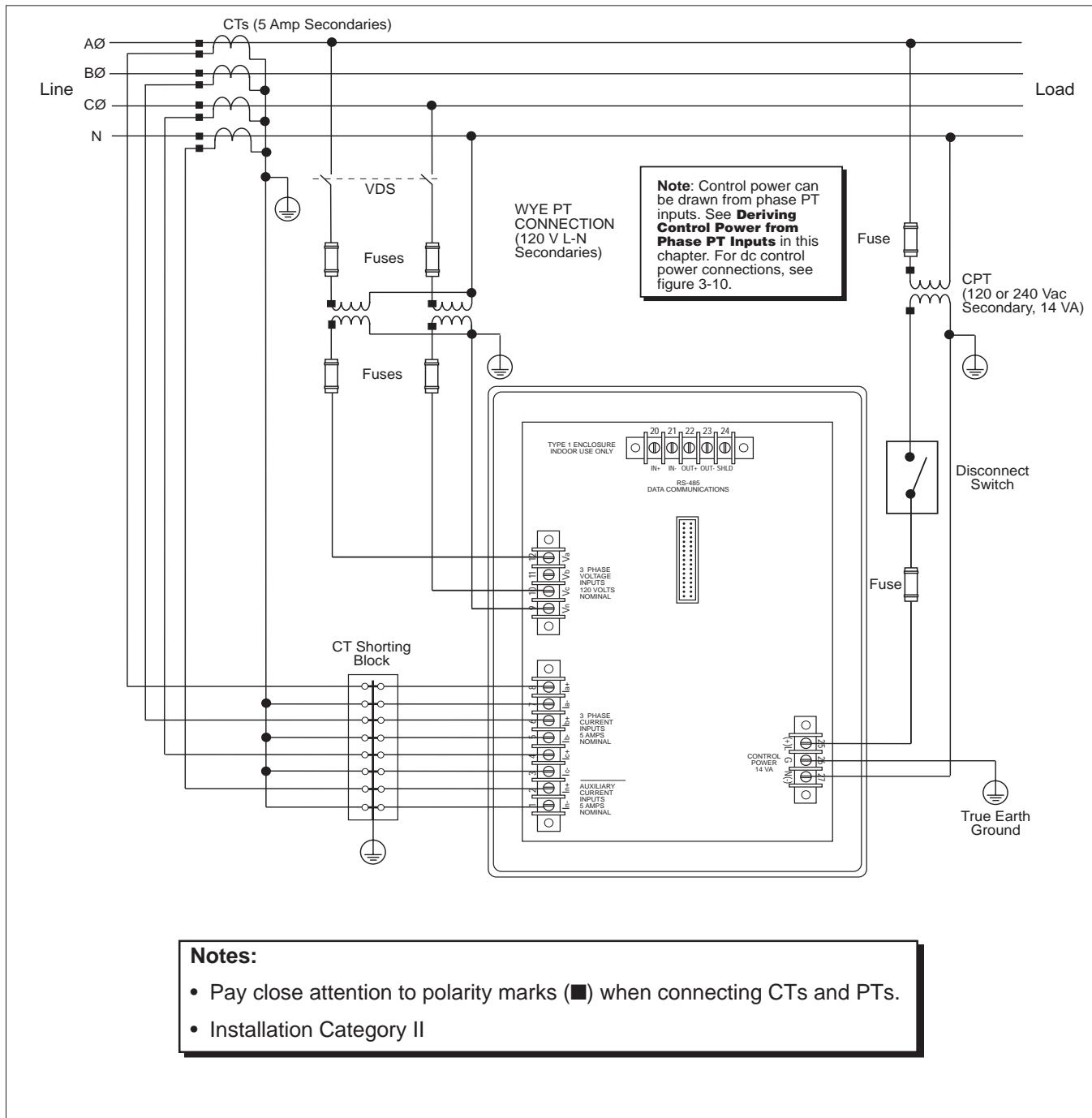

Figure 3-9: 2-1/2 element metering system type 43

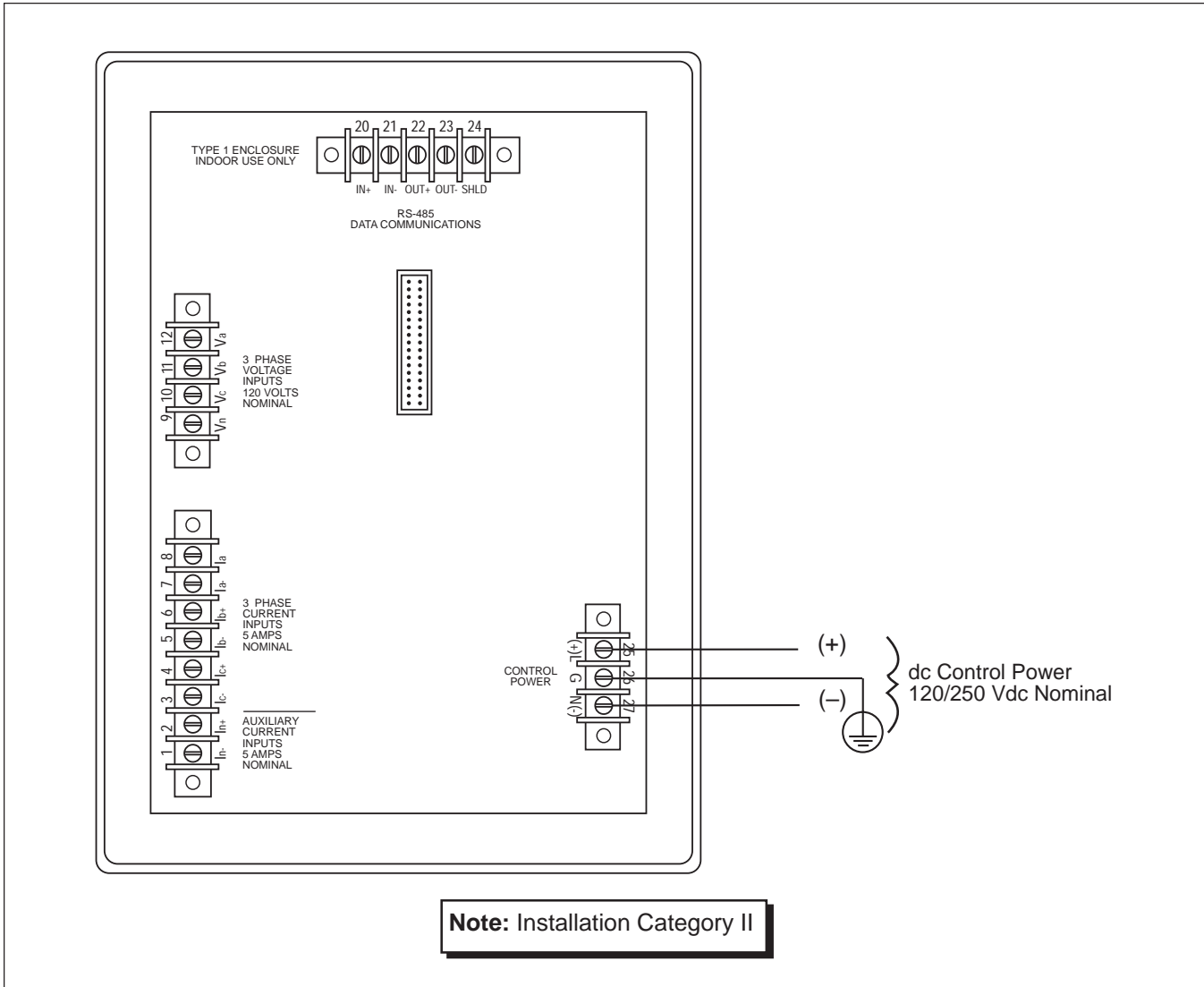

Figure 3-10: DC control power connections

Wiring Multiple Circuit Monitors to a Single Set of PTs/CPT

Multiple circuit monitors can share one set of 3-phase PTs. Also, multiple circuit monitors can share a single control power transformer (CPT). In all cases, each circuit monitor must use a separate set of CTs. Figure 3-11 shows how to connect multiple circuit monitors to a single set of PTs and CPT.

Note: When using this wiring method, ground the PT secondaries in only one location.

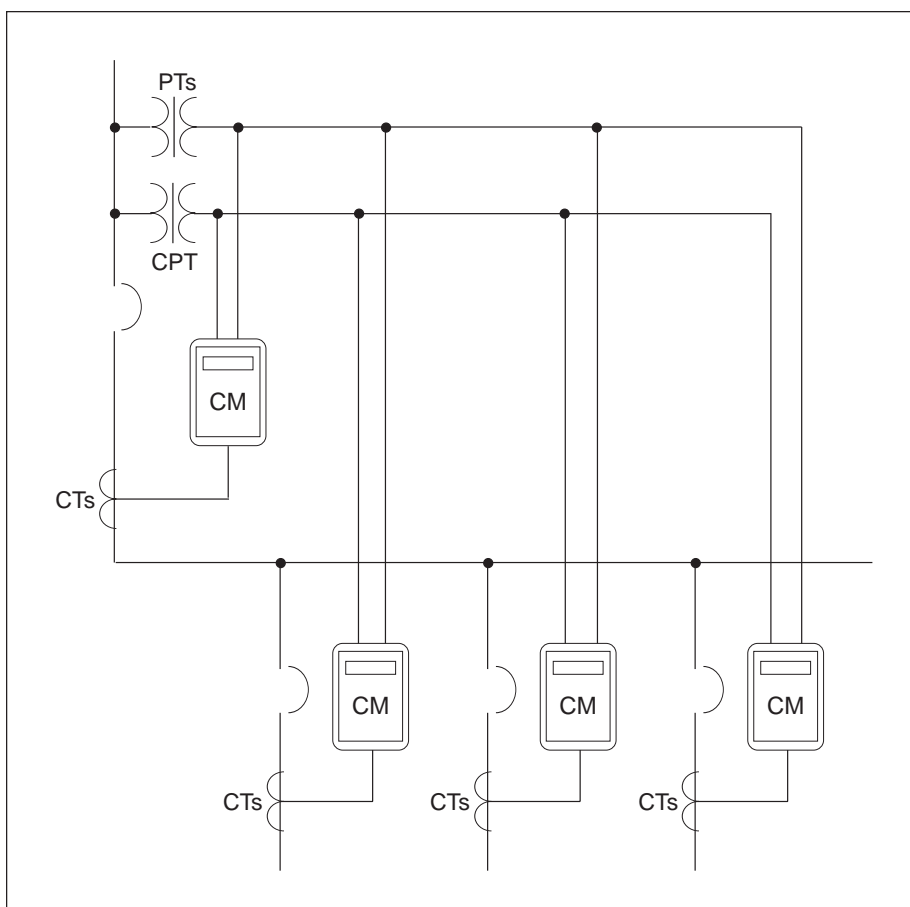

Figure 3-11: Circuit monitors connected to one set of PTs and one CPT

Deriving Control Power from Phase PT Inputs

Whenever possible, derive circuit monitor control power from a stable voltage source. If such a source is unavailable, the circuit monitor can derive control power from its phase PT inputs. Due to the wide range of permissible control power inputs, the circuit monitor can accept either L-N or L-L control power inputs up to 240 V nominal. Using the L-L control power option increases the circuit monitor ride-through time and enables more reliable operation during voltage disturbances.

Referring to figures 3-12 and 3-13, complete the following steps to derive control power from phase PT inputs:

1. Connect the Va terminal (terminal 12) to the L terminal (terminal 25).
2. For L-N control power, connect the Vn terminal (terminal 9) to the N terminal (terminal 27). For L-L control power, connect the Vc terminal (terminal 10) to the N terminal (terminal 27).
3. Install protective terminal strip covers. See **Appendix C** for instructions.



CAUTION

HAZARD OF EQUIPMENT DAMAGE

When deriving control power from the phase PT inputs, the phase PT used must have a VA rating sufficient for all connected burdens. If the VA rating is exceeded, it could reduce the voltage transformer's accuracy or damage the PT.

Failure to observe this precaution can result in equipment damage.

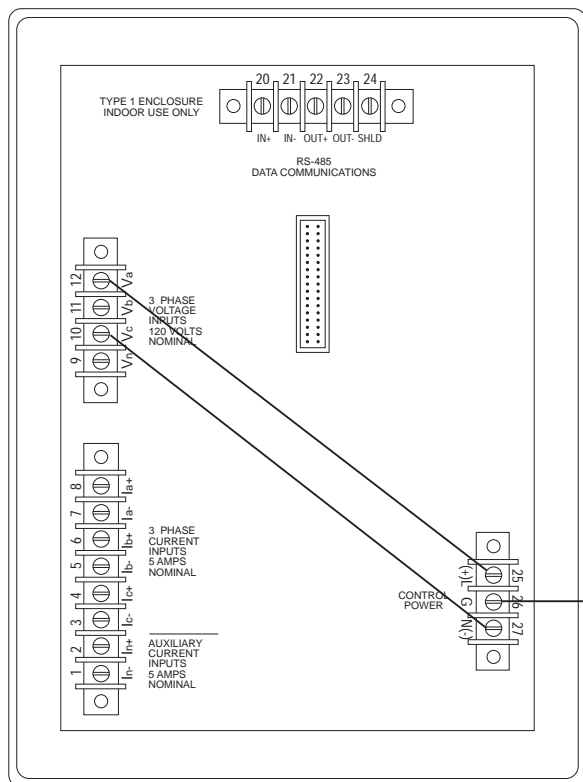

Figure 3-12: Deriving L-L control power from phase PT inputs

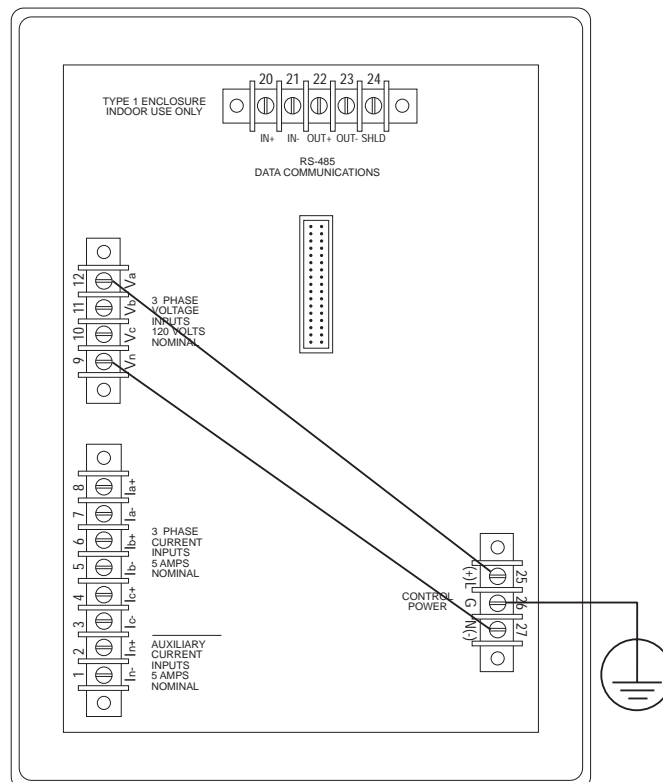

Figure 3-13: Deriving L-N control power from phase PT inputs

GROUNDING THE CIRCUIT MONITOR

For optimal grounding, connect the circuit monitor to a true earth ground.

To ground the circuit monitor, complete the following steps:

1. Connect the Ground terminal (terminal 26) to a true earth ground, using #14 AWG wire or larger with spade connector (see figure 3-14).
2. Install protective terminal strip cover. See **Appendix C** for instructions.

! DANGER

HAZARD OF ELECTRIC SHOCK

Ground the circuit monitor as described in these instructions. Failure to properly ground the circuit monitor may allow hazardous voltages to be present on the circuit monitor chassis, and may result in equipment damage.

Failure to observe this precaution will result in death, serious injury or equipment damage.

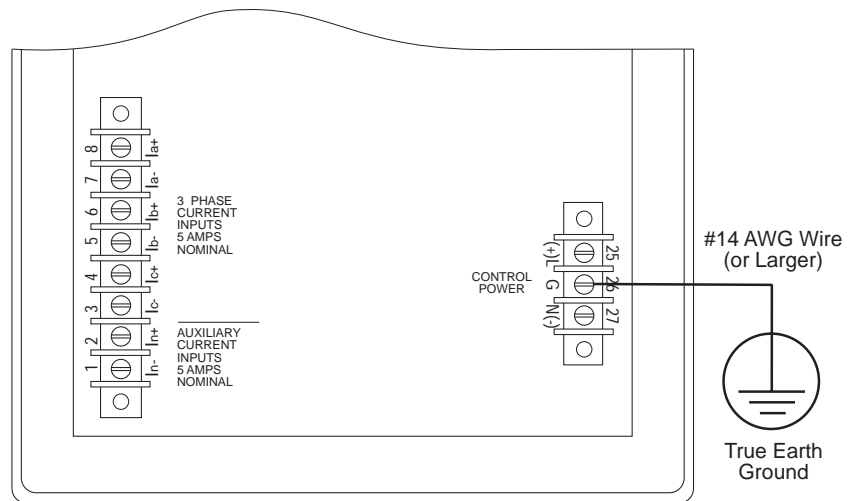

Figure 3-14: Grounding the circuit monitor

COMMUNICATIONS WIRING

POWERLOGIC devices are equipped with RS-485 communications. The RS-485 standard lets you daisy-chain up to 32 POWERLOGIC-compatible devices to a single communications port. This document refers to a chain of POWERLOGIC devices connected by communications cable as a *communications link*.

A POWERLOGIC communications link can consist of up to 32 POWERLOGIC-compatible devices connected to a communications port on one of the following:

- POWERLOGIC System Display
- Personal computer
- POWERLOGIC Network Interface Module
- SY/MAX[®] programmable controller
- Other host devices with a POWERLOGIC-compatible port

Figures 3-15 through 3-19 show circuit monitors and other POWERLOGIC compatible devices connected in typical systems. The accompanying text describes important considerations for each connection alternative.

The figures also show the placement of communications adapters and terminators. For additional information on using the communications adapter and terminator, see **Terminating the Communications Link** and **Biasing the Communications Link** in this chapter.

Connecting to a System Display

- Connect up to 32 circuit monitors to the system display for Circuit Monitors (Class 3050 Types SD-200, SD-220). See **Length of the Communications Link** in this chapter for distance limitations at varying baud rates.
- Connect circuit monitors to the RS-485 port on the bottom of the system display.
- Configure the system display's baud rate to match the baud rate of circuit monitors on the communications link.
- Refer to the instruction bulletin for the system display for circuit monitors (Class 3050 Types SD-200, SD-220) for detailed instructions on configuring the system display.

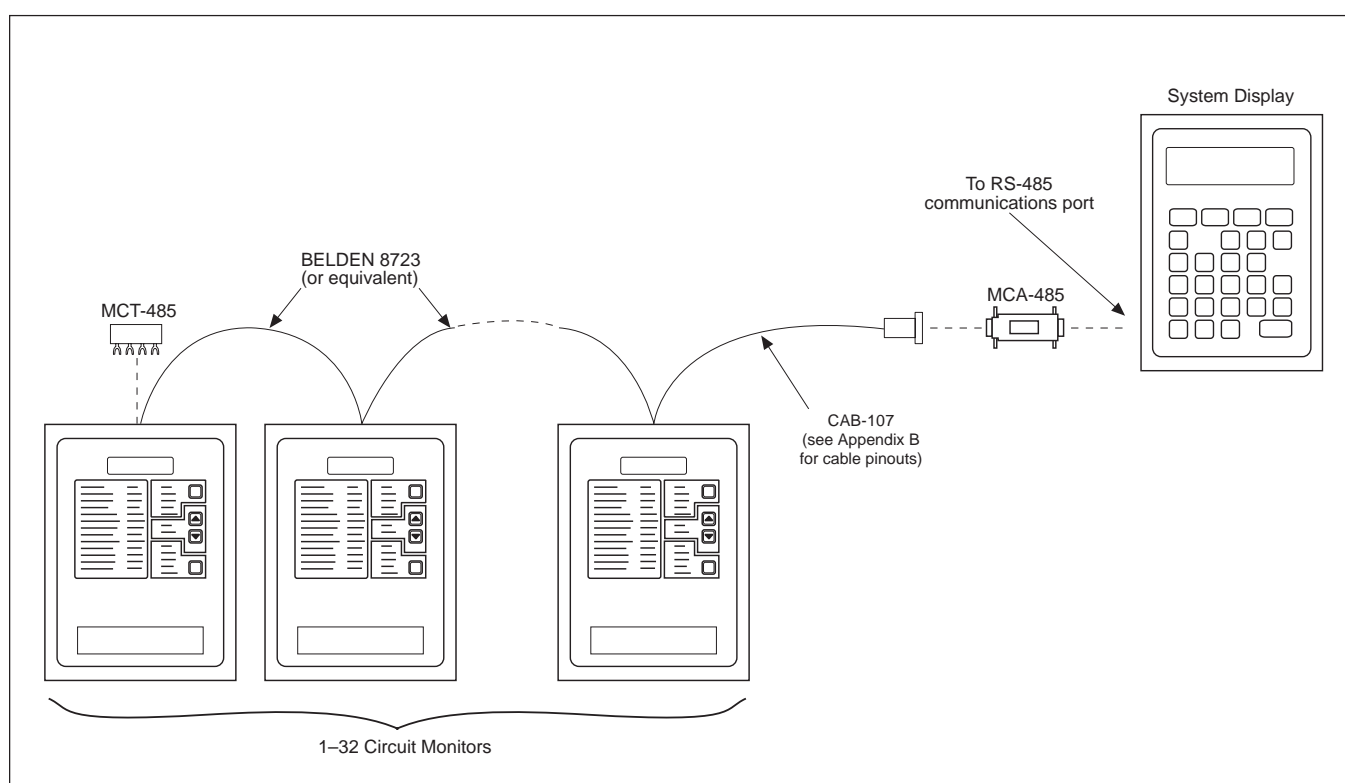

Figure 3-15: Circuit monitors connected to a system display for circuit monitors

Connecting to a Personal Computer

- Connect up to 32 POWERLOGIC devices to a personal computer. See **Length of the Communications Link** in this chapter for distance limitations at varying baud rates.
- POWERLOGIC devices can be connected to a SY/LINK card installed in the personal computer. To do this, connect the POWERLOGIC devices to the RS-422 port (female DB-9 connector) of the SY/LINK card.
- POWERLOGIC devices can be connected to a serial COMM port on the personal computer. To do this, the POWERLOGIC devices must be connected to an RS-232 to RS-422/RS-485 converter which is connected to the personal computer. POWERLOGIC offers a converter kit for this purpose (Class 3090 Type MCI-101). Refer to the instruction bulletin included with the MCI-101 for connection instructions.

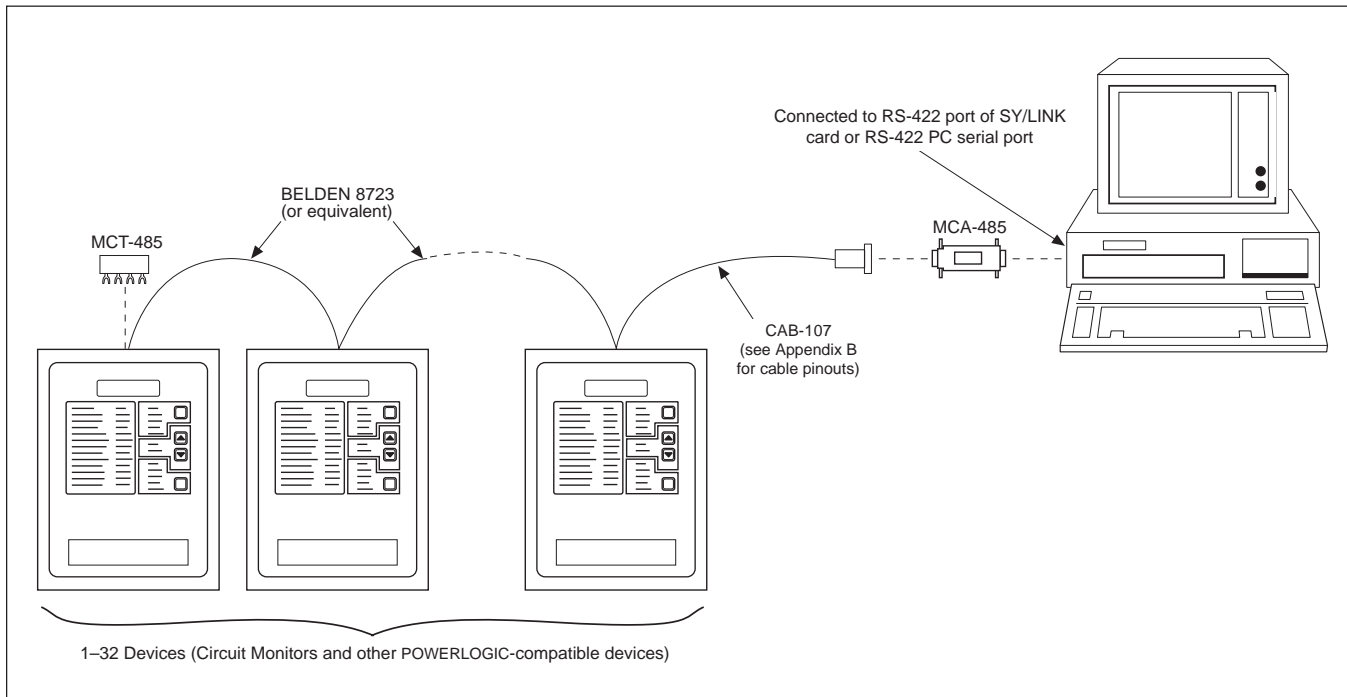

Figure 3-16: POWERLOGIC devices connected directly to a personal computer

Connecting to a POWERLOGIC Ethernet Gateway (EGW)

- There are two models of the POWERLOGIC Ethernet Gateway: a single port version (EGW1) and a dual port version (EGW2).
- The serial port on the EGW1 can support up to 8 POWERLOGIC devices.
- Each serial port on the EGW2 can support up to 32 POWERLOGIC devices on a daisy-chain, or up to 64 devices when a signal repeater is used.
- Connection to the Ethernet can be made via a UTP or AUI port.

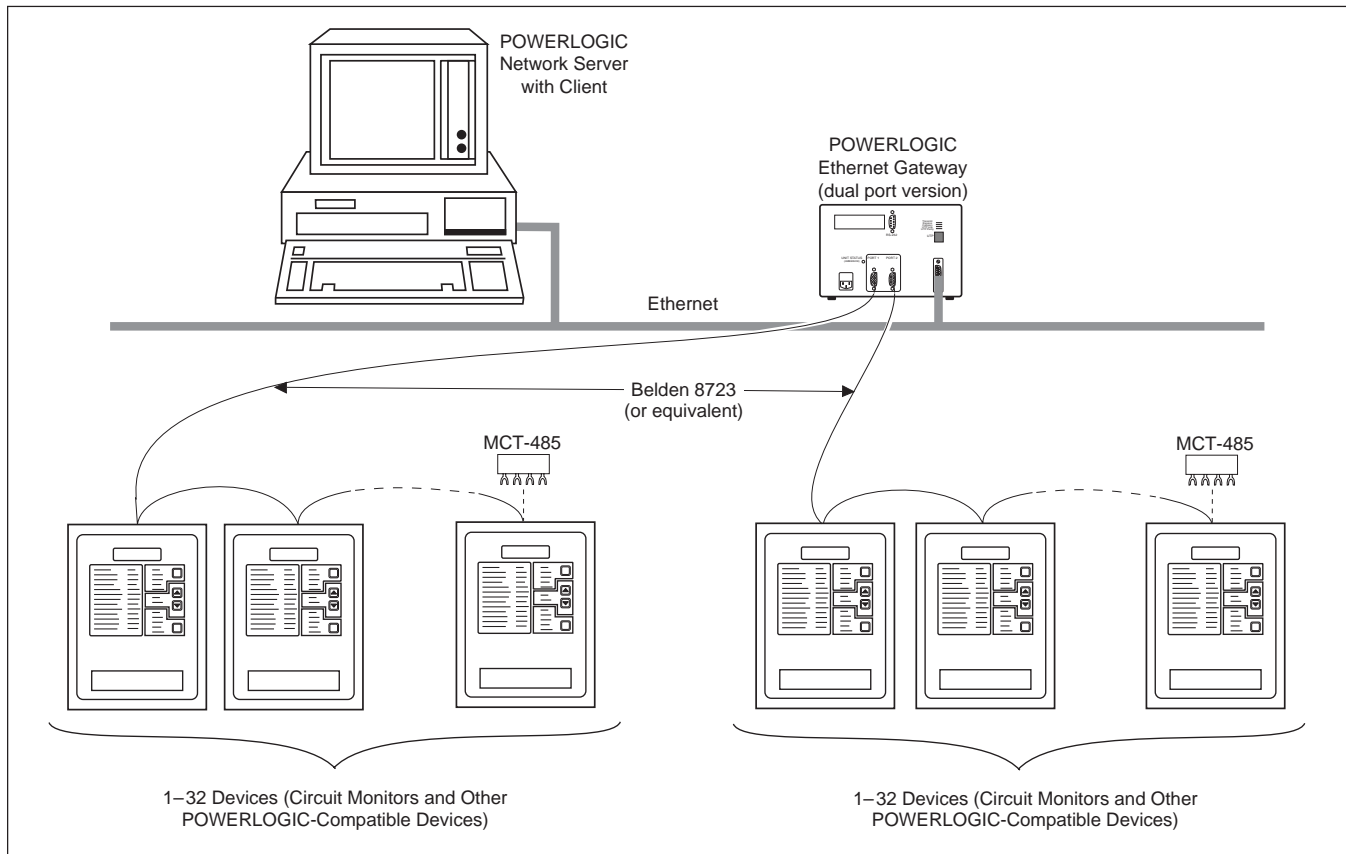

Figure 3-17: POWERLOGIC devices connected to an Ethernet gateway

Connecting to a POWERLOGIC Network Interface Module (PNIM)

- Connect up to 32 POWERLOGIC devices to a PNIM. See **Length of the Communications Link** in this chapter for distance limitations at different baud rates.
- Connect POWERLOGIC devices to PNIM port 0 (top RS-485 port) only.
- Configure PNIM port 0 for "POWERLOGIC" mode. (See side of PNIM for instructions on setting dip switches.)
- Configure the baud rate of PNIM port 0 to match the baud rate of the POWERLOGIC devices on the communications link.
- Refer to the PNIM instruction bulletin for detailed instructions on configuring the PNIM.

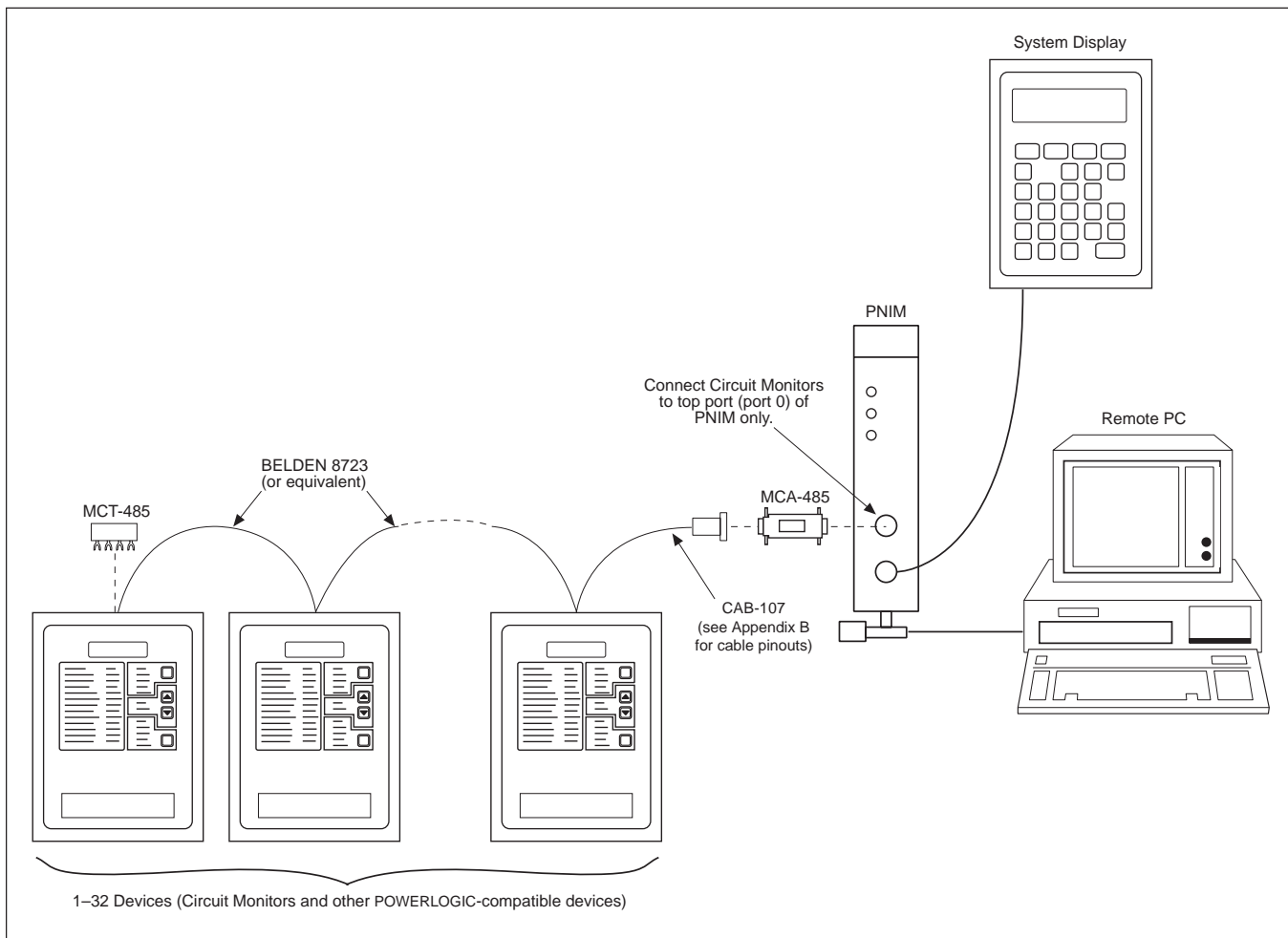

Figure 3-18: POWERLOGIC devices connected to a PNIM

Connecting to a SY/MAX Programmable Controller

- Connect up to 32 POWERLOGIC devices to a programmable controller. See **Length of the Communications Link** in this chapter for distance limitations at different baud rates.
- Connect POWERLOGIC devices to the RS-422 port of the programmable controller.
- The programmable controller must contain a program to access POWERLOGIC device data.
- Configure the baud rate of the programmable controller's port to match the baud rate of the POWERLOGIC devices on the communications link.
- Refer to the programmable controller instruction manual for detailed instructions on configuring the programmable controller.

Note: POWERLOGIC devices can be connected to other manufacturer's systems using available communication interfaces. For further information, contact the POWERLOGIC Technical Support Center. See **Getting Technical Support** in Chapter 5.

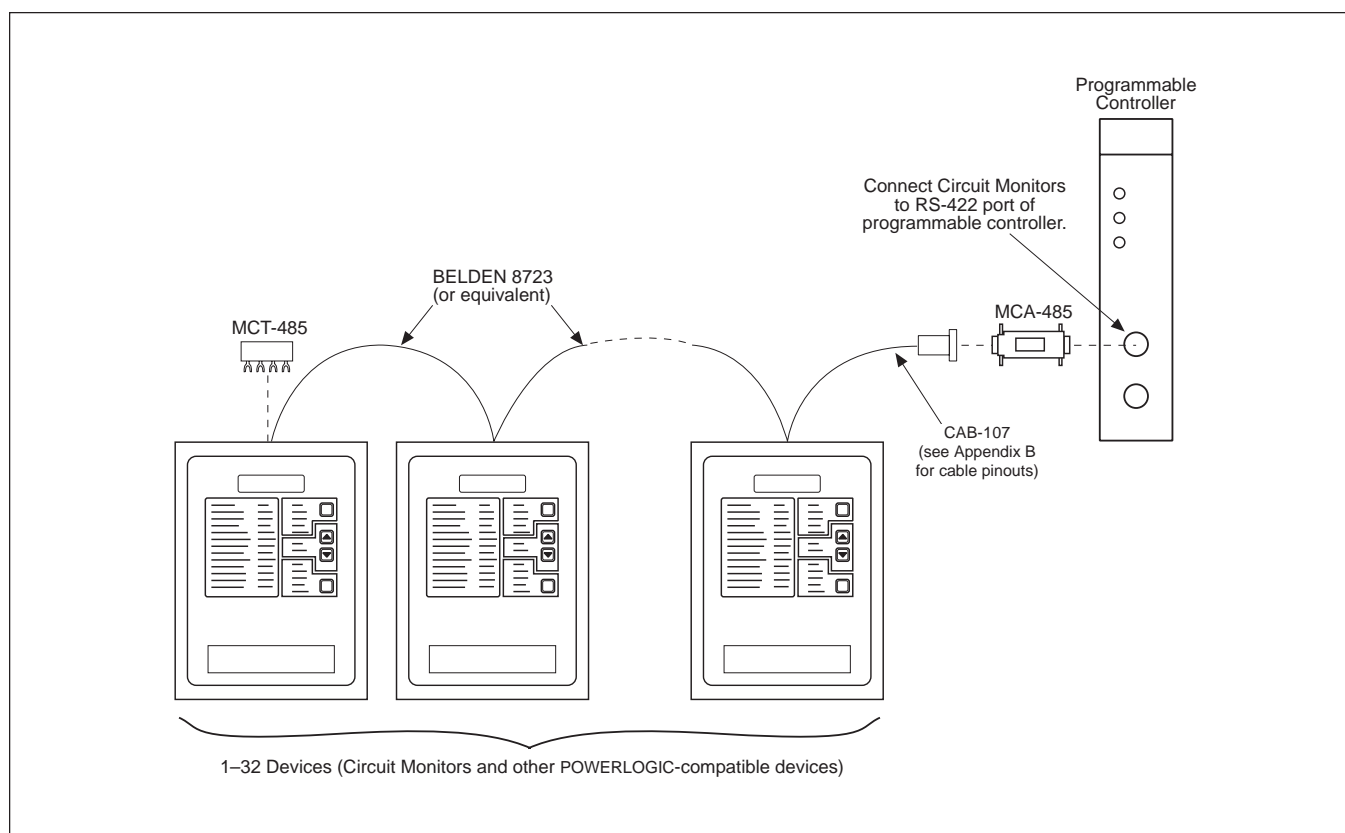

Figure 3-19: POWERLOGIC devices connected to a SY/MAX programmable controller

**Length of the
Communications Link**

The length of the communications link cannot exceed 10,000 feet (3,050 m). This means that the total length of the communications cable from the PNIM, personal computer, system display, or processor, to the last device in the daisy-chain, cannot exceed 10,000 feet. When 17 or more devices are on a communications link, the maximum distance may be shorter, depending on the baud rate. Table 3-3 shows the maximum distances at different baud rates.

**Table 3-3
Maximum Distances of Comms Link at Different Baud Rates**

Baud Rate	Maximum Distances	
	1-16 devices	17-32 devices
1200	10,000 ft (3,050 m)	10,000 ft (3,050 m)
2400	10,000 ft (3,050 m)	5,000 ft (1,525 m)
4800	10,000 ft (3,050 m)	5,000 ft (1,525 m)
9600	10,000 ft (3,050 m)	4,000 ft (1,220 m)
19200	10,000 ft (3,050 m)	2,500 ft (762.5 m)

Daisy-Chaining POWERLOGIC Devices

Note: To daisy-chain POWERLOGIC devices, use communications cable containing two twisted-shielded pairs (Belden 8723 or equivalent). Connect the wires to the circuit monitor's terminals using the red spade connectors included with the circuit monitor. Using a suitable crimping tool, crimp the red connectors onto the communications wires.

Each communicating POWERLOGIC device has five RS-485 terminals for connection to a POWERLOGIC communications link. On all devices, the terminals are labeled IN+, IN-, OUT+, OUT-, and SHLD. On the circuit monitor, the IN+, IN-, OUT+, OUT-, and SHLD terminals are numbered 20, 21, 22, 23, and 24, respectively.

To daisy-chain the circuit monitor to another POWERLOGIC device, wire the circuit monitor's RS-485 communications terminals to the matching communications terminals of the next device. In other words, wire the IN+ terminal of the circuit monitor to the IN+ terminal of the next device, wire IN- to IN-, OUT+ to OUT+, OUT- to OUT-, and SHLD to SHLD. See Figure 3-20.

If the circuit monitor is the last device on the daisy-chain, terminate it. See **Terminating the Communications Link** in this chapter for instructions. If the circuit monitor is the first device on the daisy-chain, connect it to the PNIM, personal computer, system display, or programmable controller using a CAB-107 or equivalent cable and a Multipoint Communications Adapter. See **Biasing the Communications Link** in this chapter for instructions. See **Communication Cable Pinouts** in the *Circuit Monitor Reference Manual* for the CAB-107 pinout.

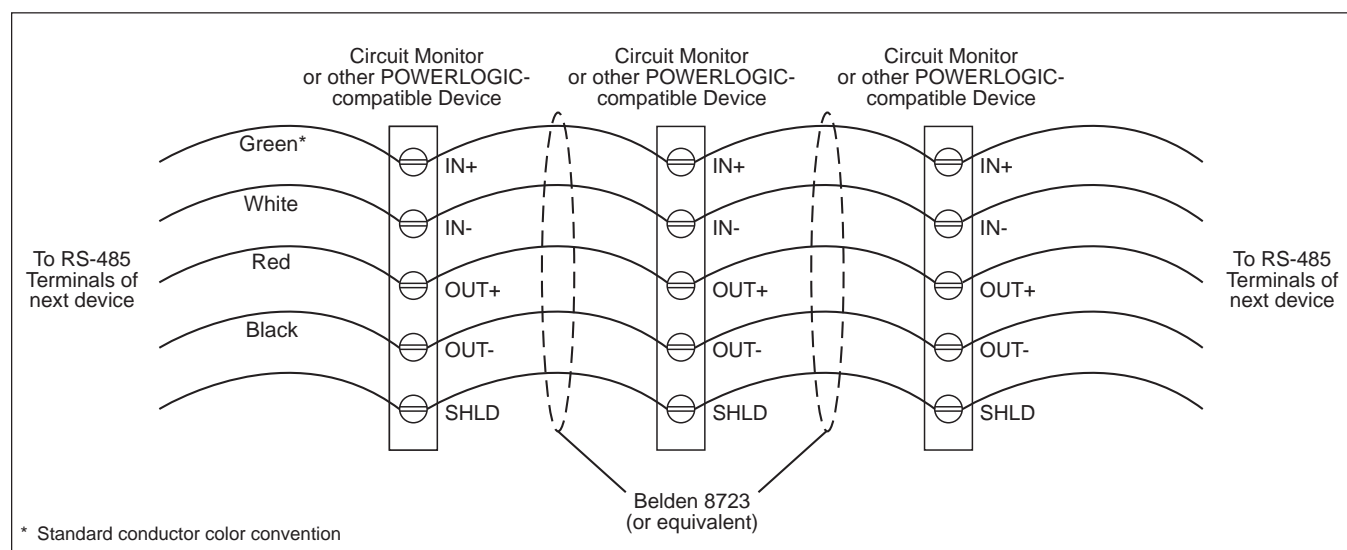

Figure 3-20: Daisy-chaining the RS-485 communications terminals

Terminating the Communications Link

To ensure reliable communications, terminate the last device on a POWERLOGIC communications link. To terminate the last device, use a POWERLOGIC Multipoint Communications Terminator (Class 3090 Type MCT-485).

To terminate a circuit monitor, slide the terminator's four spade connectors under the IN+, IN-, OUT+, and OUT- terminals on the back of the circuit monitor and tighten. Figure 3-20 shows proper placement of the terminator. Figures 3-15 to 3-19 show the terminator applied in typical systems.

Notes:

- *Terminate only the last device on the link. If a link has only one device, terminate that device.*
- *Some POWERLOGIC devices use a removable communications connector. If the last device on the communications link is not a circuit monitor, refer to the instruction bulletin for that device for termination instructions.*

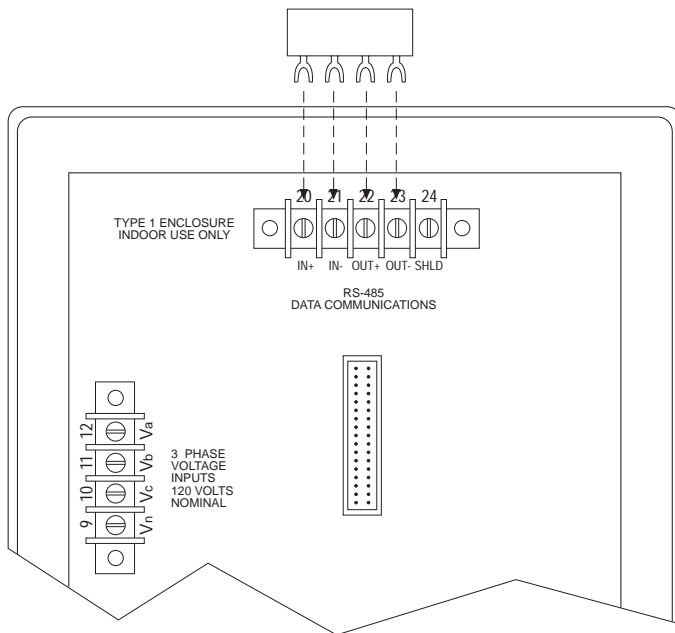

Figure 3-21: Terminator placement when last device on the link is a circuit monitor

Biasing the Communications Link

To ensure reliable communications, bias the communications link. To bias the communications link, use a POWERLOGIC Multipoint Communications Adapter (Class 3090 Type MCA-485).

To bias the communications link, plug the adapter into the communications port of the device to which one or more POWERLOGIC devices are connected. Plug the CAB-107 cable connected to the first POWERLOGIC device on the link into the other end of the adapter.

Figure 3-22 shows the adapter connected to a POWERLOGIC Network Interface Module (PNIM). Figures 3-15, 3-16, 3-18, and 3-19 show the adapter applied in typical systems.

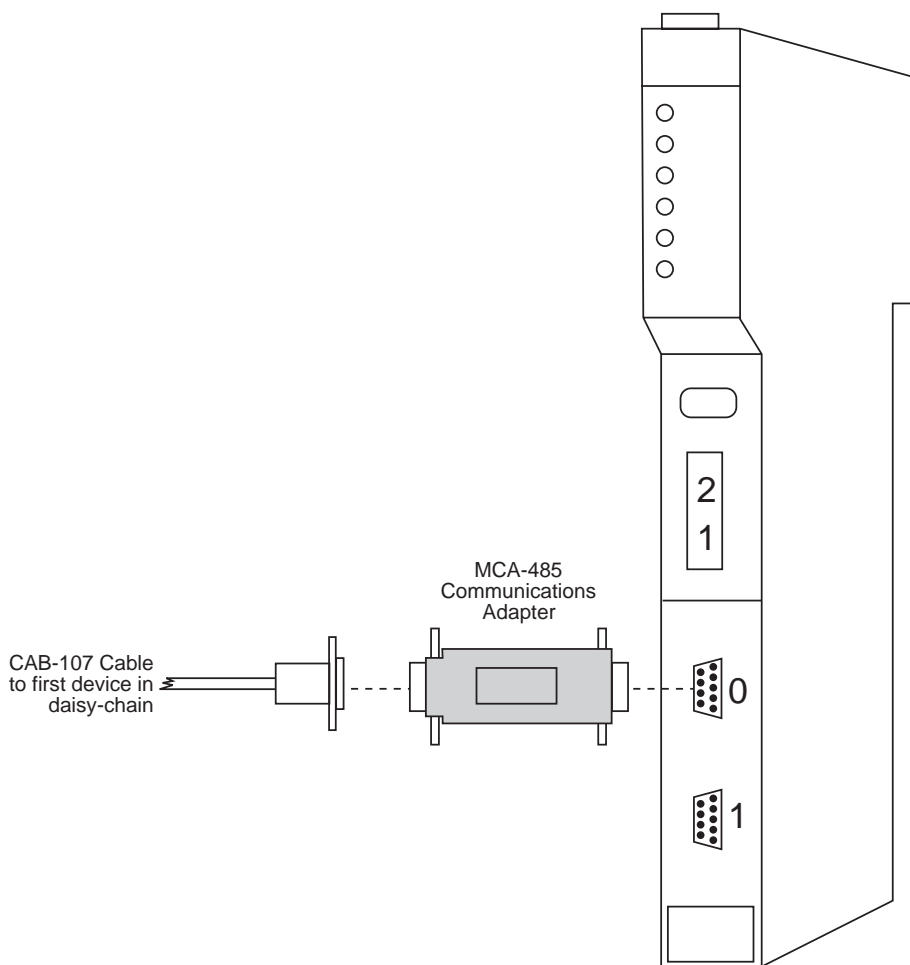

Figure 3-22: Multipoint Communications Adapter connected to PNIM

CHAPTER 4—FRONT PANEL OPERATION

CHAPTER CONTENTS

This chapter tells how to set up the circuit monitor from the front panel only. Some advanced circuit monitor features, such as event log/data log configuration, must be set up over the communications link. You can set up these advanced features using POWERLOGIC software. Refer to the software instruction bulletin for instructions on setting up advanced features.

The Setup Mode	40
The Configuration Option	40
The Resets Option	40
The Alarm/Relay Option	40
The Diagnostics Option	40
Choosing a Setup Option	41
How the Buttons Work	41
Configuring the Circuit Monitor	42
Factory Defaults	42
General Configuration Procedure	42
Viewing Configuration Data in Protected Mode	45
Setting the Master Password	46
Setting the CT Ratios	47
Setting the PT Ratio	48
Setting the System Type	48
Setting the Demand Interval	49
Setting the Watthour/Pulse Output	51
Setting the Device Address	52
Setting the Baud Rate	53
Setting the Nominal Frequency	54
Resetting Demand, Energy, and Min./Max. Values	55
Performing Resets Using The Resets Option	56
Setting Up Alarm/Relay Functions	58
General Setup Procedure	59
Detailed Setup Procedure	60
Viewing Active Alarms	63
Viewing the Priority 1 Log	64
Clearing the Priority 1 Log	65

THE SETUP MODE

To access the Setup Mode, press the MODE button until the red LED next to [Setup] is lit. The circuit monitor displays “Config”—the first of four setup options. The circuit monitor displays the options as abbreviated combinations of uppercase and lowercase letters. The abbreviations displayed by the circuit monitor, and their full names are shown below.

<u>Full Name</u>	<u>CM Display</u>
Configuration Option	ConFig
Resets Option	rESETs
Alarm/Relay Option	AL.rLy
Diagnostics Option	diAG

The Configuration Option

The Configuration option lets you configure the following values: CT and PT primaries, system type, demand interval, WH/pulse output, device address, baud rate, nominal frequency, and password. You can also reset energy, demand, and min/max values. See **Configuring the Circuit Monitor**, page 42, for more information.

The Resets Option

The Resets option lets you reset energy, demand and min/max values. These same reset operations can be done using the Configuration option. The difference is that using the Resets option, you cannot change circuit monitor configuration values. See **Performing Resets Using the Resets Option** in this chapter for more information.

The Alarm/Relay Option

The Alarm/Relay option lets you configure the circuit monitor’s on-board alarm/relay functions. (See **Alarm Setup Information** in the *Circuit Monitor Reference Manual* for a complete listing of the circuit monitor’s predefined alarm conditions.) For each of the circuit monitor’s predefined alarm conditions, you can:

- Enable or disable it
- Assign a priority to it
- Define any required pickup and dropout setpoints, and pickup and dropout time delays
- Setup the circuit monitor to operate up to three relay outputs when the alarm condition occurs

See **Setting Up Alarm/Relay Functions** in the *Circuit Monitor Reference Manual* for details on how to use this option.

The Diagnostics Option

The Diagnostics option lets you read and write circuit monitor registers. Use this feature with caution. Writing an incorrect value, could cause the circuit monitor to operate incorrectly. See **Reading and Writing Registers from the Front Panel** in the *Circuit Monitor Reference Manual* for instructions on reading and writing registers using the Diagnostics option.

Choosing a Setup Option

To enter the [Setup] mode, press the MODE button until the [Setup] LED is lit. The circuit monitor displays “ConFig.” To move to a specific option, use the SELECT METER [Value] buttons. To select an option, press the PHASE [Enter] button (see figure 4-1).

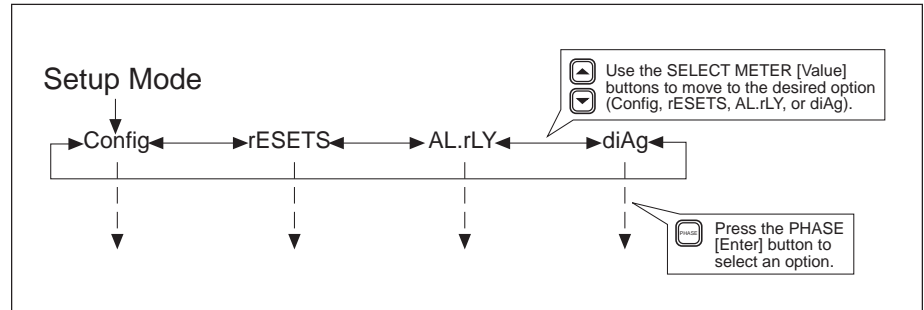

Figure 4-1: Choosing a Setup option

How the Buttons Work

The circuit monitor’s front panel buttons perform different functions in Setup mode than in Meters mode. In Setup mode, the buttons work as described below.



The PHASE [Enter] button. In Setup mode, use this button as an “Enter” key to accept a new configuration value and move to the next configuration item. For example, after changing the CT Primary value, press this button to enter the new value and move to the next configuration item (PT Primary). Also, press this button to move through configuration items that don’t need to be changed, to reach a specific item.



SELECT METER [Value] buttons. In Setup mode, use these buttons to increase or decrease the displayed value. Also, use these buttons to toggle between *Yes* and *No* when required.



MODE button. Use this button to exit a setup option after making all desired changes. For example, after making all desired changes within the Configuration option, press the mode key. The circuit monitor then asks you to accept or reject your changes.



CONFIGURING THE CIRCUIT MONITOR

This section tells how to use the Configuration option to define the following values: CT and PT ratios, system type, demand interval, WH/pulse output, device address, baud rate, nominal frequency, and password. It also tells how to reset energy, demand and min/max values.

The section **General Configuration Procedure** describes the general steps required to configure the circuit monitor. The remaining sections tell how to configure specific values.

Factory Defaults

Table 4-1 lists the front panel configuration parameters, their allowed values, and their factory defaults.

Table 4-1
Factory Defaults for Front Panel Configuration Parameters

Parameter	Allowed Values	Default
CT Primary		
Primary, 3-Phase	1 to 32,767	5
Primary, Neutral	1 to 32,767	5
PT Primary		
Primary, 3-Phase	1 to 1,700,000	120
System Type	30, 40, 41	40
Demand Interval	5 to 60 min.	15
WH/Pulse output	0 to 3276.7 kWH	0
Device Address	0 to 199	1
Baud Rate	1,200–19,200	9,600
Frequency (Nom.)	50, 60, 400	60
Password	0 to 9998	0

General Configuration Procedure

This section describes the general steps required to configure the circuit monitor from the front panel. The configuration items (and reset items) are the grey items in square brackets on the front panel of the circuit monitor. Refer to these items when configuring the circuit monitor.

The front panel configuration procedure is described below. Alternately, figure 4-2 on page 44 shows the configuration procedure, with less detail, as a flow chart.

To configure the circuit monitor, complete the following steps:

1. Press the MODE button until the red LED next to [Setup] is lit.
The circuit monitor displays "ConFig".
2. Press the PHASE [Enter] button to select the Configuration option.
The circuit monitor displays the password prompt "P - - - -."

3. Enter the password.
To enter the password, use the SELECT METER [Value] buttons to increase or decrease the displayed value until it reaches the password value. Then press the PHASE [Enter] button. (The circuit monitor's default password is 0.)
The red LED next to [CT Primary] flashes.
4. Press the PHASE [Enter] button to select a configuration item.
The red LED next to the selected configuration item flashes.
5. Press the SELECT METER [Value] buttons to increase or decrease the displayed value until the desired value is displayed.
In the case of the [Reset] items, use the SELECT METER [Value] buttons to toggle between *Yes* and *No*. See **Resetting Demand, Energy, and Min/Max Values** in this chapter for more on resets.
6. Repeat steps 4 and 5 until you've made all desired configuration changes.
7. After making all desired configuration changes, press the MODE button once.
The red LED next to [Accept] flashes. The circuit monitor display reads *No*, and the red LEDs next to the items that you have changed are lit. Verify that only the LEDs next to the setup items you wish to change are lit.
8. To reject the changes, press the PHASE [Enter] button once.
The circuit monitor returns to Meters mode.
9. To accept the changes, press the SELECT METER [Value] button to change from *No* to *Yes*. Then, press the PHASE [Enter] button.
The circuit monitor goes through its restart procedure. This indicates that the changes have been made.

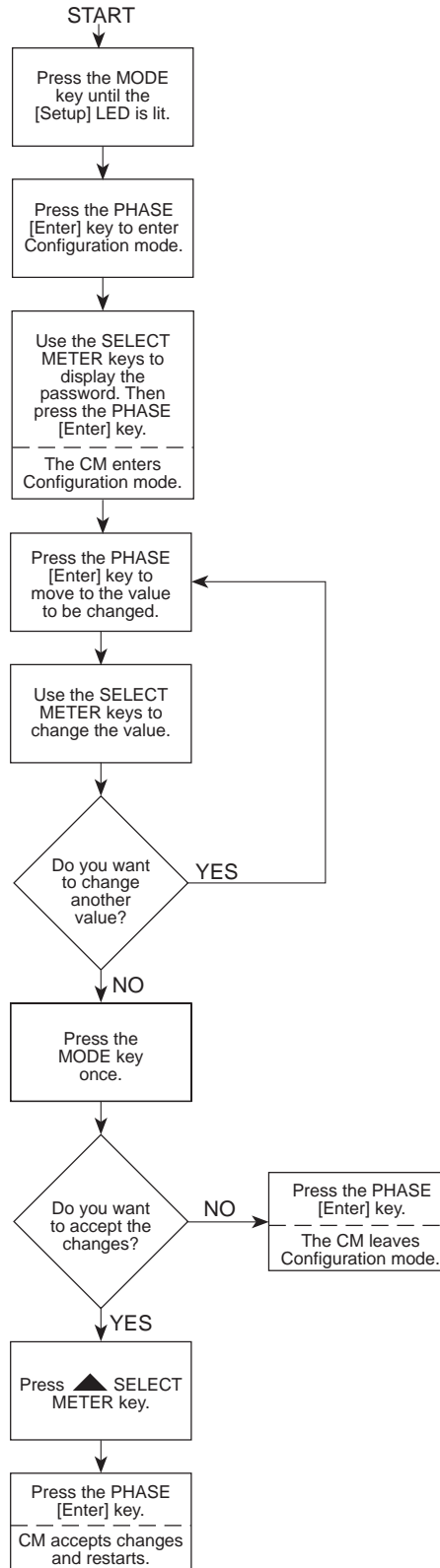

Figure 4-2: Flowchart for front panel configuration

**Viewing Configuration Data
In Protected Mode**

The circuit monitor provides a special protected viewing mode that lets you view, but not change, configuration data.

To view configuration data, complete the following steps:

1. Press the MODE button until the red LED next to [Setup] is lit.

The circuit monitor displays “ConFig”.

2. Press the PHASE [Enter] button.

The circuit monitor displays the password prompt “P - - - -.”

3. Enter 9999 for the password.

To enter 9999, use the SELECT METER [Value] buttons to decrease the displayed value until it reaches 9999. Then press the PHASE [Enter] button.

The circuit monitor enters the protected viewing mode and scrolls through the following device information:

- d=2350 (the number after “d=” represents the device model number)
- s=0345 (the numbers following “s=” represent the last four digits of the device serial number)
- r=1516 (the first two digits after “r=” represent the reset code revision and the last two digits represent the circuit monitor firmware revision level)
- 1=001 (the digits following “1=” represent the circuit monitor firmware sub-revision level, as in firmware version 17.002)

After this scrolling sequence, the display shows the present CT ratio.

4. Press the PHASE [Enter] button to move from one configuration item to the next.

5. To exit the protected viewing mode, press the MODE button.

The circuit monitor returns to METERS mode.

Setting the Master Password

The circuit monitor's four setup modes are password protected. A *master password* can be used to access any of the four setup modes. In addition to the master password, the circuit monitor provides a *reset password*. The reset password provides access to the Resets option only. Until you define a unique reset password, the reset password defaults to the master password. For instructions on defining and using the reset password see **Performing Resets Using the Resets Option** in this chapter.

The master password can be any value in the range 0 to 9998. The factory default is 0.

To change the master password, complete the following steps:

1. Press the MODE button until the red LED next to [Setup] is lit.
The circuit monitor displays "ConFig."
2. Press the PHASE [Enter] button to select the Configuration option.
The circuit monitor displays the password prompt "P - - - -."
3. Enter the existing master password.
To enter the password, use the SELECT METER [Value] buttons to increase or decrease the displayed value until it reaches the password value. Then press the PHASE [Enter] button. (The circuit monitor's default password is 0.)
4. Press the PHASE [Enter] button until the red LED next to [Set Password] flashes.
5. Press the SELECT METER [Value] buttons until the desired password value is displayed.
The password can be any value from 0 to 9998.
6. Press the MODE button once.
The red LED next to [Accept] flashes. The red LED next to [Set Password] glows steadily.
7. To reject the new password, press the PHASE [Enter] button once.
The circuit monitor returns to METERS mode.
8. To accept the new password, press the up arrow SELECT METER [Value] button to change from *No* to *Yes*. Then, press the PHASE [Enter] button.
The circuit monitor returns to METERS mode.

Setting the CT Ratios

The circuit monitor supports two primary CT ratings: one for the phase CTs and one for the neutral CT. The allowable range is 1 to 32,767. The factory default for both CT secondaries is 5.

Note: The neutral CT is optional. If the circuit monitor is set up for any system type that does not require a neutral CT, the circuit monitor ignores the neutral CT rating (even if neutral currents are reported).

To change the primary CT ratings, complete the following steps:

1. Press the MODE button until the red LED next to [Setup] is lit.
The circuit monitor displays “ConFig”.
2. Press the PHASE [Enter] button to select the Configuration option.
The circuit monitor displays the password prompt “P - - - -.”
3. Enter the master password.
To enter the password, use the SELECT METER [Value] buttons to increase or decrease the displayed value until it reaches the password value. Then press the PHASE [Enter] button.
The red LED next to [CT Primary] flashes indicating that the circuit monitor is in Configuration mode. The 3-PHASE LED also lights indicating that the circuit monitor is displaying the 3-phase, primary CT rating.
4. Press the SELECT METER [Value] buttons until the desired 3-phase, primary CT rating is displayed.
5. Press the PHASE [Enter] button once.
The N (Neutral) phase LED lights, and the circuit monitor displays the primary CT rating for the neutral CT.
6. Press the SELECT METER [Value] buttons until the desired neutral primary CT rating is displayed.
7. Press the MODE button once.
The red LED next to [Accept] flashes. The red LED next to [CT Primary] glows steadily.
8. To reject the new CT rating(s), press the PHASE [Enter] button once.
The circuit monitor returns to METERS mode.
9. To accept the new CT rating(s), press the UP ARROW SELECT METER [Value] button to change from *No* to *Yes*. Then, press the PHASE [Enter] button.
The circuit monitor restarts.

Setting the PT Ratio

The circuit monitor supports one primary PT rating. The allowable range is 1 to 1,700,000 volts. The factory default PT secondary is 120 V.

To change the primary PT rating, complete the following steps:

1. Press the MODE button until the red LED next to [Setup] is lit.
The circuit monitor displays "ConFig".
2. Press the PHASE [Enter] button to select the Configuration option.
The circuit monitor displays the password prompt "P - - - -."
3. Enter the master password.
To enter the password, use the SELECT METER [Value] buttons to increase or decrease the displayed value until it reaches the password value. Then press the PHASE [Enter] button.
3. Press the PHASE [Enter] button twice.
The red LED next to the [PT Primary] item flashes. The 3-PHASE LED lights, and the circuit monitor displays the primary PT rating for the 3-Phase PTs.
4. Press the SELECT METER [Value] buttons until the desired primary PT rating is displayed.
5. Press the MODE button once.
The red LED next to [Accept] flashes. The red LED next to [PT Primary] glows steadily.
6. To reject the new PT rating, press the PHASE [Enter] button once.
The circuit monitor returns to METERS mode.
7. To accept the new PT rating, press the up arrow SELECT METER [Value] button to change from *No* to *Yes*. Then, press the PHASE [Enter] button.

Setting the System Type

For the circuit monitor to meter correctly, you must specify the system connection type. The circuit monitor supports three system wiring connections. Table 4-2 shows the system connection types. The factory default is 40.

Table 4-2
Supported System Type System Code Selections

System Type	# Phase CTs	Aux CT	# PTs	PT Conn.	System Code
3 \emptyset , 3-wire Delta	2	None	2	Open Delta	30
3 \emptyset , 4-wire Wye, Grounded	3	None	3	Wye-Wye	40
3 \emptyset , 4-wire Wye, Grounded	3	1 (Neut)	3	Wye-Wye	41
3 \emptyset , 4-wire Wye, Grounded	3	None	2	Open Wye	42
3 \emptyset , 4-wire Wye, Grounded	3	1 (Neut)	2	Open Wye	43

To change the system type, complete the following steps:

1. Press the MODE button until the red LED next to [Setup] is lit.
The circuit monitor displays “ConFig.”
2. Press the PHASE [Enter] button to select the Configuration option.
The circuit monitor displays the password prompt “P - - - -.”
3. Enter the password.
To enter the password, use the SELECT METER [Value] buttons to increase or decrease the displayed value until it reaches the password value. Then press the PHASE [Enter] button.
4. Press the PHASE [Enter] button until the red LED next to [Sys. Type] flashes.
5. Press the SELECT METER [Value] buttons until the system code matching your system type is displayed.
Refer to table 4-2 to determine the system code for your system type.
6. Press the MODE button once.
The red LED next to [Accept] flashes. The red LED next to [Sys. Type] glows steadily.
7. To reject the new system type, press the PHASE [Enter] button once.
The circuit monitor returns to METERS mode.
8. To accept the new system type, press the SELECT METER [Value] button to change from *No* to *Yes*. Then, press the PHASE [Enter] button.
The circuit monitor restarts.

Setting the Demand Interval

The circuit monitor supports several methods to calculate average demand real power. The default method is the thermal demand method. For a description of available demand calculation methods, see **Demand Readings** in the *Circuit Monitor Reference Manual*.

One optional method is the demand synch pulse input method. In this method, the circuit monitor accepts an external synch pulse from another demand meter. The circuit monitor then uses the same time interval as the other meter for each demand calculation. For a more detailed description of the demand synch pulse input method, see **Demand Synch Pulse Input** in the *Circuit Monitor Reference Manual*.

Note: The circuit monitor must be equipped with an input/output module to use the Demand Synch Pulse Input feature.

The thermal demand (default) method and the demand synch pulse input method can be set up from the circuit monitor front panel. Other methods must be set up over the communications link, or using the front panel diagnostics feature (see **Reading and Writing Registers from the Front Panel** in the *Circuit Monitor Reference Manual* for instructions on using this feature).

Setting the Demand Interval (cont.)

To set up the circuit monitor for the default thermal demand method, complete the procedure below—entering a demand interval from 5 to 60 minutes (the factory default is 15). To set up the circuit monitor for the demand synch pulse input method, follow the procedure below and set the demand interval to 0 minutes.

To change the demand interval, complete the following steps:

1. Press the MODE button until the red LED next to [Setup] is lit.
The circuit monitor displays “ConFig.”
2. Press the PHASE [Enter] button to select the Configuration option.
The circuit monitor displays the password prompt “P - - - -.”
3. Enter the password.
To enter the password, use the SELECT METER [Value] buttons to increase or decrease the displayed value until it reaches the password value. Then press the PHASE [Enter] button.
4. Press the PHASE [Enter] button until the red LED next to [Dmd. Int.] flashes.
5. Press the SELECT METER [Value] buttons until the desired demand interval is displayed.
Select 0 for the demand synch pulse input method.
6. Press the MODE button once.
The red LED next to [Accept] flashes. The red LED next to [Dmd. Int.] glows steadily.
7. To reject the new demand interval, press the PHASE [Enter] button.
The circuit monitor returns to METERS mode.
8. To accept the new demand interval, press the SELECT METER [Value] button to change from *No* to *Yes*. Then, press the PHASE [Enter] button.
The circuit monitor restarts.

Setting the Watthour/ Pulse Output

The allowable range for the watthours-per-pulse output is 0 to 3,276.7 kWh. The watthours per pulse can be set in one-tenth kWh increments, generating a pulse as often as every 0.1 kWh (not to exceed 10 pulses per second), or as seldom as every 3276.0 kWh. Setting the watthours per pulse to 0 disables the pulse. The factory default is 0.

*Note: The circuit monitor must be equipped with an input/output module to use this feature. For a more detailed description of the watthour pulse output feature, see **Solid-State KYZ Pulse Output** in the **Circuit Monitor Reference Manual**.*

To change the Watthour/Pulse output, complete the following steps:

1. Press the MODE button until the red LED next to [Setup] is lit.
The circuit monitor displays "ConFig."
2. Press the PHASE [Enter] button to select the Configuration option.
The circuit monitor displays the password prompt "P - - - -."
3. Enter the password.
To enter the password, use the SELECT METER [Value] buttons to increase or decrease the displayed value until it reaches the password value. Then press the PHASE [Enter] button.
4. Press the PHASE [Enter] button until the red LED next to [WH/Pulse] flashes.
5. Press the SELECT METER [Value] buttons until the desired kilowatthours per pulse value is displayed.
6. Press the MODE button once.
The red LED next to [Accept] flashes. The red LED next to [WH/Pulse] glows steadily.
7. To reject the new pulse interval, press the PHASE [Enter] button once.
The circuit monitor returns to METERS mode.
8. To accept the new pulse interval, press the SELECT METER [Value] button to change from *No* to *Yes*. Then, press the PHASE [Enter] button.
The circuit monitor restarts.

Setting the Device Address

Each POWERLOGIC device on a communications link must have a *unique* device address. (The term *communications link* refers to 1-32 POWERLOGIC compatible devices daisy-chained to a single communications port.) The allowable range of addresses is 1 to 198. The factory default address is 1. (The circuit monitor will actually accept address 199, but address 199 is a special reserved address and we recommend that you not use it.)

Note: By networking groups of devices, POWERLOGIC systems can support a virtually unlimited number of devices.

When addressing POWERLOGIC devices, remember the following points:

- Each device on a single communications link—including the PNIM or SY/LINK card—must be assigned a *unique* address.
- Normally, the last device on a communications link—the device farthest from the communications port—should be assigned device address 1.
- If a communications link has only a single device, assign it address 1.
- If you add devices to the communications link, the last device should retain the address 1.

To change the device address, complete the following steps:

1. Press the MODE button until the red LED next to [Setup] is lit.
The circuit monitor displays "ConFig."
2. Press the PHASE [Enter] button to select the Configuration option.
The circuit monitor displays the password prompt "P - - - -."
3. Enter the password.
To enter the password, use the SELECT METER [Value] buttons to increase or decrease the displayed value until it reaches the password value. Then press the PHASE [Enter] button.
4. Press the PHASE [Enter] button until the red LED next to [Address] flashes.
5. Press the SELECT METER [Value] buttons until the desired address is displayed.
6. Press the MODE button once.
The red LED next to [Accept] flashes. The red LED next to [Address] glows steadily.
7. To reject the new address, press the PHASE [Enter] button once.
The circuit monitor returns to METERS mode.
8. To accept the new address, press the SELECT METER [Value] button to change from *No* to *Yes*. Then, press the PHASE [Enter] button.
The circuit monitor restarts.

Setting the Baud Rate

Set the circuit monitor's baud rate to match the baud rate of all other devices on the communications link. The available baud rates are 1200, 2400, 4800, 9600, and 19200. The factory default is 9600 bps.

The maximum baud rate may be limited by the number of devices and total length of the communications link. Table 4-3 shows distance restrictions at varying baud rates.

To change the baud rate, complete the following steps:

1. Press the MODE button until the red LED next to [Setup] is lit.
The circuit monitor displays "ConFig."
2. Press the PHASE [Enter] button to select the Configuration option.
The circuit monitor displays the password prompt "P - - - -."
3. Enter the password.
To enter the password, use the SELECT METER [Value] buttons to increase or decrease the displayed value until it reaches the password value. Then press the PHASE [Enter] button.
4. Press the PHASE [Enter] button until the red LED next to [Baud Rate] flashes.
5. Press the SELECT METER [Value] buttons until the desired baud rate is displayed.
6. Press the MODE button once.
The red LED next to [Accept] flashes. The red LED next to [Baud Rate] glows steadily.
7. To reject the new baud rate, press the PHASE [Enter] button once.
The circuit monitor returns to METERS mode.
8. To accept the new baud rate, press the SELECT METER [Value] button once to change from *No* to *Yes*. Then, press the PHASE [Enter] button.
The circuit monitor restarts.

Table 4-3
Maximum Distances of Comms Link at Varying Baud Rates

Baud Rate (bps)	Maximum Distances	
	1–16 devices	17–32 devices
1200	10,000 ft (3,050 m)	10,000 ft (3,050 m)
2400	10,000 ft (3,050 m)	5,000 ft (1,525 m)
4800	10,000 ft (3,050 m)	5,000 ft (1,525 m)
9600	10,000 ft (3,050 m)	4,000 ft (1,220 m)
19200	10,000 ft (3,050 m)	2,500 ft (762.5 m)

Setting the Nominal Frequency

The circuit monitor supports three nominal frequencies: 50 Hz, 60 Hz, and 400 Hz. The factory default is 60 Hz.

To change the nominal frequency, complete the following steps:

1. Press the MODE button until the red LED next to [Setup] is lit.
The circuit monitor displays "ConFig."
2. Press the PHASE [Enter] button to select the Configuration option.
The circuit monitor displays the password prompt "P - - - -."
3. Enter the password.
To enter the password, use the SELECT METER [Value] buttons to increase or decrease the displayed value until it reaches the password value. Then press the PHASE [Enter] button.
4. Press the PHASE [Enter] button until the red LED next to [Nom. Freq.] flashes.
5. Press the SELECT METER [Value] buttons until the desired frequency is displayed.
6. Press the MODE button once.
The red LED next to [Accept] flashes. The red LED next to [Nom. Freq.] glows steadily.
7. To reject the new nominal frequency, press the PHASE [Enter] button once.
The circuit monitor returns to METERS mode.
8. To accept the new nominal frequency, press the SELECT METER [Value] button once to change from *No* to *Yes*. Then, press the PHASE [Enter] button.
The circuit monitor restarts.

Note: *If the circuit monitor cannot measure a valid frequency, it uses the nominal frequency to perform metering calculations. For example, with no voltage present, the circuit monitor will meter amps using the nominal frequency in place of the missing measured frequency. Some metered values—such as THD and K-Factor—require a valid frequency. When a valid frequency cannot be measured, the circuit monitor displays dashes in place of values.*

Resetting Demand, Energy, and Min./Max. Values

The following values can be reset from the circuit monitor front panel: Demand Ammeter (A), Demand Power (W), Demand Power (VA), Watthour Meter, Varhour Meter, and Minimums and Maximums.

Demand Power (W) and Demand Power (VA) are reset together; you cannot reset one without resetting the other. Likewise, the Watthour Meter and Varhour Meter are reset together.

*Note: You can also reset energy, demand, and min/max values using the Resets option. The Resets option lets you perform resets but not change configuration values. See **Performing Resets Using the Resets Option** on the next page for more information.*

To reset data, complete the following steps:

1. Press the MODE button until the red LED next to [Setup] is lit.
The circuit monitor displays “ConFig.”
2. Press the PHASE [Enter] button to select the Configuration option.
The circuit monitor displays the password prompt “P - - - -.”
3. Enter the password.
To enter the password, use the SELECT METER [Value] buttons to increase or decrease the displayed value until it reaches the password value. Then press the PHASE [Enter] button.
4. Press the PHASE [Enter] button until the red LED next to the desired reset item flashes.
Remember, if you choose Demand Power (W), the LED for Demand Power (VA) also lights, and vice versa. Likewise, if you choose Watthour Meter, the LED for Varhour Meter also lights, and vice versa.
5. Press the up arrow SELECT METER [Value] button to change the circuit monitor display from *No* to *Yes*.
6. Repeat steps 4 and 5 until you’ve said *Yes* to all items to be reset.
7. Press the MODE button once.
The red LED next to [Accept] flashes. The red LEDs next to the selected reset items glow steadily.
8. To cancel the reset(s), press the PHASE [Enter] button once.
The circuit monitor display flashes and the circuit monitor returns to METERS mode.
9. To perform the reset(s), press the SELECT METER [Value] button once to change from *No* to *Yes*. Then, press the PHASE [Enter] button.
The circuit monitor performs the resets and returns to METERS mode.

PERFORMING RESETS USING THE RESETS OPTION

The Resets option lets you reset energy, demand, and min/max values. The same reset operations can be done using the Configuration option (described on the previous page). The difference is that using the Resets option, you can perform resets only—you cannot change configuration values.

The Resets option is password protected. To access the Resets option, you must enter either the master password, or a special reset password. (See **Setting the Master Password** in this chapter for instructions on defining the master password.)

The reset password can be used to prevent accidental changes to configuration values. For example, you could provide an operator with the reset password only, allowing the operator to perform resets, but not change configuration values.

The reset password defaults to the master password. The circuit monitor's factory default master password is 0. Therefore, when you receive a new circuit monitor, its reset password is also 0. When you change the master password, the reset password changes to match it. To define a reset password different than the master password, you must write a unique value—in the range 1–9998—to circuit monitor register 2031. You can write to register 2031 in one of two ways:

- From a remote PC, using POWERLOGIC application software. (Refer to the software instruction manual for specific instructions on writing to circuit monitor registers.)
- From the front panel of the circuit monitor, using the Diagnostics option. (See **Reading and Writing Registers from the Front Panel** in the *Circuit Monitor Reference Manual* for instructions on reading and writing registers using the Diagnostics option.)

Important: After you've defined a reset password, you can access the Resets option using either the reset password *or* the master password.

To perform resets using the Resets option, refer to figure 4-3 and complete the following steps:

1. Press the MODE button until the red LED next to [Setup] is lit.
The circuit monitor displays "ConFig."
2. Press the down arrow SELECT METER button once.
The circuit monitor displays "rESETS."
3. Press the PHASE [Enter] button to select the Resets option.
The circuit monitor displays the password prompt "P - - - -."
4. Enter either the master password or the reset password.
To enter a password, use the SELECT METER [Value] buttons to increase or decrease the displayed value until it reaches the password value. Then press the PHASE [Enter] button.
5. Follow steps 4–9 of the reset procedure described on the previous page.

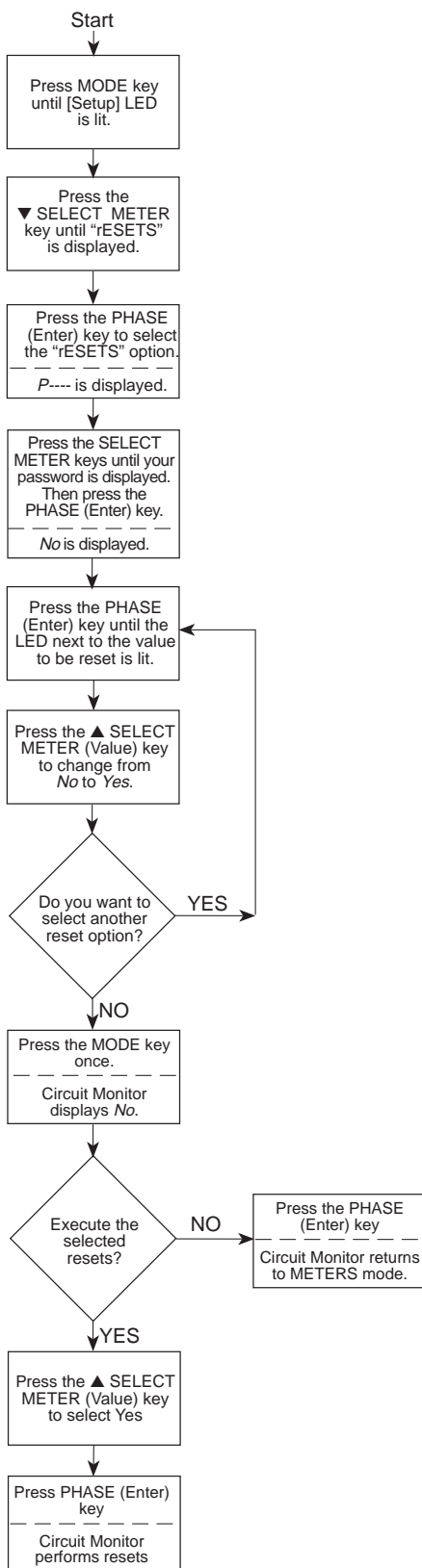

Figure 4-3: Flowchart for performing resets using the Resets option

SETTING UP ALARM/RELAY FUNCTIONS

The circuit monitor (models CM-2150 and higher) can detect over 100 alarm conditions, including over/under conditions, status input changes, phase unbalance conditions, and more. (See **Alarm Conditions and Alarm Codes** in the *Circuit Monitor Reference Manual* for a complete listing.)

Each alarm condition can be set up to automatically operate one or more circuit monitor relays. Also, multiple alarm conditions can be assigned to operate the same relay(s). For a description of the circuit monitor's alarm/relay functions, see **Alarm Functions** in the *Circuit Monitor Reference Manual*.

If you do not have POWERLOGIC application software, you can set up the circuit monitor's on-board alarm/relay functions from the circuit monitor's front panel. Perform this set up using the Alarm/Relay (AL.rLY) option, one of the circuit monitor's four setup options. For each alarm condition you can:

- Enable or disable the alarm condition
- Assign a priority level to the alarm condition
- Define any required pickup and dropout setpoints, and pickup and dropout time delays
- Set up the circuit monitor to operate up to three relay outputs when the alarm condition occurs

The circuit monitor's relay outputs provide ten operating modes. (See **Relay Output Operating Modes** in the *Circuit Monitor Reference Manual* for descriptions of the modes.) When you assign an alarm condition to operate a relay from the front panel of the circuit monitor, the circuit monitor configures the relay to operate in Normal mode. If Normal mode is not acceptable, you'll need to do one of the following:

- Set up the circuit monitor's alarm/relay functions over the communications link, using POWERLOGIC application software (which lets you choose from the 10 available modes)
- First set up the alarm/relay functions from the circuit monitor's front panel, then change the relay's operating mode by performing register read/writes using either POWERLOGIC application software or the circuit monitor's Diagnostics option (see **Reading and Writing Registers from the Front Panel** in the *Circuit Monitor Reference Manual* for instructions on reading and writing registers using the Diagnostics option)

General Setup Procedure

The procedure below describes the general steps required to set up alarm/relay functions. Figure 4-4 illustrates the procedure. For detailed steps, see **Detailed Setup Procedure** on the following page.

The general steps required to set up alarm/relay functions are:

1. Enter [Setup] Mode.
2. Choose the Alarm/Relay (AL.rLy) option.
3. Select an alarm number to configure. (See **Alarm Setup Information** in the *Circuit Monitor Reference Manual* for a list of alarm numbers.)
4. Define the required alarm/relay configuration items (priority level, pickup setpoint, pickup delay, and so on).
5. Accept or reject the changes just made.
6. Repeat steps 3–5 until you’ve configured all desired alarms.
7. Exit to Meters mode.

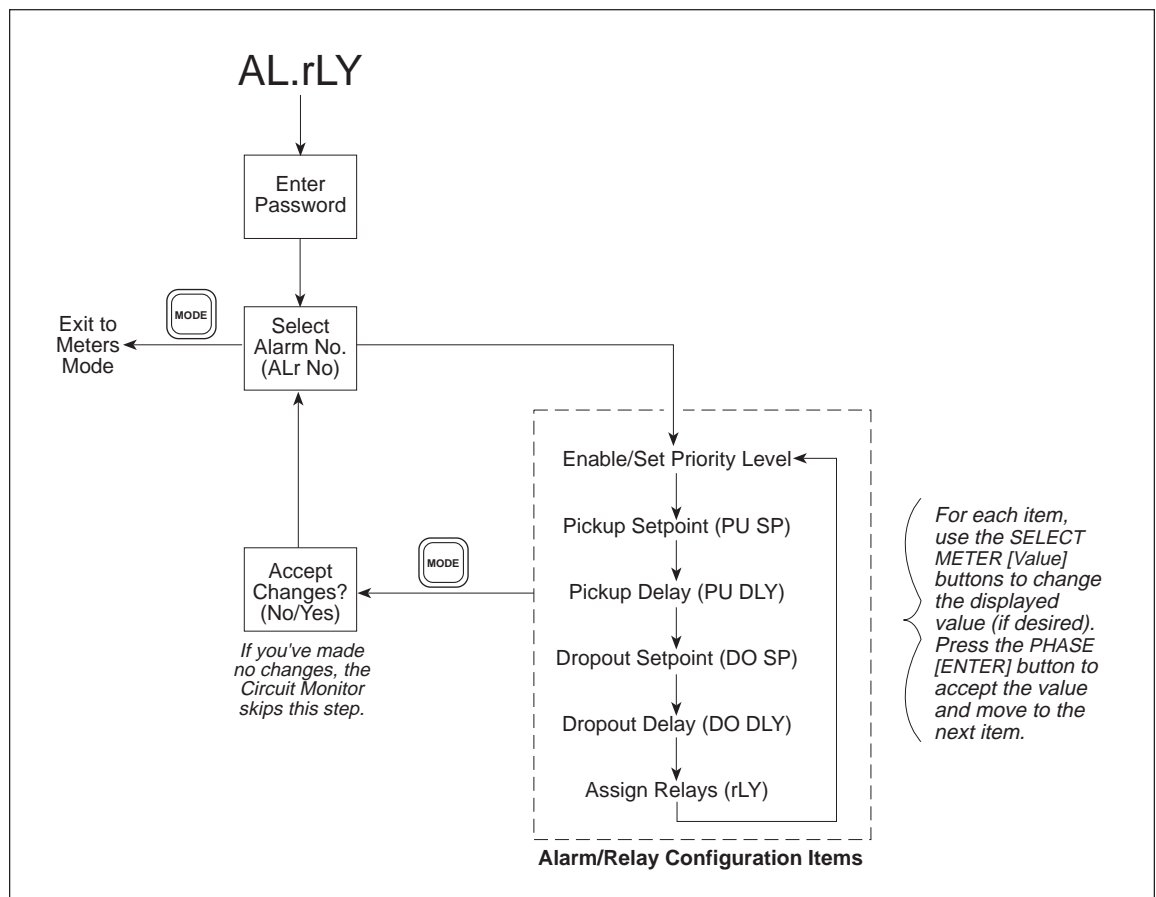

Figure 4-4: Alarm/Relay setup

Detailed Setup Procedure

This section offers detailed steps on how to set up alarm/relay functions from the front panel. Figure 4-4 illustrates the general flow of the setup procedure.

To set up alarm/relay functions, complete the following steps:

1. Press the MODE button until the red LED next to [Setup] is lit.
The circuit monitor displays "ConFig."
2. Press the down arrow SELECT METER button until the Circuit Monitor displays "AL.rLy."
3. Press the PHASE [Enter] button to select the Alarm/Relay option.
The circuit monitor displays the password prompt "P - - - -."
4. Enter the master password.
To enter the password, use the SELECT METER [Value] buttons to increase or decrease the displayed value until it reaches the password value. Then press the PHASE [Enter] button.
The display alternates between "ALr No" (an abbreviation for alarm number) and "1". Appendix I shows that alarm number 1 corresponds to the alarm condition "Over Current Phase A." Refer to **Alarm Setup Information** in the *Circuit Monitor Reference Manual* while setting up alarm/relay functions.
5. Use the SELECT METER [Value] buttons to increase or decrease the displayed alarm number until you reach the desired number.
The circuit monitor display stops alternating while you change the alarm number. If an alarm condition is enabled, the circuit monitor displays the alarm condition's priority to the left of the alarm number. For example, if you had previously enabled alarm number 1 and assigned it priority 0, the circuit monitor would display "P0 1".
6. Press the PHASE [Enter] button to select the alarm number.
If you have not previously enabled this alarm condition, the display alternates between "ENABLE" and "OFF." If you've previously enabled this alarm condition, the display alternates between "ENABLE" and the chosen alarm priority (P0, P1, P2, or P3).
7. To enable the selected alarm condition, and to assign the alarm condition a priority level, press the down arrow SELECT METER [Value] button until the desired priority level is displayed.

Note: Using POWERLOGIC software, you can assign one or more of the following actions for each alarm condition. The circuit monitor performs the assigned actions each time the alarm condition occurs, no matter what the priority level.

- Operate one or more relay outputs
- Force data log entries into 1-14 user-defined data log files
- Perform a 4-cycle waveform capture
- Perform a 12-cycle event capture

**Detailed Setup Procedure
(cont.)**

You must assign these actions to alarm conditions using POWERLOGIC software.

Depending on the chosen priority level, the circuit monitor also performs the actions described below.

P0—No priority. On the occurrence of a P0 alarm, the circuit monitor does the following:

- Performs any assigned actions

P1—Highest priority level. On the occurrence of a P1 alarm, the circuit monitor does the following:

- Puts the alarm number in the list of active alarms, accessible from the front panel (see **Viewing Active Alarms** in the *Circuit Monitor Reference Manual* for instructions on viewing active alarms)
- Records the occurrence in the circuit monitor's event log file
- Enters the alarm number in the P1 log, accessible from the front panel (see **Viewing the Priority 1 Log** in the *Circuit Monitor Reference Manual* for a instructions on viewing the P1 log)
- Performs any assigned actions

P2—Middle priority level. On the occurrence of a P2 alarm, the circuit monitor does the following:

- Puts the alarm number in the list of active alarms, accessible from the front panel (see **Viewing Active Alarms** in the *Circuit Monitor Reference Manual* for instructions on viewing active alarms)
- Records the alarm occurrence in the circuit monitor's event log file
- Performs any assigned actions

P3—Lowest priority level. On the occurrence of a P3 alarm, the circuit monitor does the following:

- Puts the alarm number in the list of active alarms, accessible from the front panel (see **Viewing Active Alarms** in the *Circuit Monitor Reference Manual* for instructions on viewing active alarms)
- Records the alarm occurrence in the circuit monitor's event log file
- Performs any assigned actions

8. Press the PHASE [Enter] button to select the priority level.

The display alternates between "PU SP" (an abbreviation for pickup setpoint) and the setpoint value.

9. Use the SELECT METER [Value] buttons to increase or decrease the displayed value until you reach the desired pickup setpoint.

See **Setpoint-Driven Alarms** in the *Circuit Monitor Reference Manual* for a description of pickup and dropout setpoint and time delays.

If you are configuring an alarm condition that does not require some or all of the pickup and dropout setpoints and delays, for example status

**Detailed Setup Procedure
(cont.)**

input transition alarm conditions, the circuit monitor allows you to enter setpoints and delays, but it ignores any values that don't apply.

10. Press the PHASE [Enter] button.

The display alternates between "PU dLy" (an abbreviation for pickup delay) and the delay value.

11. Use the SELECT METER [Value] buttons to increase or decrease the displayed value until you reach the desired pickup delay (in seconds).

12. Press the PHASE [Enter] button.

The circuit monitor display alternates between "do SP" (an abbreviation for dropout setpoint) and the setpoint value.

13. Use the SELECT METER [Value] buttons to increase or decrease the displayed value until you reach the desired dropout setpoint.

14. Press the PHASE [Enter] button.

The display alternates between "do dLy" (an abbreviation for dropout delay) and the delay value.

15. Use the SELECT METER [Value] buttons to increase or decrease the displayed value until you reach the desired dropout delay (in seconds).

16. Press the PHASE [Enter] button.

The circuit monitor displays "r1 No". "r1" stands for relay 1.

17. If you want the circuit monitor to operate relay R1 each time the alarm condition occurs, press the up arrow SELECT METER [Value] button to change from "No" to "Yes." Then press the PHASE [Enter] button.

The circuit monitor displays "r2 No".

18. If you want the circuit monitor to operate relay R2 each time the alarm condition occurs, press the up arrow SELECT METER [Value] button to change from "No" to "Yes." Then press the PHASE [Enter] button.

The circuit monitor displays "r3 No".

19. If you want the circuit monitor to operate relay R3 each time the alarm condition occurs, press the up arrow SELECT METER [Value] button to change from "No" to "Yes." Then press the PHASE [Enter] button.

The display alternates between "ENABLE" and the priority level.

20. Press the MODE button.

The circuit monitor displays "No."

21. To save the configuration changes you just made, press the up arrow SELECT METER [Value] button to change from "No" to "Yes." Then press the PHASE [Enter] button. To discard the changes, press the PHASE [Enter] button.

The circuit monitor displays the alarm number. At this point you've completed the configuration process for one alarm condition.

**Detailed Setup Procedure
(cont.)**

22. Repeat steps 5-21 above for each additional alarm condition that you'd like to configure.
23. To leave the Alarm/Relay setup option, press the MODE button while the circuit monitor is displaying the "ALr No" prompt.

The circuit monitor returns to METERS mode.

VIEWING ACTIVE ALARMS

Each of the circuit monitor's alarm conditions has an associated alarm code. The alarm codes of the active alarms can be viewed from the front panel. (The alarm conditions and their associated alarm codes are listed in **Alarm Setup Information** in the *Circuit Monitor Reference Manual*.)

Note: The ALARM mode LED, on the circuit monitor's front panel, flashes while at least one of the following conditions is true: a nonzero priority alarm is active, or a priority one alarm has occurred since the last time the priority 1 log was cleared.

To view the active alarm codes, complete the following steps:

1. Press the MODE button until the red LED next to Alarm glows steadily.
The circuit monitor displays "P1.Log."
2. Press the up arrow SELECT METER [Value] button until "AL.Code" (an abbreviation for *alarm code*) is displayed.
3. Press the PHASE [Enter] button.
The circuit monitor displays the lowest active alarm code. If there are no active alarms, the circuit monitor displays *-None-*.
Each alarm code is displayed with either an "rLY" extension or an "AL" extension. If you have set up the alarm condition to operate one or more relays, the code appears with an rLY extension (for relay). If you did not set up the alarm condition to operate a relay, the code appears with an AL extension (for alarm only).
4. Press the down arrow SELECT METER [Value] button to cycle through the active alarms.

The circuit monitor displays the codes from lowest to highest.

VIEWING THE PRIORITY 1 LOG

To provide a record of high priority alarm occurrences, the circuit monitor maintains a *priority 1 log* (P1 log). See **Setting Up Alarm/Relay Functions** in this chapter for a complete description of the priority levels, and instructions on assigning priority levels from the front panel.

The P1 log stores up to 10 of the last priority 1 alarms. The log operates in a first-in-first-out (FIFO) manner. In other words, when the log is full, the oldest log entry (the *first in*) is removed to make room for the new entry.

When a priority 1 alarm occurs, the circuit monitor records it in the P1 log. The alarm remains in the P1 log until one of the following occurs: 10 new P1 alarms occur pushing it out of the log, or you manually clear the P1 log (see **Clearing the Priority 1 Log** on the next page).

Note: The ALARM mode LED, on the circuit monitor's front panel, flashes while at least one of the following conditions is true: a nonzero priority alarm is active, or a priority one alarm has occurred since the last time the priority 1 log was cleared.

You can view the P1 log from the circuit monitor's front panel. The following procedure tells how.

To view the P1 log, complete the following steps:

1. Press the MODE button until the red LED next to ALARM glows steadily.

The circuit monitor displays "P1.Log."

2. Press the PHASE [Enter] button.

The circuit monitor displays the alarm code of the lowest priority 1 alarm. If no priority 1 alarms have occurred since the P1 log was last cleared, the circuit monitor displays *-None-*.

Each alarm code is displayed with either an "rLY" extension or an "AL" extension. If you have set up the alarm condition to operate one or more relays, the code appears with an rLY extension (for relay). If you did not set up the alarm condition to operate a relay, the code appears with an AL extension (for alarm only).

4. Press the down arrow SELECT METER [Value] button to cycle through the alarm codes.

The circuit monitor displays the codes from lowest to highest.

5. To exit the P1 log but remain in the ALARM mode, press the PHASE [Enter] button. To exit the ALARM mode altogether, press the MODE button.

CLEARING THE PRIORITY 1 LOG

To provide a record of high priority alarm occurrences available for display from the front panel, the circuit monitor maintains a *priority 1 log* (P1 log). See **Setting Up Alarm/Relay Functions** in this chapter for a complete description of the priority levels, and instructions on assigning priority levels from the front panel. See **Viewing the Priority 1 Log** on the previous page for instructions on viewing the P1 log.

The P1 log stores up to 10 of the last priority 1 alarms. The log operates in a first-in-first-out (FIFO) manner. In other words, when the log is full, the first alarm entry in (the oldest) is the first out.

When a priority 1 alarm occurs, the circuit monitor records it in the P1 log. The alarm remains in the P1 log until one of the following occurs: 10 new P1 alarms occur (pushing it out of the log), or you manually clear the P1 log. The procedure below tells how to clear the P1 log.

IMPORTANT: Clearing the P1 log causes the circuit monitor to release all relays that meet the following conditions:

- The relay must be configured to operate in *latched* mode.
- The relay must be configured for internal control. In other words, you must have set up the circuit monitor to operate the relay in response to an alarm condition.
- All alarms assigned to operate the latched relay must not be in their alarm state.

To clear the P1 log, complete the following steps:

1. Press the MODE button until the red LED next to ALARM glows steadily.

The circuit monitor displays "P1.Log."

2. Press the SELECT METER [Value] buttons until "CLEAR" is displayed.

3. Press the PHASE [Enter] button.

The circuit monitor displays "CLr. No".

4. To abort the clear, press the PHASE [Enter] button.

5. To clear the log, press the up arrow SELECT METER [Value] button to change from "CLr. No" to "CLr.YES." Then press the PHASE [Enter] button.

The circuit monitor clears the P1 Log, and releases any relays that meet the conditions described above.

CHAPTER 5—MAINTENANCE AND TROUBLESHOOTING

MAINTENANCE

The circuit monitor does not require regular maintenance, nor does it contain any user-serviceable parts. If the circuit monitor requires service, contact your local Square D sales representative, or call the POWERLOGIC Technical Support Center for assistance. See **Getting Technical Support** in this chapter. *Do not open the circuit monitor. Opening the circuit monitor voids the warranty.*

Battery-Backed RAM

The circuit monitor uses battery-backed nonvolatile RAM to retain all data except calibration constants. Calibration constants are stored in nonvolatile EEPROM, which requires no battery. The circuit monitor's battery-backed RAM lasts many decades under typical operating conditions. The battery-backed RAM is activated when the circuit monitor is manufactured. With no control power applied to the circuit monitor, the battery can back up RAM for a continuous period of 7 years at 70°C. Once control power is applied, the RAM battery is no longer under load. Under no load, the life of the battery-backed RAM is 100 years at 55°C continuous, 40 years at 60°C continuous, and 10 years at 70°C continuous. Should the RAM ever need replacement, contact your Square D representative.

DANGER

HAZARD OF ELECTRIC SHOCK

Do not attempt to service the circuit monitor. CT and PT inputs may contain hazardous currents and voltages. Only authorized Square D service personnel should service the circuit monitor.

Failure to observe this precaution will result in death or serious injury.

CAUTION

HAZARD OF EQUIPMENT DAMAGE

Dielectric (Hi-Pot) testing of the circuit monitor may damage the unit. Do not Hi-Pot or Megger. Before Hi-Pot or Megger testing any equipment in which the circuit monitor is installed, disconnect all input and output wires to the circuit monitor.

Failure to observe this precaution can result in equipment damage.

TROUBLESHOOTING

This section describes three potential problems, their possible causes, and checks and/or cure for each. If, after completing the listed checks, you cannot solve the problem, contact the POWERLOGIC Technical Support Center for assistance. See **Getting Technical Support** on the next page.

PROBLEM: After applying control power to the circuit monitor, the display is still blank.

Possible Cause: The circuit monitor is not receiving the necessary power.

Check or Cure: Verify that circuit monitor L and N terminals (terminals 25 and 27) are receiving the necessary power. If you are using an optional Voltage/Power Module (VPM), check to see that the module is properly installed on the circuit monitor. Refer to your VPM instruction bulletin.

PROBLEM: The data being displayed is inaccurate or not what you expect.

Possible Cause: Incorrect setup values.

Check or Cure: Check to see that the correct values have been entered for circuit monitor setup parameters (CT and PT ratings, System Type, Nominal Frequency, and so on). See **Configuring the Circuit Monitor in Chapter 4** for setup instructions.

Possible Cause: Circuit monitor is wired improperly.

Check or Cure: Check that CTs and PTs are connected correctly (proper polarity observed) and energized. Check shorting terminals. See **Wiring CTs, PTs, and Control Power in Chapter 3** for wiring diagrams.

Possible Cause: Incorrect voltage inputs.

Check or Cure: Check circuit monitor voltage input terminals (terminals 9, 10, 11,12) to verify that adequate voltage is present.

Possible Cause: Circuit monitor is grounded incorrectly.

Check or Cure: Verify that the circuit monitor is grounded as described in **Grounding the Circuit Monitor in Chapter 3**.

Troubleshooting (cont.)

PROBLEM: Cannot communicate with circuit monitor from a remote personal computer.

Possible Cause: Circuit monitor address is incorrect.

Check or Cure: Check to see that the circuit monitor is correctly addressed. See **Setting the Device Address** in **Chapter 4** for instructions.

Possible Cause: Circuit monitor baud rate is incorrect.

Check or Cure: Verify that the baud rate of the circuit monitor matches the baud rate of all other devices on its communications link. See **Setting the Baud Rate** in **Chapter 4** for instructions.

Possible Cause: Communications lines are improperly biased.

Check or Cure: Check to see that a multipoint communications adapter is being properly used to bias the communication lines. See **Biasing the Communications Link** in **Chapter 3** for instructions.

Possible Cause: Communications lines are improperly terminated.

Check or Cure: Check to see that a multipoint communications terminator is properly installed. See **Terminating the Communications Link** in **Chapter 3** for instructions.

Possible Cause: Incorrect route statement to circuit monitor.

Check or Cure: Check route statement. Refer to the software instruction bulletin for instructions on defining route statements.

GETTING TECHNICAL SUPPORT

When you register your circuit monitor, you are entitled to 6 months of free technical phone support. If you have questions about this product, or other POWERLOGIC and POWERLINK products, contact the Power Management Operation Technical Support Center. The hours are Monday–Friday, 7:30 AM–4:30 PM (CST). The fax is available 7 days a week, 24 hours a day. If you send your fax outside of the business hours listed above, you'll receive a response on the next business day.

Phone: (615) 287-3400

Fax: (615) 287-3404

BBS: (615) 287-3414

Email: PMOSUPRT@SquareD.com

To get the most from your POWERLOGIC and POWERLINK systems, consider attending POWERLOGIC University. POWERLOGIC University offers a series of customer training courses designed to improve your skills using the POWERLOGIC and POWERLINK systems. For registration information or to request a catalog call (615) 287-3304 or fax (615) 287-3404.

APPENDIX A—CIRCUIT MONITOR DIMENSIONS

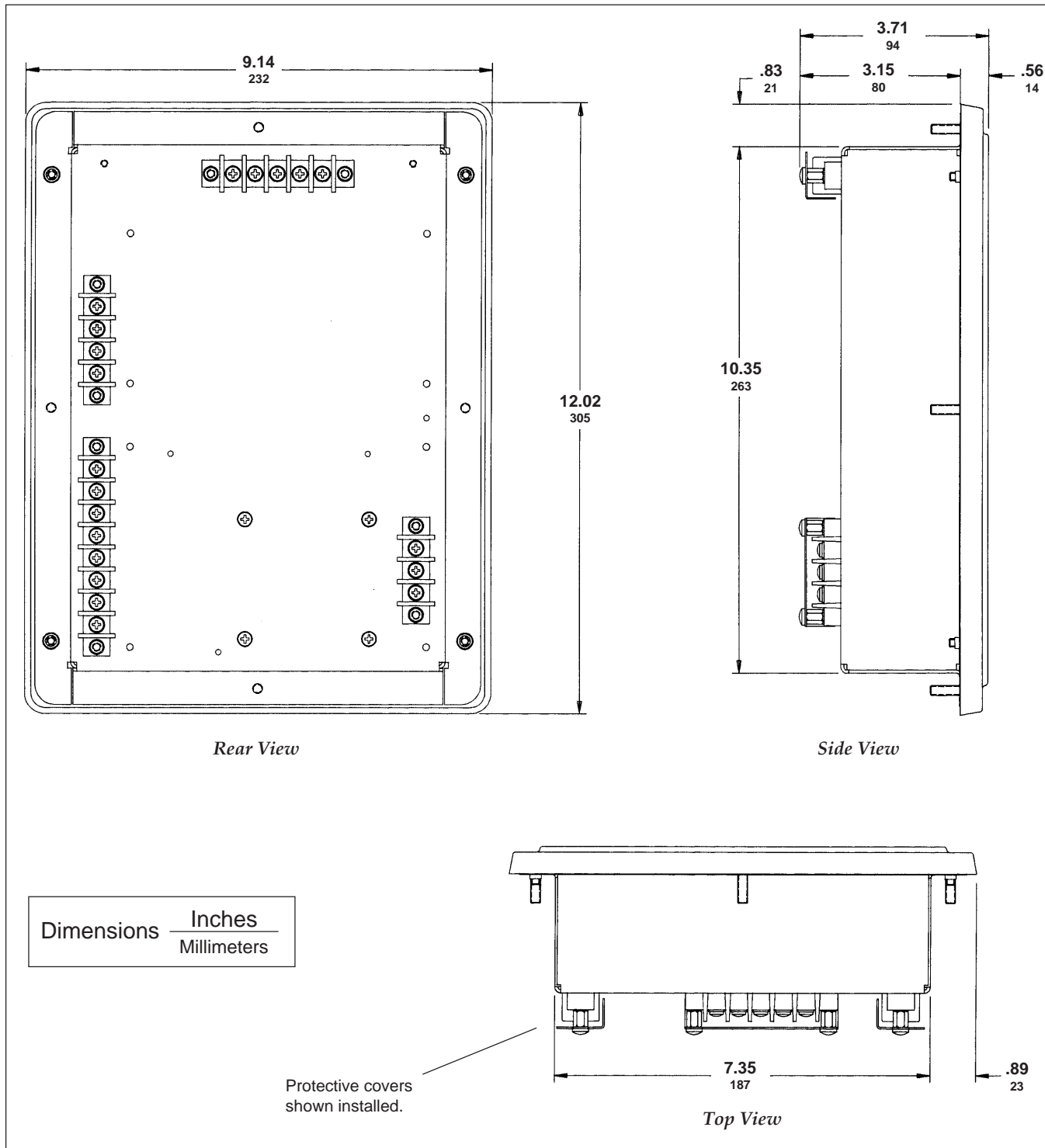

Figure A-1: Circuit monitor dimensions

APPENDIX A (cont.)

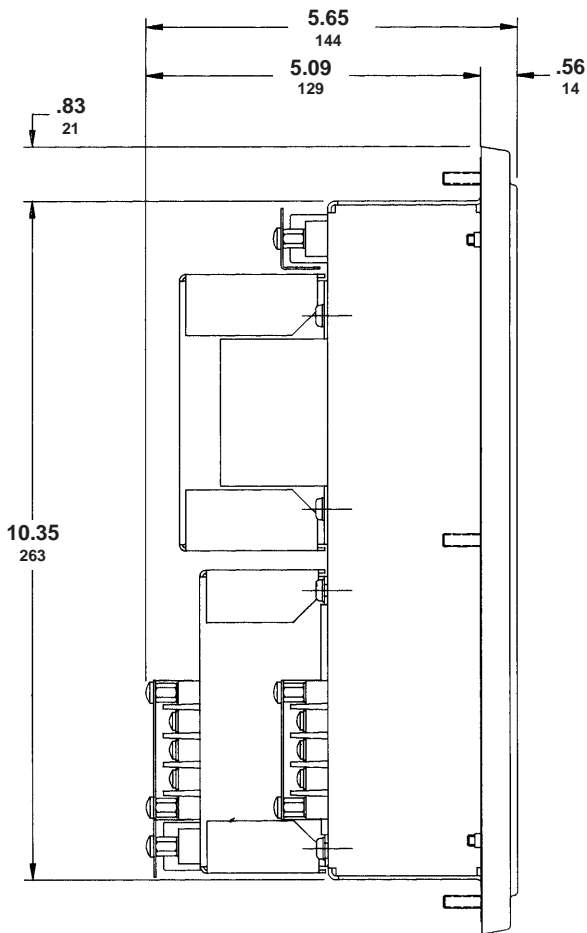

Figure A-2: Circuit monitor with Input/Output and Voltage/Power modules

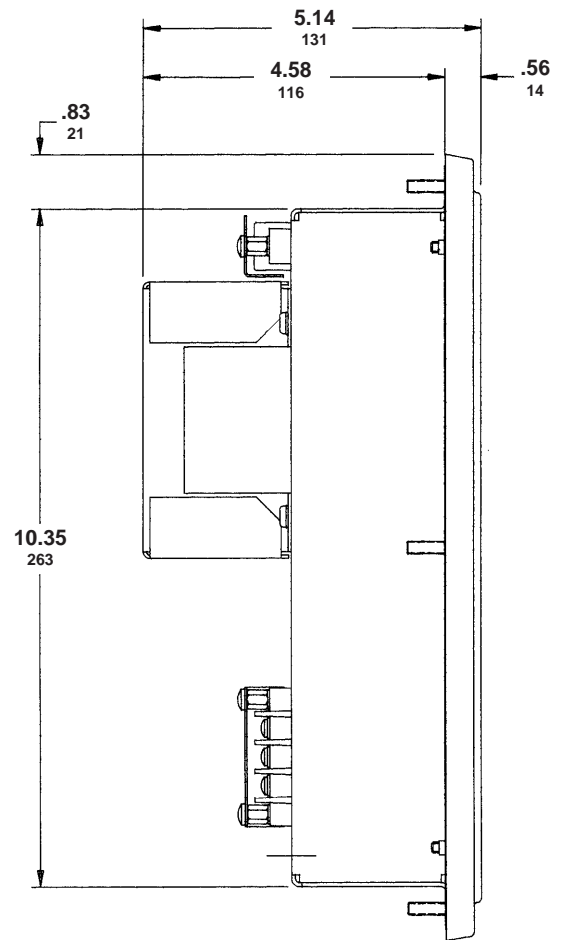

Figure A-3: Circuit monitor with Input/Output module

Dimensions	$\frac{\text{Inches}}{\text{Millimeters}}$
------------	--

APPENDIX B—SPECIFICATIONS

Metering Specifications

Current Inputs (Each Channel)

Current Range 0–7.4 A ac

Nominal Current 5 A ac

Voltage Inputs (Each Channel)

Voltage Range 0–180 Vac

Nominal Voltage (typical) 120 Vac

Frequency Range 45 to 65 Hz

..... 350 to 400 Hz

Harmonic Response—Phase Voltages and Currents

Frequency 45 Hz to 65 Hz 31st Harmonic

Data Update Rate 1 second typical

Accuracy (CM-2150 and higher)

Current^① $\pm 0.15\%$ reading + 0.05% full scale

Voltage $\pm 0.15\%$ reading + 0.05% full scale

Power $\pm 0.30\%$ reading + 0.05% full scale

True Power Factor $\pm 1\%$ (0.5 lag to 0.5 lead)

Displacement Power Factor $\pm 1\%$ (0.5 lag to 0.5 lead)

Energy $\pm 0.30\%$

Demand $\pm 0.30\%$

Frequency 50/60 Hz ± 0.01 Hz

Temperature (Unit Temperature -25°C to 75°C) $\pm 1^{\circ}\text{C}$

Time of Day Clock (At 25°C) ± 1.5 second in 24 hours

THD 1.0%

K-Factor 1.0%

Crest Factor 1.0%

Accuracy (CM-2050 only)

Current^① $\pm 0.5\%$ reading + 0.25% full scale

Voltage $\pm 0.5\%$ reading + 0.25% full scale

Power $\pm 1.0\%$ reading + 0.25% full scale

True Power Factor $\pm 1\%$ full scale

Displacement Power Factor $\pm 1\%$ full scale

Energy and Demand $\pm 0.5\%$ reading above 50% full scale

$\pm 1.0\%$ reading above 20% full scale

Frequency 50/60 Hz ± 0.05 Hz

Temperature (Unit Temperature -25°C to 75°C) $\pm 1^{\circ}\text{C}$

Time of Day Clock (At 25°C) ± 1.5 second in 24 hours

THD 2.0%

K-Factor 2.0%

Crest Factor 2.0%

^① Any CT secondary currents less than 20 mA are reported as zero.

**Metering Input
Electrical Specifications**

Current Inputs	
Nominal Full Scale	5.0 Amps rms
Metering Over-range	145%
Overcurrent Withstand	15 A rms Continuous
	50 A rms 10 seconds in 1 hour
	500 A rms 1 second in 1 hour
Input Impedance	Less than 0.1 Ohm
Burden	Less than 0.15 VA
Isolation	1500 V, 1 MIN
Voltage Inputs	
Nominal Full Scale	120 Vac Line to Neutral
Metering Over-range	150%
Dielectric Withstand	180 V Continuous
	1500 V 1 Second
Input Impedance	Greater than 2 Megohm

Control Power Input Specifications

120/240 Vac Nominal	
Operating Input Range	100–264 Vac
Burden	11 VA–15 VA
Burden, max. ^①	27 VA
Frequency Range	47 to 65 Hz
Isolation	1500 V, 1 min
Ride-through on Power Loss	0.1 sec at 120/240 Vac
125/250 Vdc Nominal	
Operating Input Range	100–300 Vdc
Burden	0.12 A
Isolation	1500 V, 1 minute
Ride-through on Power Loss	0.1 sec at 120 Vdc
Main's Supply Voltage Fluctuations	not to exceed +/-10%

Environmental Specifications

Operating Temperature	-25 to +70°C
Storage Temperature	-40 to +85°C
Humidity Rating	5–95% Relative Humidity (non-condensing) at 40°C
Pollution Degree	2
Installation Category	II
Altitude Range	0 to 4,570 m (15,000 ft.)

Physical Specifications

Weight (approximate, without add-on modules)	7 lbs
Dimensions	See Appendix A

Regulatory/Standards Compliance

Electromagnetic Interference	
Radiated	FCC Part 15 Class A
Conducted	FCC Part 15 Class A
Electrostatic Discharge (Air Discharge)	IEC 1000-4-2 Level 4
Electrical Fast Transient	IEC 1000-4-4 Level 3
Immunity to Surge	IEC 1000-4-5 Level 4
Dielectric Withstand	CSA, UL 508
Safety	CSA, UL 508
CE Marking	

^① See table 3-1, page 17, in the *Circuit Monitor Reference Manual* for burden with input/output modules present.

APPENDIX C—INSTALLING TERMINAL STRIP COVERS

The hardware kit provided with the circuit monitor includes several grey protective terminal strip covers. After wiring the circuit monitor, install these terminal strip covers for protection.

Figure F-1 illustrates terminal strip cover installation. Refer to this figure when completing the procedure below.

To install the terminal strip covers, complete the following steps:

1. Bend the terminal strip covers at the crease so they form a right angle.
2. Install each terminal strip cover using two #8-32 SEMS screws, provided in the circuit monitor hardware kit.

Be certain to orient the covers so that you can route wires outward. Wires should be routed outward to provide room for future addition of optional modules.

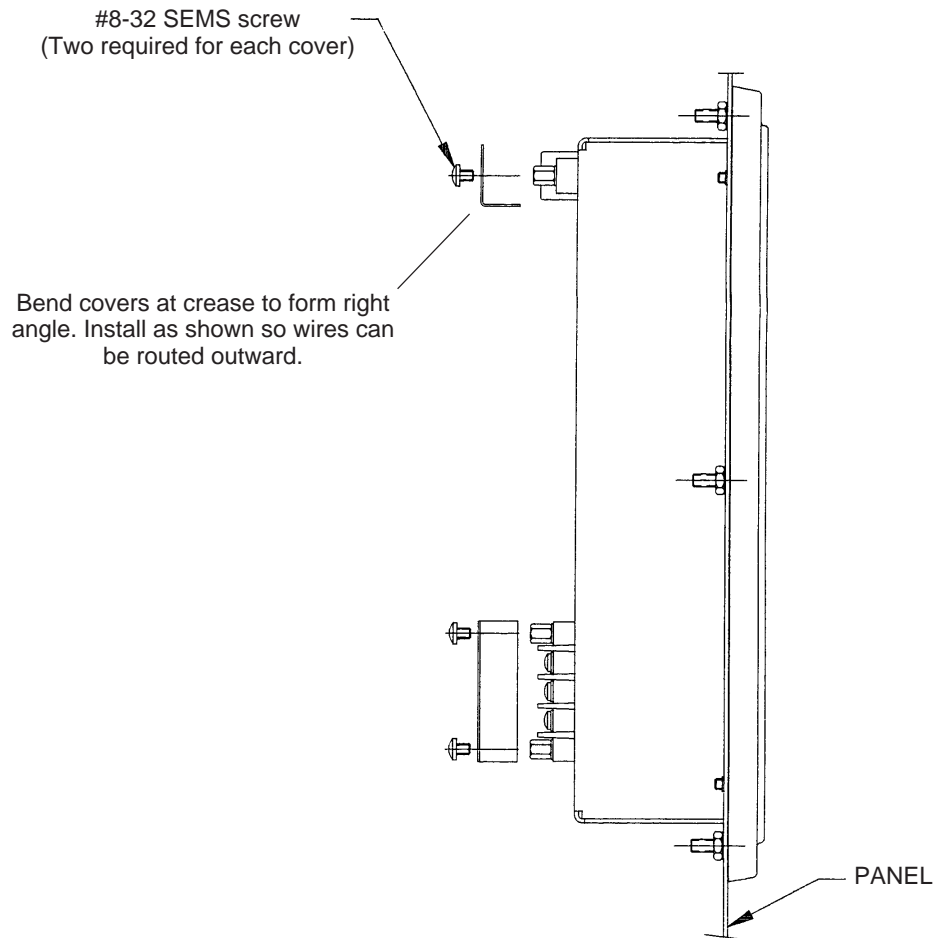

Figure C-1: Installing terminal strip covers

INDEX**A**

Alarm/relay functions 58
Alarms, viewing active 63

B

Battery-backed RAM 67
Baud rate
 max. distances of comms link 53
 setting 53
Biasing
 comms link 37
Buttons
 how they work in setup mode 41

C

CE Compliance 14
Circuit monitor
 configuration procedure 42
 configuring 42
 connections 11
 defaults 42
 description 1
 dimensions 71
 dimensions w/ I/O and VPM modules 72
 dimensions w/ I/O module 72
 feature comparison 3, 4, 5
 front panel 9
 front panel operation 39
 grounding 27
 instrumentation 3
 mounting 15
 setup, detailed 60
 setup, general 59
 types 3
Clearing the priority 1 log 65
comms link
 terminating 36
Communications
 wiring 28
Communications link
 biasing 37
 length of 34
Communications wiring
 Ethernet gateway 31
 network interface module 32
 personal computer 30

 SY/MAX programmable controller 33
 system display 29
Configuration data
 viewing in protected mode 45
Configuring
 circuit monitor 42
Control power
 deriving from phase PT inputs 26
Current Transformers (CTs)
 setting ratios 47

D

Daisy-chaining 35
Default 42
Demand, energy, and min/max values
 resetting 55
Demand interval
 setting 49
Device address
 setting 52
Dimensions 71

E

Ethernet gateway
 connecting to 31

F

Fax-On-Demand 7
Front panel operation 39

G

Getting technical support 69
Grounding
 circuit monitor 27

I

Installing terminal strip covers 75
Introduction 1

M

Maintenance 67
Maintenance and troubleshooting 67–69
Mode
 setup 40

N

Network interface module, POWERLOGIC
connecting to 32
Nominal frequency
setting 54

P

Password
setting 46
Performing resets
flowchart 57
Personal computer
connecting to 30
Phase PT inputs
deriving control power from 26
Potential Transformers (PTs)
setting ratios 48
POWERLOGIC devices
daisy-chaining 35
POWERLOGIC University 69
Priority 1 log
clearing 65
viewing 64

R

RAM, battery-backed 67
Related documents 7
Resetting demand, energy, and min/max values 55

S

Safety precautions 5, 6
Setting the baud rate 53
Setting the CT ratios 47
Setting the demand interval 49
Setting the device address 52
Setting the nominal frequency 54
Setting the password 46
Setting the PT ratio 48
Setting the watthour/pulse output 51
Setting up alarm/relay functions 58
Setup mode 40
alarm/relay 40
choosing setup option 41
configuration 40
diagnostics 40
how the buttons work 41
resets 40
Software
instruction bulletins 7

SY/MAX programmable controller
connecting to 33
System display
connecting to 29
System types 48
setting 48

T

Technical support 69
Terminal strip covers, installing 75
Terminating
comms link 36
Troubleshooting 68

V

Viewing active alarms 63
Viewing the priority 1 log 64

W

Watthour/pulse output
setting 51
Wiring
2-1/2 element metering system type 42 (calculated) 22
2-1/2 element metering system type 43 23
3-phase, 3-wire delta 18
3-phase, 4-wire wye, 3-wire load 21
3-phase, 4-wire wye, ground 19
3-phase, 4-wire wye, ground, metered neutral 20
biasing comms link 37
circuit monitors to one set of PTs and one CPT 25
communications 28
CTs, PTs, control power 17
DC control power 24
length of comms link 34
supported systems 17
terminating comms link 36

Square D Company
295 Tech Park Dr., Suite 100
LaVergne, TN 37086 USA

Printed in USA

Order No. 3020IM9807

(Replaces 3020IM9301R10/97 dated January 1998)



SQUARE D