

AQUA LUNG®

Military & Professional Operations

Helicopter Aircrew Breathing Device (H.A.B.D.)



User's Manual

Rev 04/11

COPYRIGHT NOTICE

This owner's manual is copyrighted, all rights reserved. It may not, in whole or in part, be copied, photocopied, reproduced, translated, or reduced to any electronic medium or machine readable form without prior consent in writing from Aqua Lung America, Inc.

©2011 Aqua Lung International
H.A.B.D. Owner's Manual
P/N 102897 - Rev. 04/11

TRADEMARK NOTICE

Aqua Lung®, M.A.S.™, Conshelf™, Micra™ are registered trademarks of Aqua Lung America, Inc.

Warnings, Cautions and Notes

Pay special attention to information provided in warnings, cautions, and notes, that is accompanied by these symbols:



A **WARNING** indicates a procedure or situation that may result in serious injury or death to the user.



A **CAUTION** indicates any situation or technique that will result in potential damage to the product.



A **NOTE** is used to emphasize important points, tips, and reminders.



Contents

General Precautions & Warnings.....	4
Preparation and Setup	6
Filling Procedures - General.....	6
Filling the H.A.B.D. From a SCUBA Cylinder	8
Pre-Issue Inspection.....	10
Filling the H.A.B.D. From a Compressor	12
Pre-Issue Inspection.....	13
Pre-Flight Inspection.....	15
Post-Flight Inspection.....	16
Care & Maintenance	17
Inspection & Service	19
Technical Specifications.....	20
First-Stage Exploded Parts Schematic.....	21
Second-Stage (left) Exploded Parts Schematic.....	22
Second-Stage (right) Exploded Parts Schematic... 	23
Notes.....	24

General Precautions and Warnings



The H.A.B.D. is intended for use only as an emergency device to assist aircrew members or passengers in making an emergency egress from a submerged aircraft. Due to its limited air volume, it is not intended for use while scuba diving or egressing from depths greater than 45 ft / 13.7 m.



Before using the H.A.B.D., it is important to receive in-water survival training which simulates an emergency egress situation. You must also learn basic principals and techniques for breathing compressed air underwater. Use of the H.A.B.D. without proper training is dangerous and can result in serious injury or death.



Visual inspection and factory prescribed service for the H.A.B.D. must be performed annually by a factory trained and qualified service technician. Repair, service and visual inspection must not be attempted by untrained or unqualified personnel.



DO NOT attempt to overfill the H.A.B.D beyond 3,000 PSI / 206 BAR at 70°F / 21°C. Doing so may seriously weaken the cylinder and cause it to rupture, resulting in serious injury or death.



DO NOT fill or use the H.A.B.D. if it has been exposed to extreme heat exceeding 250°F / 121°C or open flame. Instead, discharge the cylinder completely and return it to a qualified technician for inspection and possible hydrostatic testing.



The H.A.B.D. is designated compatible for use only with normal, atmospheric, compressed air (21% oxygen and 79% nitrogen by volume). **DO NOT** attempt to fill with other gases, including pure oxygen or air which has been enriched with oxygen exceeding 21% in content. Failure to observe this warning may result in serious injury or death due to fire and explosion, the serious deterioration and failure of the equipment.



DO NOT apply any type of petroleum-based lubricant, such as household oil or motor oil to any part of the H.A.B.D. The H.A.B.D. does not require any lubrication under normal circumstances, except that which is performed during annual inspection and service by a factory trained service technician.



DO NOT apply any type of aerosol spray to the H.A.B.D. Doing so may cause permanent damage to certain plastic components, including the second-stage housing.



During training exercises, it is important to ensure that the H.A.B.D. is always pressurized whenever it is submerged in order to prevent the entrance of water into the system. Whenever the system has been completely emptied of air underwater, it is important to return the H.A.B.D. as soon as possible to a qualified technician for visual inspection and any necessary service before attempting to refill it.



It is important to fill the H.A.B.D. only with dry, filtered air with a water vapor content that does not exceed -65°F / -54°C dewpoint. Excess water vapor in the air can cause ice to form inside the H.A.B.D., and interfere with the operation of the system at colder temperatures.

Component Identification



SCUBA fill adapter

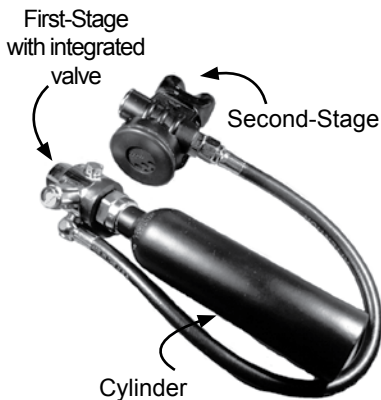

Left-handed model.

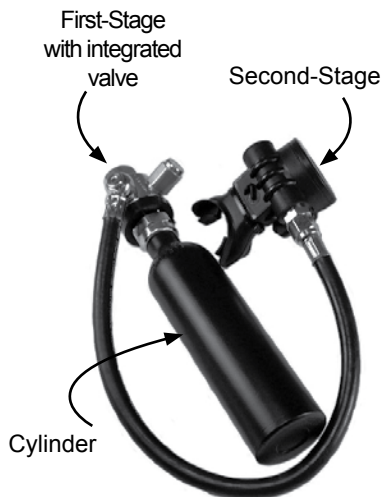

Right-handed model.

Preparation and Setup

The purpose of this manual is to familiarize you with the correct setup, filling, inspection and maintenance of the H.A.B.D. (Helicopter Aircrew Breathing Device).

The H.A.B.D. (P/N 102800) is packaged fully assembled and ready to use after it has been filled with air. Before using it, however, it is very important to carefully read and understand the procedures outlined in this manual for filling the unit and performing a pre-flight inspection.

Filling Procedures - General



NOTE: The average duration of air supply listed on page 20 of this manual is based on a completely full H.A.B.D. cylinder, filled to 3,000 PSI/ 206 BAR with a volume of 1.5 cubic ft / 42.5 liters of air. It is strongly recommended that the H.A.B.D. be filled to 3,000 PSI / 206 BAR (cold fill), in order to provide maximum breath volume.

1. Before attempting to fill the H.A.B.D., ensure that the fill adapter and first-stage are completely dry - especially in the area surrounding the high pressure port.
2. Examine the cylinder markings to verify that it is rated for a fill pressure of 3,000 PSI/ 206 BAR (See Fig. 1).



WARNING: DO NOT attempt to fill the H.A.B.D if the cylinder markings indicate that it was assembled with a non-standard cylinder rated for a different fill pressure than 3,000 PSI / 206 BAR. Doing so may result in rupture or explosion in the event of fire or overfilling. Instead, immediately return the unit to a qualified technician and do not use under any circumstances.

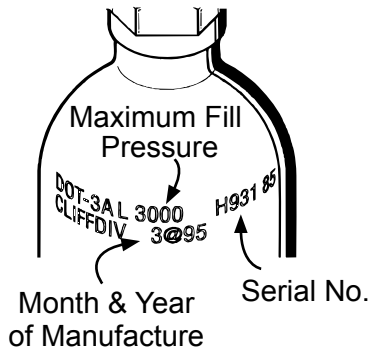

Figure 1

3. Examine the position of the "ON/OFF" indicator ring in relation to the indicator pin to determine whether the valve is open or shut. If necessary, turn the first-stage clockwise while holding the cylinder secure only until it stops and the indicator pin is positioned inside the aperture marked "OFF." (See Fig. 2).



CAUTION: When turning the H.A.B.D. "ON /OFF", over rotating can cause damage to the indicator pin.



Figure 2 - "OFF" position

4. Depress the second-stage purge button to ensure that the system is completely depressurized.
5. Apply an 11/16" open-end wrench to the pressure gauge assembly, located between the HP port which contains the safety disc assembly and the low pressure port which contains the LP hose swivel (See Fig. 3). Turn the pressure gauge assembly counter-clockwise to loosen and remove from the first-stage.



Figure 3 - Pressure gauge

6. Closely inspect the port opening to ensure that no debris, residue, or moisture is found to be present.



CAUTION: If moisture is found to be present inside the port opening, indicating that water may have entered the H.A.B.D. first-stage and cylinder, **DO NOT** fill or attempt to use the H.A.B.D. until it has received complete inspection and any required service by a qualified technician.



WARNING: Do not attempt to loosen or remove the first-stage hose fitting or safety burst plug under any circumstances. Doing so could result in a dangerous malfunction of the H.A.B.D., which could result in serious injury or death.

Filling the H.A.B.D. from a SCUBA Cylinder



NOTE: Most H.A.B.D. systems do not include a SCUBA fill adapter. This adapter (PN 108325) may be purchased separately (Refer to page 5 for component identification).

1. Using a calibrated pressure gauge, check the supply cylinder to ensure that it contains at least 2,800 PSI/ 193 BAR and less than 3,100 PSI/ 214 BAR. It is very important to ensure that the H.A.B.D. is filled to its total capacity, but not overfilled.
2. Remove the protector cap from the threaded nozzle of the fill adapter. Inspect the nozzle to ensure the O-ring is present and seated evenly at the base of the threads.



NOTE: The pressure gauge assembly may be placed inside the cap to prevent loss or damage while filling the H.A.B.D.

3. Mate the threaded nozzle of the fill adapter into the open HP port, and turn clockwise by hand until snug. **DO NOT** apply a wrench or otherwise overtighten the fill adapter into the first-stage.
4. Loosen the fill adapter yoke screw as needed so that the dust cap can be removed from the inlet fitting and the yoke can be placed over the valve of the supply cylinder.
5. While supporting the H.A.B.D. with one hand, place the yoke of the fill adapter over the cylinder valve to align the inlet fitting flush against the valve O-ring. Tighten the fill adapter yoke screw clockwise into the small dimple on the backside of the cylinder valve only until finger snug. (See Fig. 4).



Figure 4 - Filling the H.A.B.D.



WARNING: DO NOT attempt to fill the H.A.B.D. from a supply cylinder which contains more than 3,100 PSI / 214 BAR. Doing so may weaken and damage the safety burst plug assembly and / or H.A.B.D. cylinder.

6. While holding the first-stage and fill adapter secure, turn the H.A.B.D. cylinder counter-clockwise until a single click is felt and the ON-OFF indicator pin can be sighted through the small aperture marked "ON." (See Fig. 6).
7. Support the H.A.B.D. cylinder with one hand, and slowly turn the supply cylinder valve handwheel counter-clockwise to open and begin filling.
8. When at least one minute has elapsed and air can no longer be heard flowing from the supply cylinder into the H.A.B.D., turn the supply cylinder valve completely open.



NOTE: Always fill the H.A.B.D. as slowly as possible by turning the handwheel of the supply valve slowly to control the rate of fill. Rapid filling will generate heat and will result in an incomplete fill after the cylinder cools. If the cylinder is warm to the touch afterward, the fill rate was too rapid.

Pre-Issue Inspection

1. To conserve the limited air supply of the H.A.B.D., it is strongly recommended that you perform a pre-issue inspection of the second-stage purge while it is connected to the supply cylinder as follows:
 - a. Depress the purge button to ensure that sufficient airflow is provided to clear the second-stage of water.
 - b. Immediately after releasing the purge button, listen closely to ensure that the second-stage does not continue to flow any air.
2. While holding the first-stage and fill adapter secure, turn the H.A.B.D. cylinder clockwise until it stops and the indicator pin is positioned inside the aperture marked "OFF." Turn the handwheel of the supply cylinder valve clockwise until shut.
3. Hold the second-stage purge button depressed until airflow can no longer be heard from the second-stage and the LP hose between the first and Second-Stages is completely depressurized.
4. While supporting the H.A.B.D. cylinder with one hand, turn the yoke screw of the fill adapter counter-clockwise to loosen until the complete system can be lifted off and removed from the supply cylinder valve.
5. While holding the H.A.B.D. secure, turn the fill adapter counter-clockwise at the fitting to loosen and remove from the first-stage. Replace the dust cap over the inlet fitting and tighten the yoke screw until finger snug.

6. Remove the pressure gauge assembly from the protector cap which is connected to the fill adapter. Place the protector cap securely over the threaded nozzle of the fill adapter and set aside. Examine the pressure gauge assembly to ensure that the O-ring appears to be clean and dry, without any signs of decay or damage and is seated evenly at the base of the threads. If the O-ring appears to be in worn or damaged condition, it is important to obtain a new O-ring from a qualified technician before attempting to use the H.A.B.D.
7. Examine the opposite side of the pressure gauge assembly to ensure that it is completely clean and free of any debris or signs of damage which may interfere with the movement of the indicator pin.
8. Mate the threaded end of the pressure gauge assembly into the open HP port and turn clockwise by hand until finger snug. Apply an 11/16" open end wrench and tighten the pressure gauge assembly until snug (approximately 20 in-lb / 2.26 Nm). DO NOT overtighten.
9. While holding the first-stage secure, turn the H.A.B.D. cylinder counter-clockwise until it stops and the indicator pin is positioned inside the aperture marked "ON."
10. Immerse the H.A.B.D. in water to check for any signs of free-flow from the second-stage or leakage from the hose, pressure gauge, safety disc assembly, first-stage or cylinder neck. If leakage is found, do not attempt to use the H.A.B.D. until it has received service from a qualified technician.
11. While holding the first-stage secure, turn the H.A.B.D. cylinder clockwise until it stops and the indicator pin is positioned inside the aperture marked "OFF." Briefly depress the purge button to depressurize the hose and ensure that sufficient airflow is provided to clear the second-stage of water.

Filling the H.A.B.D. with Compressor Fill Adapter



NOTE: The Compressor Fill Adapter (PN 100656) is not included with the H.A.B.D. and must be purchased separately.



CAUTION: Do not attempt to fill the H.A.B.D. directly from a compressed air filling station unless you have received the necessary training and authorization to do so. If done incorrectly, this procedure poses certain hazards which may cause severe injury or death.

1. Inspect the fill adapter to ensure that the O-ring is present and seated evenly inside its groove, the male fitting is clean and free of any damage to its threads.
2. Mate the male fitting of the fill adapter into the high pressure fill port of the first-stage and turn clockwise only by hand until lightly snug. **DO NOT** apply a wrench or otherwise overtighten the fill adapter.
3. Loosen the yoke screw of the compressor fill yoke as needed so that the yoke can be placed over the block of the fill adapter.
4. While supporting the H.A.B.D. with one hand, place the yoke of the compressor fill yoke over the block of the fill adapter to align the inlet fitting flush against the valve O-ring. Tighten the fill yoke screw clockwise into the small dimple on the backside of the fill adapter block only until finger snug (See Fig. 5).



Figure 5 - Fill Yoke Connection



WARNING: **DO NOT** attempt to fill the H.A.B.D. from an air supply which exceeds 3,000 PSI / 206 BAR. Doing so may weaken and damage the safety burst plug assembly and / or H.A.B.D. cylinder.

5. While holding the first-stage and fill adapter secure, turn the cylinder counter-clockwise until a single click is felt and the ON-OFF indicator pin can be sighted through the small aperture marked "ON" (See Fig. 6).

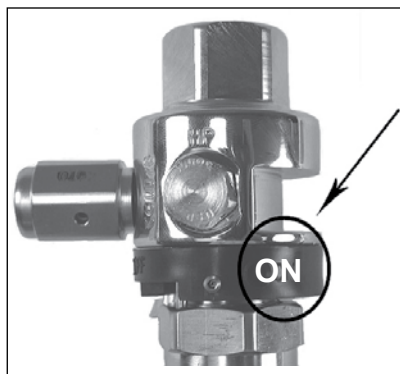

Figure 6 - "On"
Position

6. Ensure that the H.A.B.D. is supported and turn the compressor valve **very slowly** until it is slightly open to fill the cylinder with approximately 500 PSI / 34.5 BAR. Turn the fill valve shut and wait 45-60 seconds before proceeding to fill the cylinder any further. Repeat this procedure to fill the cylinder very slowly in increments of 500 PSI / 34.5 BAR or less, until it is filled to exactly 3,000 PSI / 206 BAR.



NOTE: Always fill the H.A.B.D. as slowly as possible. Rapid filling will generate heat and may result in an incomplete fill after the cylinder cools. If the cylinder is warm to the touch afterward, the fill rate was too rapid.

Pre-Issue Inspection

1. To conserve the limited air supply of the H.A.B.D., it is strongly recommended that you perform the following pre-issue inspection of the second-stage purge while the H.A.B.D. is connected to the compressor fill yoke and pressurized via the compressor fill adapter:
 - a. Briefly depress the purge button to ensure that sufficient airflow is provided to clear the second-stage.
 - b. Immediately after releasing the purge button, listen closely to ensure that the second-stage does not continue to flow any air.

2. Turn the compressor fill valve completely closed. While holding the first-stage and compressor fill adapter secure, turn the H.A.B.D. cylinder clockwise until it stops and the indicator pin is positioned inside the "OFF" aperture.



CAUTION: DO NOT turn the first-stage any farther than is necessary to shut the valve. Doing so will cause undue stress and possible damage to the valve and indicator pin.

3. Hold the second-stage purge button depressed until airflow can no longer be heard from the second-stage and the LP hose is depressurized.
4. While holding the H.A.B.D. cylinder supported, turn the yoke screw of the compressor fill yoke counter-clockwise to loosen until the compressor fill valve can be removed from the block of the fill valve adapter. Return the compressor fill yoke to its storage location.
5. Examine the pressure gauge assembly to ensure that the O-ring appears to be clean and dry, without any signs of decay or damage and is seated evenly at the base of the threads. If the O-ring appears to be in worn or damaged condition, it is important to obtain a new O-ring from a qualified technician before attempting to use the H.A.B.D.
6. Examine the opposite side of the pressure gauge assembly to ensure that it is completely clean and free of any debris or signs of damage which may prevent it from reading clearly and accurately.
7. Mate the threaded end of the pressure gauge assembly into the open HP port and turn clockwise by hand until finger snug. Apply an 11/16" open end wrench and tighten the pressure gauge assembly until snug (approximately 20 in-lb / 2.26 Nm.) DO NOT overtighten.
8. While holding the first-stage secure, turn the H.A.B.D. cylinder counter-clockwise until it stops and the indicator pin is positioned inside the aperture marked "ON."
9. Immerse the H.A.B.D. in water to check for any signs of free-flow from the second-stage or leakage from the hose, pressure gauge, safety disc assembly, first-stage or cylinder neck. If leakage is found, do not attempt to use the H.A.B.D. until it has received service from a qualified technician.
10. While holding the first-stage secure, turn the H.A.B.D. cylinder clockwise until it stops and the indicator pin is positioned inside the aperture marked "OFF." Briefly depress the purge button to depressurize the hose and ensure that sufficient airflow is provided to clear the second-stage of water.

Pre-Flight Inspection

Before each use, the unit must be given a thorough visual inspection and functional test. NEVER use an H.A.B.D. which shows signs of damage, leakage or substandard performance until it has received inspection and service from a qualified technician.



WARNING: Strict compliance of pre-flight and post flight inspections shall be adhered to by all aircrew members utilizing the H.A.B.D. Any signs of discrepancies shall be reported immediately to maintenance personnel.

1. Carefully inspect the low pressure hose to ensure it is securely connected into its respective port on the first-stage and onto the second-stage. Inspect the length of the hose to ensure that it is not blistered, cut or otherwise damaged. If a hose protector is present, slide it back to expose the hose fitting and inspect for any signs of corrosion.
2. Visually inspect the entire system for any external damage, such as dents, gouges or severe external corrosion.
3. While the H.A.B.D. valve is completely shut and the system is depressurized, inspect the pressure gauge assembly to ensure that it is securely fastened to the first-stage and cannot be loosened by hand. Closely examine the pressure gauge to ensure that the needle rests at 0 psi.



CAUTION: If the pressure gauge does not read 0 psi when the valve is shut and the system is depressurized, DO NOT attempt to use the system until it has received inspection and service from a qualified technician.

4. While holding the first-stage secure, slowly turn the H.A.B.D. cylinder counter-clockwise until a single click is felt and the indicator pin can be sighted through the "ON" aperture.



CAUTION: DO NOT attempt to open the H.A.B.D. valve without first checking to ensure that the LP hose and pressure gauge assembly are securely fastened to the first-stage.

5. Closely examine the pressure gauge to determine whether the needle is within the green zone, indicating that the H.A.B.D. cylinder is full (See Fig. 7). If the pressure gauge does not indicate that the cylinder is completely full, repeat the filling procedure using a supply cylinder that is filled to 3,000 PSI/ 206 BAR.



Figure 7 - "Full" Indication



CAUTION: Do not press the purge button (if equipped) when the H.A.B.D. is on. Purging of the H.A.B.D. may deplete the pressure below the "GREEN ZONE" and it will have to be topped off by maintenance personnel before use.

Provided that these pre-flight inspection requirements have all been met, the H.A.B.D. is now ready to use.

Post Flight Inspection

1. Upon completion of the flight, turn the H.A.B.D. off by holding the first-stage secure and turn the cylinder clockwise until it stops and the indicator pin is positioned inside the large aperture marked "OFF". Depress the purge button to relieve the pressure in the hose and the second-stage. Check the H.A.B.D. for signs of damage, contamination and / or missing parts. Report all discrepancies to maintenance personnel.

Care and Maintenance

It is important to provide the proper preventative maintenance in order to ensure the best possible performance and reliability of the H.A.B.D. The following maintenance procedures should be performed routinely after each use of the equipment.

1. After each in-water training session, the H.A.B.D. must be cleaned, inspected, prepared for the next use or for storage.
2. As soon as possible after training, the H.A.B.D. should be soaked thoroughly for at least one hour in warm (not over 120°F/ 49°C) tap water to loosen and dissolve salt and mineral deposits. Before soaking, turn the valve to the "ON" position to pressurize the system. This will best prevent the entrance of moisture into the system through the second-stage.



CAUTION: If the H.A.B.D. cylinder does not contain air, it is important to ensure that the valve is completely turned to the "OFF" position, and the second-stage purge button is not depressed while the system is submerged or wet. Moisture may otherwise be allowed to enter the valves and the cylinder, which will require that the system be returned to a qualified technician for inspection and service.

3. After the system has been properly soaked, it is important to rinse it vigorously by flushing the mainspring cavity of the first-stage, the second-stage mouthpiece and the openings in the second-stage front cover with a pressurized stream of water. This will remove the salt and mineral deposits that were loosened during soaking.
4. When it has been properly soaked and rinsed, wipe the system as dry as possible with a clean towel and gently shake the second-stage to dislodge any water inside it.
5. Check to ensure that the H.A.B.D. valve is turned to the "OFF" position and depress the purge button of the second-stage to ensure that the system is completely depressurized before storing or transporting.

6. Due to the possibility of fire and exposure to extreme heat, the H.A.B.D. must be stored either completely full or completely empty. If the system is exposed to fire while partially filled, the cylinder wall may rupture before the internal pressure becomes great enough to burst the safety relief disc. For this reason, Aqua Lung recommends that the cylinder be completely emptied and the valves kept shut to prevent the entrance of moisture before storing the system for an indefinite period.



WARNING: DO NOT store the H.A.B.D. partially filled. Doing so may prevent the safety relief assembly from functioning properly in the event of fire or exposure to extreme heat. This may cause the cylinder to rupture or explode, possibly resulting in severe injury or death.

7. Store the H.A.B.D. completely dry, in a clean equipment box or sealed inside a plastic bag. When possible, avoid storing it where it may be exposed to extreme heat or an electric motor, which produces ozone. Prolonged exposure to extreme heat, ozone, chlorine and ultraviolet rays can cause premature degradation of rubber parts and components and must be prevented.
8. When transporting the H.A.B.D., take the necessary precautions to ensure that it is surrounded by a protective cushion to prevent undue shock or impact.
9. Do not use any type of solvent or petroleum based substances to clean or lubricate any part of the regulator. Do not expose the regulator to aerosol spray, as some aerosol propellants attack or degrade rubber and plastic.

Inspection & Service

1. It cannot be assumed that the H.A.B.D. is in good working order on the basis that it has received little use since it was last serviced. Remember that prolonged or improper storage can still result in internal corrosion and/or deterioration of O-ring seals and valve springs.
2. It is imperative that you obtain factory prescribed service for your H.A.B.D. at least once a year from a qualified technician, including a visual inspection of the cylinder, and complete overhaul of the first-and second-stage regulators. Your H.A.B.D. may require this service more frequently, depending on the amount of use it receives and the environmental conditions it is used in.
3. If the H.A.B.D. is used for training purposes in saltwater, chlorinated or silted fresh water, it will require complete overhaul and factory prescribed service every three to six months or whenever it is suspected that moisture has entered the system. Use in chlorinated swimming pool water will accelerate the deterioration of most rubber components and require more frequent service than in other typical conditions.
4. DO NOT attempt to perform any disassembly or service of your H.A.B.D. Doing so may cause the system to dangerously malfunction. All service must be performed by a qualified technician.



WARNING: Do not attempt to loosen or remove the first-stage hose fitting or safety burst plug under any circumstances. Doing so could result in a dangerous malfunction of the H.A.B.D., which could result in serious injury or death.

OBTAIN FACTORY PRESCRIBED SERVICE FOR YOUR H.A.B.D. ANNUALLY. YOUR PERSONAL SAFETY AND THE MECHANICAL INTEGRITY OF YOUR H.A.B.D. DEPENDS ON IT.

Technical Specifications

Cylinder Volume	1.5 cf / 42.5 liters
Cylinder Material	Aluminum
Cylinder Length with Regulator	10.5 in / 26.67 cm
Rated Cylinder Pressure	3,000 PSI / 206 BAR
Low Pressure Hose Length	20 in / 50.8 cm
First-Stage Hose Connection	360 degree swivel
Regulator First-Stage	Modified Conshelf™ (Balanced Diaphragm)
Regulator Second-Stage	Modified Micra™
Pressure Gauge	Analog, Integrated with First-Stage
Over Pressure Relief	Safety Burst Disc Assembly First-Stage Mounted
System Weight	Approximately 3 lbs / 1.36 kg
Buoyancy Full	Approximately -2.0 lbs / -.9 kg
Duration of Air Supply	*Approximately 12-15 breaths at 33 ft / 10 m.
	* Based on an average breath volume of 1.5 Liters, with a starting supply pressure of 3,000 PSI / 206 BAR.

H.A.B.D. First-Stage with Cylinder Assembly

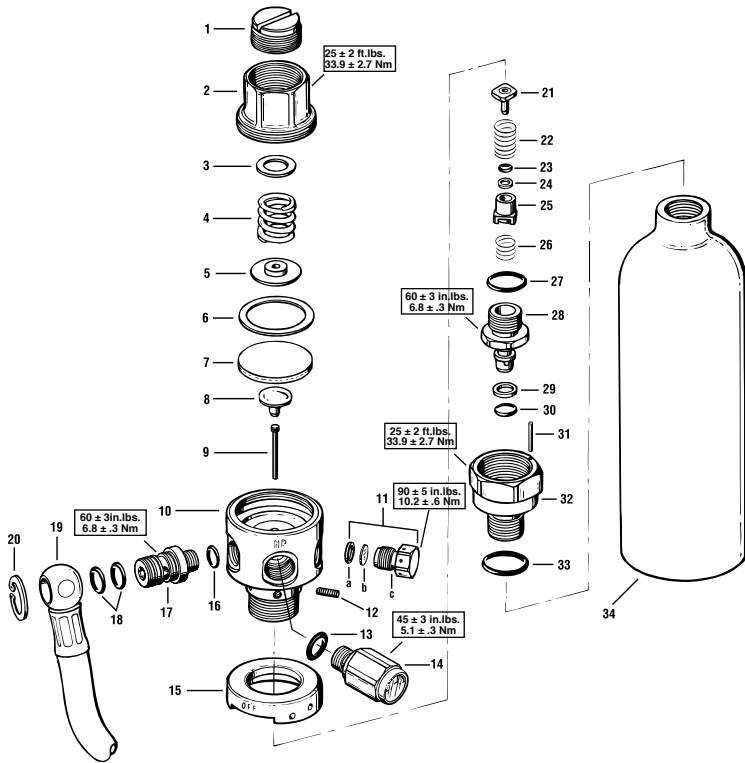

Key # Part # Description

----	102871	1st Stage Spare H.A.B.D. /SRU-40 B/P
----	211962	Overhaul Service Kit (10PK)
----	102881	Overhaul Service Kit H.A.B.D. /SRU-40 B/P
1----	106023	Adjustment Screw
2----	100627	Spring Retainer
3----	845097	Washer, Nylon, Main Spring
4----	105327	Main Spring
5----	101728	Spring Pad
6----	103425	Thrust Washer (A)
7----		Diaphragm (B)
8----	101727	Pin Support
9----	102823	Pin
10----	100601	Body, First-Stage
11----	050241	Safety Disc Assy, 3000 psi
12----	100623	Screw, Set
13----	820319P	O-ring (10 pk)
14----	102873	Pressure Gauge Assy
15----	100614	Ring Indicator
16----	820311P	O-ring (10 pk)

Key # Part # Description

17----	102812	LP Port Swivel (w/ Hex Slot)
18----	820312P	O-ring (10 pk)
19----	102835	Hose Assy 20"
20----	860065	Hose Retaining Ring
21----	105321	HP Seat, Black Rubber
22----	101504	Spring HP Seat
23----	820306	O-ring
24----	828005	Back-up Ring
25----	105324	HP Spring Block
26----	104613	Spring
27----	820314	O-ring
28----	102822	Valve Assy
29----	828510	Backup Ring
30----	820310P	O-ring (10 pk)
31----	100609	Indicator Pin
32----	100605	Cylinder Adapter
33----	820316P	O-ring (10 pk)
34----	079105	1.5 cf Cylinder, Black
N/S----	100699	Retrofit Kit, Extreme Weather SRU-40 B/P

Part numbers in **BOLD ITALICS** indicate standard overhaul replacement parts.

H.A.B.D. Second-Stage (Left Hand Version)

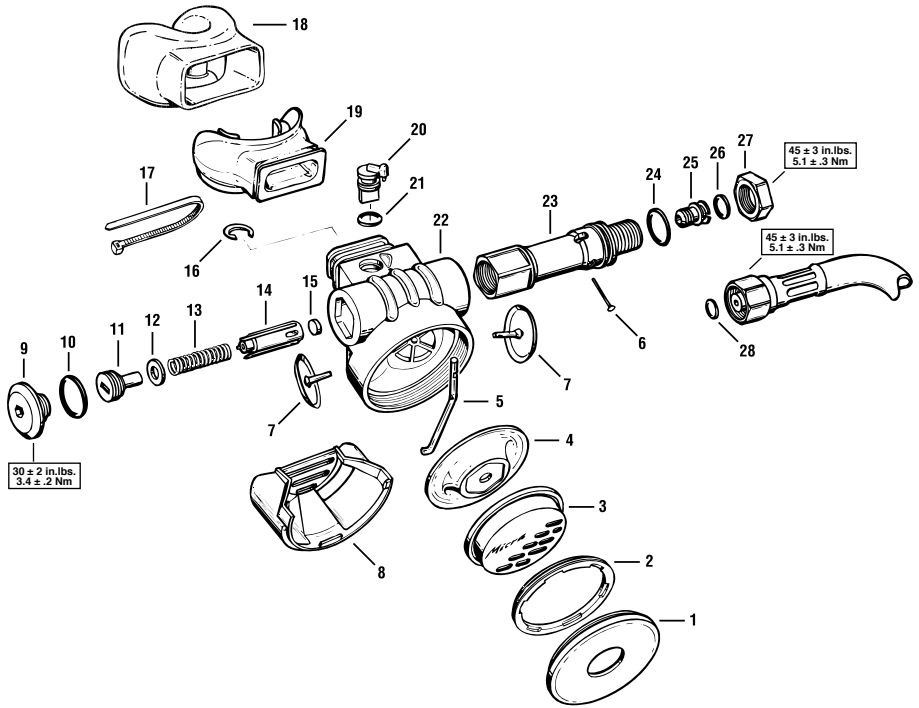

Key #	Part #	Description	Key #	Part #	Description
----	102872	2nd Stage Spare H.A.B.D. SRU-40 B/P	14 ----	100127	Poppet
----	102882	Overhaul Service Kit, 2nd Stage H.A.B.D. SRU-40 B/P	15 ----	106738	Disc Seat
1 ----	100652	Cover Hard Purge Guard	16 ----	860137	Retaining Ring
2 ----	100119	Ring, Retainer	17 ----	104913	Clamp, Strap, Black
3 ----	100104	Purge Cover	18 ----	100653	Mouthpiece Cover
4 ----	100181	Demand Diaphragm	19 ----	105831	Mouthpiece
5 ----	100257	Lever, Coated, Left	20 ----	100108	Vane Adjusting, (Anti-Venturi)
6 ----	100132	Pin	21 ----	820310P	O-ring (10 pk)
7 ----	100122	Valve Exhaust, 1.0"	22 ----	102844	Box Bottom (6 spokes)
8 ----	100109	Exhaust Cover	23 ----	100245	Valve Body, Left
9 ----	100262	Cap Plug, Left, Chrome	24 ----	820015P	O-ring (10 pk)
10 ----	820017P	O-ring (10 pk)	25 ----	100128	Crown Orifice
11 ----	100223	Adjustment Screw (black)	26 ----	820310P	O-ring (10 pk)
12 ----	100173	Washer, Red	27 ----	100236	Hex Nut, 13/16", Left
13 ----	100134	Spring	28 ----	820310P	O-ring (10 pk)
			N/S----	100699	Retrofit Kit, Extreme Weather, SRU-40 B/P

Part numbers in **BOLD ITALICS** indicate standard overhaul replacement parts.

H.A.B.D. Second-Stage (Right Hand Version)

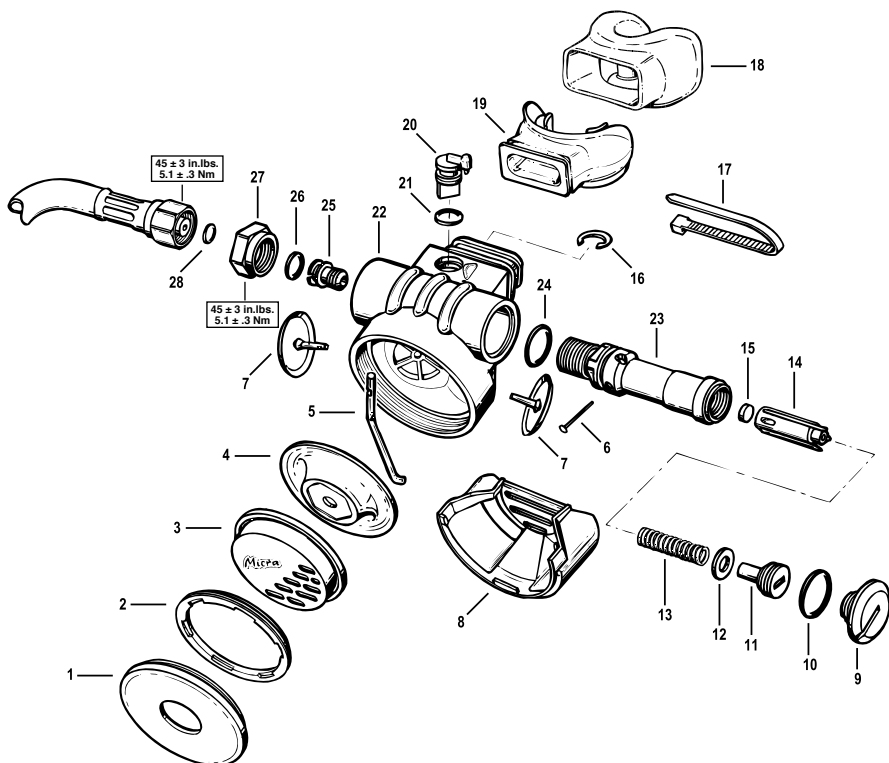

Key # Part # Description

----	211961	Overhaul Service Kit 2nd stage CF-MAS (RH) (10 PK)
1 ----	100652	Cover Hard Purge Guard
2 ----	100119	Ring, Retainer
3 ----	100104	Purge Cover
4 ----	100181	Demand Diaphragm
5 ----	100157	Lever Teflon® Coated
6 ----	100132	Pin
7 ----	100122	Exhaust Valve 1.0"
8 ----	100109	Exhaust Cover
9 ----	100162	Cap Plug, Black
10 ----	820016P	O-ring (10 pk)
11 ----	100123	Adjustment Screw (white)
12 ----	100173	Washer, Red
13 ----	100134	Spring

Key # Part # Description

14 ----	100127	Poppet, Blue
15 ----	106738	Disc Seat
16 ----	860137	Retaining Ring
17 ----	104913	Clamp, Strap, Black
18 ----	100653	Mouthpiece Cover
19 ----	105831	Mouthpiece, Black
20 ----	100108	Anti-Venturi Vane
21 ----	820310P	O-ring (10 pk)
22 ----	102844	Box Bottom (6 spokes)
23 ----	100145	Valve Body
24 ----	820314	O-ring
25 ----	100128	Crown Orifice
26 ----	820310P	O-ring (10 pk)
27 ----	100136	Hex Nut, 3/4"
28 ----	820310P	O-ring (10 pk)
N/S----	100699	Retrofit Kit, Extreme Weather SRU-40 B/P

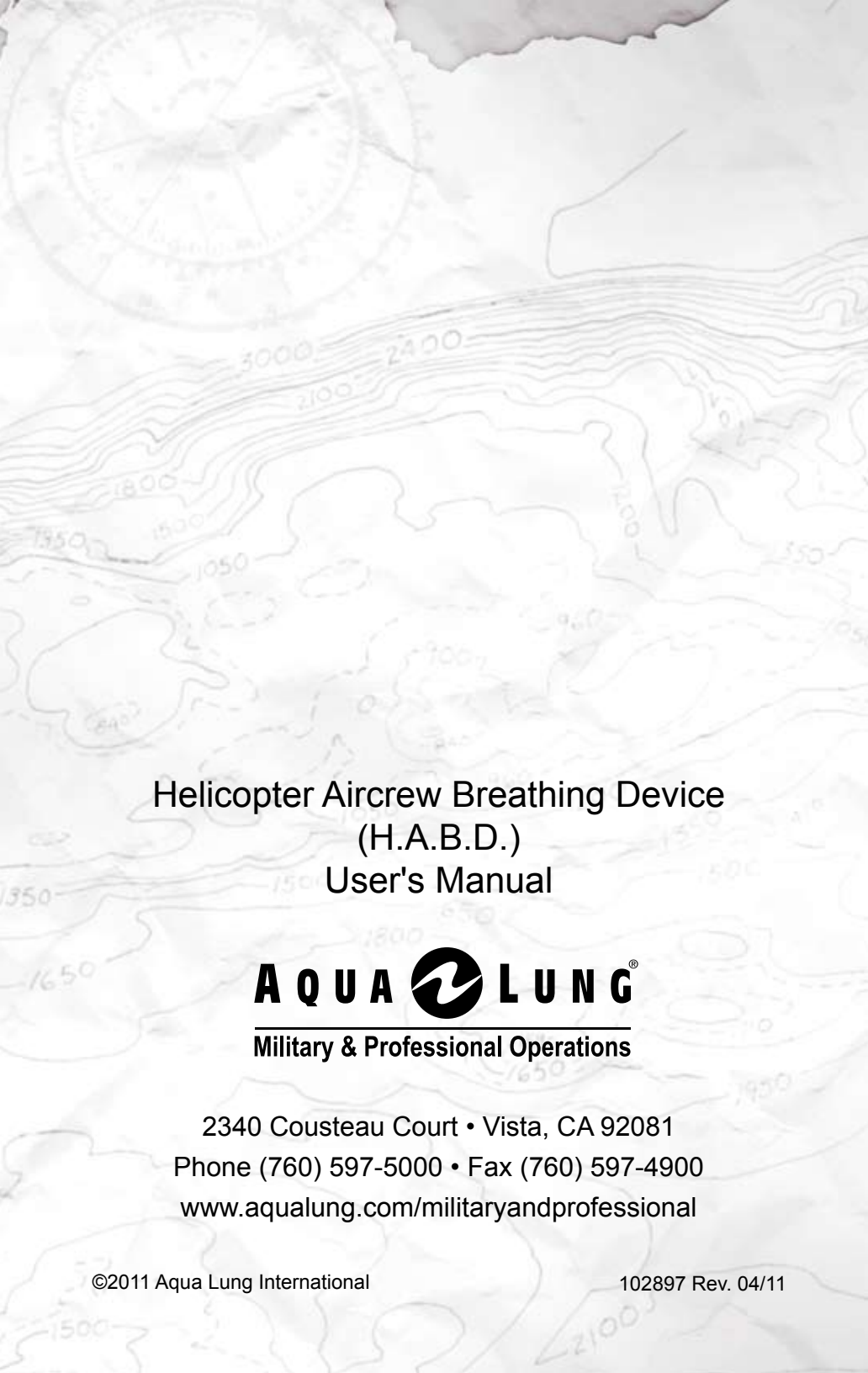

Helicopter Aircrew Breathing Device
(H.A.B.D.)
User's Manual

AQUA LUNG[®]
Military & Professional Operations

2340 Cousteau Court • Vista, CA 92081
Phone (760) 597-5000 • Fax (760) 597-4900
www.aqualung.com/militaryandprofessional