

*Sixteen Channel
Controller*



THE INFORMATION CONTAINED IN THIS MANUAL IS ACCURATE TO OUR KNOWLEDGE.

As a result of continuous research and development, the specifications of this product may be modified at any time without prior notice.

IMPORTANT INFORMATION

The modification of the material and the use of parts of an unspecified origin shall entail the cancellation of any form of warranty.

The use of the unit has been projected for applications specified in the technical characteristics. Exceeding the values cannot in any case be authorized.

LIABILITY

Neither Oldham nor any other associated company can be held liable for any damages, including, without limitations, damages for the loss or interruption of manufacture, loss of information, defect of the WX4 unit, injuries, loss of time, financial, or material loss, or any direct or indirect consequence of loss occurring in the context of the use or impossibility of use of the product, even in the event that Oldham has been informed of such damage.

SAFETY INSTRUCTIONS

Labels intended to remind you of the principal precautions of use have been placed on the unit in the form of pictograms. These labels are considered an integral part of the unit. If a label falls off or becomes illegible, see to it that it is replaced.



Warning: Read & understand contents of this manual prior to operation. Failure to do so could result in serious injury or death.

Table of Contents

SECTION - 1	7
Important Safety Issues	7
1.0 General Description	8
1.1 Data Display Screens	9
1.1.1 Trend Screen	9
1.1.2 Bar Graphs Screen	9
1.1.3 Combination Screen	9
1.2 Specifications	10
1.2.1 DC Power Supply Requirements	10
1.2.2 Relays	10
1.2.3 Ambient Temperature Range	10
1.2.4 Humidity Range	10
1.2.5 Altitude	10
1.2.6 Housings	10
1.2.7 Approvals	11
SECTION - 2	13
2.0 Basic Operation	13
2.1 Setup Menu Configuration	14
2.1.1 Changing Menu Variables Using the Keypad	14
2.2 Channel Configuration Menus	15
2.2.1 Channel Setup Entry Menu	16
2.2.2 Alarm 1 / Alarm 2 / Horn Relay Setup Menu	16
2.2.3 Alarm 3 / Fault Alarm Menu	17
2.2.4 Data From? Menu to Set Input Source	17
2.2.5 Linearization Menu	20
2.2.6 Configure Menu	20
2.2.7 Cal Mode	22
2.3 System Configuration Menus	24
2.3.1 Common Alarm Relays 1 & 2	25
2.3.2 10-0195 Discrete Relay “Failsafe” Mode	26
2.3.3 Common Horn Relay & Local Piezo	26
2.3.4 Comm Port Menus	27
2.3.5 Eight / Sixteen Channel Modes	28
2.3.6 Sensor Information	29
2.4 Authorization Mode	29
2.5 LCD Contrast Adjustment	30
SECTION - 3	31
3.0 Main I/O Interface PCB #10-0142	31
3.1 Input / Output Optional PCB’s	32
3.1.1 Optional Analog Input PCB #10-0158	32
3.1.2 Optional Discrete Relay PCB #10-0195	34
3.1.3 Optional *Bridge Sensor Input Board #10-0191	36

3.1.4	Catalytic Bead Sensor Initial Setup	37
3.1.5	Optional RTD / 4-20mA Analog Input Board #10-0170	38
3.1.6	Optional 4-20mA Analog Output Board #10-0167	41
3.1.7	Optional Clock / Printer Interface Board #10-0229	42
3.1.8	Optional 24 VDC 150 Watt Power Supply	44
SECTION - 4		45
4.0	System Diagnostics	45
SECTION - 5		49
5.0	ModBus RS-485 Ports	49
5.1	ModBus Slave Register Locations	49
SECTION - 6		57
6.0	Panel / Rack Mount Enclosure	57
6.1	NEMA 4X Wall Mount Fiberglass Enclosure	58
6.2	NEMA 4X Wall Mount 316 Stainless Steel Enclosure	60
6.3	XP NEMA 7 Explosion-Proof Wall Mount Enclosure	61
6.4	Main I/O & Option PCB Footprint Dimensions	61
SECTION - 7		63
7.0	Adding The "Wireless" Radio Kit Option	63
7.1	Radio Setup Menu	64
7.2	Wireless Receiver Mode	65
7.2.1	Radio Status Alarms - Wireless Receiver Mode	65
7.3	Wireless ModBus Slave Mode	66
7.4	Wireless ModBus Master Mode	67
7.5	Antenna Selection	67
7.5.1	Dipole And Collinear Antennas	67
7.5.2	Yagi Antennas	68
7.5.3	Mounting Near Other Antennas	68
7.5.4	Coax Cables	68
7.6	Surge Protection & Grounding	69
7.6.1	Antenna Grounding	69
7.6.2	Connections to Other Equipment	70

SECTION - 1.

Important Safety Issues

The following terms and symbols are used in this manual to alert the operator of important instrument operating issues:



This symbol is intended to alert the user to the presence of important operating and maintenance (servicing) instructions.



This symbol is intended to alert the user to the presence of dangerous voltage within the instrument enclosure that may be sufficient magnitude to constitute a risk of electric shock.



WARNINGS:

- **Shock Hazard** - Disconnect or turn off power before servicing this instrument.
- NEMA 4X wall mount models should be fitted with a locking mechanism after installation to prevent access to high voltages by unauthorized personnel (see Figure 6.2).
- Only the combustible monitor portions of this instrument have been assessed by CSA for C22.2 No. 152 performance requirements.
- This equipment is suitable for use in Class I, Division 2, Groups A, B, C, and D or non-hazardous locations only.
- **WARNING- EXPLOSION HAZARD-** SUBSTITUTION OF COMPONENTS MAY IMPAIR SUITABILITY FOR CLASS I, DIVISION 2.
- **WARNING- EXPLOSION HAZARD-** DO NOT REPLACE FUSE UNLESS POWER HAS BEEN SWITCHED OFF OR THE AREA IS KNOWN TO BE NON-HAZARDOUS.
- **WARNING- EXPLOSION HAZARD-** DO NOT DISCONNECT EQUIPMENT UNLESS POWER HAS BEEN SWITCHED OFF OR THE AREA IS KNOWN TO BE NON-HAZARDOUS.
- Use a properly rated CERTIFIED AC power (mains) cable installed as per local or national codes
- A certified AC power (mains) disconnect or circuit breaker should be mounted near the controller and installed following applicable local and national codes. If a switch is used instead of a circuit breaker, a properly rate CERTIFIED fuse or current limiter is required to installed as per local or national codes.

Markings for positions of the switch or breaker should state (I) for on and (O) for off.

- Clean only with a damp cloth without solvents.
- Equipment not used as prescribed within this manual may impair overall safety.

1.0 General Description

The Oldham WX16 Sixteen Channel Controller is designed to display and control alarm event switching for up to sixteen sensor data points. It may also be set as an eight channel controller for applications needing fewer inputs. Alarm features such as *ON* and *OFF* delays, *Alarm Acknowledge*, and a dedicated horn relay make the WX16 well suited for many multi-point monitoring applications. Data may be input to the WX16 by optional analog inputs or the standard ModBus® RTU *master* RS-485 port. A ModBus RTU *slave* RS-485 port is also standard for sending data to PC's, PLC's, DCS's or even other WX16 Controllers. Options such as analog I/O and discrete relays for each alarm are easily added to the addressable I²C bus. Option boards have 8 channels and therefore require 2 boards for 16 channel applications.

In addition to traditional analog and serial methods of providing monitored values, the WX16 is also capable of sending and receiving wireless data as described in section 7 of this manual.

A 240 x 128 pixel graphic LCD readout displays monitored data as bar graphs, trends and engineering units. System configuration is through user friendly menus and all configuration data is retained in non-volatile memory during power interruptions. The WX16 front panel is shown below in Figure 1.0 displaying the 8 channel bar graph screen. Additional data screens are shown in Figure 2.0.

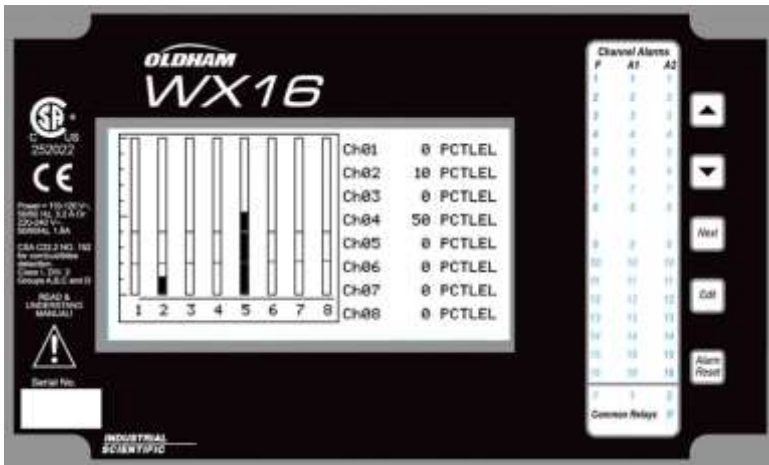

Figure 1.0

1.1 Data Display Screens

The WX16 Controller offers three distinct graphic displays for depicting the monitored data. These are Bar Graphs, 24 Hour Trend and Combination. Each is shown in Figure 2.0.

1.1.1 Trend Screen

The WX16 Trend screen shown in Figure 2.0 displays a 24-hour trend of input data for the channel selected. Horizontal tic marks are each hour and vertical tick marks are each 10% of full scale. Dashed lines indicate alarm levels. The graphic LCD is 240 pixels wide, so each pixel represents 1/10 hour, or 6 minutes worth of data. The trend is 100 pixels high, so each represents 1% of full scale in amplitude. Since each data point must be collected for 6 minutes before it may be displayed, it is likely input values will fluctuate during this interval. Therefore, MAX, MIN and AVERAGE values are stored in RAM memory for each 6-minute subinterval. To accurately portray the trend, a vertical line is drawn between MIN & MAX values for each 6-minute subinterval. The AVERAGE value pixel is then left blank, leaving a gap in the vertical line. This is demonstrated in the *noisy* area of the 24-hour trend in Figure 2.0. If the MAX & MIN values are within 2% of each other, there is no need for the vertical line, and only the AVERAGE value pixel is darkened as in the *quiet* areas.

The top portion of each trend screen indicates channel #, real time reading in engineering units, measurement name, range, and MIN, MAX & AVERAGE values for the preceding 24-hour period. The SI field on the top right indicates number of seconds remaining in the current 6-minute subinterval.

1.1.2 Bar Graphs Screen

The WX16 Bar Graphs screen shown in Figure 2.0 allows all active channels to be viewed simultaneously. Both engineering units values and bar graph values are indicated in real time. Lines across the bars indicate the alarm trip points making it easy to identify channels at or near alarm. A feature in the Systems menu tree allows new alarms to always force the LCD to the bar graphs screen. This is useful for applications requiring channels with alarms to be displayed.

1.1.3 Combination Screen

The WX16 Combination screen shown in Figure 2.0 offers a view of a single channel but displays the data as a 30-minute trend, bar graph and large engineering units. It is also useful for testing inputs for stability since MAX, MIN & AVERAGE values refresh each time this screen is selected. For example, to test stability over a one-hour period for an input, begin timing as soon as the channel is selected. One hour later, record the MAX, MIN & AVERAGE values. The difference between MAX & MIN indicates peak to peak excursions over the one-hour period and AVERAGE is the average for the hour. Longer or shorter tests may also be run. The numeric value shown below the bar graph indicates number of minutes samples have been taken. After 999 minutes the AVERAGE buffer overflows and the message *ERROR* appears in the AVERAGE field. Exiting this screen resets the buffer and clears the error message.

1.2 Specifications

1.2.1 DC Power Supply Requirements

Standard WX16 power requirements are 10-30 VDC @ 3 watts applied to terminals 9 & 11 of TB2 on the standard I/O PCB (see section 3.0). Optional features increase power consumption as described below:

- Discrete Relay PCB option; add 2 watts per PCB (assumes all 8 relays are energized).
- Analog Input PCB option; add 1/2 watt.
- 4-20mA Output PCB option; add 1 watt.
- Catalytic Bead Sensor Input option; add 12 watts max (assumes maximum sensor power consumption).
- TB2 terminals 10 & 12 of the standard I/O PCB provide a maximum of 500mA fused output power for powering of auxiliary external devices such as relays, lamps or transmitters. Power consumed from these terminals should be considered when calculating system power consumption.

1.2.1.1 150 Watt AC – 24 VDC Power Supply

* 110-120 VAC @3.2A max

* 220-240 VAC @ 1.6A max

* A slide switch on the front of the power supply selects AC input range.

The 10-0172 150 watt power supply (Figure 3.8) is for powering the WX16 and up to 16 detectors. A minimum of 5 watts per channel is available for powering of external transmitters.

1.2.2 Relays



Common relays are standard and menus provide voting logic for ALARM 1, ALARM 2, FAULT and HORN. Discrete relays are optional. All relays are rated at 5 Amp for 28 VDC and 250 ~VAC **RESISTIVE** loads.

IMPORTANT: Appropriate diode (DC loads) or MOV (AC loads) snubber devices must be installed with inductive loads to prevent RFI noise spikes. Relay wiring should be kept separate from low-level signal wiring.

1.2.3 Ambient Temperature Range

-25 to 50 degrees C

1.2.4 Humidity Range

0 to 90% R. H. Non-Condensing

1.2.5 Altitude

Recommended up to 2000 meters

1.2.6 Housings

General purpose panel mount weighing 7 lbs and including hardware for 19" rack mounting (Figure 6.1).

* NEMA 4X wall mount in fiberglass enclosure weighing 17 lbs (Figure 6.2).

- * NEMA 7 wall mount suitable for DIV 1&2 Groups B,C,D weighing 110 lbs (Figure 6.4).
- * Includes non-intrusive magnetic keypad.

1.2.6.1 Non-Intrusive Magnetic Keypad

The WX16 operator interface includes five front panel *touch* keys. A magnetic keypad option offers these five keys with adjacent magnetic keys. This option is included as a standard feature. It is useful in applications where it may be inconvenient to open the enclosure's door to access the *touch* keypad.

1.2.7 Approvals

CSA C22.2 No 1010.1 and ISA S82.02; CSA C22.2 No 152 for combustibles; UL 1604 / C22.2 No 213 (Div 2 Groups A,B,C,D); EN55011 & EN61000 (CE Mark). CSA File # = 252022 and may be seen at: CSA-International.org.

SECTION - 2.

2.0 Basic Operation

The WX16 offers 3 graphic screens for viewing monitored data and a *Setup* menu screen for operator interface to configuration menus. They are shown below in Figure 2.0. The *Bar Graphs* screen allows viewing of all active channels simultaneously. The *Trend* screen displays a 24-hour trend one channel at a time. The *Combination* screen displays a bar graph, large engineering units and a 30-minute trend one channel at a time. Input channels may be displayed in sequence with the **UP/DOWN** keys. The **NEXT** key switches between the 3 graphic data screens. When WX16 power is applied, the graphic LCD returns to the screen active when power was last removed.

Setup menus are entered by pressing **EDIT** from any data screen, and scrolling to the desired menu using the **UP/DOWN** keys. Pressing **EDIT** again enters the selected menu's tree of variables. This *Setup* mode may be exited manually by pressing **NEXT**, or automatically when no keys are pressed for 5 minutes. Alarm relays and front panel alarm LED indicators remain active during the *Setup* mode. An **AUTHORIZE** menu offers a password feature to prevent tampering with WX16 parameters.

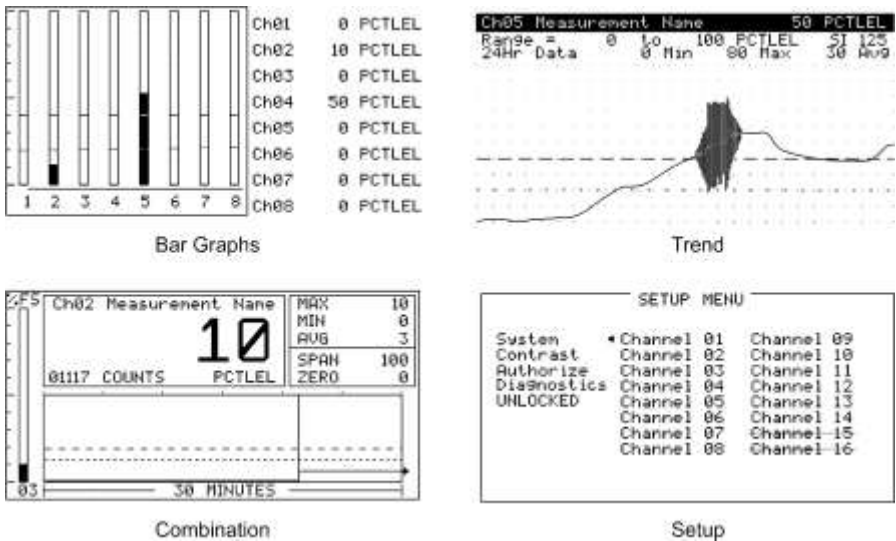

Figure 2.0

2.1 Setup Menu Configuration

Variables inside *system* and *channel* menu trees allow optimum WX16 configuration for a wide range of demanding multi-point monitoring applications. Access to menus is via the *Setup* mode by pressing **EDIT** and activating the *Setup* screen shown in Figure 2.0. Menu trees are provided for each of the 16 channels and another for system variables. Select the desired menu by scrolling with **UP/DOWN** and **EDIT** to enter the menus.

2.1.1 Changing Menu Variables Using the Keypad

Upon entering a menu, a pointer controlled by the **UP/DOWN** keys indicates the selected variable. Some are simple **YES/NO** or **ON/OFF** entries toggled by pressing the **EDIT** key. Others, such as *Measurement Name* and *Eunits* fields may have many ASCII character possibilities. Allowed ASCII characters are as follows: ABCDEFGHIJKLMNOPQRSTUVWXYZabcdefghijklmnopqrstuvwxyz blank space !"#\$%&`()*+,-./0123456789:;<=>?@. **EDIT** places a cursor over the item and **UP/DOWN** scrolls through each allowed entry. The **NEXT** key moves the cursor to the next position within a field. When the field is complete, **EDIT** clears the cursor and loads it into non-volatile memory where it is retained indefinitely. With no cursor present, **NEXT** closes open menus in reverse order and returns the LCD to the most recent data display.

2.2 Channel Configuration Menus

Figure 2.1 illustrates the menu tree for configuring *Channel* variables. These items affect only the specific channel selected. *System* specific variables are in the menu tree shown in section 2.3.

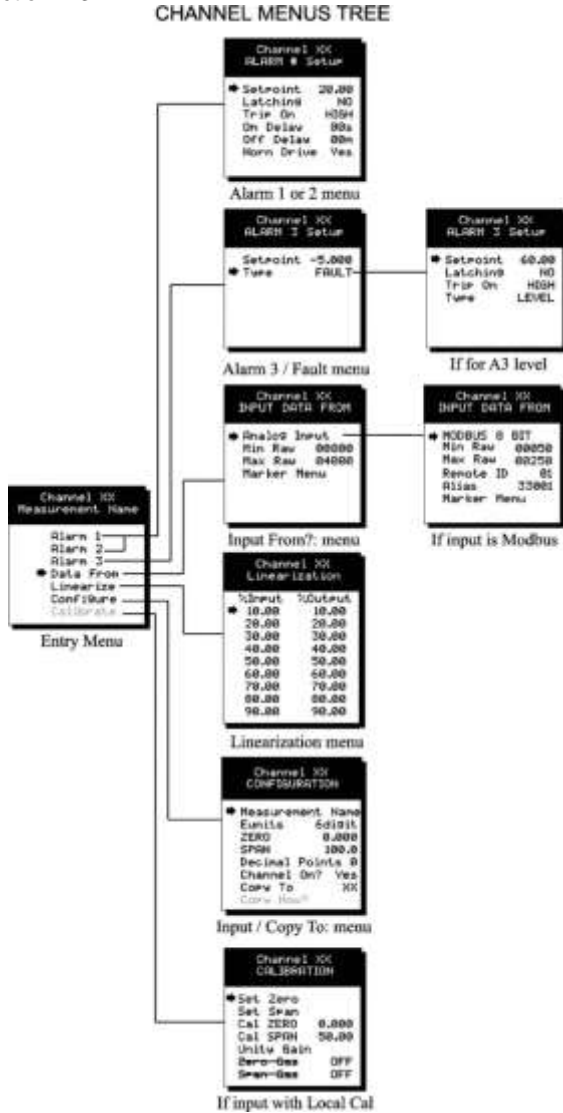

Figure 2.1

2.2.1 Channel Setup Entry Menu

The *entry menu* shown on the left side of Figure 2.1 allows access to all configuration variables for the selected channel. These are, **Alarm 1**, **Alarm 2**, **Alarm 3**, **Data From?**, **Linearize**, **Configure** and **Calibrate**.

2.2.2 Alarm 1 / Alarm 2 / Horn Relay Setup Menu

Alarms 1 and 2 are identical except A1 may not be *acknowledged* and front panel LED indicators are yellow while A2's are red. Since their configuration menus are the same, only one is shown in Figure 2.2 for clarity.

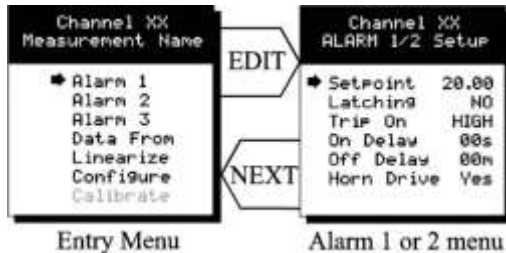

Figure 2.2

The first entry determines the **Setpoint** value where the alarm trips. It is entered in engineering units. For example, if a channel monitors 0-50 ppmH₂S and the alarm must trip at 10 ppm, the correct entry is 10.00.

- **Latching** determines either manual or automatic alarm reset operation. **YES** requires a manual **Alarm Reset** to unlatch the alarm even though an alarm condition no longer exists. **YES** also causes this alarm group's common relay, front panel LED, and optional discrete relay to latch. **NO** allows all outputs for this alarm to automatically reset as soon as the alarm condition clears.
- **TRIP ON** is set to **HIGH** for increasing alarms or **LOW** for decreasing alarms to determine if the alarm activates upon exceeding or falling below the setpoint.
- The **ON DELAY / OFF DELAY** entries allow **ON** and **OFF** time delays affecting how long the setpoint must be surpassed before an alarm event transition occurs. **ON** delays are limited to 10 seconds while **OFF** delays may be as long as 120 minutes. Delays are useful in many applications to prevent nuisance alarms and unwanted cycling into and out of alarm conditions.
- The **HORN ON** entry allows linking this alarm to the common horn relay. **NO** causes the alarm to have no effect upon the horn relay. Entering **YES** causes this alarm to turn the horn relay on steady, or, to pulse it depending upon horn configuration in the system menu (see section 2.3.1).

Discrete LED indicators on the front panel indicate the status of each alarm and relay. Any *new* alarm event causes the associated LED to flash until **Alarm Reset** occurs causing an *acknowledged* steady on condition. Operators should recognize *new* alarms by a flashing LED. **Alarm Reset** also *acknowledges*, or deactivates, the horn relay until another new alarm occurs.



All relays are rated at 5 Amp for 28 VDC and 250 ~VAC **RESISTIVE** loads. **IMPORTANT:** Appropriate diode (DC loads) or MOV (AC loads) snubber devices must be installed with inductive loads to prevent RFI noise spikes. Relay wiring should be kept separate from low-level signal wiring.

2.2.3 Alarm 3 / Fault Alarm Menu

The discrete channel alarms identified as Alarm 3/Fault may be configured either as a 3rd level alarm, or, as a Fault alarm indicating the input is out of range in the negative direction. When used as a level alarm, features such as on / off delays, latching and trip direction are also available. It is important to understand that though discrete channel alarms (LED's & optional discrete relays) may be set as Alarm 3 level alarms, the common relay for this group is always a Fault alarm. The fault *out of range* threshold for the channel is the most recent Fault trip point entered prior to changing the menu to Alarm 3. The following example describes how to configure both the Fault *out of range* and Alarm 3 *level* trip points for a channel. **Example:** If the common Fault relay must trip as the input falls below negative 10% of full scale, and, the discrete alarms trip as the input exceeds a level, then the -10% Fault setpoint must be entered first. Toggle the *TYPE* menu entry to **FAULT** and enter -10.00% into the *setpoint* entry. Next, toggle the menu back to **LEVEL** and enter the desired Alarm 3 level *setpoint*. The -10% Fault value is retained in memory even though it no longer appears on the menu.

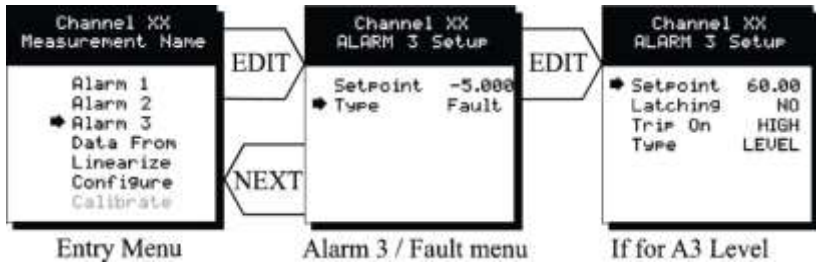

Figure 2.3

2.2.4 Data From? Menu to Set Input Source

Channels may be independently configured to accept input data from the following sources (also see Figure 2.4):

- An analog input PCB attached to the I²C bus.
- A sensor input PCB attached to the I²C bus.
- The ModBus RS-485 master port connected to ModBus slave devices.
Note: Each *ModBus* menu selection also requests the RTU # and the Alias register # location of the data to be retrieved from the RTU. Alias register numbers define the location of the variable representing the input value and must be obtained from the manufacturer of the ModBus RTU device.

- Our 10-0288 Radio Modem may be connected to the ModBus RS-485 master port to enable wireless communication to OLCT 200 wireless sensor transmitters.

EDIT toggles the *Data From* entry between *Analog*, *Analog with Local Cal* or *Sensor Direct*, *WIRELESS RF900* and *ModBus RTU* (signed, unsigned & floating point).

Analog should be selected when the channel's input comes from a transmitter or monitoring device with a **calibrated** output such as 4-20mA. *Analog with Local Cal* is available when the WX16 will be the point of calibration for the analog input. *Sensor Direct* is identical to *Analog with Local Cal* and both activate the WX16's *Cal Mode* features (see section 2.2.7). Problems may arise if calibrations are performed in two places upon the same signal, so *Cal Mode* menus are only visible when *Sensor Direct* or *Analog with Local Cal* is selected. These selections should only be used when the input originates from a **non-calibrated** signal source such as the *Bridge Sensor Input* option described in section 3.1.3. These applications require the WX16 to be used as the calibration point, since the sensors have no *zero* or *span* controls.

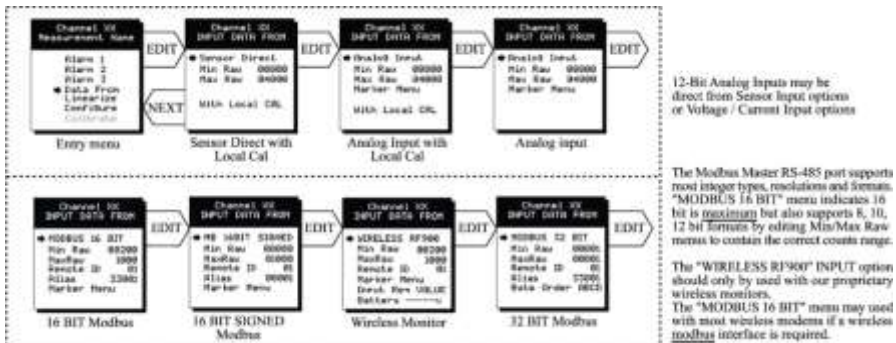

Figure 2.4

2.2.4.1 Min / Max Raw Counts Menus

The Min Raw and Max Raw counts entries included in Input Data From: menus define the range of input counts that provide *Measurement Range* read-out values described in section 2.2.6b. This menu entry is determined by the A/D converter resolution of the channel's input. For example, if the input is a 10 bit ModBus device with zero at 200 counts and 100% at 1000 counts, then this menu's MIN should be set at 200 and MAX at 1000. If communicating with the WX16's optional 12 bit Analog Input PCB, the MIN should be 800 and the MAX 4000.

If the input device's resolution is unknown, the live counts variable on the bottom of the screen displays actual raw A/D counts currently being read by this channel. This reading may be used to test the input device for what A/D counts are provided for zero and 100% if these values are unknown. Forcing the input device to read zero should provide the A/D counts value needed to make this channel's display also read zero. Likewise, forcing the input device to read 100% should provide the A/D counts value needed to make the WX16 channel's display also read 100%.

If ModBus 32 BIT is selected, a Byte Order entry appears at the bottom of the menu. This determines WORD and BYTE alignment of data at the remote ModBus transmitter when sending its 4 byte IEEE Floating Point values. With the pointer on this entry, the EDIT key toggles between the 4 possible modes. Min / Max Raw values are not used in this mode.

Note Each *Data From:* item has a matching default Min/Max counts value of 20% to 100% with $\pm 5\%$ over/under range applied. If the default value is incorrect for the input device it should be edited.

2.2.4.2 Marker Menu

Some transmitters or monitoring devices providing WX16 inputs also indicate special modes of operation, such as *Calibration, Maintenance or Fault*, by transmitting a special <4mA or negative “Marker” value. The WX16 offers channel Marker menus for detecting and indicating such events (see Figure 2.5). While active, the WX16 displays a 6-digit ASCII message to indicate the special event, and if equipped with 10-0167 4-20mA output option, the WX16 also transmits the same <4mA value.

- **Marker Enabled** turns the marker feature ON and OFF
- The negative Marker value is entered into the **Marker %** field as a negative percent of full scale. For example, -15.62% of full scale detects a marker value of 1.5mA (1.5mA is -15.62% of full scale when 4-20mA is the range).
- The **Mark As** menu allows user entry of the 6-digit ASCII message to be displayed when the marker is detected.

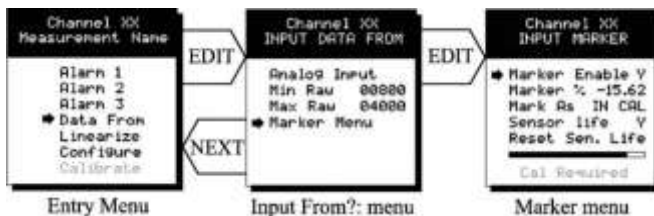

Figure 2.5

2.2.4.3 Sensor Life Detection

Sensor Life should only be activated when the Marker event is *Calibration* and when a sensor life value is transmitted after each calibration. This feature is provided primarily for use when interfacing the WX16 to Oldham’s OLC200 Transmitters, which may be configured to transmit sensor life values after each calibration (see Figure 2.6). For **Sensor Life** to record properly, the monitor must perform as follows: After the *Calibration* Marker interval, 4.0mA transmits for 10 seconds to indicate its *calibration mode* is complete. The monitor then transmits between 4.0mA and 5.0mA for five seconds depending on remaining sensor life where 4.0mA = 0% and 5.0mA = 100% remaining sensor life. The WX16 reads this value and records it as the channel’s **Sensor Life**. **Sensor Life** is stored in the WX16 ModBus database and displayed as a

bar-graph in the Sensor Info screen (see section 2.3.6). It is a useful tool for planning sensor replacement schedules.

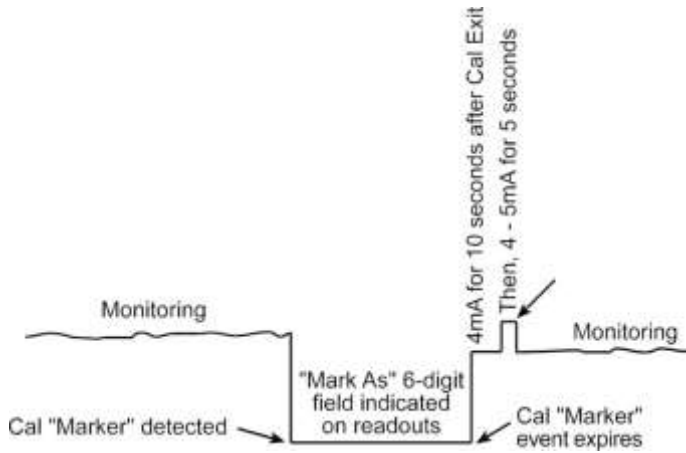

Figure 2.6

2.2.5 Linearization Menu

The linearization menu allows each channel to have its own linearization curve stored in the controller's non-volatile memory. Input versus output points must be entered in *percent of full scale* values. This means if the range is 0-200 ppmH₂S, then 100 ppm is 50% of full scale. Zero input will provide a zero output and 100% input a 100% output. Nine intermediate points may be entered to define the curve.

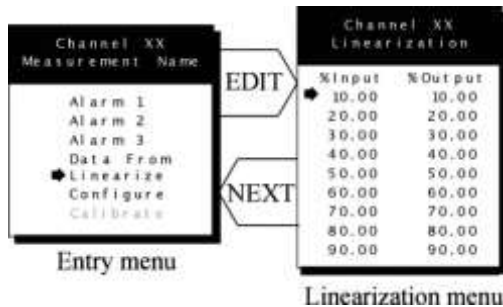

Figure 2.7

2.2.6 Configure Menu

From the entry level setup menu in Figure 2.8, the CONFIGURE menu may be entered for setting variables defining how the controller presents monitored data to the various graphic displays.

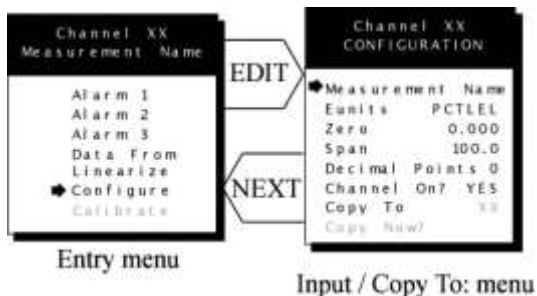

Figure 2.8

2.2.6.1 Eunits / Measurement Name ASCII Data Fields

The first two items in this menu are for entering the 6 character *engineering unit* and 16 character *Measurement Name* ASCII fields. Eunits should define the units of measure for what this channel is to display. *Measurement Name* should describe the source of this data in the user's terminology. Section 2.1.1 of this manual describes how to use the front keypad to modify these fields.

2.2.6.2 Input Measurement Range

The **ZERO / SPAN** entries allow configuration of the measurement range displayed by this channel. Measurement Range works along with *A/D Counts* menus, described in section 2.2.4a, to define the range of the input signal's engineering units. For example, if a channel's input is 4-20mA from a transmitter monitoring 0 to 10ppm chlorine, then the **Zero** value should equal 0.000 and the **Span** value equal 10.00. The six ASCII engineering units previously entered are automatically displayed at the top of each menu as a reminder. Four digits must appear in this entry, so trailing 0's may appear here that are not displayed on other data screens.

2.2.6.3 Decimal Point Resolution

Resolution of displayed channel values is configured in this menu by setting the number digits trailing the decimal point. Values are limited to a maximum of four digits, and a polarity sign. An auto-ranging feature displays the highest resolution allowed by this menu's decimal point entry. For example, if three decimal points are entered, and the range is 0 to 100ppm, the reading will be **0.000** at 0ppm and **100.0** at 100ppm. However, this may be undesirable due to the high resolution at zero unless the sensor's output is extremely stable. If decimal points are limited to one, the 0ppm reading becomes **0.0** and the 100ppm reading remains **100.0**. Resolution may be limited further by setting decimal points to 0. In the above example, this would cause 0ppm to display **0** and 100ppm to display **100**.

2.2.6.4 Turning Off Unused Channels

The **Channel On?** entry determines if this channel is to be utilized. Turning it off will cause the controller to never process inputs applied to this channel and no alarms will be tripped or data displayed. Inactive channels have a line drawn through them on the Setup screen as indicated by channels 15 & 16 in Figure 2.0. If less than 9 channels are to be activated, the WX16 may be set for 8 channel mode, deactivating channels 9-

16. This is done in the System Setup menu described in section 2.3. The WX16 will only allow 15 channels to be turned off. At least one channel must remain on

2.2.6.5 Copy Data To?

This menu simplifies the Setup procedure by allowing similar channels to be copied from one to another. For example, if all channels are identical except for the *Measurement Name* entry, channel 1 could be configured and copied to channels 2 – 16. Only *Measurement Name* then must be configured on channels 2 – 16. Use **EDIT** to increment channel numbers and **UP/DN** to point to **Copy Now?** Press **EDIT** once more to copy.

2.2.7 Cal Mode

IMPORTANT! Each channel's **CALIBRATION** menu is **inactive** unless its *Input Data From:* menu, described in section 2.2.4, is set for *Analog with Local Cal* or *Sensor Direct*. WX16 CAL MODE features allow pushbutton calibration of zero and span values. This feature should be utilized only when there are no other zero/span controls within the monitoring system, since it is inappropriate to calibrate a signal at more than one point. Therefore, if calibration is to be performed at another transmitter or monitoring device, the WX16 CAL MODE feature should not be used.

The CALIBRATION MENU allows entering the correct **Cal ZERO & Cal SPAN** set-point values needed to calibrate the sensor. These are entered in the same engineering units as input range. **Set Zero & Set Span** controls in this menu allow pushbutton calibration by moving the pointer to each and pressing the **EDIT** key. A live reading of the channel's value allows calibration checks to see if an adjustment is needed. Unintentional calibrations are reset by the **Unity Gain** menu item. **Unity Gain** resets zero offset to 0 and span gain to 1. It is useful for returning the calibration to a known starting place. Sensor aging may be monitored by recording zero and span readings at **Unity Gain** when it is new, and again at later dates when degradation may have occurred.

To check zero calibration, apply the ZERO calibration value to the sensor and observe the live reading. If the zero reading differs from the zero setpoint, a calibration is needed. To calibrate zero, move the pointer to **Set Zero** and press **EDIT**. A warning message explains that pressing **EDIT** again will change the zero calibration and any other key will exit. The procedure for span calibration is identical. For example, if an LEL combustible sensor is to be spanned with 50% LEL span gas, the span set-point must be 50%. If 45% LEL is to be used later, the span set-point must be changed to 45% to match the span calibration gas. If the reading is only 40% LEL with the 50% gas applied a span calibration is needed. Move the pointer to the **Set Span** entry and press **EDIT** twice. **Unity Gain** may be used at any time to cancel incorrect calibrations and start again.

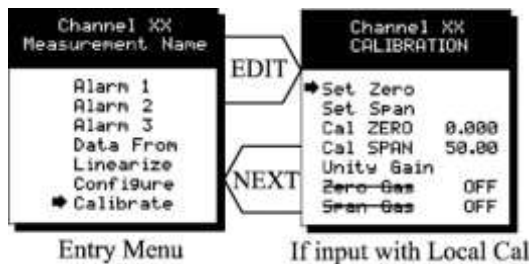

Figure 2.9

2.3 System Configuration Menus

Some items needing configuration are not specific to a channel but affect the entire WX16 system. These are located in the system entry menu shown on the left side of Figure 2.10. System menus are accessed by pointing to the desired item and pressing **EDIT**.

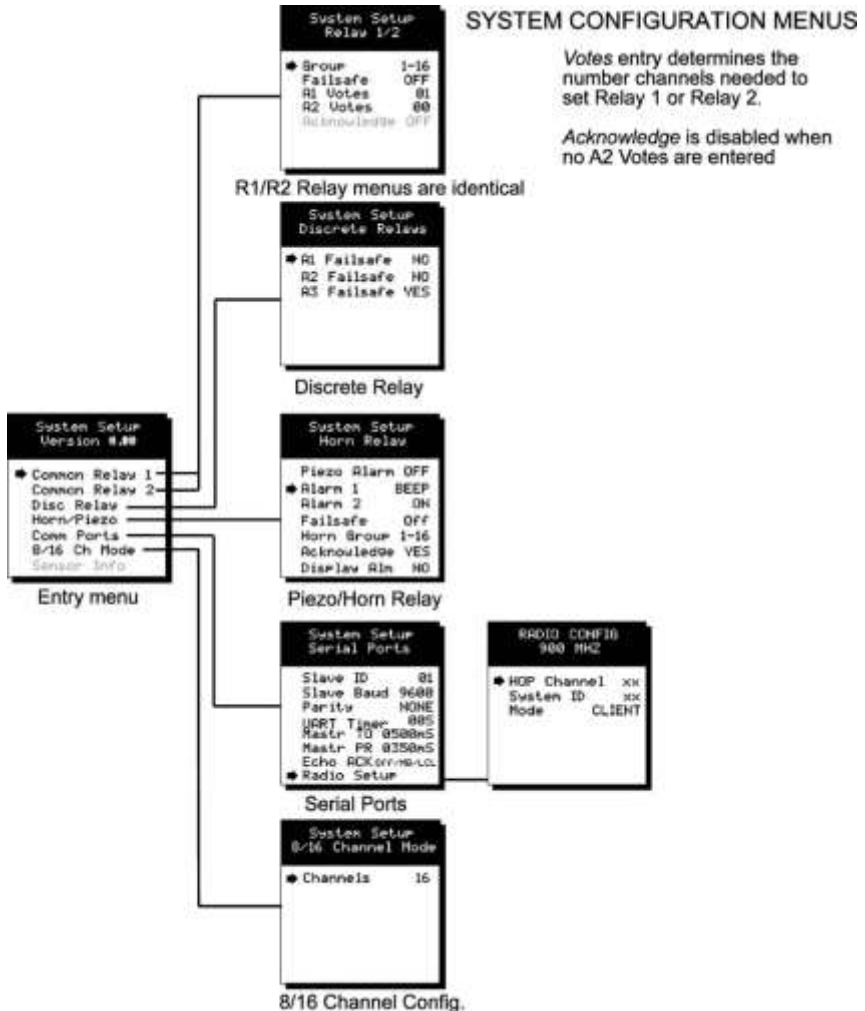

Figure 2.10

2.3.1 Common Alarm Relays 1 & 2



READ THIS SECTION CAREFULLY AND TEST ALL SETTINGS BY SIMULATING WX16 INPUT CONDITIONS THAT SHOULD ACTIVATE THESE ALARM RELAYS!

Common Relay 1 & Common Relay 2 menus are identical and therefore discussed only once. It is very important to fully understand these menus, since they determine the functions of each common relay.

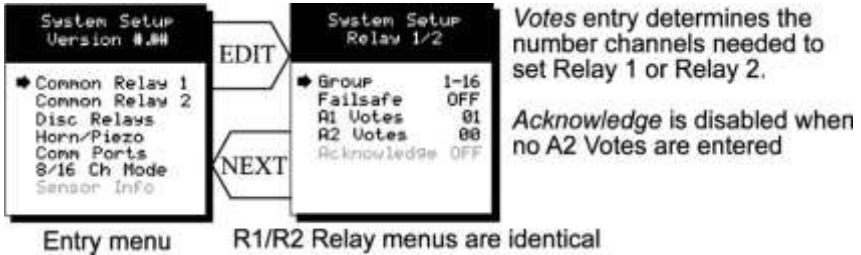

Figure 2.11

- The **Group** menu entry offers additional flexibility by controlling which channels trip this menu's common alarm relay. The 3 choices are **1-16**, **1-8** or **9-16**. Some applications have different types of sensors, or, sensors in different areas connected to the same WX16 Controller. In these cases, it may be undesirable for a sensor on channel 9 to trip the same relay as a sensor on channel 2. The **Group** menu may restrict this. For example, channels 1-8 might be set to trip common relay 1 while channels 9-16 trip common relay 2. Another possibility is channels 1-8 be set to trip common relay 1 while channels 9-16 trip relays on an optional discrete relay PCB configured for Alarm 1 (see section 3.2).
- **Failsafe** controls relay activation for this common relay. **Failsafe ON** causes the relay to de-energize during alarm conditions and energize when there is no alarm. Thereby, a power failure forces the relay contact to the alarm position. Note the common Fault relay is always failsafe and may be monitored separately to indicate loss of power conditions in many applications.
- **A1 and A2 Votes** allows creation of logical AND function equations that control common relay 1 & common relay 2. Default settings for common relay 1 are **A1 Votes = 01** and **A2 Votes = 00**, which cause relay 1 to trip if any channel has an A1 level alarm active. Default settings for common relay 2 are **A1 Votes = 00** and **A2 Votes = 01**, which cause relay 2 to trip if any channel has an A2 level alarm active. Example: If either default setting is modified such that **A1 Votes = 02** and **A2 Votes = 01**, then any two channels must have an A1 level alarm active and any one channel must have an A2 level alarm active to trip that relay. REMEMBER! One of the A1's and the A2 could be on the same channel. These level alarms must come from a channel included in the **Group** entry described above.

- Turning **Acknowledge ON** (not available on Alarm 1) allows the common relay to be deactivated during alarm conditions by an **Alarm Reset**. This is useful if an audible device is being driven by the relay.



All relays are rated at 5 Amp for 28 VDC and 250 ~VAC **RESISTIVE** loads. **IMPORTANT:** Appropriate diode (DC loads) or MOV (AC loads) snubber devices must be installed with inductive loads to prevent RFI noise spikes. Relay wiring should be kept separate from low-level signal wiring.

2.3.2 10-0195 Discrete Relay “Failsafe” Mode

10-0195 Discrete relay options may also be configured to function in a *Failsafe* mode using the System Setup menu shown in Figure 2.12. Entering YES causes these discrete relays to have energized coils when no alarm condition exists for the associated channel and de-energized coils when the alarm occurs. *Failsafe* is useful for indicating failed relay coils and loss of power conditions. **Important: 10-0195 zoning jumpers (see Figure 3.4) should not be used when Discrete Relays menus are set for failsafe.** Zoning jumpers cause ANY relay in the zone to energize ALL other relays in the same zone. Zoning of failsafe relays may be accomplished with wiring at the relay contact terminals.

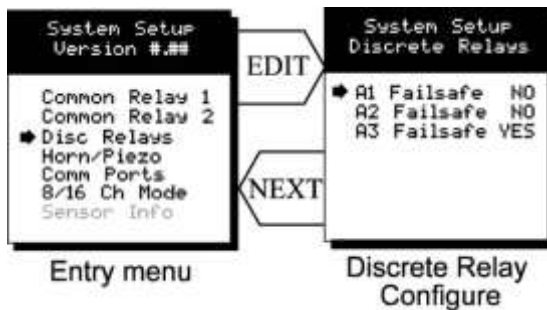

Figure 2.12

2.3.3 Common Horn Relay & Local Piezo

The WX16 is equipped with a low-decibel audible piezo that chirps when keys are pressed and may be configured to audibly indicate alarm conditions. The common horn relay is similar to the common A1 & A2 common relays.

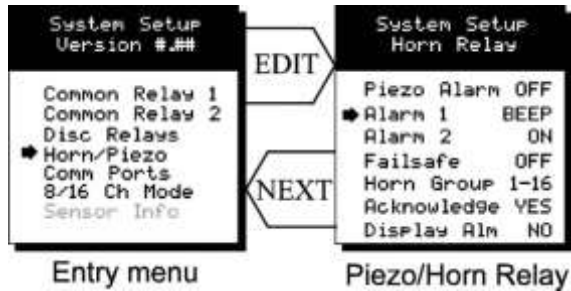

Figure 2.13

- Turning **Piezo Alarm ON** causes the audible piezo to duplicate the action of the horn relay. This feature may be used to provide a low-decibel indication of the status of the system's horn.
- **Alarm 1 & Alarm 2** menu control how this alarm level from each channel will affect the common horn relay. Choices are **OFF**, **ON** or **BEEP** (one Hz. Pulsating). As an example, A2 conditions might pulse the horn (**BEEP**) and A1 conditions to cause a steady horn (**ON**). Any other combination of these 3 choices is possible for A1 and A2 levels affecting the horn relay. This feature is very useful since it allows the horn relay to serve as another level A1, level A2 or both for channels 1-16, 1-8 or 9-16. Individual channel alarms may also be configured to not affect the Horn relay on a channel by channel basis (see section 2.2.2).
- **Failsafe & Horn Group** menu entries are identical to the descriptions for menus **Common Relay 1 & Common Relay 2** in section 2.3.1.
- Turning **Acknowledge OFF** allows the common Horn relay to drive devices other than horns or sirens, such as a light or a fan.
- **Display Alm YES** forces the LCD to display the Bar Graphs screen upon any new alarm. This feature is offered to satisfy applications requiring channels in alarm to be displayed automatically (all channels are displayed on the Bar Graphs screen).

2.3.4 Comm Port Menus

The system Comm Port menu allows setting RTU **Slave ID** address, **Slave Baud** rate, **Parity** and **UART Timer** for the comm2 *slave* ModBus serial port (comm1 *master* port ID settings are per channel as described in section 2.2.4). This slave port may be used to transfer WX16 data to a host device such as a PC, PLC, DCS or even another WX16. The slave port is addressable, allowing many WX16 controllers to be connected to a single RS-485 cable. The **UART Timer** setting is disabled with 00 seconds entered. Entering a value causes the comm2 *slave* ModBus serial port to reinitialize if no ModBus query is processed within this time period. This ensures against serial port lockup. Section 5 of this manual provides important information describing how to interface to the WX16's ModBus slave port.

The **Mastr TO** (master time out) and **Mastr PR** (master poll rate) menu items affect the WX16's *master* ModBus port. *Time out* sets length of time in milliseconds before a communications error. Three consecutive timeout errors must occur before a communication error is indicated. This item is useful for optimizing throughput to the WX16 from other slave RTU's. *Poll Rate* sets frequency of data requests to the RTU's in milliseconds. This is useful when an RTU is limited in how fast it may respond to consecutive data requests.

The **Echo ACK** (echo acknowledge) menu allows alarm reset / alarm acknowledge functions be sent from the ModBus master port to connected ModBus slave devices having ModBus coil 2001 assigned as the reset / acknowledge coil. This menu may be set to **OFF**, **LCL** (local) or **MB/LCL** (ModBus/local). Off disables the feature and 2001 coils of slave devices are unaffected. **LCL only** writes to the 2001 coils of connected RTU's when the local Reset pushbutton is pressed. **MB/LCL** writes these coils if this WX16's 2001 coil has been reset via modbus AND when the local pushbutton is pressed. The **MB/LCL** option is useful if WX16s are being cascaded from an HMI or other ModBus master. A short time delay between reset of remote RTU's and the primary WX16 may occur, since remote resets are processed first.



IMPORTANT! ALL MODBUS 2001 COILS ARE WRITTEN BY THIS FEATURE. DO NOT CONNECT DEVICES WITH 2001 COILS CONTROLLING OTHER CRITICAL EVENTS!

2.3.4.1 Master Port Radio Setup Menu



The radio kit option may be connected to the comm1 *master* port and receive wireless data transmissions from up to sixteen of Oldham's OLC200 wireless sensor transmitters. It is not possible to also use the comm1 *master* port to communicate to "wired" ModBus transmitters, and if any channels are set for ModBus, they will report "comm. error".

See Section 7 for a detailed discussion of WX16 wireless operation.

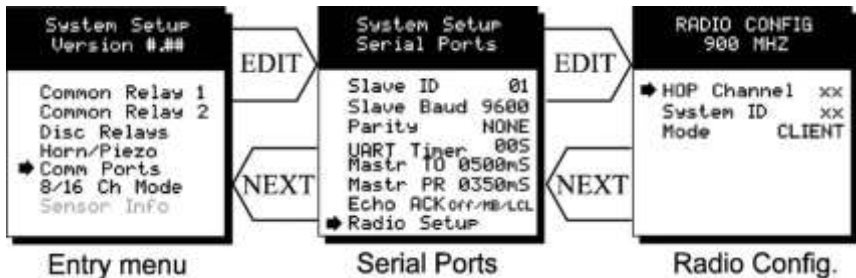

Figure 2.14

2.3.5 Eight / Sixteen Channel Modes

The system menu allows setting the WX16 controller to accept either 8 or 16 channels. If 8 channels are selected by this menu, they are channels 1-8, and 9-16 are disabled.

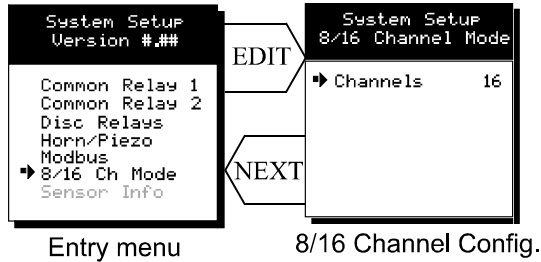

Figure 2.15

2.3.6 Sensor Information

Sensor Info is available when at least one channel has **Sensor Life** activated in the **Marker** menu (see section 2.2.4b). The **Sensor Info** screen displays each channel's sensor status as illustrated in Figure 2.16. Channels with **Sensor Life** disabled indicate **Option Disabled** above the corresponding empty bar graph. If **Sensor Life** is enabled, the channel will have its Measurement Name above the bar, or, an empty bar with a **Cal Required** label. **Cal Required** indicates no Calibration Marker value has been received by the WX16.

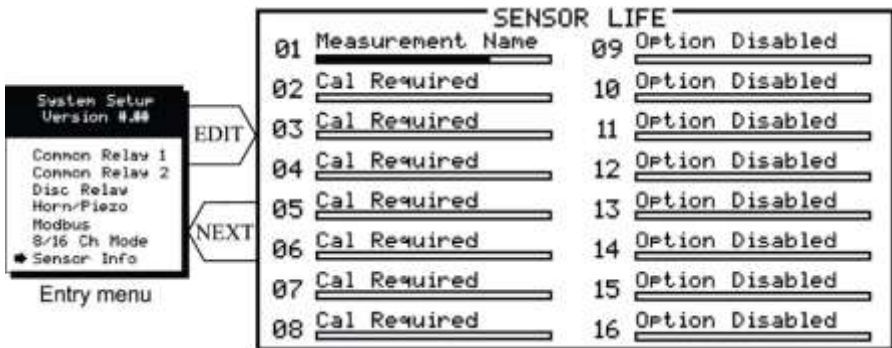

Figure 2.16

2.4 Authorization Mode

A password entered in the **AUTHORIZATION** menu allows locking all menus. *Viewing* menus is not denied, but attempts to *edit* variables flashes the **Locked** message on the LCD.

Authorized individuals locking the system should first enter a name, phone # or other contact information into the 10-digit field. To lock or unlock the system, the correct 4-digit authorization number must be entered into the **Enter Code** field. Point to the **Unlock System** menu entry and press **EDIT** to complete the unlock procedure.

It is very important to record the 4-digit code. However, if lost it may be displayed briefly at power up using the following procedure:

Remove power from the controller. Reapply power and as the alarm LED's begin scrolling down, hold the following keys simultaneously "UP", "DOWN", "NEXT", & "EDIT". Watch closely. The 4-digit authorization code appears briefly at bottom left of the screen.

IMPORTANT! DO NOT hold the keys before applying power since this causes a cold boot and returns all settings back to factory defaults.

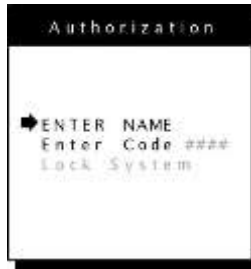

Figure 2.17

2.5 LCD Contrast Adjustment

The Setup menu item identified as **CONTRAST** allows users to adjust the LCD contrast to a level suitable to the ambient lighting. Selecting **CONTRAST** and pressing **EDIT** causes the **UP/DOWN** keys to increase and decrease LCD contrast.

SECTION - 3.

3.0 Main I/O Interface PCB #10-0142



The most basic WX16 Controller requires only the I/O PCB shown in Figure 3.1 for interfacing to field wiring. The WX16 primary power supply is applied to terminals 9 & 11 of TB2. This may be from 10 – 30 VDC. **WARNING! HIGH VOLTAGES SUCH AS 115 VAC APPLIED TO THESE TERMINALS MAY CAUSE SEVERE DAMAGE!** DC output terminals 10 & 12 on TB2 provide up to 500mA of output power for powering remote devices such as lamps, transmitters, etc.

This PCB includes both *master* (COMM 1) and *slave* (COMM 2) RS-485 ModBus ports, 5 amp form C relays for each common alarm event (A1, A2, FAULT/A3 & HORN), and power supply I/O terminals. JP1 allows the RS-485 ports to be configured for 2- or 4-wire operation. A 26-pin ribbon cable connects the I/O PCB to the WX16 CPU and Display nest assembly. Two I²C bus connectors allow addition of optional functions such as analog I/O and discrete alarm relays for each channel.

Horizontal jumpers installed in JP1 connect the RS-485 port's RX & TX lines, simplifying 2-wire daisy chains by providing additional terminals for incoming and outgoing cables. For example, installing the 2 COM 1 jumpers connects screw terminals 1 & 5 and terminals 3 & 7. Socketed RS-485 terminating resistors R6 (COMM 1) and R12 (COMM 2) are located on the MAIN I/O board. These resistors should be removed if communication wire lengths are very short (less than 25 feet) or if the port is not at the end of the communication line.

An optional Auxiliary Relays *piggyback* PCB (part #10-0144) may be added to the I/O PCB via ribbon cable J4. These add another form C contact set to the common A1, A2 and HORN alarms. Auxiliary Relay contacts are available at the TB1 (AUX) terminals shown in Figure 3.1.

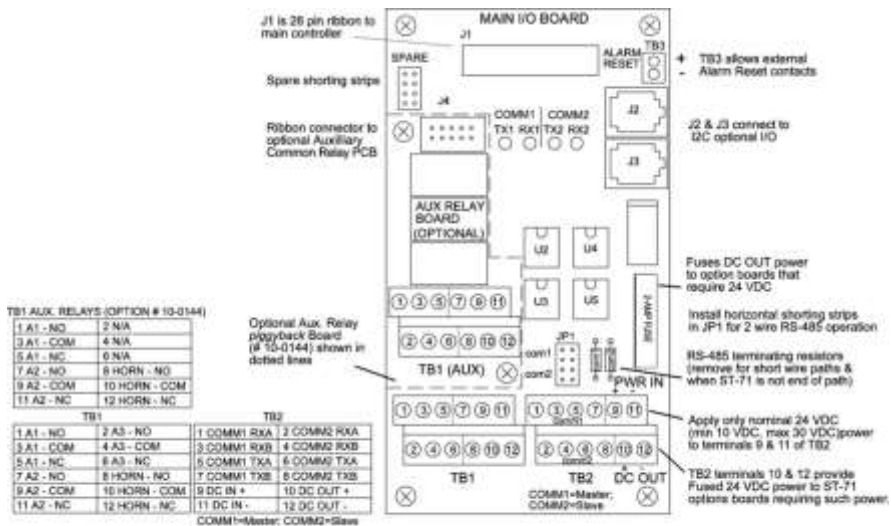

Main I/O PCB WITH COMMON RELAYS #10-0142

Figure 3.1

3.1 Input / Output Optional PCB's

Telephone style RJ11 connections are used to add optional 8 channel analog and digital I/O. A screen appears briefly after power up indicating what options are connected and for which channels. This information is also available from the *Diagnostics Mode* described in Section 4.

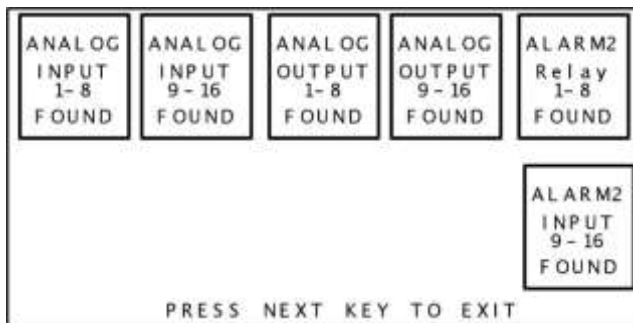

Figure 3.2

3.1.1 Optional Analog Input PCB #10-0158

Many transmitters or sensors have analog output signals, and the 12 bit *Analog Input PCB*, shown in Figure 3.3, is available to accept these. TB1, with 24 positions, offers 3 terminals per channel for distributing power and receiving analog inputs. These are

EXC and **HI / LO** inputs. TB2, with only two positions, is for connecting the power supply for powering external transmitters. Precision 100 ohm resistors (R1 – R8) between each channel's **IN LO** and **IN HI** terminals are socketed termination resistors for 4-20mA inputs. These may be removed if voltage inputs are to be applied.

EXC and **IN LO** terminals are bussed together internally. **EXC** terminals are tied directly to TB2-1 (+) and **IN LO** terminals are tied to TB2-2 (-). Bussing allows transmitter power to be brought into the system at a single point (TB2) and distributed back out at each channel's **EXC / IN LO** terminals to simplify field wiring. Figure 3.3 includes typical wiring to 2- & 3-wire 4-20mA transmitters.

JP1 determines if the 8 analog inputs are applied to channels 1-8 or channels 9-16. Connecting more than 8 analog inputs requires 2 PCB's with one JP1 set for channels 1-8 and the other set for channels 9-16.

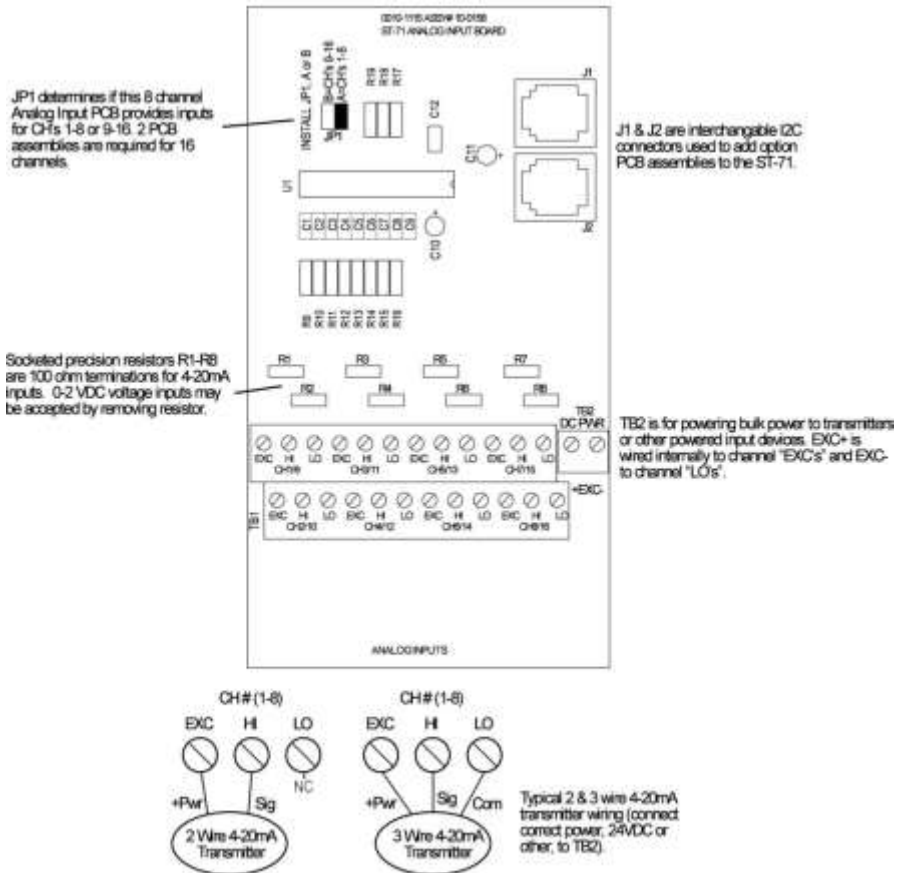

8 Channel Analog Input Option #10-0158

Figure 3.3

3.1.2 Optional Discrete Relay PCB #10-0195

An optional *Discrete Relay PCB*, shown in Figure 3.4, adds eight 5 amp (resistive) form C relays per sixteen channel alarm group (2 PCB's required when utilizing more than 8 channels). Each PCB may be configured via rotary switch S1 to function for ALARM 1, ALARM 2 or ALARM 3/FAULT for channels 1-8 or 9-16. A 1-minute time delay after power is provided to inhibit relay actuation until the system has had time stabilize. Alarm groups, or zones, may be created by connecting adjacent channels together using JP4 as shown. This creates a wire *OR* function with selected channels, causing *any* alarm included within the zone to actuate *ALL* zone relays. *Failsafe* operation of 10-0195 discrete relays may be programmed in the *system* menu as described in

section 2.3.2. Many WX16 applications utilize the common alarm relays (see section 3.0) and do not require discrete relays for each of the 48 alarm events (16 A1's, 16 A2's & 16 A3's). If discrete relays are needed for all 48 alarms, then six PCB's are required.

5 VDC power to the discrete relay option PCB's is normally supplied from the WX16 Controller via the slender I²C cables connected to J2 and J3. However, I²C cables are limited in ability to carry this power further than a few feet without a significant voltage drop. Some WX16 applications with relays for all 48 alarms may require up to 6 boards. TB2 allows a heavier 5 VDC power cable to be connected from terminals on the back of the WX16 front panel assembly, bypassing the I²C cable. A 20AWG pair connected to only one of the several TB2's is sufficient when these boards are in close proximity to each other.



All relays are rated at 5 Amp for 28 VDC and 250 ~VAC **RESISTIVE** loads. **IMPORTANT:** Appropriate diode (DC loads) or MOV (AC loads) snubber devices must be installed with inductive loads to prevent RFI noise spikes. Relay wiring should be kept separate from low-level signal wiring.

TB2 is used to supply external 5VDC power to Alarm boards when they are mounted > 5 feet from the controller. I2C cables provide 5VDC but losses occur with longer cable lengths.

WARNING: Voltages exceeding 6 volts may cause extensive damage to entire controller.

Standard configuration has a 1 minute POWER ON time delay preventing relay actuation during the delay. SB1 increases delay time to 8-minutes. SB2 removes all time delay.

S1 controls if discrete relays are tripped by A1, A2, or A3 alarms for Ch's 1-8 or 9-16. See Chart.

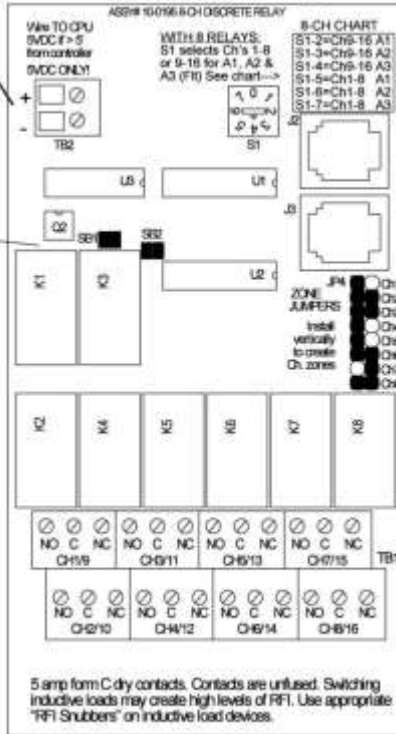

J2 & J3 are interchangeable I2C connectors used to add option PCB assemblies to the controller.

J4 allows "zoning" of adjacent channel alarms. All zoning jumpers are placed vertically. Dwg. exhibits channels 1-4 and channels 5-7 creating 2 zones. All relays in a zone switch together. Unused jumpers may be stored horizontally.

8 Channel Discrete Relay Option #10-0195

Figure 3.4

3.1.3 Optional *Bridge Sensor Input Board #10-0191

An optional 8-channel, 12 bit *Bridge Sensor Input* board allows these popular gas detectors to be connected directly to the WX16 without additional signal conditioning or transmitters. Up to four dual channel 10-0192 modules may be installed in each 8-channel 10-0191. Each 10-0192 channel is equipped with a bridge amplifier and balance potentiometer and an adjustable switching regulator for setting the correct sensor excitation voltage. A 3 position coarse gain jumper allows setting the gain of the bridge amplifier. Fault supervision circuitry forces the WX16 into a FAULT condition upon sensor failure or removal.

This option may also be configured to accept 4-20mA inputs for mixing bridge sensors and current loops into the same board. Placing any channel's 2 position LEL/4-20mA

jumper into 4-20mA position and installing the associated precision 100 ohm socketed resistor allows 4-20mA signals to be applied to its C & A terminals. The 10-0192 sensor modules are not required for channels accepting 4-20mA.

Channels receiving input data from this board should have the *Data From*: menu set for *Sensor*, as described in section 2.2.4. This activates *Cal Mode* menus described in section 2.2.7 needed to *zero* and *span* sensor readings. After performing the one-time only *Initial Setup* as described below, all subsequent calibrations are by the WX16's electronic Cal Mode menus.

*Catalytic sensors connected directly to the WX16 should be limited to ranges of 0-1000ppm.

3.1.4 Catalytic Bead Sensor Initial Setup

Catalytic bead sensors vary widely in power requirements and sensitivity. It is therefore important to configure each channel to match the sensor with which it will operate.

-  Prior to connecting sensors, apply power to the system. Note this PCB requires 24 VDC power be connected to its TB2 terminals 1 & 2 as shown in Figure 3.5. Suitable fused power is available from the Main I/O board's TB2 terminal 10 & 12 (see Figure 3.1). Measure the voltage between each channel's A and R terminals and set the *Voltage Adjust* potentiometers for the correct sensor excitation voltage. This may range from 1.5 volts to 7.5 volts depending upon sensor specifications. **Sensors may be damaged by accidental over voltage conditions. It is recommended the *Voltage Adjust* potentiometer screws be covered by a dollop of RTV or similar material after completion of this procedure to avoid accidental over-voltage conditions.**
- Remove system power and connect sensor wires to the R-C-A terminals. Reapply system power and confirm correct voltage across each sensor's A & R terminals. Note: If sensor wires are long, it may be necessary to measure the excitation voltage at the sensor end to compensate for I^2R losses in the wiring.
- With the minus voltmeter lead on TB2-2 (common), connect the plus lead to the channel's test point. With zero air on that sensor, adjust its *Balance* potentiometer for .4 volts at the test point.
- Apply 50% LEL combustible span gas to the sensor and allow the test point voltage to stabilize. Two volts = 100% input to the A – D Converter and .4 volts = 0%. Therefore, 1.2 volts = 50%. Place the 3 position *Coarse LEL Gain* jumper into the position which reads between .8 volts and 1.2 volts on the test point with 50% LEL gas on the sensor. Gain settings for each jumper position are as follows: no jumper = 1, LOW = 7, MED = 21, HI = 41. Multiple jumpers have an additive affect upon gain, so the LOW and MED jumpers together provide a gain of 28.

Initial setup is now complete and normally only requires repeating if a sensor is replaced. Final calibration of this channel may now be performed using the WX16's electronic Cal Mode feature described in section 2.2.1.

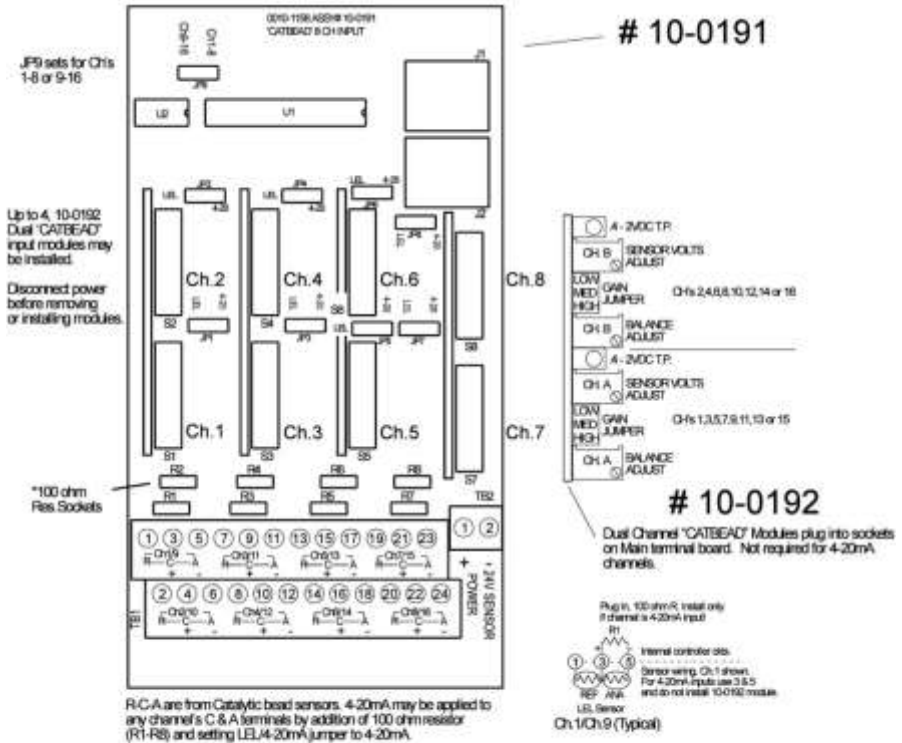

8 Channel "CATBEAD" Sensor Option #10-0191 / 10-0192

Figure 3.5

3.1.5 Optional RTD / 4-20mA Analog Input Board #10-0170

An optional 12-bit *RTD Sensor Input* board, shown in Figure 3.6, allows these popular temperature sensors to be connected directly to the WX16 without additional signal conditioning or transmitters. A 3-position range jumper allows setting the gain of the input bridge amplifier for the three popular ranges of 0-100°C, 0-200°C or 0-400°C. Other ranges are available by special order.

Inputs may also be configured to accept 4-20mA signals, allowing mixing RTD sensors and current loops into the same board. Two jumpers per channel determine either a RTD or 4-20mA input. These dual position jumpers, JP1 – JP16, must both be placed

into the UP position for RTD inputs or both in the DOWN position for 4-20mA inputs (see Figure 3.6).

Channels receiving input data from this board should have the *Data From:* menu set for *Sensor*, as described in section 2.2.4. This activates *Cal Mode* menus, described in section 2.2.9, needed to perform *zero* and *span* calibrations of RTD sensor readings. Each channel must be calibrated individually by either simulating desired zero and span calibration resistance values or by actually placing the channel's RTD into an actual precision temperature generator. Ice water is an acceptable method for generating the 0°C zero temperature value. Upscale span values are best simulated with an RTD calibrator. Since RTD's are stable and repeatable over long time periods, calibrations normally only need to be performed upon initial installation. Since the PCB has 8 channels, two are required for 16-channel applications. JP25 configures inputs for channel groups 1-8 or 9-16.

JP25 determines if this 8 channel RTD/mA input PCB accepts inputs for CH's 1-8 or 9-16. 2 PCB assemblies are required for 16 channels.

JP1 - JP6 work with JP9 - JP16 to determine if a channel accepts a resistive input or a 4-20mA input. JP17 - JP24 select 1 of 3 ranges for resistive inputs only.

Resistors R1 - R8 are socketed 100 ohm terminating R's for 4-20mA inputs and 100 ohm platinum RTD's (100 ohm for 0°C low range).

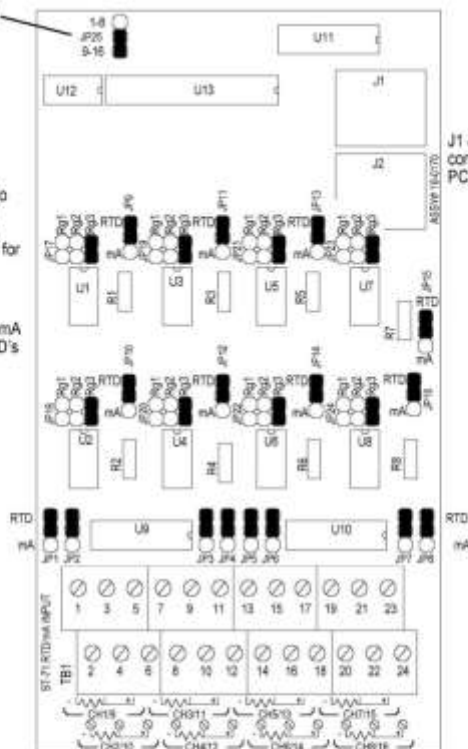

J1 & J2 are interchangeable I2C connectors used to add option PCB assemblies to the ST-71.

Input wiring options (Ch 1 shown, typical for all other Ch. s)

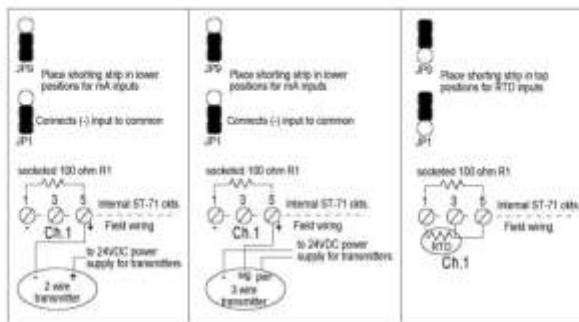

8 Channel Resistive / 4-20mA Input Option #10-0170

Figure 3.6

3.1.6 Optional 4-20mA Analog Output Board #10-0167

An optional 10 bit 4-20mA analog output board, shown in Figure 3.7, may be connected to the I²C bus. Each channel's output will transmit 4mA for 0% readings and 20mA for 100% readings. Loop drive capability depends upon the level of the WX16's primary DC power supply. With at least 20 volts DC primary power, they are capable of driving 20mA through a 750 ohm load. Outputs are self-powered, and DC power should not be provided by the receiving device. Note: This PCB requires nominal 24 VDC power be connected to TB2 terminals 1 & 2 as shown in Figure 3.7. Suitable power is available from the WX16 Main I/O board's TB2 terminal 10 & 12 (see Figure 3.1).

Since the PCB has 8 channels, two are required for 16-channel applications. JP1 configures the outputs for channels groups 1-8 or 9-16.

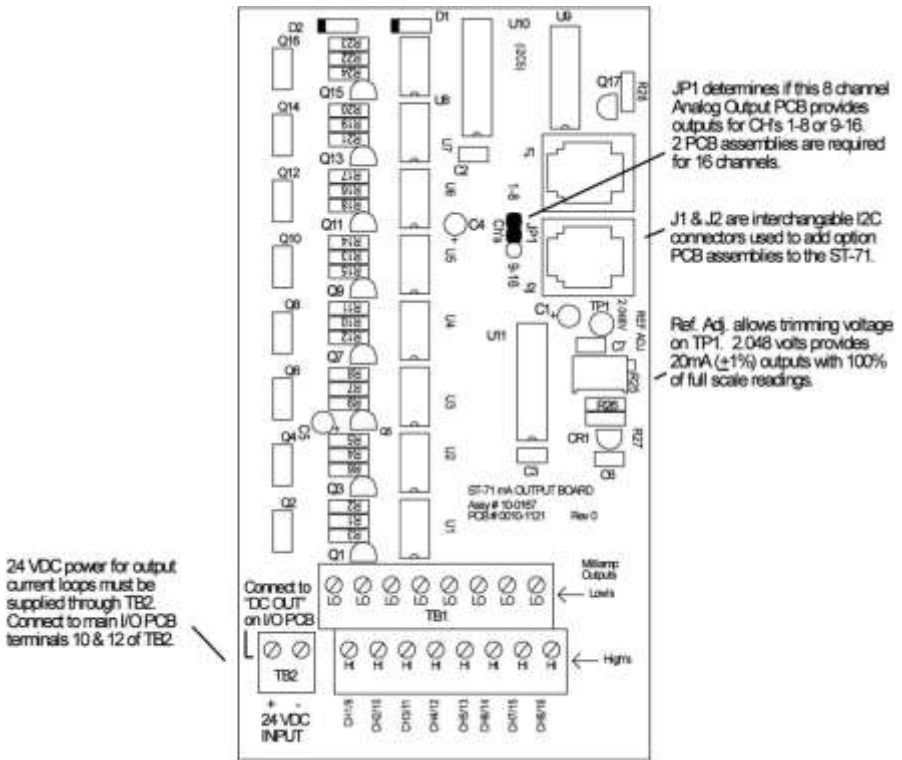

8 Channel 4-20mA Output Option #10-0167

Figure 3.7

3.1.7 Optional Clock / Printer Interface Board #10-0229

When equipped with the 10-0229 Clock / Printer Interface option, shown in Figure 3.8, the WX16 Controller is capable of automatically printing time & date stamped alarm events to a 24 PIN dot matrix printer such as the Panasonic KX-P1131. The cable interface between the WX16 and the KX-P1131 may be either parallel or serial. Parallel interfaces only allow 6 feet of separation, while the RS-232 serial interface allows up to 50 feet. Distances up to 4000 feet may be obtained using the 10-0229 printer interface option's RS-422 port but require an additional tri-port RS-422 / RS-232 converter at the printer end of the cable.

The 10-0229 Printer Interface may also be connected to a PC running HyperTerminal or other communications software as an alternative to hard copy printing of the data. Printer / PC cable schematics are shown in Figure 3.8. Printer settings for serial interfaces are 9600 baud, 8 data bits, no parity and one stop bit. Communications software settings are 9600 baud, 8 data bits, no parity, one stop bit and FlowControl = Hardware. Printer diagnostic red LED's indicate printer faults such as out of paper, overflowed buffer or loss of communications. Green LEDs flicker to confirm good communications between the WX16 and printer during print attempts.

Examples of printed alarm events are shown below. The format of each event, from left to right, is DATE, TIME, 16 character ASCII channel ID from the WX16, WX16 channel #, alarm #, IN or OUT status. A buffer in the WX16 retains the most recent 30 – 35 printed events. It is possible to dump the entire buffer to the printer from the menu shown in Figure 3.9. This is useful if printer problems have occurred causing missed printouts.

```
05/22/03 08:21:00 Storage Tank 103 Chnl 1 Alarm 2 IN
05/22/03 08:21:01 Storage Tank 103 Chnl 1 Alarm 2 OUT
05/22/03 09:12:01 Storage Tank 103 Chnl 13 Alarm 1 IN
05/22/03 09:13:00 Fuel A Flow Chnl 9 Alarm 1 IN
05/22/03 09:13:05 Storage Tank 103 Chnl 1 FAULT IN
05/22/03 09:13:05 Fuel Dock Chnl 2 FAULT IN
05/22/03 09:40:10 Storage Tank 103 Chnl 13 Alarm 2 IN
05/22/03 09:40:14 Fuel Dock Chnl 2 FAULT OUT
05/22/03 09:40:14 Trans Pump 103 Chnl 3 FAULT OUT
05/22/03 09:40:14 Storage Tank 103 Chnl 1 FAULT OUT
05/20/03 11:53:37 Fuel A Flow Chnl 9 Alarm 1 OUT
```

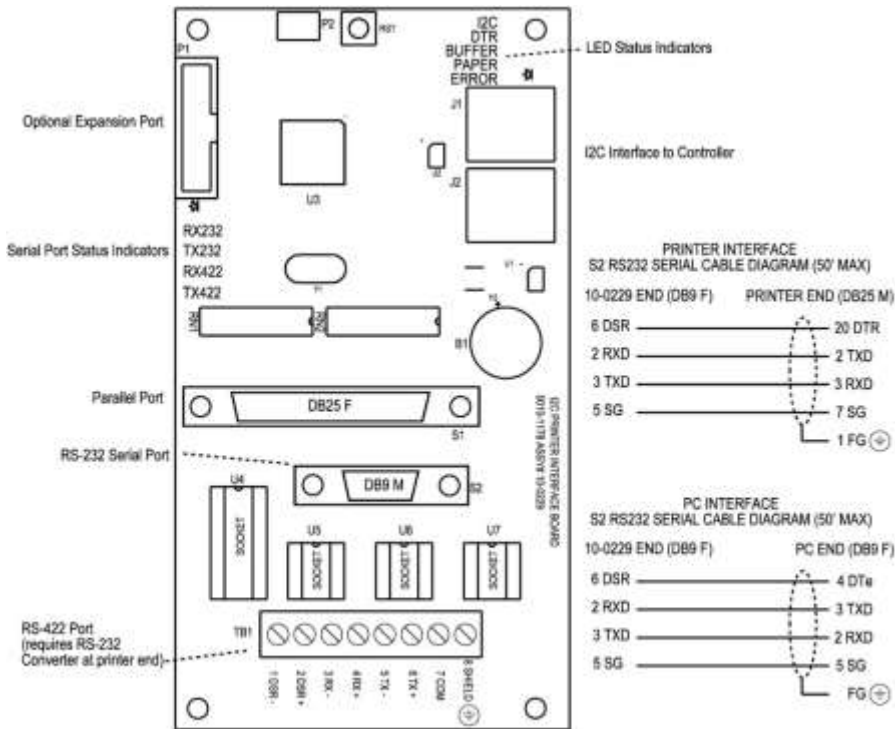

PRINTER INTERFACE OPTION # 10-0229

Figure 3.8

3.1.7.1 Clock / Printer System Setup Menu

Detection of the 10-0229 on the I2C bus causes the Clock / Printer System Setup menu item to appear. Selecting it and pressing EDIT brings up the menu shown at right in Figure 3.9. **Date / Time** menu entries allow setting of correct local time and date. The **ALARM PRINT ON/OFF** entry allows printing to be discontinued if turned to OFF. **PORT** allows selection of RS-232, RS-422 or the parallel port. With only one port able to be activated at a time. **BUFFER DUMP** allows immediate printing of all the 30-35 stored events. **PRINT CONFIG** allows immediate printing of all channel variables such as channel ID's, Engineering Units, etc. **PRINTER READY / ERROR** indicates the functional status of the printer.

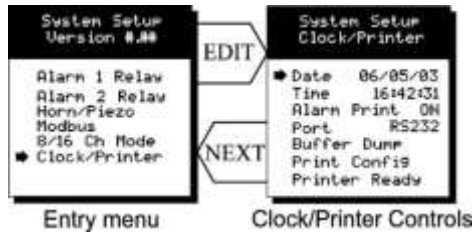
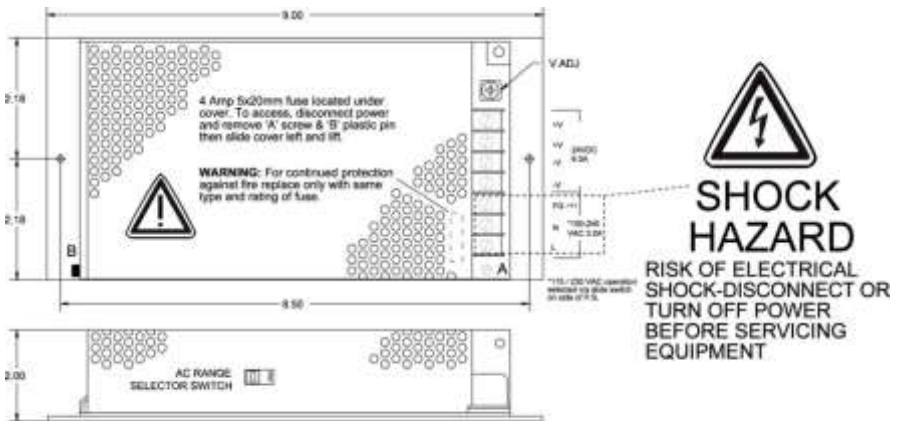

Figure 3.9

3.1.8 Optional 24 VDC 150 Watt Power Supply

The WX16 Controller may be powered from 10-30 VDC. However, many applications require 24 VDC power for the monitors or transmitters providing inputs to the WX16. A 150 watt AC / DC power supply may be included for these applications (115 VAC or 230 VAC selected via slide switch). When ordered from the factory, it is pre-wired to provide 24 VDC primary power for the WX16 controller as well as any transmitters or monitors that may be connected by the end user.



150 Watt 24 VDC Power Supply Option # 10-0172

Figure 3.10

SECTION - 4.

4.0 System Diagnostics

A *System Diagnostic Mode* shown in Figures 4.1 and 4.2 may be entered during normal operation from the Setup menu. The entry menu indicates firmware revision and offers useful routines for testing front panel LED's, relays, serial ports and analog I/O. It is exited manually by pressing **NEXT** and automatically if no keys are pressed for 5 minutes. It is very important to understand that **CHANNEL INPUT DATA IS NOT**



PROCESSED DURING THE DIAGNOSTICS MODE. It is possible to miss important input values while utilizing this mode and appropriate safeguards should be in place. However, the Diagnostics Mode can prove invaluable when testing I/O since relays and analog outputs may be stimulated without driving inputs to precise levels.

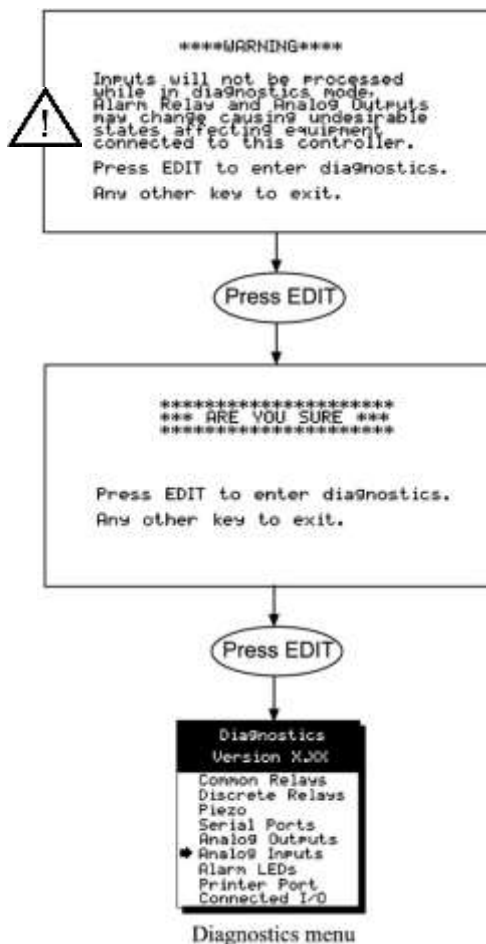

Figure 4.1

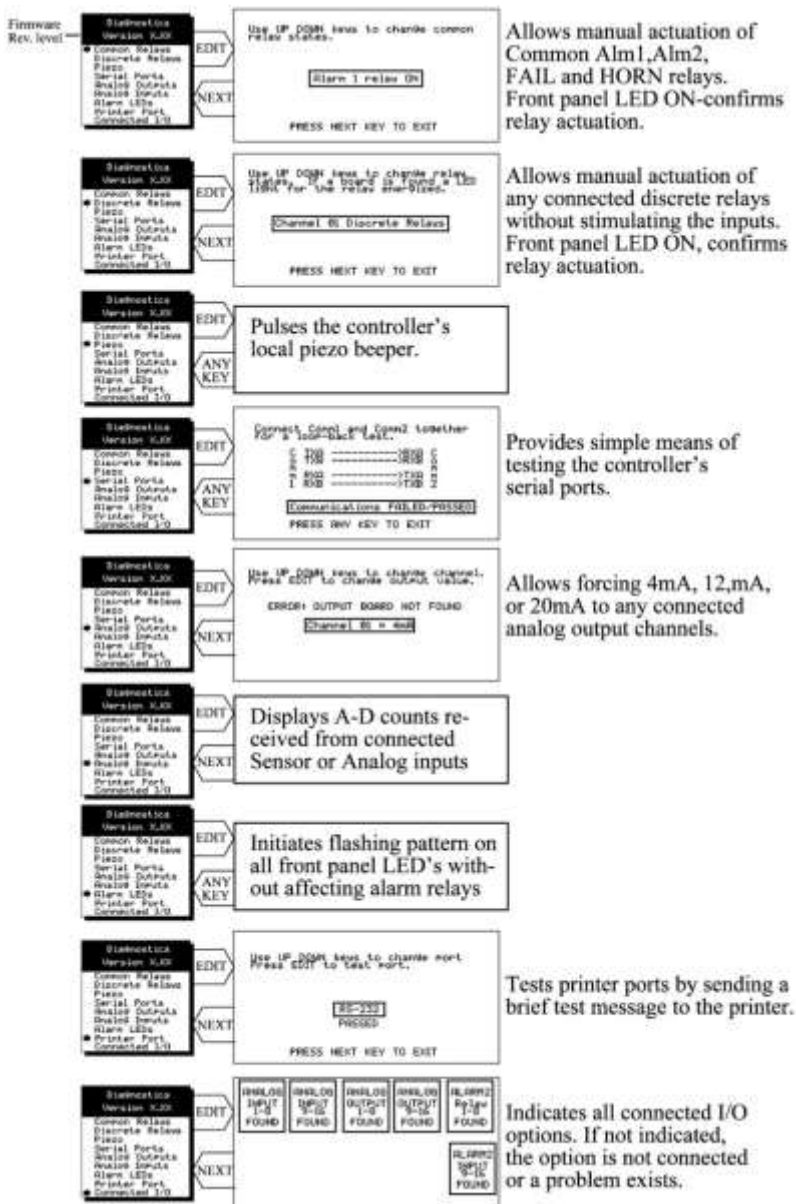

Figure 4.2

SECTION - 5.

5.0 ModBus RS-485 Ports

The WX16 is equipped with *Master* (COMM 1), and *Slave* (COMM 2), ModBus RTU ports. Port configurations are described in sections 2.2 and 2.3 of this manual. Section 5.0 defines register locations of data available via the WX16 slave port.

5.1 ModBus Slave Register Locations

The following tables describe the WX16's ModBus slave database. Any portion of this data may be read by a ModBus master device such as a PC, PLC or DCS. Since the ModBus port is RS-485, many WX16s may be multi-dropped onto the same cable.

Memory Integer ASCII

Notes: ASCII may be read 2 characters at a time or in strings using a multiple register read.

Sixteen character channel tag name

Type	Channel	First	Last	Read FC	Write FC	Notes
Channel Tag	1	40401	40408	3	n/a	2 characters per register
Channel Tag	2	40409	40416	3	n/a	2 characters per register
Channel Tag	3	40417	40424	3	n/a	2 characters per register
Channel Tag	4	40425	40432	3	n/a	2 characters per register
Channel Tag	5	40433	40440	3	n/a	2 characters per register
Channel Tag	6	40441	40448	3	n/a	2 characters per register
Channel Tag	7	40449	40456	3	n/a	2 characters per register
Channel Tag	8	40457	40464	3	n/a	2 characters per register
Channel Tag	9	40465	40472	3	n/a	2 characters per register
Channel Tag	10	40473	40480	3	n/a	2 characters per register
Channel Tag	11	40481	40488	3	n/a	2 characters per register
Channel Tag	12	40489	40496	3	n/a	2 characters per register
Channel Tag	13	40497	40504	3	n/a	2 characters per register
Channel Tag	14	40505	40512	3	n/a	2 characters per register
Channel Tag	15	40513	40520	3	n/a	2 characters per register
Channel Tag	16	40521	40528	3	n/a	2 characters per register

Six character Eunits Tag

Type	Channel	First	Last	Read FC	Write FC	Notes
------	---------	-------	------	---------	----------	-------

EUNITS	1	40529	40531	3	n/a	2 characters per register; 3 registers per channel
EUNITS	2	40532	40534	3	n/a	2 characters per register; 3 registers per channel
EUNITS	3	40535	40537	3	n/a	2 characters per register; 3 registers per channel
EUNITS	4	40538	40540	3	n/a	2 characters per register; 3 registers per channel
EUNITS	5	40541	40543	3	n/a	2 characters per register; 3 registers per channel
EUNITS	6	40544	40546	3	n/a	2 characters per register; 3 registers per channel
EUNITS	7	40547	40549	3	n/a	2 characters per register; 3 registers per channel
EUNITS	8	40550	40552	3	n/a	2 characters per register; 3 registers per channel
EUNITS	9	40553	40555	3	n/a	2 characters per register; 3 registers per channel
EUNITS	10	40556	40558	3	n/a	2 characters per register; 3 registers per channel
EUNITS	11	40559	40561	3	n/a	2 characters per register; 3 registers per channel
EUNITS	12	40562	40564	3	n/a	2 characters per register; 3 registers per channel
EUNITS	13	40565	40567	3	n/a	2 characters per register; 3 registers per channel
EUNITS	14	40568	40570	3	n/a	2 characters per register; 3 registers per channel
EUNITS	15	40571	40573	3	n/a	2 characters per register; 3 registers per channel
EUNITS	16	40574	40576	3	n/a	2 characters per register; 3 registers per channel

Six character Value ASCII string

Type	Channel	First	Last	Read FC	Write FC	Notes
ASCII Value	1	40577	40579	3	n/a	2 characters per register; 3 registers per channel
ASCII Value	2	40580	40582	3	n/a	2 characters per register 3 registers per channel
ASCII Value	3	40583	40585	3	n/a	2 characters per register 3 registers per channel
ASCII Value	4	40586	40588	3	n/a	2 characters per register 3 registers per channel
ASCII Value	5	40589	40591	3	n/a	2 characters per register 3 registers per channel
ASCII Value	6	40592	40594	3	n/a	2 characters per register 3 registers per channel
ASCII Value	7	40595	40597	3	n/a	2 characters per register 3 registers per channel
ASCII Value	8	40598	40600	3	n/a	2 characters per register 3 registers per channel
ASCII Value	9	40601	40603	3	n/a	2 characters per register; 3 registers per channel
ASCII Value	10	40604	40606	3	n/a	2 characters per register 3 registers per channel
ASCII Value	11	40607	40609	3	n/a	2 characters per register 3 registers per channel
ASCII Value	12	40610	40612	3	n/a	2 characters per register 3 registers per channel
ASCII Value	13	40613	40615	3	n/a	2 characters per register 3 registers per channel
ASCII Value	14	40616	40618	3	n/a	2 characters per register 3 registers per channel
ASCII Value	15	40619	40621	3	n/a	2 characters per register 3 registers per channel
ASCII Value	16	40622	40624	3	n/a	2 characters per register 3 registers per channel

Memory Floating Point

Notes: Returned as 15 bit 2s complement with $\pm 5\%$ over/under range applied. Therefore, this must be considered when scaling values to be displayed at the ModBus master. The following equation may be used to determine a value for display.

$$\text{Display Value} = \frac{\text{MODBUS Value} \cdot (\text{Span Value} - \text{Zero Value}) \cdot 1.1}{32767} + (\text{Zero Value} - [(\text{Span Value} - \text{Zero Value}) \cdot 0.05])$$

Type	Channel	First	Last	Read FC	Write FC	Notes
Channel Value	1-16	33001-16	n/a	4	n/a	15bit 2s complement w/ $\pm 5\%$ over/under range

Analog Output

Notes: 12 bit integer for Channel Reading value = 800 counts = zero value, 4000 counts = 100% value.

Type	Channel	First	Last	Read FC	Write FC	Notes
Channel Reading	1-16	31001	31016	4	n/a	12bit integer

Channel Status words contain configuration and status bits for a channel. They are as follows:

Type	Channel	First	Last	Read FC	Write FC	Notes
Channel Status	1-16	31017	31032	4	n/a	16bit integer (see bit by bit definition below)
Alarm 1 Trip		bit0		1 = Low		0 = High
Alarm 1 Horn Drive		bit1		1 = On		0 = Off
Alarm 3 Type		bit2		1 = Level		0 = Fault
Alarm 2 Horn Drive		bit3		1 = On		0 = Off
Linearize		bit4		1 = On		0 = Off
Alarm 3 Trip		bit5		1 = Low		0 = High
Input Marker		bit6		1 = Input Marker Detected		0 = Normal Mode
Channel Disable		bit7		1 = Disabled		0 = Enabled
Controller Channel In Cal		bit8		1 = Local Cal Mode		0 = Normal Mode
ModBus Data Type		bit9		1 = 4 byte float		0 = 2 byte integer
reserved		bit10		reserved		reserved
reserved		bit11		reserved		reserved
Alarm 1 Latch		bit12		1 = Latching		0 = Non latching
Alarm 2 Latch		bit13		1 = Latching		0 = Non latching
Alarm 3 Latch		bit14		1 = Latching		0 = Non latching
Alarm 2 Trip		bit15		1 = Low		0 = High

Alarm status words are bits packed into 16 bit integer where lsb = channel 1 alarm status and msb = channel 16 alarm status.

Alarm status (bit = 1 indicates alarm is active)

Type	Channel	First	Last	Read FC	Write FC	Notes
Alarm 1 Status	1-16	31033	n/a	4	n/a	packed 16bit integer

Alarm 2 Status	1-16	31034	n/a	4	n/a	packed 16bit integer
Alarm 3 Status	1-16	31035	n/a	4	n/a	packed 16bit integer
*Relay Status	n/a	31036	n/a	4	n/a	packed 16bit integer

*Note: Common Relay status bits (register 31036) are as follows.

Relay 1= bit0.

Relay 2= bit1

Fault Relay = bit2

Horn Relay = bit3

Type	Channel	First	Last	Read FC	Write FC	Notes
Cal Status	1-16	31037	n/a	4	n/a	packed 16bit integer
Trend Interval Timer	1-16	31038	n/a	4	n/a	16bit integer (Time in Seconds)
Fault Status	1-16	31039	n/a	4	n/a	packed 16bit integer

Alarm LED flashing status

(bit = 1 indicates LED is flashing; "Acknowledge" clears all to 0):

Type	Channel	First	Last	Read FC	Write FC	Notes
Alarm 1 Status	1-16	31049	n/a	4	n/a	packed 16bit integer
Alarm 2 Status	1-16	31050	n/a	4	n/a	packed 16bit integer
Alarm 3 Status	1-16	31051	n/a	4	n/a	packed 16bit integer
Common LED Status	1-16	31052	n/a	4	n/a	packed 16bit integer

LCD Display Screen Displayed Integer

Type	Channel	First	Last	Read FC	Write FC	Notes
LCD Screen	n/a	31053	n/a	4	n/a	8bit integer

Sensor Life

Type	Channel	First	Last	Read FC	Write FC	Notes
Sensor Life	1	31065	n/a	4	n/a	Signed 16bit integer
Sensor Life	2	31066	n/a	4	n/a	Signed 16bit integer
Sensor Life	3	31067	n/a	4	n/a	Signed 16bit integer
Sensor Life	4	31068	n/a	4	n/a	Signed 16bit integer
Sensor Life	5	31069	n/a	4	n/a	Signed 16bit integer
Sensor Life	6	31070	n/a	4	n/a	Signed 16bit integer
Sensor Life	7	31071	n/a	4	n/a	Signed 16bit integer
Sensor Life	8	31072	n/a	4	n/a	Signed 16bit integer
Sensor Life	9	31073	n/a	4	n/a	Signed 16bit integer
Sensor Life	10	31074	n/a	4	n/a	Signed 16bit integer
Sensor Life	11	31075	n/a	4	n/a	Signed 16bit integer
Sensor Life	12	31076	n/a	4	n/a	Signed 16bit integer
Sensor Life	13	31077	n/a	4	n/a	Signed 16bit integer
Sensor Life	14	31078	n/a	4	n/a	Signed 16bit integer
Sensor Life	15	31079	n/a	4	n/a	Signed 16bit integer
Sensor Life	16	31080	n/a	4	n/a	Signed 16bit integer

*Note: -2 = Disabled, -1 = CAL Required, 0-100 = Sensor Life

Coils

Notes: Set this coil to issue an alarm "Acknowledge" via ModBus (see "Echo Ack" in section 2.3.4).

Type	Channel	First	Last	Read FC	Write FC	Notes
Alarm Reset	n/a	2001	n/a	n/a	5	write 0xff to high byte to set

Memory Discretes

Notes: May be read as single discrete or packed with multiple register read.

Type	Channel	First	Last	Read FC	Write FC	Notes
Chnl Alarm 1	1-16	12001-16	n/a	2	n/a	discrete, may be packed

Type	Channel	First	Last	Read FC	Write FC	Notes
Chnl Alarm 2	1-16	12017-32	n/a	2	n/a	discrete, may be packed

Type	Channel	First	Last	Read FC	Write FC	Notes
Chnl Alarm 3	1-16	12033-48	n/a	2	n/a	discrete, may be packed

Memory Reals

Notes: Real value represents float value without the decimal point such as 123.4 is returned as 1234. Decimal divisor is returned as 1, 10, 100, or 1000 for decimal position of 1, 2, 3, or 4, where 123.4 would return the value 10.

Type	Channel	First	Last	Read FC	Write FC	Notes
Zero Real	1-16	41001-16	n/a	3	n/a	zero real w/o decimal point
Zero DP	1-16	41017-32	n/a	3	n/a	zero real divisor
Span Real	1-16	41033-48	n/a	3	n/a	span real w/o decimal point
Span DP	1-16	41049-64	n/a	3	n/a	span real divisor
Alarm 1 Real	1-16	41065-80	n/a	3	n/a	alarm 1 real w/o decimal point
Alarm 1 DP	1-16	41081-96	n/a	3	n/a	alarm 1 real divisor
Alarm 2 Real	1-16	41097-112	n/a	3	n/a	alarm 2 real w/o decimal point
Alarm 2 DP	1-16	41113-28	n/a	3	n/a	alarm 2 real divisor
Alarm 3 Real	1-16	41129-44	n/a	3	n/a	alarm 3 real w/o decimal point
Alarm 3 DP	1-16	41145-60	n/a	3	n/a	alarm 3 real divisor
Fault Real	1-16	41161-76	n/a	3	n/a	alarm 3 real w/o decimal point
Fault DP	1-16	41177-92	n/a	3	n/a	alarm 3 real divisor

24-Hour Trend Database

The 24 hour MAX, MIN and AVERAGE trend data may be retrieved over the ModBus serial interface. Each channel consists of 240 MAX, MIN and AVERAGE values, or, one value for every 1/10 hour (6 minutes). Since there are 16 channels this database equals 3,840 registers in addresses 33017-36857. Due to the large size, MAX, MIN or AVERAGE values may only be retrieved one at a time. To improve bandwidth, the master may retrieve the database in blocks of 120 registers at a time (one half of a channel's data). The C1 only updates these 3,840 registers upon receiving an update command from the ModBus master.

Type	Channel	First	Last	Read FC	Write FC	Notes
Update MIN	n/a	2065	n/a	n/a	5	Moves 24-hour MIN data trend to trend data base
Update AVG.	n/a	2066	n/a	n/a	5	Moves 24-hour MIN data trend to trend data base
Update MAX	n/a	2067	n/a	n/a	5	Moves 24-hour AVG data trend to trend data base

This update requires several seconds. Therefore, a data ready register is available to notify the master upon completion.

Type	Channel	First	Last	Read FC	Write FC	Notes
MIN Ready	n/a	12065	n/a	2	n/a	0 = data ready; 1 = update in progress
AVG. Ready	n/a	12066	n/a	2	n/a	0 = data ready; 1 = update in progress
MAX Ready	n/a	12067	n/a	2	n/a	0 = data ready; 1 = update in progress

Trend database registers

Type	Channel	First	Last	Read FC	Write FC	Notes
24-hr Trend	1-16	33017	36857	5	n/a	Transfers 24-hour trend for MAX, MIN or AVG.

SECTION - 6.

6.0 Panel / Rack Mount Enclosure

The WX16 shown in Figure 6.1 is a half-width 19" rack enclosure. It is supplied with hardware that allows mounting in either a full-width 19" rack style cabinet or it may be panel-mounted in a rectangular cutout. Only two 8-channel I/O option PCB's such as analog input or discrete relays may be mounted directly to the back of the enclosure. Additional 8-channel I/O option PCB's must be located external from the assembly on another mounting plate. A 3-foot length of I²C cable is also supplied for this purpose. Weight is approximately 7 pounds. Properly ground the enclosure and follow national and local electrical codes.

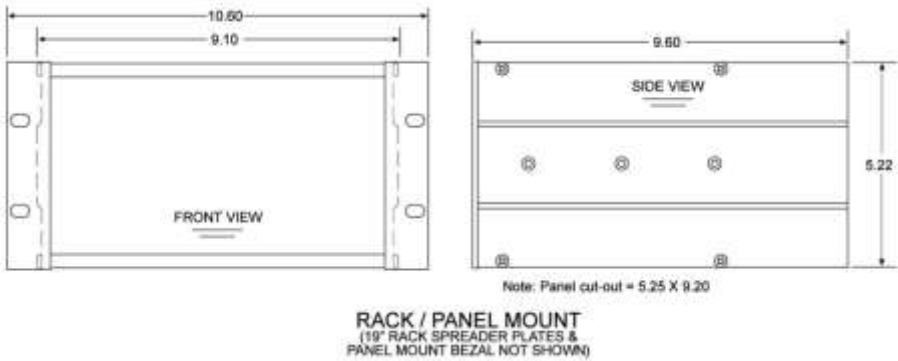
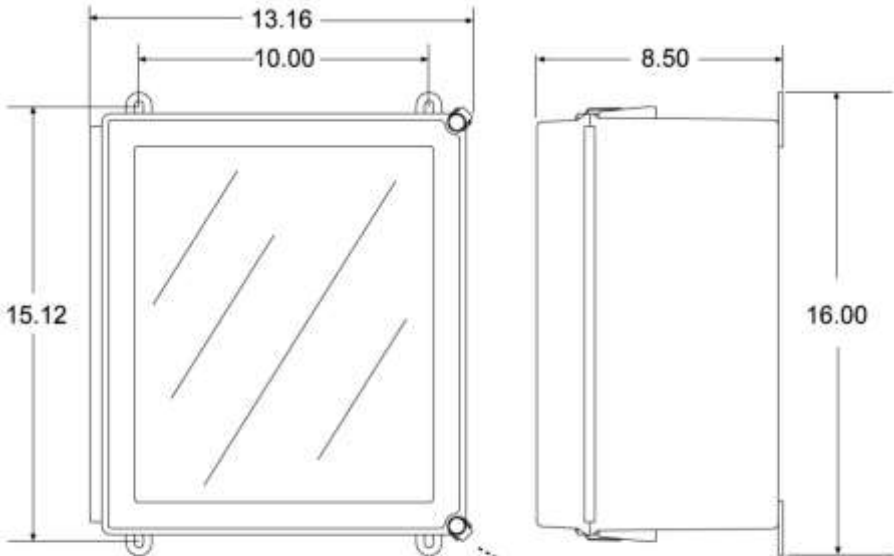

Figure 6.1

6.1 NEMA 4X Wall Mount Fiberglass Enclosure

The WX16 shown in Figure 6.2 is a fiberglass NEMA 4X wall mount enclosure. Seven 8-channel I/O option PCB's, such as analog input or discrete relays, may be mounted inside this enclosure. It is suitable for mounting outdoors, but an above-mounted weather deflector shield is recommended. Weight is approximately 17 pounds. Figure 6.3 provides important warning information concerning correct grounding procedures for non-metallic enclosures. Conduit entries are not provided so installers may place entries as needed. Bottom or lower side areas are recommended. Care must be taken to avoid drilling into circuit boards mounted inside the enclosure. Properly ground the enclosure and follow national and local electrical codes.



Note: 4 mounting holes are .31 diameter

SHOCK HAZARD

ADD LOCKING DEVICE TO CLASP ON BOTTOM RIGHT SIDE TO PREVENT CONTACT WITH DANGEROUS VOLTAGES. REMOVE AC POWER BEFORE SERVICING EQUIPMENT.



NEMA 4X WALL MOUNT

Figure 6.2



GROUNDING OF EQUIPMENT AND CONDUIT

Ground in accordance with the requirements of the National Electrical Code.

Conduit hubs for metallic conduit must have a grounding bushing attached to the hub on the inside of the enclosure. Grounding bushings have provisions for connection of a grounding wire. Non-metallic conduit and hubs require the use of a grounding wire in the conduit. Grounding bushings are not required. System grounding is provided by connection wires from all conduit entries to the subpanel or to other suitable point which provides continuity. Any device having a metal portion or portions extending out of the enclosure must also be properly grounded.

TYPICAL GROUNDING ILLUSTRATIONS

METALLIC CONDUIT

NON-METALLIC CONDUIT

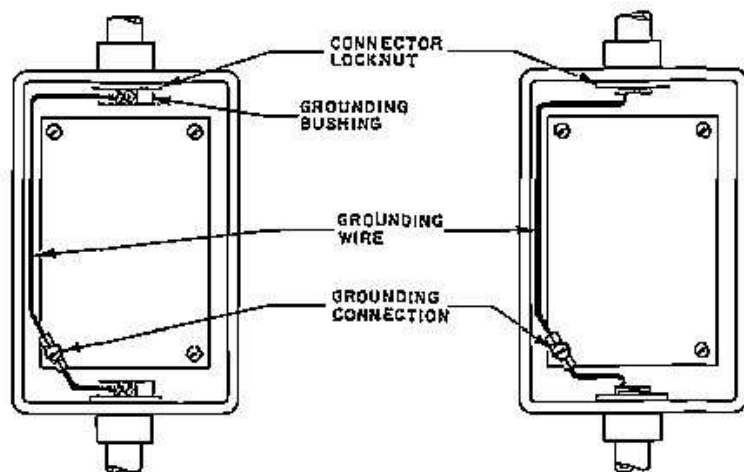
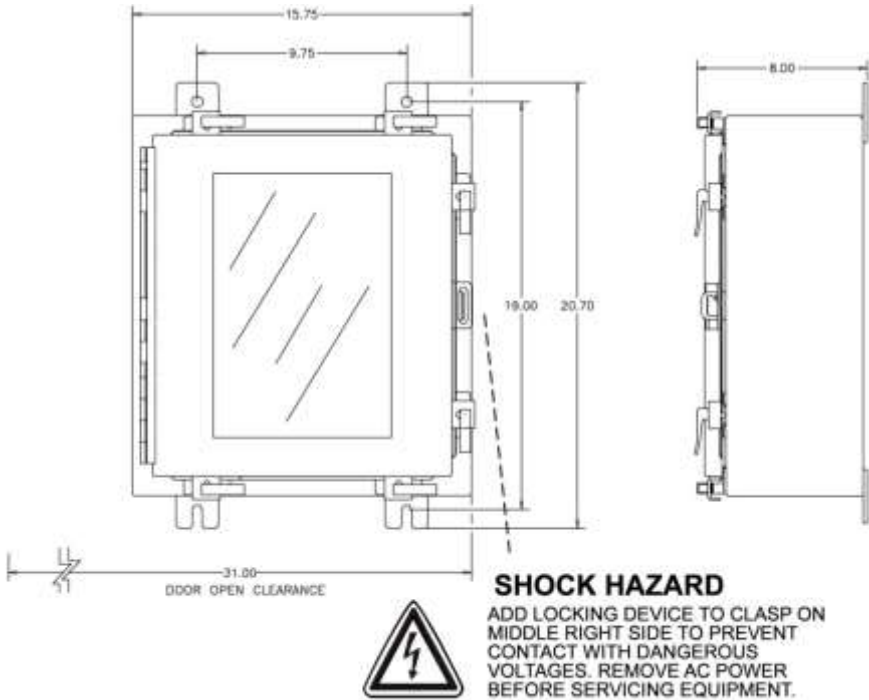

Figure 6.3

6.2 NEMA 4X Wall Mount 316 Stainless Steel Enclosure

The WX16 shown in Figure 6.4 is a 316 stainless steel NEMA 4X wall mount enclosure. Seven 8-channel I/O option PCB's, such as analog input or discrete relays, may be mounted inside this enclosure. It is suitable for mounting outdoors, but an above-mounted weather deflector shield is recommended. Weight is approximately 30 pounds. Conduit entries are not provided so installers may place entries as needed. Bottom or lower side areas are recommended. Care must be taken to avoid drilling into circuit boards mounted inside the enclosure. Properly ground the enclosure and follow national and local electrical codes.



316 STAINLESS-STEEL NEMA 4X WALL MOUNT

Figure 6.4

6.3 XP NEMA 7 Explosion-Proof Wall Mount Enclosure

The WX16XP shown in Figure 6.5 is an aluminum NEMA 4X / 7 wall mount enclosure designed for mounting into DIV 1&2 Groups B,C,D potentially hazardous areas. Eleven, 8 channel I/O option PCB's, such as analog inputs or discrete relays, may be mounted inside this enclosure. It is suitable for mounting outdoors, but an above-mounted weather deflector shield is recommended. Weight is approximately 110 pounds. Properly ground the enclosure and follow national and local electrical codes.

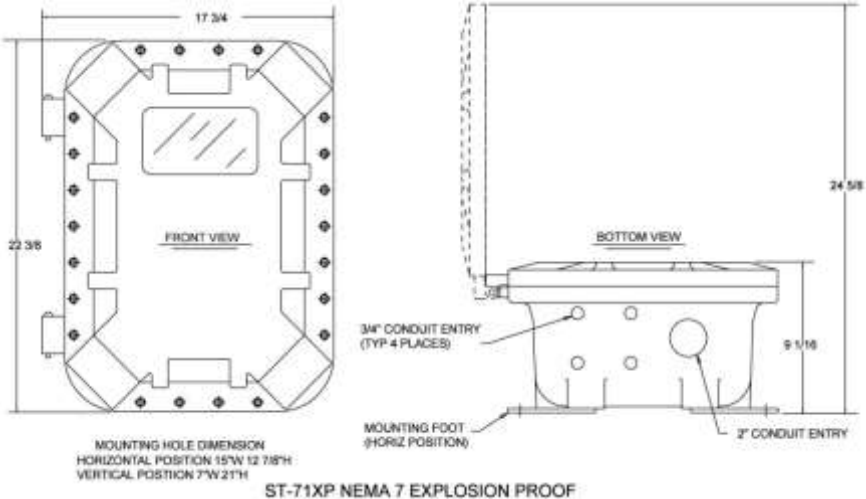

Figure 6.5

6.4 Main I/O & Option PCB Footprint Dimensions

WX16 controllers have virtually unlimited possibilities for configuration of options such as analog I/O, discrete relays, printer interface and others. All WX16 enclosure styles require the Main I/O PCB (Figure 3.1) but also support the mounting of additional option PCB's as described below:

- WX16PM Panel / Rack Mount supports 2 option positions as standard and 4 more with the 10-0180 expansion plate (since in panel / rack mount installations 10-0180's must be mounted in user space behind panels or inside racks, multiple 10-0180's may be incorporated to support the required option positions).

- WX16N4 & WX16SS NEMA 4X Wall Mount supports 3 option positions as standard and 4 more with the 10-0180 expansion plate. If more than 7 option positions are required, the 10-0178 NEMA 4X wall mount option enclosure supporting 8 positions may be added.
- WX16XP NEMA 7 Wall Mount supports 5 option positions as standard and 3 more with the 10-0181 expansion plate.

Figure 6.6 provides Main I/O and option PCB dimensions.

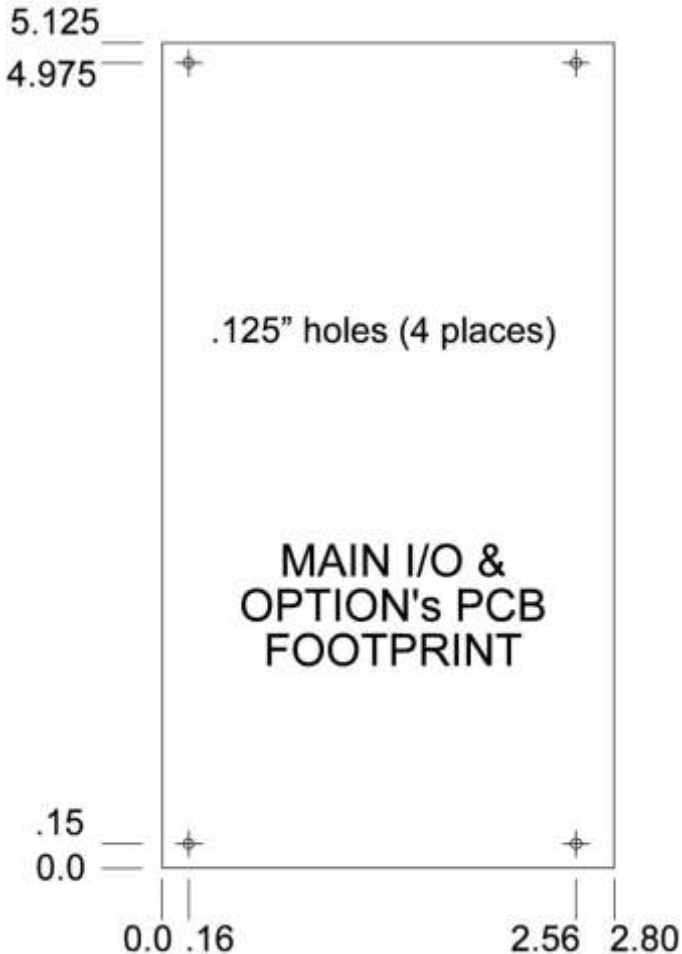

Figure 6.6

SECTION - 7.

7.0 Adding The “Wireless” Radio Kit Option

WX16 *master* / *slave* serial ports may be connected to a FHSS (Frequency Hopping Spread Spectrum) wireless radio modem shown in Figure 7.1. There are two different frequency options offered, 900 MHz and 2.4 GHz. 900 MHz is available in a single port modem (10-0364) or dual port modem (10-0365). 2.4 GHz is also available in a single port (10-0357) or dual port modem (10-0358). The dual port radio modems have two radio modules installed and can be used to receive and transmit data simultaneously. The radio kit options allow three separate modes of wireless operation. These are “Wireless Receiver” (section 7.2) accepting data from OLCT 200 sensor transmitters, “Wireless ModBus Slave” (section 7.3) providing data to a ModBus *master* (*master* side of network requires additional radio), and “Wireless ModBus Master” (section 7.4) accepting wireless data from ModBus *slaves* (*slaves* side of network requires additional radio). “Wireless Receiver” and “Wireless ModBus Master” modes require the radio be connected to the WX16’s RS-485 *master* port and “Wireless ModBus Slave” mode connects it to the RS-485 *slave* port (Figure 3.1). It is important to remember RADIO SETUP functions described in section 7.1 may only be performed with the radio connected to the *master* port.

Each transceiver on a wireless network must have its **RADIO SETUP** menus configured to share the same hopping channel (0-32) and System ID (0-255) to communicate. All WX-series wireless transceivers utilize a Server-Client network where Clients synchronize their hopping to the Server. The Server transmits a beacon at the beginning of every hop (50 times per second). Client transceivers listen for this beacon, and upon hearing it, will indicate **InRange** with the LED on the radio modem board and synchronize their hopping with the Server. Each network should consist of only one Server. There should never be two servers on the same RF Channel number in the same coverage area, as the interference between the two servers will severely hinder RF communications. The Server must be in a powered location (as opposed to a battery-powered OLCT 200 utilizing a “sleep” mode) and Servers typically should be centrally located since all Clients must receive the beacon in order to communicate.

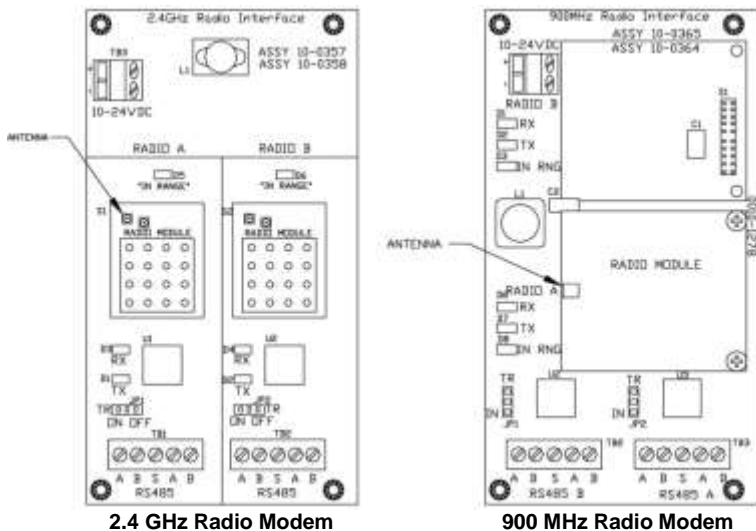

2.4 GHz Radio Modem

900 MHz Radio Modem

Note:
 10-0357 Has One Radio Module Installed
 10-0358 Has Two Radio Modules Installed

Note:
 10-0364 Has One Radio Module Installed
 10-0365 Has Two Radio Modules Installed

Figure 7.1

7.1 Radio Setup Menu

Radio modules must be connected to the WX16's *master* port for **RADIO SETUP**. Pressing the EDIT key with the arrow pointing to the **Radio Setup** menu brings the **RADIO CONFIG** menus to the screen (right side of Figure 7.2).

- **Hop Channel** may be set from 1-32 using the WX16 keypad and assigns the pseudo-random radio frequency hopping pattern. A transceiver will not go **InRange** of or communicate with a transceiver operating on a different Hop Channel.
- **System ID** may be set from 1-255 using the WX16 keypad and is similar to a password character or network number and makes network eavesdropping more difficult. A transceiver will not go in range of or communicate with a transceiver operating on a different System ID.
- **Mode** may be set for **CLIENT** or **SERVER**. For a single WX16 communicating to up to sixteen battery-powered OLCT 200 transceivers, Mode must = Server. To prolong battery life, OLCT 200's sleep most of the time and therefore may not be Servers. If an application calls for multiple WX16 locations, only one may be set for Server and all others must be Clients. This single Server transmits a beacon that all of the network's Clients synchronize to. **ONLY ONE SERVER PER NETWORK.**

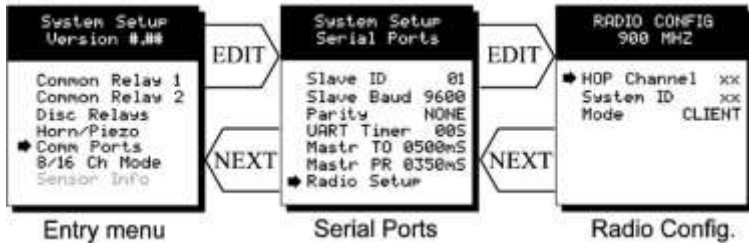

Figure 7.2

7.2 Wireless Receiver Mode

Wireless Receiver mode is exclusively for wireless communication to Oldham's OLCT 200 wireless sensor transmitters (See www.oldhamgas.com for more details). In Receiver mode, the radio connects to the WX16's *master* port and receives input data from up to sixteen OLCT 200 sensor transmitters. Wired and wireless inputs may be mixed between the WX16's sixteen channels, so it is possible to also accept wired signals from analog input option PCB's described in section 3.1.

Use the **WIRELESS RF900** setting shown at center of Figure 7.3 ONLY FOR COMMUNICATION TO OLCT 200 WIRELESS TRANSCIEVERS. See section 7.4 for setting up wireless networks with other ModBus slave devices.

OLCT 200's transmit 200 counts for 0% and 1000 counts for 100% full scale readings so **Input Min/Max** menu values should be 200 & 1000. The **Remote ID** menu entry must match the **Remote ID** address setting in the OLCT 200 providing data to this WX16 channel. **Input Req** is typically set to VALUE but also allows a BATT entry into this field. Entering BATT causes the channel to display (and alarm) from battery voltage levels at this OLCT 200. Voltage level of the 3.6 volt lithium battery in this OLCT 200 is also displayed on this screen.

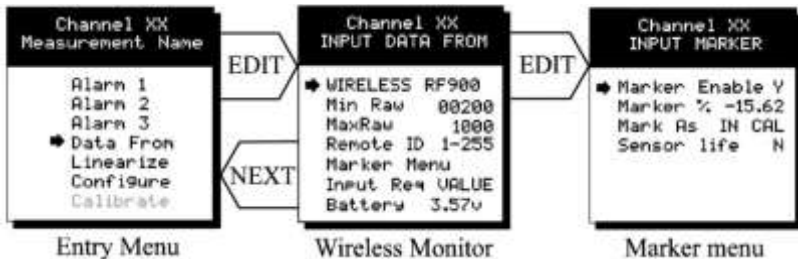

Figure 7.3

7.2.1 Radio Status Alarms - Wireless Receiver Mode

When an WX16 channel's **INPUT DATA FROM** menu is set for **WIRELESS RF900**, in addition to processing the OLCT 200's 10-bit "counts" value, it also receives status bits indicating **Communications Error**, **Low Battery** and **Calibration**.

- **Communications Error** – Each channel’s 30-minute trend screens (Figure 7.4) are very useful for diagnosing wireless problems, since they indicate amount of time since the most recent transmission was received. The down arrow on top of the trend screen resets to far right each time a transmission is received by that channel. When not in alarm, OLCT 200’s transmit each 5 minutes, so the arrow should never progress past the 5-minute interval. The WX16 activates the channel’s FAULT alarm and indicates ComErr if no transmission has been received in 18 consecutive minutes.
- **Low Battery** status indicates the OLCT 200’s integral 3.6V lithium D cell (part #10-0293) has dropped to below 3.3V and should be replaced very soon. LoBatt is indicated on the WX16’s LCD readout and the Alarm 3 LED flashes. Relays are not energized by low battery conditions. The actual battery voltage of each OLCT 200 may be seen in the **INPUT DATA FROM** screen described above in section 7.2.
- **Calibrations** performed at the OLCT 200 force a transmission of 75 counts (negative 15.62%) which may be indicated on the WX16’s LCD readout by In Cal by using the “Marker Menu” described in section 2.2.4b. Alarms are inhibited while the “Marker Value” of -15.62% is activated.

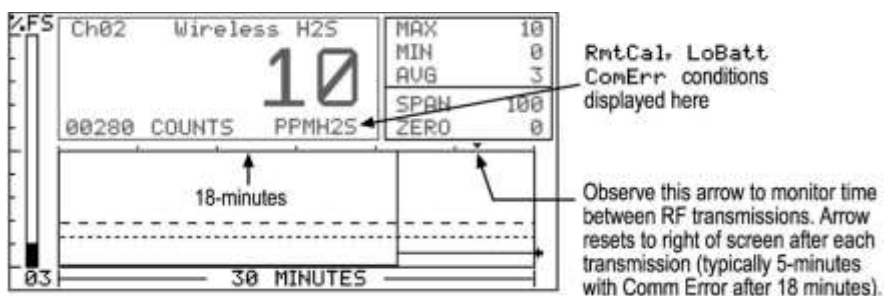

Figure 7.4

7.3 Wireless ModBus Slave Mode

Wireless MODBUS allows one or many WX16s to function as wireless ModBus *slaves* by connecting their RS-485 ModBus *slave* ports to a radio modem. These wireless networks require a ModBus *master* such as a DCS, HMI or another WX16 Sixteen Channel Controller; also equipped with a radio modem. As in all WX-series wireless networks, one transceiver must be designated as Server and all others as Clients. No special configuration is required by the *master* or *slave*, since this is a standard ModBus network. However, radios must have the same **Hop Channel** and **System ID** settings to communicate. Radio modules may only be configured when connected to the WX16’s *master* port. If it is necessary to modify **Hop Channel** and **System ID** settings, the radio module may be temporarily connected to the WX16’s master port for configuration then moved back to the *slave* port for operation.

The entire WX16 ModBus database, including registers and supported Function Codes, is documented in section 5.1.

7.4 Wireless ModBus Master Mode

WX16 applications as a “Wireless ModBus master” are similar to the “Wireless Receiver” mode described in section 7.2 and wiring to the radio modem is identical. The radio setup menus described in section 7.1 may also be used for configuring hop channel and system ID settings. The difference is each Channel’s **INPUT DATA FROM** menu must be configured with the correct **MODBUS** values to match the slave device instead of **Wireless RF900**. Wired and wireless inputs may be mixed between the WX16’s sixteen channels so it is also possible to accept wired signals from analog input option PCB’s described in section 3.1.

This is a popular application when the ModBus slave is another remote WX16 or Oldham’s WX4 controller available with built in radio modem compatible with the WX16 Radio Kit. Other ModBus slave devices may also be converted to wireless by addition of another Radio Kit at the slave’s location.

7.5 Antenna Selection

7.5.1 Dipole And Collinear Antennas

These antennas are connected to the radio via a length of coax cable. If the cable is larger than 6mm diameter (1/4 inch), do not connect the cable directly to the radio connection on the WX16 enclosure. Thick cables have large bending radii and sideways force on the connector can cause a poor connection. Use a short flexible pigtail (such as our 1000-2308) between the thick cable and the radio.

The polarity of these antennas is the same as the main axis, and they are normally installed vertically. They can be mounted horizontally (horizontal polarity), however the antenna at the other end of the wireless link would need to be mounted perfectly parallel for optimum performance. This is very difficult to achieve over distance. If the antenna is mounted vertically, it is only necessary to mount the other antennas vertically for optimum “coupling” – this is easy to achieve.

Dipole and collinear antennas provide best performance when installed with at least 1 to 2 “wavelengths” clearance of walls or steelwork. The wavelength is based on the frequency:

Wavelength in meters = 300 / frequency in MHz

Wavelength in feet = 1000 / frequency in MHz

Therefore, 900 MHz antennas require at least 2/3 meter (2 feet) and 2.4GHz 15 cm (6 inches). Antennas may be mounted with less clearance, but radiation will be reduced.

If the radio path is short, this won't matter. It is important the antenna mounting bracket be well connected to "earth" or "ground" for good lightning surge protection.

7.5.2 Yagi Antennas

Yagi antennas are directional along the central beam of the antenna. The folded element is toward the back, and the antenna should be "pointed" in the direction of the transmission. Yagis should also be mounted with at least 1 to 2 wavelengths of clearance from other objects. The polarity of the antenna is the same as the direction of the orthogonal elements. For example, if the elements are vertical, the Yagi transmits with vertical polarity.

In networks spread over wide areas, it is common for a central unit to have an omnidirectional antenna and the remote units to have Yagi antennas. In this case, as the omnidirectional antenna will be mounted with vertical polarity, then the Yagi's must also have vertical polarity. Care needs to be taken to ensure the Yagi is aligned correctly to achieve optimum performance.

Two Yagis can be used for a point-to-point link. In this case they can be mounted with the elements horizontally to give horizontal polarity. There is a large degree of RF isolation between horizontal and vertical polarity (approx -30dB), so this installation method is a good idea if there is a large amount of interference from another system close by transmitting vertical polarity.

An important mounting tip: If a Yagi has drainage holes in the dipole element, do not mount the antenna with the drainage.

7.5.3 Mounting Near Other Antennas

Avoid mounting your network's antenna near any other antenna even when the other antenna is transmitting on a different radio band. High RF energy of the transmission from a close antenna can "deafen" a receiver. This is a common cause of problems with wireless systems.

Because antennas are designed to transmit parallel to the ground rather than up or down, vertical separation between antennas is a lot more effective than horizontal separation. If mounting near another antenna cannot be avoided, mounting it beneath or above the other antenna is better than mounting beside it. Using different polarity to the other antenna (if possible) will also help to isolate the RF coupling.

7.5.4 Coax Cables

If a coax cable connects to the antenna via connectors, it is very important to weatherproof the connection using our 1000-2314 or equivalent sealing tape. Moisture ingress into a coax cable connection is the most common cause of problems with antenna installations. A three layer sealing process is recommended – an initial layer of electrical PVC tape, followed by a second layer of self-vulcanizing weatherproofing tape (1000-2314), with a final layer of electrical PVC tape.

Allowing a drip “U loop” of cable before the connection is also a good idea. The loop allows water to drip off the bottom of the U instead of into the connection, reduces installation strain and provides spare cable length in case later the original connectors need to be removed, the cable cut back and new connectors fitted.

Avoid installing coax cables together in long parallel paths. Leakage from one cable to another has a similar effect as mounting an antenna near another antenna.

7.6 Surge Protection & Grounding

Voltage surges can enter the WX16 via the antenna connection, power supply connection, connections to other equipment and even the “earth” or “ground” connection. Surges are electrical energy following a path to earth, and the best protection is achieved by “draining” the surge energy to earth via an alternate path. Wireless devices need to have a solid connection to earth via a ground stake or ground grid if the soil has poor conductivity. Solid connection means a large capacity conductor (not a small wire) with no coils or sharp bends. All other devices connected to the WX16 need to be grounded to the same ground point. There can be significant resistance between different ground points leading to very large voltage differences during lightning activity. As many wireless units are damaged by earth potential surges due to incorrect grounding as are damaged by direct surge voltage.

It is very difficult to protect against direct lightning strikes, but the probability of a direct strike at any one location is very small. Unfortunately, power line surges and electromagnetic energy in the air can induce high voltage surges from lightning activity several miles away.

7.6.1 Antenna Grounding

Electromagnetic energy in the air will be drained to ground via any and every earth path. An earth path exists between the antenna and the WX16, and to protect against damage, this earth path current must be kept as small as possible. This is achieved by providing better alternate earth paths. It is important to ground the antenna to the same ground point as the WX16. Antennas are normally mounted to a metal bracket that should be grounded to the WX16 earth connection. Surge energy induced into the antenna will be drained first by the mount’s ground connection, second by the outside shield of the coax cable to the ground connection on the radio and third by the internal conductor of the coax cable via the radio electronics. This third earth path causes damage unless the other two paths provide a better earth connection allowing surge energy to bypass the electronics.

When an antenna is located outside of a building and outside of an industrial plant environment, external coax surge diverters are recommended to further minimize the effect of surge current in the inner conductor of the coax cable.

Coax surge diverters have a gas-discharge element which breaks down in the presence of high surge voltage and diverts any current directly to a ground connection. A surge diverter is not normally required when the antenna is within a plant or factory environment, as the plant steelwork provides multiple parallel ground paths and good earthing will provide adequate protection without a surge diverter.

7.6.2 Connections to Other Equipment

Surges can enter the wireless unit from connected devices, via I/O, serial or Ethernet connections. Other data devices connected to the wireless unit should be well grounded to the same ground point as the wireless unit.

Special care needs to be taken where the connected data device is remote from the wireless unit requiring a long data cable. As the data device and the wireless unit cannot be connected to the same ground point, different earth potentials can exist during surge conditions.

There is also the possibility of surge voltages being induced on long lengths of wire from nearby power cables. Surge diverters can be fitted to the data cable to protect against surges entering the wireless unit.

The same principle applies when the I/O device is not close to the wireless unit, thus, the risk of surge increases. Surge diverters for I/O wiring are available to protect the wireless unit



EUROPEAN PLANT AND OFFICES

Z.I. Est – rue Orfila CS 20417 – 62027 Arras Cedex FRANCE
Tél: +33 (0)3 21 60 80 80 – Fax: +33 (0)3 21 60 80 00
Website: <http://www.oldhamgas.com>

AMERICAS
Tel: +1-713-559-9280
Fax: +1-281-292-2860
americas@oldhamgas.com

ASIA PACIFIC
Tel: +86-21-3127-6373
Fax: +86-21-3127-6365
sales@oldhamgas.com

EUROPE
Tel: +33-321-608-080
Fax: +33-321-608-000
info@oldhamgas.com