

BMOD0110 P016 B01
BMOD0250 P016 B01
BMOD0500 P016 B01
BMOD0500 P016 B02



FEATURES AND BENEFITS

- Ultra-low internal resistance
- Highest power performance available
- Lowest time constant
- 16.2 V operating voltage
- Over 1,000,000 duty cycles
- Individually balanced cells
- Voltage and temperature sensor output included
- Compact, rugged, fully enclosed splash proof design

APPLICATIONS

- Transportation
- Automotive
- Industrial
- Uninterruptible Power Supplies (UPS)
- Telecommunication

PRODUCT SPECIFICATIONS

CAPACITANCE	BMOD0110	BMOD0250	BMOD0500 B01	BMOD0500 B02
Nominal capacitance	110 F	250 F	500 F	500 F
Tolerance capacitance			+20%	
VOLTAGE				
Rated voltage			16.2 V DC	
Surge voltage			16.8 V DC	
Maximum operating voltage			750 V DC	
Isolation voltage ¹			2,500 V AC	
RESISTANCE				
ESR, DC ²	5.4 mΩ	4.1 mΩ	2.4 mΩ	2.4 mΩ
Resistance tolerance			Max.	
Thermal resistance (Rth)	1.1°C/W	0.91°C/W	0.5°C/W	0.5°C/W
TEMPERATURE				
Operating temperature range			-40°C to +65°C	
Storage temperature range			-40°C to +70°C	
Temperature characteristics				
Capacitance change			± 5% at 25°C (at -40°C)	
Internal resistance change			± 150% at 25°C (at -40°C)	
POWER				
Pd	2,300 W/kg	1,700 W/kg	2,700 W/kg	2,300 W/kg
Pmax	6,000 W/kg	4,400 W/kg	6,700 W/kg	6,700 W/kg
ENERGY				
Emax	1.49 Wh/kg	2.05 Wh/kg	3.17 Wh/kg	3.17 Wh/kg
LIFESPAN				
Endurance	After 1,500 hours application of rated voltage at 65°C. Within % of initial specified value.			
Capacitance change			<20% decrease	
Internal resistance change			<60% increase	
Shelf life	After 1,500 hours storage at 65°C without load shall meet specification for endurance.			

BMOD0110 P016 B01
BMOD0250 P016 B01
BMOD0500 P016 B01
BMOD0500 P016 B02



Life test

After 10 years at rated voltage and 25°C. Within % of initial specified value.

Capacitance change 30% decrease

Internal resistance 150% increase

CYCLES

Cycle test

Capacitors cycled between specified voltage and half rated voltage under constant current at 25°C (1,000,000).

Capacitance change 30% decrease
Within % of initial specified value.

Internal resistance 150% increase
Within % of initial specified value.

CURRENT	BMOD0110	BMOD0250	BMOD0500 B01	BMOD0500 B02
Leakage current ³	1.5 mA	3.0 mA	5.2 mA	150 mA
Short circuit current (Isc) ⁴	3,500 A	3,900 A	4,800 A	4,800 A
Maximum continuous current	30 A	115 A	150 A	150 A
Maximum peak current, 1 sec		2,000 A	4,000 A	4,000 A

CONNECTION

Terminal Screw

MONITORING (IN-BUILT)

Balancing⁵ VMS VMS VMS Passive

Thermal monitoring NTC

SIZE

Dimensions (L x W x H) (mm) (±0.5mm) See drawings

Weight 2.7 kg 4.45 kg 5.75 kg 5.75 kg

RATINGS

Humidity resistance IP65

Vibration resistance N/A SAE J2380 SAE J2380 SAE J2380

¹ 50Hz, 1 min. Maximum string operating voltage 1,500 V DC.

² Max., room temperature.

³ After 72 hours at 25°C. Initial leakage current can be higher.

⁴ **CAUTION:** C current possible with short circuit from UR. Do not use as an operating current.

⁵ VMS = Maxwell Technologies Voltage Management System.

MOUNTING RECOMMENDATIONS

BMOD0110 modules can be secured at 4 locations at provided holes for M6 bolts. Follow user manual instructions for terminal, balance and output connections.

BMOD0250 and **BMOD0500** modules can be secured at 8 locations, 4 front face and/or 4 bottom face, at provided holes for M6 bolts. Follow user manual instructions for terminal, balance and output connections.

MARKINGS

Modules are marked with the following information: Rated capacitance, rated voltage, product number, name of manufacturer, positive and negative terminal, warning marking, serial number.

BMOD0110 P016 B01
BMOD0250 P016 B01
BMOD0500 P016 B01
BMOD0500 P016 B02

DIMENSIONS (mm)

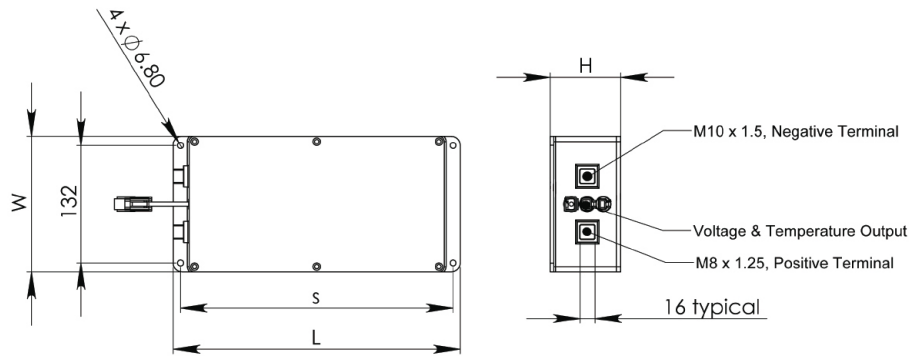

Part number	L (±0.25mm)	W (±0.25mm)	H (±0.5mm)	s (±0.5mm)
BMOD0110 P016 B01	260.1	154.9	79.3	240.0

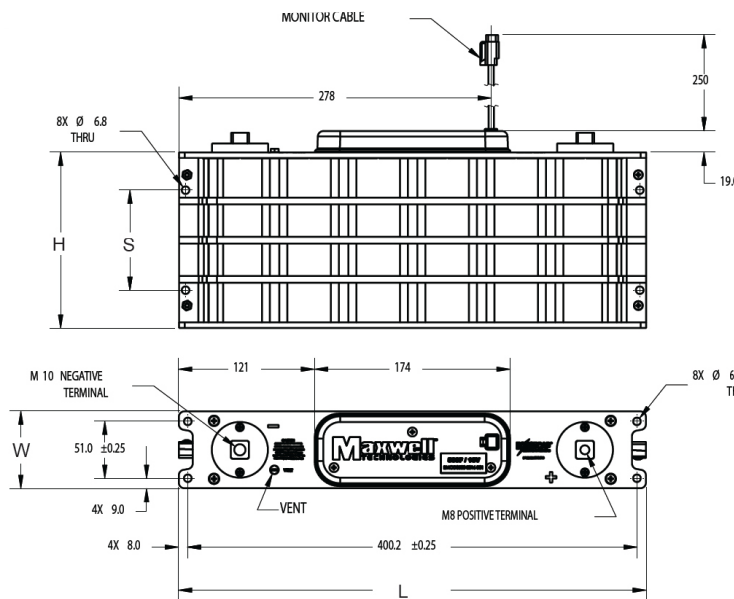

Part number	L (±0.25mm)	W (±0.25mm)	H (±0.5mm)	s (±0.5mm)
BMOD0250 P016 B01	416.2	67.2	103.2	53.7
BMOD0500 P016 B01	416.2	67.2	156.7	89.3
BMOD0500 P016 B02	416.2	67.2	156.7	89.3

Product dimensions are for reference only unless otherwise identified. Product dimensions and specifications may change without notice. Please contact Maxwell Technologies directly for any technical specifications critical to application.

Maxwell Technologies, Inc.
Worldwide Headquarters
 9244 Balboa Avenue
 San Diego, CA 92123
 USA
 Tel: +1 858 503 3300
 US Free Call: +1 877 511 4324
 Fax: +1 858 503 3301

Maxwell Technologies SA
 CH-1728 Rossens
 Switzerland
 Tel: +41 (0)26 411 85 00
 Fax: +41 (0)26 411 85 05

Maxwell Technologies, GmbH
 Brucker Strasse 21
 D-82205 Gilching
 Germany
 T: +49 (0)8105 24 16 10
 F: +49 (0)8105 24 16 19

Maxwell Technologies, Inc.
Shanghai Representative Office
 Rm.2104, Suncome Liauw's Plaza
 738 Shang Cheng Road, Pudong New Area
 Shanghai 200120, P.R. China
 Tel: +86 21 5836 5733
 Fax: +86 21 5836 5620

Online: www.maxwell.com • Email: info@maxwell.com