

NuPRO-595 Series
Half Size Socket7 ISA Bus Low Power Pentium SBC
With VGA/LCD/Ethernet/WOL Interface
User's Guide



Recycled Paper

Copyright Notice

Manual Rev 1.60: July 27, 2001

Part No:50-13011-201

This publication is protected by copyright and all rights are reserved. No part of it may be reproduced or transmitted by any means or in any form, without prior consent of the original manufacturer.

The information in this document has been carefully checked and is believed to be accurate. However, the original manufacturer assumes no responsibility for any inaccuracies that may appear in this manual. In no event will the original manufacturer be liable for direct, indirect, special, exemplary, incidental, incidental or consequential damages resulting from any defect or omission in this manual, even if advised of possibility of such damages. The material contained herein is for informational purposes only.

Acknowledgments

Award is a registered trademark of Award Software International, Inc.

IBM and PS/2 are trademarks of International Business Machines Corporation.

C&T is a trademark of Chips and Technologies Inc.

Intel and Pentium are registered trademarks of Intel Corporation.

Microsoft Windows is a registered trademark of Microsoft Corporation.

All other product names or trademarks are properties of their respective owners.

Getting service from ADLINK

Customer Satisfaction is always the most important thing for ADLINK Tech Inc. If you need any help or service, please contact us and get it.

ADLINK Technology Inc.			
Web Site	http://www.adlink.com.tw		
Sales & Service	service@adlink.com.tw		
Technical Support	NuDAQ	nudaq@adlink.com.tw	
	NuDAM	nudam@adlink.com.tw	
	NuIPC	nuipc@adlink.com.tw	
	NuPRO	nupro@adlink.com.tw	
	Software	sw@adlink.com.tw	
	AMB	amb@adlink.com.tw	
TEL	+886-2-82265877	FAX	+886-2-82265717
Address	9F, No. 166, Jian Yi Road, Chungho City, Taipei, 235 Taiwan, R.O.C.		

Please inform or FAX us of your detailed information for a prompt, satisfactory and constant service.

Detailed Company Information			
Company/Organization			
Contact Person			
E-mail Address			
Address			
Country			
TEL		FAX	
Web Site			
Questions			
Product Model			
Environment to Use	<input type="checkbox"/> OS : _____ <input type="checkbox"/> Computer Brand : _____ <input type="checkbox"/> M/B : <input type="checkbox"/> CPU : _____ <input type="checkbox"/> Chipset : <input type="checkbox"/> BIOS : _____ <input type="checkbox"/> Video Card : _____ <input type="checkbox"/> Network Interface Card : _____ <input type="checkbox"/> Other : _____		
Challenge Description			
Suggestions for ADLink			

NuPRO-595 Series Comparison Table

Model	NuPRO-595	NuPRO-596
Processor	Intel Pentium AMD K6-2, K6-3 Cyrix MII	Intel Pentium AMD K6-2, K6-3 Cyrix MII
Processor Socket	Socket7	Socket7
Chipset	Intel 430TX	Intel 430TX
BIOS	Award	Award
L2 cache	512KB	512KB
Max. SDRAM	128MB	128MB
Memory Sockets	1 x DIMM	1 x DIMM
VGA CRT/LCD	C&T 69000	C&T 69000
Watchdog Timer	0~255 seconds or minutes	0~255 seconds or minutes
PC/104 Connector	NO	NO
Multi I/O Chip	Winbond83977EF	Winbond83977EF
Enhanced IDE	yes	yes
2S/1P	yes	yes
USB	yes	yes
Ethernet (10/100Mbps)	Intel 82559	NO
H/W Monitoring	Winbond W83781D	Winbond W83781D
Board Size	185mm x 122mm	185mm x 122mm

Table of Contents

Chapter 1 Introduction	1
1.1 Checklist.....	2
1.2 Description	2
1.3 Features	3
1.4 Specifications.....	4
1.5 Intelligence	7
Chapter 2 Installations	10
2.1 CPU Installation	11
2.2 Memory Installation	11
2.3 Jumpers on the NuPRO-595	11
2.4 Connectors on the NuPRO-595.....	18
2.5 Watchdog Timer Configuration.....	31
2.6 Disk On Chip Address	33
Chapter 3 BIOS Configuration	34
3.1 BIOS Introduction	34
3.2 BIOS Setup.....	35
Chapter 4 Intel PIIX Bus Master IDE Driver Installation	62
4.1 System Requirements	63
4.2 Installing the Software	64
Chapter 5 VGA Driver Installation	66
5.1 Installing the Drivers for Windows 95	67
5.2 Installing the Drivers for Windows 98	68
5.3 Installing the Drivers for Windows NT 4.0.....	69
Chapter 6 LAN Driver Installation Guide	70
6.1 Introduction.....	70
6.2 Features	71
6.3 Software Drivers Support	71
6.4 Running Diagnostics.....	72
Chapter 7 Hardware Doctor Utility	76
Product Warranty/Service	81

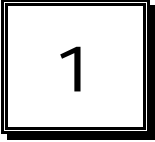

Introduction

This manual is designed to give you information on the NuPRO-595 CPU board.

The topics covered in this chapter are as follows:

- ◆ **Checklist**
- ◆ **Description**
- ◆ **Features**
- ◆ **Specifications**
- ◆ **Intelligence**
- ◆ **Layout of Key Components and Dimensions**

1.1 Checklist

Please check that your package is complete and contains the items below. If you discover damaged or missing items, please contact your dealer.

- The NuPRO-595 Industrial CPU Board
- This User's Manual
- 1 IDE Ribbon Cable
- 1 Floppy Ribbon Connector
- 2 Serial Port Ribbon Cable and 1 Parallel Port Attached to a Mounting Bracket
- 1 Optional 2-port
- 1 CD Containing Intel PCI IDE Driver, Flash Memory Utility, C&T 69000 VGA Driver, Intel 82559 LAN Driver and Hardware Monitor utility

1.2 Description

The NuPRO-595 is a Pentium Industrial CPU board based on the Intel 430TX chipset and is fully designed for harsh industrial environment. It features a Socket7 processor connector that is compatible with Intel Pentium MMX, AMD K6-2, K6-3 and Cyrix MI processors. This board accommodates up to 128MB SDRAM configuration.

The NuPRO-595 comes with Winbond's W83781D hardware monitoring device that monitors system and CPU temperature, system voltages, and CPU and chassis fan speeds to prevent system crashes by warning the user of adverse conditions. NuPro595 also has a case-open indicator for security.

1.3 Features

- CPU Speed 166~400MHz, Intel Pentium MMX & Low power Pentium &AMD K6-2,K6-3 &Cyrix MIII processors
- Bus Speed 66MHz
- Intel 430TX PCIset
- Up to 128MB SDRAM system memory
- C&T 69000 VGA chipset for LCD & CRT displays
- COM1 and COM2 serial ports configurable as RS232 and RS232/422/485 respectively
- Programmable watchdog timer, 0~255 second/minutes
- High speed bi-directional SPP/ECP/EPP parallel port
- Modem ring-on
- Hardware Monitoring
- 10/100 Mbps Ethernet interface (NuPRO-595 only)

1.4 Specifications

- ◆ **Processor Socket:** Socket7 connector
- ◆ **Processor:** Intel Pentium MMX, Low Power Pentium, AMD K6-2, K6-3 166~400MHz
- ◆ **Bus Speed:** 66MHz
- ◆ **Chipset:** Intel 82430TX, 82371EB
- ◆ **Secondary Cache:** 512KB
- ◆ **Memory Sockets:**
 - One 168-pin DIMM sockets
 - Max. 128MB SDRAM
 - Memory type: SDRAM (Synchronous DRAM)
- ◆ **BIOS:** Award BIOS, PnP support
 - FLASH EEPROM (256KB) for BIOS update
 - ISA Plug and Play (PnP) extension
 - Power management
 - Y2K Compliant
- ◆ **DMI BIOS Support:**

Desktop Management Interface (DMI) allows users to download system hardware-level information such as CPU type, CPU speed, internal/external frequencies and memory size.
- ◆ **Super I/O:** Winbond W83977EF
- ◆ **Parallel Port:**
 - One high-speed parallel port, SPP/EPP/ECP mode
 - ESD protection to 4KV
 - Downstream device protection to 30V

- ◆ **Serial Port:**
 - Two 16550 UART compatible ports with COM1 as RS232 and COM2 as selectable RS232/422/485
 - ESD protection to 2KV
- ◆ **Enhanced IDE: One Enhanced IDE interfaces for up to two devices, support PIO Mode 3/4 or Ultra DMA/33 IDE Hard Disk and ATAPI CD-ROM.,LS120,ZIP**
- ◆ **FDD Interface: One floppy drives (360KB, 720KB, 1.2MB, 1.44MB, 2.88MB)**
- ◆ **CRT/LCD: C&T 69000 chipset**
 - Embedded 2MB SDRAM display memory
 - Simultaneous CRT & LCD display
 - LCD panel supports DSTN/TFT
 - 1280x1024x8bpp colors CRT resolution
 - Up to 1280x1024x8bpp colors resolution for color active matrix TFT panels (12, 18, and 24bit analog) or (12+12), (18+18) double pixel/CLK interface
 - RAMDAC Latch-up protection
- ◆ **USB Interface:**
 - Two USB pin-header connectors, compliant with USB Specification Rev. 1.0
 - Individual over-current protection
- ◆ **DiskOnChip: The M-Systems flash disk supports system boot and storage capacity from 2MB to 144MB.**
- ◆ **Watchdog Timer: programmable**
 - Program I/O port 3F0H and 3F1H to configure watchdog timer
 - Time-out timing select 0~255 seconds/minutes
- ◆ **Green Function:** Power management via BIOS, activated through mouse/keyboard movement

- ◆ **PCI Bus Ethernet Interface: Intel 82559 chipset**
 - PCI local bus Ethernet controller
 - IEEE 802.3 10Base-T and 100Base-TX compatible physical longer support
 - IEEE802.3u auto-negotiation support for automatic speed selection
 - 10/100Mbps operation in a single port PCI bus master architecture
 - IEEE 802.3x (100Base-TX Flow control support)
 - Wake on Lan support
 - Management communication support to reduce the total cost of ownership (TCO)
- ◆ **Keyboard and Mouse Connectors:** PS/2 type mini-DIN that supports PC/AT; supports a 5-pin external keyboard connector
- ◆ **PICMG Compliance:** Fully compliant to PICMG standards
- ◆ **Power supply:** AT or ATX
- ◆ **Environmental and Mechanical:**
 - Power Consumption: +5V@11.8A (max), +12V@50mA , -12V
@30mA(while K6-3/400 CPU is installed)
 - Temperature: 0°C to 60°C
 - Humidity: 5% to 95%
 - Dimensions: 185mm x 129mm

1.5 Intelligence

- **System Health Monitoring:** A sensor for the CPU temperature on the NuPRO-595 monitors the CPU temperature, an external sensor for system temperature, case-open indicator, fan speed detection, system voltage monitoring
- **Windows 98 shut-off:** Allows shut-off control from within Windows 98 and through an ATX power supply.
- **Modem ring-on:** Allows system powering on through an external modem and through an ATX power supply.
- **Year 2000 Compliant BIOS:** The onboard Award BIOS is Year 2000 Compliant
- **Wake On LAN:** Through an ATX power supply and network connection, systems can be turned on from the power-off state.

Figure 1 Layout of key components:

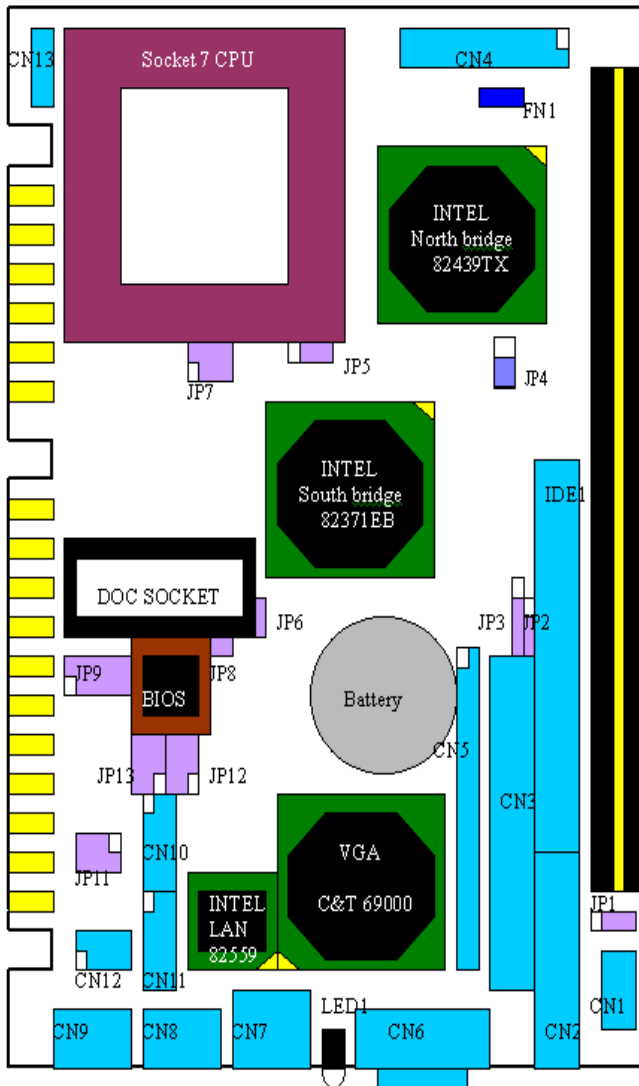
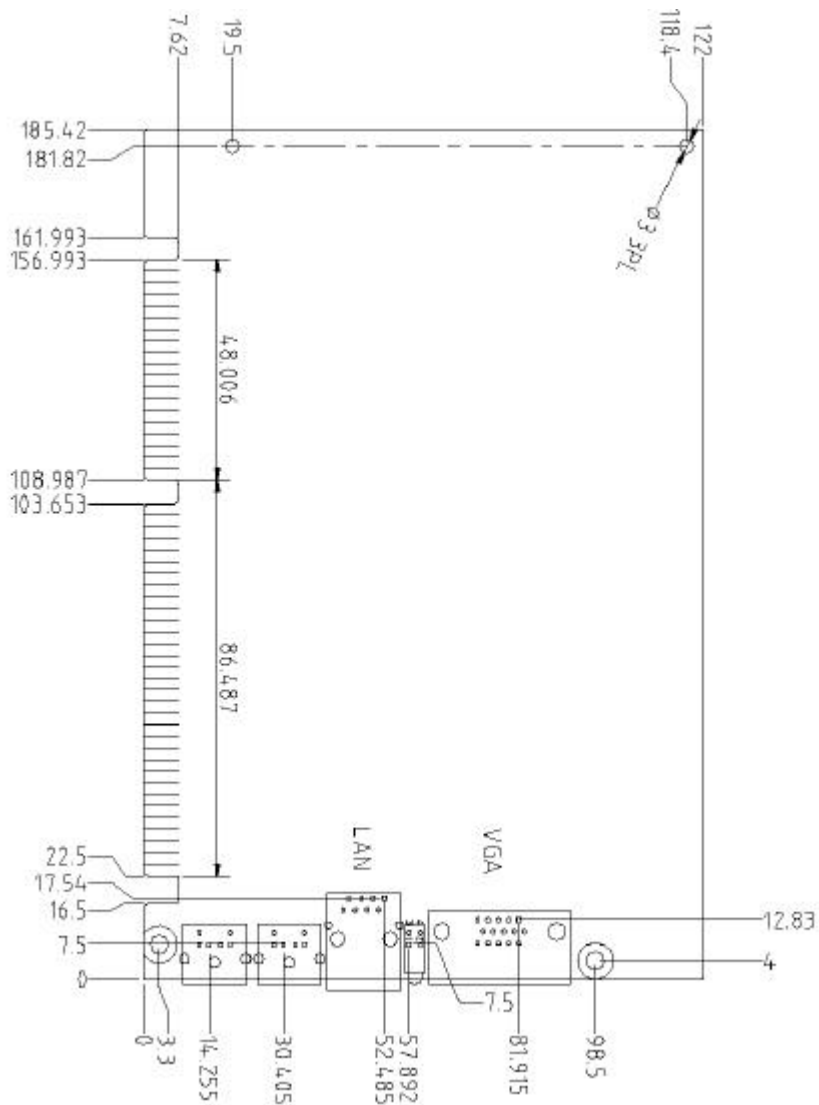

Figure 2 NuPRO-595 Mechanical Drawing



2

Installations

This chapter provides information on how to use the jumpers and connectors on the NuPRO-595 in order to set up a workable system. The topics covered are:

- ◆ **CPU Installation**
- ◆ **Memory Installation**
- ◆ **Jumpers on the NuPRO-595**
- ◆ **Connectors on the NuPRO-595**
- ◆ **Watchdog timer configuration**

2.1 CPU Installation

The NuPRO-595 Industrial CPU Board supports a Socket7 processor socket for Intel Pentium MMX, Low power Pentium, AMD K6-2/-3 and Cyrix MII processors.

The Socket7 connector comes with a lever to secure the processor. Before inserting the CPU, make sure the lever is raised perpendicular to the socket and the notch on the corner of the CPU corresponds with the notch on the inside of the socket.

After you have installed and lock the processor into place, check if the jumpers for the CPU type and speed are correct.

Note: Ensure that the CPU heat sink and the CPU top surface are in total contact to avoid CPU overheating problem that would cause your system to hang or be unstable.

2.2 Memory Installation

The NuPRO-595 Industrial CPU Board supports a 168-pin DIMM sockets for a maximum total memory of 128 SDRAMs. The memory modules can come in sizes of 16MB, 32MB, 64MB, 128MB SDRAM.

2.3 Jumpers on the NuPRO-595





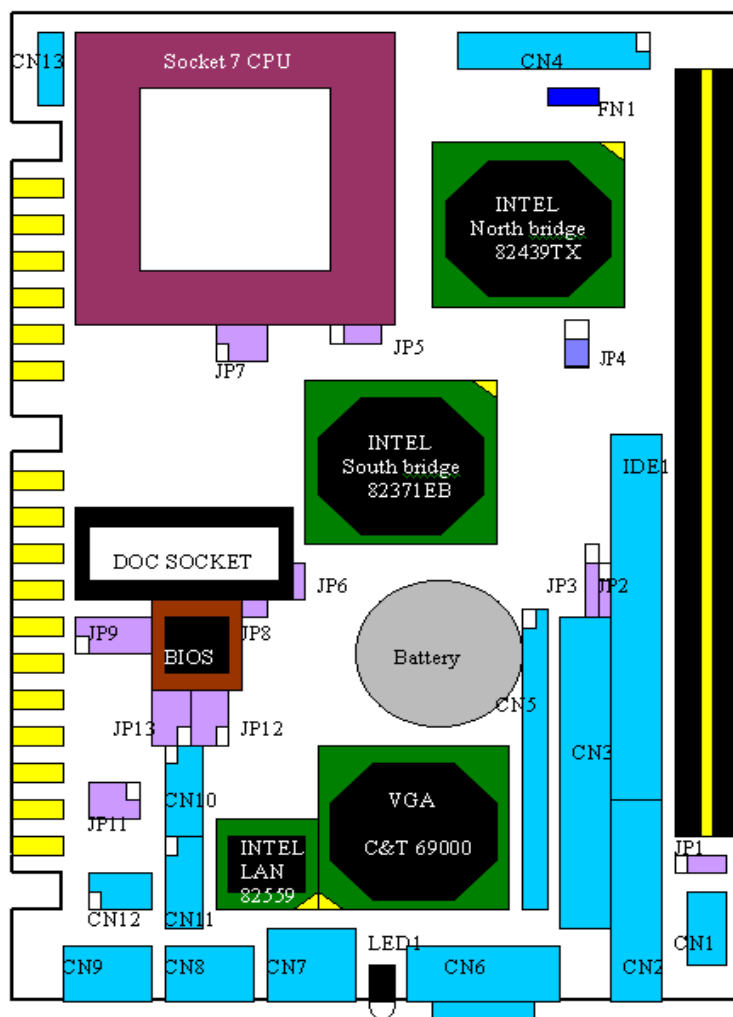















The jumpers on the NuPRO-595 allow you to configure your CPU board according to the needs of your applications. If you have doubts about the best jumper configuration for your needs, contact your dealer or sales representative. The following table lists the jumpers and dipswitches on NuPRO-595 and their respective functions.





















Figure3 Jumper Locations on the NuPRO-595















JP7: CPU Core Multiplier



The table below shows the correct setting to match the CPU frequency.

CPU Type	CPU Frequency	JP7
Intel Pentium CPU	2 x 66MHz 133MHz	ON  5 OFF  3 ON  1
	2.5x 66MHz 166MHz	ON  5 ON  3 ON  1
	3 x 66MHz 200MHz	OFF  5 ON  3 OFF  1
	3.5x 66MHz 233MHz	ON  5 OFF  3 OFF  1
AMD K6-2(K6-3)	2(6) x 66MHz 133(400)MHz	OFF  5 OFF  3 ON  1
	2.5 x 66MHz 166MHz	OFF  5 ON  3 ON  1
	3.0x 66MHz 200MHz	OFF  5 ON  3 OFF  1



CPU Type	CPU Frequency	JP7
AMD K6-2(K6-3)	3.5 x 66MHz 233MHz	OFF  5 OFF  3 OFF  1
	4.0 x 66MHz 266MHz	ON  5 OFF  3 ON  1
	4.5 x 66MHz 300MHz	ON  5 ON  3 ON  1
	5.0 x 66MHz 333MHz	ON  5 ON  3 OFF  1
	5.5 x 66MHz 366MHz	ON  5 OFF  3 OFF  1
Low Power Pentium	2.5 x 66MHz 166MHz	ON  5 ON  3 ON  1
	4.0 x 66MHz 266MHz	OFF  5 ON  3 ON  1

CPU Type	CPU Frequency	JP7
Cyrix MII	2 x 66MHz 133MHz	ON  5 OFF  3 ON  1
	2.5x 66MHz 166MHz	OFF  5 ON  3 ON  1
	3 x 66MHz 200MHz	OFF  5 ON  3 OFF  1
	3.5x 66MHz 233MHz	OFF  5 OFF  3 OFF  1





























































JP1 LCD Power Setting















3.3V Setting	5V Setting
	

JP2: Clear CMOS Content





JP2	Setting	Function
	Pin 2-3 Short/Closed	Normal operation
	Pin 1-2 Short/Closed	Clear CMOS Content

JP9 : CPU Core voltage









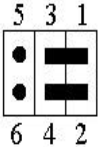
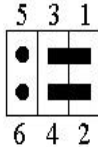

VCORE	JP9															
1.9V	<table border="0"> <tr> <td data-bbox="508 268 564 292">OFF</td> <td data-bbox="583 268 667 292"></td> <td data-bbox="680 268 697 292">9</td> </tr> <tr> <td data-bbox="508 304 564 328">ON</td> <td data-bbox="583 304 667 328"></td> <td data-bbox="680 304 697 328">7</td> </tr> <tr> <td data-bbox="508 341 564 365">ON</td> <td data-bbox="583 341 667 365"></td> <td data-bbox="680 341 697 365">5</td> </tr> <tr> <td data-bbox="508 378 564 402">ON</td> <td data-bbox="583 378 667 402"></td> <td data-bbox="680 378 697 402">3</td> </tr> <tr> <td data-bbox="508 414 564 438">OFF</td> <td data-bbox="583 414 667 438"></td> <td data-bbox="680 414 697 438">1</td> </tr> </table>	OFF		9	ON		7	ON		5	ON		3	OFF		1
OFF		9														
ON		7														
ON		5														
ON		3														
OFF		1														
2.0V	<table border="0"> <tr> <td data-bbox="499 504 564 528">OFF</td> <td data-bbox="583 504 667 528"></td> <td data-bbox="680 504 697 528">9</td> </tr> <tr> <td data-bbox="499 541 564 564">OFF</td> <td data-bbox="583 541 667 564"></td> <td data-bbox="680 541 697 564">7</td> </tr> <tr> <td data-bbox="499 577 564 601">OFF</td> <td data-bbox="583 577 667 601"></td> <td data-bbox="680 577 697 601">5</td> </tr> <tr> <td data-bbox="499 614 564 638">OFF</td> <td data-bbox="583 614 667 638"></td> <td data-bbox="680 614 697 638">3</td> </tr> <tr> <td data-bbox="499 651 564 675">OFF</td> <td data-bbox="583 651 667 675"></td> <td data-bbox="680 651 697 675">1</td> </tr> </table>	OFF		9	OFF		7	OFF		5	OFF		3	OFF		1
OFF		9														
OFF		7														
OFF		5														
OFF		3														
OFF		1														
2.1V	<table border="0"> <tr> <td data-bbox="508 754 564 778">ON</td> <td data-bbox="583 754 667 778"></td> <td data-bbox="680 754 697 778">9</td> </tr> <tr> <td data-bbox="499 791 564 815">OFF</td> <td data-bbox="583 791 667 815"></td> <td data-bbox="680 791 697 815">7</td> </tr> <tr> <td data-bbox="499 828 564 852">OFF</td> <td data-bbox="583 828 667 852"></td> <td data-bbox="680 828 697 852">5</td> </tr> <tr> <td data-bbox="499 865 564 888">OFF</td> <td data-bbox="583 865 667 888"></td> <td data-bbox="680 865 697 888">3</td> </tr> <tr> <td data-bbox="499 901 564 925">OFF</td> <td data-bbox="583 901 667 925"></td> <td data-bbox="680 901 697 925">1</td> </tr> </table>	ON		9	OFF		7	OFF		5	OFF		3	OFF		1
ON		9														
OFF		7														
OFF		5														
OFF		3														
OFF		1														
2.2V	<table border="0"> <tr> <td data-bbox="508 1005 564 1029">OFF</td> <td data-bbox="583 1005 667 1029"></td> <td data-bbox="680 1005 697 1029">9</td> </tr> <tr> <td data-bbox="508 1042 564 1066">OFF</td> <td data-bbox="583 1042 667 1066"></td> <td data-bbox="680 1042 697 1066">7</td> </tr> <tr> <td data-bbox="508 1078 564 1102">OFF</td> <td data-bbox="583 1078 667 1102"></td> <td data-bbox="680 1078 697 1102">5</td> </tr> <tr> <td data-bbox="508 1115 564 1139">OFF</td> <td data-bbox="583 1115 667 1139"></td> <td data-bbox="680 1115 697 1139">3</td> </tr> <tr> <td data-bbox="508 1152 564 1176">ON</td> <td data-bbox="583 1152 667 1176"></td> <td data-bbox="680 1152 697 1176">1</td> </tr> </table>	OFF		9	OFF		7	OFF		5	OFF		3	ON		1
OFF		9														
OFF		7														
OFF		5														
OFF		3														
ON		1														

VCORE	JP9
2.3V	ON  9 OFF  7 OFF  5 OFF  3 ON  1
2.4V	OFF  9 OFF  7 OFF  5 ON  3 OFF  1
2.8V	OFF  9 ON  7 OFF  5 OFF  3 OFF  1

JP4, JP5: CPU VI/O

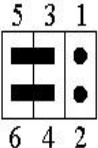
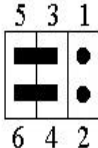
JP4	JP5	Voltage
		2.5V
		3.3V

JP11, JP12, JP13: COM2 OUTPUT MODE SETTING

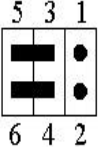
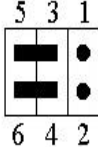
COM2 OUTPUT MODE	JP11	JP12	JP13
RS-232	ON  1 OFF  3 OFF  5		
RS-422	OFF  1 ON  3 OFF  5		
RS-485	OFF  1 OFF  3 ON  5		

2.4 Connectors on the NuPRO-595

The connectors on the NuPRO-595 allow you to connect external devices such as keyboard, floppy disk drives, hard disk drives, printers, etc. The following tables list the connectors on NuPRO-595 and their respective functions.

Figure 4 Connector Locations on the NuPRO-595

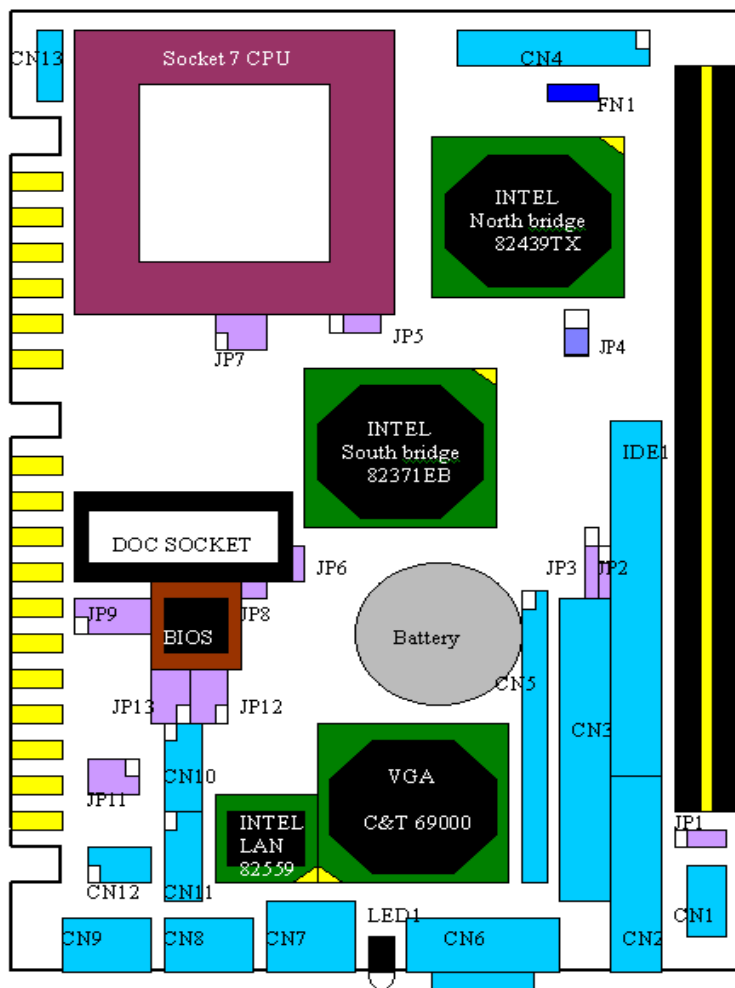

CN4: Miscellaneous Connector

The Miscellaneous connector is a 20-pin header that provides interfaces for the following functions.

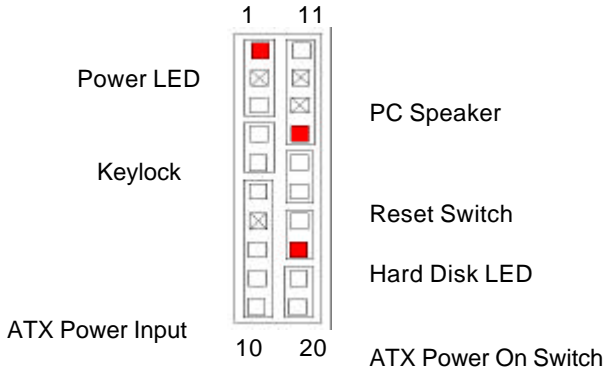

Speaker: Pins 11 - 14

This connector provides an interface to a speaker for audio tone generation. An 8-ohm speaker is recommended.

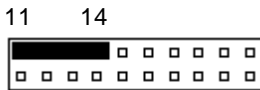

Pin #	Signal Name
11	Speaker out
12	No connect
13	No connect
14	+5V

Power LED and Keylock: Pins 11 - 15

The power LED indicates the status of the main power switch. The keylock switch, when closed, will disable the keyboard function.

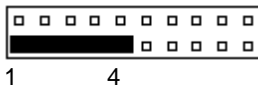

Pin #	Signal Name
1	+5V
2	No connect
3	Power LED#
4	Keylock#
5	Ground

ATX Power ON Switch: Pins 19 and 20

This 2-pin connector is an “ATX Power Supply On/Off Switch” on the system that connects to the power switch on the case. When pressed, the power switch will force the system to power on. When pressed again, it will force the system to power off.

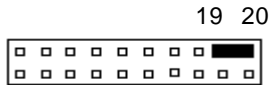

Reset Switch: Pins 15 and 16

The reset switch allows the user to reset the system without turning the main power switch off and then on again. Orientation is not required when making a connection to this header.

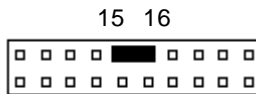

Hard Disk LED Connector: Pins 17 and 18

This connector connects to the hard drive activity LED on control panel. This LED will flash when the HDD is being accessed.

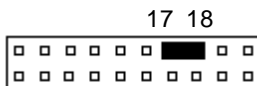

Pin #	Signal Name
17	HDD LED#
18	+5V

ATX Power Input: Pins 6-10

The power LED indicates the status of the main power switch. The keylock switch, when closed, will disable the keyboard function.

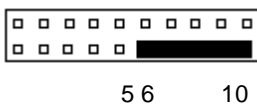

Pin #	Signal Name
6	Ground
7	No connect
8	Poweron#
9	+5VSB
10	+5VSB

CN1: External Keyboard Connector



Pin #	Signal Name
1	Keyboard clock
2	Keyboard data
3	NC
4	GND
5	Vcc

IDE1: EIDE Connectors

IDE1: Primary IDE Connector

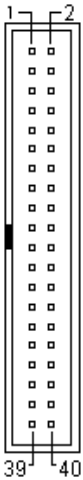

Signal Name	Pin #	Pin #	Signal Name
Reset IDE	1	2	Ground
Host data 7	3	4	Host data 8
Host data 6	5	6	Host data 9
Host data 5	7	8	Host data 10
Host data 4	9	10	Host data 11
Host data 3	11	12	Host data 12
Host data 2	13	14	Host data 13
Host data 1	15	16	Host data 14
Host data 0	17	18	Host data 15
Ground	19	20	
DRQ0	21	22	Ground
Host IOW	23	24	Ground
Host IOR	25	26	Ground
IOCHRDY	27	28	Host ALE
DACK0	29	30	Ground
IRQ14	31	32	No connect
Address 1	33	34	No connect
Address 0	35	36	Address 2
Chip select 0	37	38	Chip select 1
Activity	39	40	Ground

CN3: Floppy Drive Connector

CN3 is a 34-pin header and will support up to 2.88MB floppy drives.

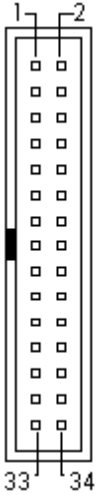

Signal Name	Pin #	Pin #	Signal Name
Ground	1	2	Drive density selection
Ground	3	4	No connect
Ground	5	6	Drive density selection
Ground	7	8	Index
Ground	9	10	Motor enable 0
Ground	11	12	Drive select 1
Ground	13	14	Drive select 0
Ground	15	16	Motor enable 1
Ground	17	18	Direction
Ground	19	20	Step
Ground	21	22	Write data
Ground	23	24	Write gate
Ground	25	26	Track 00
Ground	27	28	Write protect
Ground	29	30	Read data
Ground	31	32	Side 1 select
Ground	33	34	Diskette change

CN5: Flat Panel LCD Connector

CN5 is a 50-pin (dual in line header) for flat panel LCD displays. The following shows the pin assignments of this connector.



Signal Name	Pin #	Pin #	Signal Name
VCLK	1	2	P33
P34	3	4	P31
P35	5	6	P32
P30	7	8	P28
P29	9	10	P27
P25	11	12	P26
P24	13	14	P21
P23	15	16	P22
P16	17	18	P20
P17	19	20	P18
P19	21	22	P14
P13	23	24	P12
P15	25	26	P11
P7	27	28	PD10
5V 0R 3.3V	29	30	5V 0R 3.3V
P9	31	32	P8
P4	33	34	P6
P3	35	36	P5
P2	37	38	P1
MDE	39	40	P0
SHFCLK	41	42	ENABKL
FPVDD	43	44	FLM(V SYNC)
FPVEE	45	46	LP(H SYNC)
GND	47	48	GND
+12V	49	50	+12V

Flat Panel Display Interface Pin Descriptions

	Mono	Mono	Mono	Color	Color	Color	Color	Color	Color	Color	Color	Color
	SS	DD	DD	TFT	TFT	TFT	TFT	TFT+HF	STN-S	STN-S	STN-D	STN-D
Pin Name	8-bit	8-bit	16-bit	9/12/16 bit	18/24 bit	36-bit	18/24 bit	8-bit (4hP)	16-bit (4hP)	8-bit (4hP)	16-bit (4hP)	24-bit
P0	D0	UD3	UD7	B0	B0	FB0	FB0	R1	R1	UR1	UR0	UR0
P1	D1	UD2	UD6	B1	B1	FB1	FB1	B1	G1	UG1	UG0	UG0
P2	D2	UD1	UD5	B2	B2	FB2	FB2	G2	B1	UB1	UB0	UB0
P3	D3	UD0	UD4	B3	B3	FB3	FB3	B3	R2	UB2	UR1	LR0
P4	D4	LD3	UD3	B4	B4	FB4	SB0	G4	G3	LR1	LR0	LG0
P5	D5	LD2	UD2	G0	B5	FB5	SB1	R5	B2	LG1	LG0	LB0
P6	D6	LD1	UD1	G1	B6	SB0	SB2	B5	R3	LB1	LB0	UR1
P7	D7	LD0	UD0	G2	B7	SB1	B3		G3	LR2	LR1	UG1
P8			LD7	G3	G0	SB2	FG0		B3		UG1	UB1
P9			LD6	G4	G1	SB3	FG1		R4		UB1	LR1
P10			LD5	G5	G2	SB4	FG2		G4		UR2	LG1
P11			LD4	R0	G3	SB5	FG3		B4		UG2	LB1
P12			LD3	R1	G4	FG0	SG0		R5		LG1	UR2
P13			LD2	R2	G5	FG1	SG1		G5		LB1	UG2
P14			LD1	R3	G6	FG2	SG2		B5		LR2	UB2
P15			LD0	R4	G7	FG3	SG3		G6		LG2	LR2
P16					R0	FG4	FR0					LG2
P17					R1	FG5	FR1					LB2
P18					R2	SG0	FR2					UR3
P19					R3	SG1	FR3					UG3
P20					R4	SG2	SR0					LR3
P21					R5	SG3	SR1					LG3
P22					R6	SG4	SR2					LB3
P23					R7	SG5	SR3					
P24						FR0						
P25						FR1						
P26						FR2						
P27						FR3						
P28						FR4						
P29						FR5						
P30						SR0						
P31						SR1						
P32						SR2						
P33						SR3						
P34						SR4						

P35						SR5						
SHFCLK	SHFCLK	SHFCLK	SHFCLK	SHFCLK	SHFCLK	SHFCLK	SHFCLK	SHFCLK	SHFCLK	SHFCLK	SHFCLK	SHFCLK
Pixels/CIK:	8	8	16	1	1	2	2	2-2/3	5-1/3	2-2/3	5-1/3	8

CN2: Parallel Port Connector

The following table describes the pin out assignments of this connector.

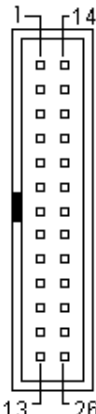

Signal Name	Pin #	Pin #	Signal Name
Line printer strobe	1	14	AutoFeed
PD0, parallel data 0	2	15	Error
PD1, parallel data 1	3	16	Initialize
PD2, parallel data 2	4	17	Select
PD3, parallel data 3	5	18	Ground
PD4, parallel data 4	6	19	Ground
PD5, parallel data 5	7	20	Ground
PD6, parallel data 6	8	21	Ground
PD7, parallel data 7	9	22	Ground
ACK, acknowledge	10	23	Ground
Busy	11	24	Ground
Paper empty	12	25	Ground
Select	13	N/A	N/A

CN11: COM1 Serial Port

CN11, a 10-pin header connector, is an onboard serial port of the NuPRO-590. The following table shows the pin assignments of this connector.

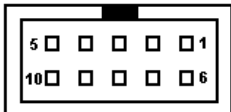

Pin #	Signal Name
1	DCD, Data carrier detect
2	RXD, Receive data
3	TXD, Transmit data
4	DTR, Data terminal ready
5	GND, ground
6	DSR, Data set ready
7	RTS, Request to send
8	CTS, Clear to send
9	RI, Ring indicator
10	NC

CN10: COM2 Serial Port

CN10, a 10-pin header connector, is the onboard COM2 serial port of the NuPRO-595. The following table shows its pin assignments.

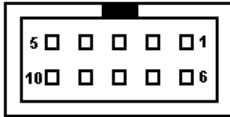

Pin #	Signal Name		
	RS-232	R2-422	RS-485
1	DCD	TX-	DATA-
2	RX	TX+	DATA+
3	TX	RX+	NC
4	DTR	RX-	NC
5	GND	GND	GND
6	DSR	RTS-	NC
7	RTS	RTS+	NC
8	CTS	CTS+	NC
9	RI	CTS-	NC
10	NC	NC	NC

CN9: PS/2 Keyboard Connector

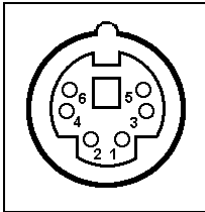

Pin #	Signal Name
1	Keyboard data
2	N.C.
3	GND
4	5V
5	Keyboard clock
6	N.C.

CN8: PS/2 Mouse Connector

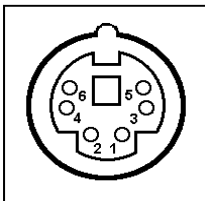

Pin #	Signal Name
1	Mouse data
2	N.C.
3	N.C.
4	5V
5	Mouse Clock
6	N.C.

CN6: VGA CRT Connector

The pin assignments of the CN6 VGA CRT connector are as follows:

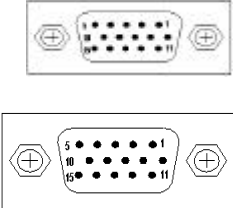

Signal Name	Pin	Pin	Signal Name
Red	1	2	Green
Blue	3	4	N.C.
GND	5	6	GND
GND	7	8	GND
N.C.	9	10	GND
N.C.	11	12	N.C.
HSYNC	13	14	VSYNC
NC	15		

CN7: RJ45 Connector

This connector is for the 10/100Mbps Ethernet capability of the CPU board. The figure below shows the pin out assignments of this connector and its corresponding input jack.

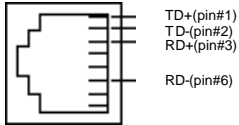

FN1: CPU Fan Power Connector

FN1 is a 3-pin header for the CPU fan. The fan must be a 12V fan.

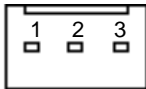

Pin #	Signal Name
1	Rotation
2	+12V
3	Ground

CN12: USB Connectors

The following table shows the pin outs of the USB connectors.

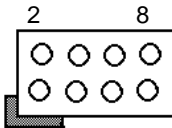

Pin #	Pin #	Signal Name
1	2	Vcc
3	4	USB0-,USB1-
5	6	USB0+, USB1+
7	8	Ground

CN13: Power Connectors

CN13 is a 4-pin header for power input connector



Pin #	Signal Name
1	+12V
2	Ground
3	Ground
4	+5V

LED1: LAN Activity Indicators

A and B are Green LED indicators located at the bracket side of the CPU board that shows LAN activity and the transfer rate in progress. Refer to the following table for the functions of each LED status.

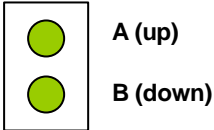

A(Speed status)	Function
OFF	10Mbps transfer rate
ON	100Mbps transfer rate

B(Link status)	Function
ON	Link
OFF	Link off
Blinking	Data transfer in Progress

JP8: Case open indicator

Connect a cable to case open sensor

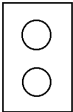

JP6: System temperature detection

Connect a cable to thermal sensor

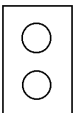

2.5 Watchdog Timer Configuration

The function of the watchdog timer is to reset the system automatically. It contains a one-second/minute resolution down counter, CRF2 of logical device 8, and two Watchdog control registers, WDT_CTRL0 and WDT_CTRL1 of logical device 8. We can use compatible PNP protocol to access configuration registers for setting up watchdog timer configuration.

To program configuration registers, the following configuration sequence must be followed:

1. Enter the extended function mode by writing 87h to the location 3F0h twice.
2. Configure the configuration registers
3. Exit the extended function mode by writing 0AAh to the location 3F0h.

The following example is written in Intel 8086 assembly language. It will reset the system in 15 seconds. We can use both keyboard interrupt and mouse interrupt to cause the watchdog to reload and start to count down from the value of CRF2.

```
MODEL SMALL
DATA
CODE
STARTUP
BEGIN:
```

```
;------
;Enter the extended function mode, interruptible double-write
;------
MOV DX,3F0H
MOV AL,87H
OUT DX,AL
OUT DX,AL
;------
;Configure logical device 7, configuration register CRE2
;------
MOV DX,3F0H
MOV AL,07H
OUT DX,AL ;point to logical Device Number Reg.
MOV DX,3F1H
MOV AL,07H ;select device 7
OUT DX,AL
```

```
MOV DX,3F0H
MOV AL,0E2H ;device 7, CRE2
OUT DX,AL
MOV DX,3F1H
MOV AL,0AH ;Watch Dog Timer Output
OUT DX,AL
```

```
MOV DX,3F0H
MOV AL,2AH ;CR2A
OUT DX,AL
MOV DX,3F1H
MOV AL,80H ;bit7=0 -> KBRST, bit7=1 -> GP12
OUT DX,AL
```

```
MOV DX,3F0H
MOV AL,07H
OUT DX,AL
MOV DX,3F1H
MOV AL,08H ;select device 8
OUT DX,AL
```

```
MOV DX,3F0H
MOV AL,0F3H ;device 8, CRF3
OUT DX,AL
MOV DX,3F1H
MOV AL,06H ;Watch Dog Timer is reset upon a
OUT DX,AL ;Mouse & Keyboard interrupt
```

```
MOV DX,3F0H
MOV AL,07H
OUT DX,AL
MOV DX,3F1H
MOV AL,08H
OUT DX,AL
```

```
MOV DX,3F0H
MOV AL,0F4H ;CRF4
OUT DX,AL
MOV DX,3F1H
MOV AL,40H ;bit6 =1 -> counter counts in seconds
OUT DX,AL ;bit6 =0 -> counter counts in minutes
```



```

MOV DX,3F0H
MOV AL,07H
OUT DX,AL
MOV DX,3F1H
MOV AL,08H
OUT DX,AL

MOV DX,3F0H
MOV AL,0F2H ;CRF2
OUT DX,AL
MOV DX,3F1H
MOV AL,0FH ;Time-out occurs after the value of CRF2
OUT DX,AL ;range 1~255, 00 -> disable Time-out
;-----
;Exit extended function mode
;-----
MOV DX,3F0H
MOV AL,0AAH
OUT DX,AL
EXIT
END

```

2.6 Disk On Chip Address

The NuPro-595/596 provides to install the Disk On Chip. The default Disk On Chip address is setting to D800-DFFF.

3

BIOS Configuration

This chapter describes the different settings available in the Award BIOS. The topics covered in this chapter are as follows:

3.1 BIOS Introduction

The Award BIOS (Basic Input/Output Subroutine) installed in your computer system's ROM supports Intel Pentium & AMD K6-2/3 processors. The BIOS provides critical low-level support for standard devices such as disk drives, serial ports, and parallel ports. It also adds virus and password protection as well as special support for detailed fine-tuning of the chipset controlling the entire system.

3.2 BIOS Setup

The Award BIOS provides a Setup utility program for specifying the system configurations and settings. The BIOS ROM of the system stores the Setup utility. When you turn on the computer, the Award BIOS is immediately activated. Pressing the key immediately allows you to enter the Setup utility. If you are a little bit late pressing the key, POST (Power On Self Test) will continue with its test routines, thus preventing you from invoking the Setup. If you still wish to enter Setup, restart the system by pressing the "Rest" button or simultaneously pressing the <Ctrl>, <Alt> and <Delete> keys. You can also restart by turning the system Off and back On again. The following message will appear on the screen:

Press to Enter Setup

In general, you press the arrow keys to highlight items, <Enter> to select, the <PgUp> and <PgDn> keys to change entries, <F1> for help and <Esc> to quit. When you enter the Setup utility, the Main Menu screen will appear on the screen. The Main Menu allows you to select from various setup functions and exit choices.

ROM PCI/ISA BIOS
CMOS SETUP UTILITY
AWARD SOFTWARE, INC.

STANDARD CMOS SETUP	INTEGRATED PERIPHERALS
BIOS FEATURES SETUP	SUPERVISOR PASSWORD
CHIPSET FEATURES SETUP	USER PASSWORD
POWER MANAGEMENT SETUP	IDE HDD AUTO DETECTION
PNP/PCI CONFIGURATION	SAVE & EXIT SETUP
LOAD BIOS DEFAULTS	EXIT WITHOUT SAVING
LOAD SETUP DEFAULTS	
ESC : Quit	↑ ↓ → ← : Select Item
F10 : Save & Exit Setup	(Shift) F2 : Change Color
Time, Date, Hard Disk Type	

The section below the setup items of the Main Menu displays the control keys for this menu. Another section at the bottom of the Main Menu just below the control keys section displays information on the currently highlighted item in the list.

Note: After making and saving system changes with Setup, you find that your computer cannot boot, the Award BIOS supports an override to the CMOS settings that resets your system to its default.

We strongly recommend that you avoid making any changes to the chipset defaults. These defaults have been carefully chosen by both Award and your system manufacturer to provide the absolute maximum performance and reliability.

Standard CMOS Setup

“Standard CMOS Setup” choice allows you to record some basic hardware configurations in your computer system and set the system clock and error handling. If the motherboard is already installed in a working system, you will not need to select this option. You will need to run the Standard CMOS option, however, if you change your system hardware configurations, the onboard battery fails, or the configuration stored in the CMOS memory was lost or damaged.

ROM PCI/ISA BIOS
STANDARD CMOS SETUP
AWARD SOFTWARE, INC.

Date (mm:dd:yy) : Wed, Oct 6 1999							
Time (hh:mm:ss) : 00 : 00 : 00							
		CYLS	HEADS	PRECOMP	LANDZ	SECTOR	MODE
Master IDE	(0MB)	0	0	0	0	0	Auto
Slave IDE	(0MB)	0	0	0	0	0	Auto
Drive A	: 1.44M, 3.5in						
Drive B	: None						
LCD&CRT	: Both						
Halt On	: All Errors						
				Base Memory		: 640K	
				Extended Memory		: 15360K	
				Other Memory		: 384K	
				Total Memory		: 16384K	
ESC : Quit		↑ ↓ → ← : Select Item			PU / PD / + / - : Modify		
F1 : Help		(Shift) F2 : Change Color					

At the bottom of the menu are the control keys for use on this menu. If you need any help in each item field, you can press the <F1> key. It will display the relevant information to help you. The memory display at the lower right-hand side of the menu is read-only. It will adjust automatically according to the memory changed. The following describes each item of this menu.

Date

The date format is:

Day	Sun to Sat (read only)
Month	1 to 12
Date	1 to 31
Year	1994 to 2079

To set the date, highlight the “Date” field and use the PageUp/ PageDown or +/- keys to set the current time.

Time

The time format is:

Hour	00 to 23
Minute	00 to 59
Second	00 to 59

To set the time, highlight the “Time” field and use the <PgUp>/ <PgDn> or +/- keys to set the current time.

Primary HDDs / Secondary HDDs

The onboard PCI IDE connectors provide Primary and Secondary channels for connecting up to four IDE hard disks or other IDE devices. Each channel can support up to two hard disks; the first is the “Master” and the second is the “Slave”.

To enter the specifications for a hard disk drive, you must select a “Type”. There are 45 predefined types and 4 user definable types are for Enhanced IDE BIOS. Type 1 to 45 are predefined. [Type “User” is user-definable. For the Primary Master/Slave as well as Secondary Master/Slave, you can select “Auto” under the TYPE and MODE fields. This will enable auto detection of your IDE drives and CD-ROM drive during POST.]

Press <PgUp>/<PgDn> to select a numbered hard disk type or type the number and press the <Enter> key. The hard disk will not work properly if you enter incorrect information for this field. If your hard disk drive type is not matched or listed, you can use Type User to define your own drive type manually. If you select Type User, related information is asked to be entered to the following items.

CYLS.	Number of cylinders
HEADS	Number of read/write heads
PRECOMP	Write precompensation
LANDZONE	Landing zone
SECTORS	Number of sectors

The SIZE item automatically adjust according to the configuration.

MODE (for IDE HDD only) :

Auto <Default>	Auto-detect the HDD mode
Normal	HD < 528MB
Large	For MS-DOS only
LBA	HD > 528MB and supports Logical Block Addressing

Note: The specifications of your drive must match with the drive table. The hard disk will not work properly if you enter incorrect information in these fields. If your hard disk drive type is not matched or listed, you can use Type User to define your own drive type manually.

Drive A / Drive B

These fields identify the types of floppy disk drive A or drive B that has been installed in the computer. The available specifications are:

None	No floppy drive be installed
360KB 5.25 in.	5.25 inch floppy drive, 360KB capacity
1.2MB 5.25 in.	5.25 in. floppy drive, 1.2MB capacity
720KB 3.5 in.	3.5 in. floppy drive, 720KB capacity
1.44MB 3.5 in. <Default>	3.5 in. floppy drive, 1.44MB capacity
2.88MB 3.5 in.	3.5 in. floppy drive, 2.88MB capacity

LCD&CRT

The NuPRO-590 CPU board can supports two display interfaces, Panel and CRT, concurrently. This field selects the interface of video display. You can choose the following display interface:

Auto	Auto-detect the display interface installed in your system
Both	Both CRT & LCD are display interface
CRT <Default>	Use CRT monitor as display interface
LCD	Use LCD Panel as display interface

If you install an LCD panel on the NuPRO-595 CPU board, you can also select the panel type in the "POWER MANAGEMENT SETUP" section.

Halt On

This field determines whether the system will halt if an error is detected during power up.

No Errors	The system boot will not be halted for any error that may be detected.
All Errors <Default>	Whenever the BIOS detects a non-fatal error, the system will stop and you will be prompted.
All, But Keyboard	The system boot will not be halted for a keyboard error; it will stop for all other errors
All, But Diskette	The system boot will not be halted for a disk error; it will stop for all other errors.
All, But Disk/Key	The system boot will not be halted for a keyboard or disk error; it will stop for all others.

BIOS Features Setup

This section allows you to configure and improve your system and allows you to set up some system features according to your preference.

ROM / PCI ISA BIOS
 BIOS FEATURES SETUP
 AWARD SOFTWARE, INC.

Virus Warning : Disabled CPU Internal Cache : Enabled External Cache : Enabled Quick Power On Self Test : Enabled Boot From LAN First : Disabled Boot Sequence : A, C, SCSI Swap Floppy Drive : Disabled Boot Up Floppy Seek : Enabled Boot Up Numlock Status : On Boot Up System Speed : Low Gate A20 Option : Fast Typematic Rate Setting : Disabled Typematic Rate (chars/Sec) : 6 Typematic Delay (Msec) : 250 Security Option : Setup PCI /VGA Palette Snoop : Disabled OS Select For DRAM>64MB : Non-OS2	Video BIOS Shadow : Enabled C8000-CBFFF Shadow : Disabled CC000-CFFFF Shadow : Disabled D0000-D3FFF Shadow : Disabled D4000-D7FFF Shadow : Disabled D8000-DBFFF Shadow : Disabled DC000-DFFF Shadow : Disabled ESC : Quit ↑ ↓ → ← : Select Item F1 : Help PU/PD/+/- : Modify F5 : Old Values (Shift) F2 : Color F6 : Load BIOS Defaults F7 : Load Setup Defaults
---	--

Virus Warning

Enabled	This item protects the boot sector and partition table of your hard disk against accidental modifications. If an attempt is made, the BIOS will halt the system and display a warning message. If this occurs, you can either allow the operation to continue or run an anti-virus program to locate and remove the problem.
Disabled <Default>	No warning message appears

Note: Many disk diagnostic programs, which attempt to access the boot sector table, can cause the virus warning. If you will run such a program, disable the Virus Warning feature.

CPU Internal Cache / External Cache

Cache memory is additional memory that is much faster than conventional DRAM (system memory). CPUs from 486-type on contain internal cache memory, and most, but not all, modern PCs have additional (external) cache memory. When the CPU requests data, the system transfers the requested data from the main DRAM into cache memory, for even faster access by the CPU. These items allow you to enable (speed up memory access) or disable the cache function.

Enabled <Default>	Open CPU Internal Cache / External Cache
Disabled	Close CPU Internal Cache / External Cache

Quick Power On Self Test

When enabled, this field speeds up the Power On Self Test (POST) after the system is turned on. If it is set to *Enabled*, BIOS will skip some items.

Enabled <Default>	Enable quick POST
Disabled	Normal POST

Boot From LAN First

This field allows you to use a bootable LAN device to boot the system first.

Enabled	Boot the system from LAN first
Disabled <Default>	Boot from the device on the system

Boot Sequence

This field determines the drive that the system searches first for an operating system. The options are :

A, C, SCSI <Default>	D, A, SCSI	SCSI, C, A
C, A, SCSI		C only
C, CDROM, A		ZIP100, C
CDROM, C, A	SCSI, A, C	LS120,C

Swap Floppy Drive

This item allows you to determine whether to enable Swap Floppy Drive or not.

Enabled	The BIOS swaps floppy drive assignments so that Drive A becomes Drive B, and Drive B becomes Drive A.
Disabled <Default>	Disable the BIOS to swap floppy drive

Boot Up Floppy Seek

Enabled <Default>	The BIOS will seek whether or not the floppy drive installed has 40 or 80 tracks. 360K type has 40 tracks while 760K, 1.2M and 1.44M all have 80 tracks
Disabled	BIOS will not search the type of floppy disk drive by track number

Boot Up NumLock Status

On <Default>	Keypad is number keys
Off	Keypad is arrow keys

Boot Up System Speed

High <Default>	Set the speed to high
Low	Set the speed to low

Gate A20 Option

This field allows you to select how Gate A20 is worked. Gate A20 is a device used to address memory above 1 MB.

Fast <Default>	The A20 signal controlled by chipset specific method
Normal	The A20 signal controlled by keyboard controller or chipset hardware

Typematic Rate Setting

Enabled	Enable typematic rate and typematic delay programming
Disabled <Default>	Disable typematic rate and typematic delay programming. The system BIOS will use default value of these 2 items And the default controlled by keyboard

Typematic Rate (Chars/Sec)

When the typematic rate is enabled, the system registers repeated keystrokes speeds. You can select speed range from 6 to 30 characters per second. By default, this item is set to **6**.

Typematic Delay (Msec)

When the typematic rate is enabled, this item allows you to set the time interval for displaying the first and second characters. By default, this item is set to **250msec**

Security Option

This field allows you to limit access to the System and Setup.

Setup <Default>	The system always boots up and prompts for the Supervisor Password only when the Setup utility is called up
System	The system prompts for the User Password every time you boot up

Note: To disable security, select PASSWORD SETTING at Main Menu and then you will be asked to enter the password. If you do not type anything and just press <Enter> key, it will disable security. Once the security is disabled, you can boot up the system and access to Setup freely.

PCI/VGA Palette Snoop

Some non-standard VGA display boards may not show colors properly. This field allows you to set whether MPEG ISA/VESA VGA Boards can work with PCI/VGA or not.

Enabled	PCI/VGA can work with MPEG ISA/VESA VGA board
Disabled <Default>	PCI/VGA can not work with MPEG ISA/VESA VGA board

OS Select for DRAM > 64MB

This option allows the system to access greater than 64MB of DRAM memory when used with OS/2 that depends on certain BIOS calls to access memory. The default setting is **Non-OS/2**.

Video BIOS Shadow

This item allows you to change the Video BIOS location from ROM to RAM. Video Shadow will increase the video speed.

Enabled <Default>	Video shadow is enabled
Disabled	Video shadow is disabled

C8000 - CBFFF Shadow/DC000 - DFFFF Shadow

Shadowing a ROM reduces the memory available between 640KB to 1024KB. These fields determine whether optional ROM will be copied to RAM or not.

Enabled	Optional shadow is enabled
Disabled <Default>	Optional shadow is disabled

Chipset Features Setup

This Setup menu controls the configuration of the chipset.

ROM PCI/ISA BIOS
CHIPSET FEATURES SETUP
AWARD SOFTWARE INC.

*Auto Configuration	: Disabled	Power-Supply Type	: AT
		Spread Spectrum	: Disabled
*DRAM Leadoff Timing	: 11/7/3	Case Open_Warning	: Enabled
*DRAM Read Burst (EDO/FP)	: X444/x444	CPU Warning Temperature	: Disabled
*DRAM Write Burst Timing	: X444	Current System Temp.	: 60°C/140°F
*Fast EDO Lead Off	: Disabled	Current CPU1 Temperature	:
*Refresh RAS# Assertion	: 5 Clks	Current CPUFAN1 Speed	:
*Fast RAS To CAS Delay	: 3	VCORE	:
*DRAM Page Idle Timer	: 2 Clks	3.3 V	: +5 V
*DRAM Enhanced Paging	: Enabled	+12V	: -12 V
*Fast MA to RAS# Delay	: 2 Clks		
*SDRAM(CAS Lat/RAS-to-CAS)	: 2/2		
*SDRAM Speculative Read	: Disabled		
System BIOS Cacheable	: Disabled	ESC : Quit	↑ ↓ → ← : Select Item
Video BIOS Cacheable	: Disabled	F1 : Help	PU/PD/+/- : Modify
8 Bit I/O Recovery Time	: NA	F5 : Old Values	(Shift) F2 : Color
16 Bit I/O Recovery Time	: NA	F6 : Load BIOS Defaults	
Memory Hole At 15M-16M	: Disabled	F7 : Load Setup Defaults	
Auto Detect DIMM/PCI Clk	: Enabled		

Note: The items that be marked in this menu are show-only. The system manufacturer for high performance configures the item value.

System BIOS Cacheable

When this function is enabled, the BIOS ROMs addresses at F0000H-FFFFFH will be duplicated into the SRAM. It will work with the cache controller that is enabled.

Enabled <Default>	BIOS access cached
Disabled	BIOS access not cached

Video BIOS Cacheable

As with caching the system BIOS above, enabling the Video BIOS cache will cause access to video BIOS addressed at C0000H to C7FFFH to be cached, if the cache controller is also enabled.

Enabled <Default>	Video BIOS access cached
Disabled	Video BIOS access not cached

8 Bit I/O Recovery Time

The recovery time is the length of time, which the system delays after the completion of an input/output request. The CPU clocks measure it. This delay takes place because the CPU is operating much faster than the input/output bus that the CPU must be delayed to allow for the completion of the I/O.

This option specifies the length of the delay (in sysclks) inserted between consecutive 8-bit I/O operations. The settings are 1, 2, 3, 4, 5, 6, 7, or 8. The default setting is **NA**.

16 Bit I/O Recovery Time

This option specifies the length of the delay (in sysclks) inserted between consecutive 16-bit I/O operations. The settings are 1, 2, 3, 4. The default setting is **NA**.

Memory Hole at 15MB - 16MB

In order to improve performance, certain space in memory can be reserved for ISA boards. This field allows you to reserve 15MB to 16MB memory address space to ISA expansion boards. This makes memory from 15MB and up unavailable to the system. Expansion boards can only access memory up to 16MB. By default, this field is set to **Disabled**.

Auto Detect DIMM/PCI Clk

When enabled, the system automatically shuts off clocks of unused DIMM/PCI slots. The default setting is **Disabled**.

Power-Supply Type

AT<Default>	This power supply is reserved for traditional system that uses the AT power supply.
ATX	The ATX power supply is used for more functions about the system's power management. Some wake up event function is provided by this type power supply.

Spread Spectrum

This field sets the value of the spread spectrum. Options are Disabled, 1.8% (CNTR), 0.6% (CNTR), 1.8% (DOWN), and 0.6% (DOWN). The default setting is **Disabled**. This field is for CE testing use only.

Case_Open Warning

When the system is power on, to open the system's case may causes accidental damage. If this field enabled, it alarms by speaker beeping. You must turn off the power and close the system's case to disable the beeping. The default setting is **Disabled**.

CPU Warning Temperature

This field sets the threshold temperature at which an alert is sounded through the system's speaker. The CPU temperature is monitored by the onboard thermal sensor to prevent the CPU from overheating.

Current System/CPU Temperature

These read-only fields reflect the functions of the hardware thermal sensor that monitors the CPU and system temperatures to ensure the system is stable.

Current CPU Fan Speed

These read-only fields show the current speeds in RPM (revolution per minute) for the CPU fan and chassis fan as monitored by the hardware monitoring IC.

VCORE/3.3V/+12V/-12V/+5V

These read-only fields show the current voltages in the voltage regulators and power supply as monitored by the hardware monitoring IC.

Shutdown Temperature

This field allows you to set the temperature at which the system automatically shuts down once it is reached, in order to avoid damage to system components.

PM Control by APM

This field allows you to use the Advanced Power Management device to enhance the Max. Power Saving mode and stop the CPU's internal clock. The default setting of this field is **Yes**.

Video Off Method

This field defines the Video Off features. There are three options.

V/HSYNC + Blank <Default>	This selection will cause the system to turn off the Vertical and horizontal synchronization ports and Write blanks to the video buffer
DPMS	Allows the BIOS to control the video display board if it supports the DPMS feature
Blank Screen	This option only writes blanks to the video buffer

Video Off After

As the system moves from lesser to greater power-saving modes, select the mode in which you want the monitor to blank. There are four options.

NA	The monitor will not be blank
Doze	When the system enter Doze mode, the Video off.
Standby <Default>	In Standby mode, the Video off.
Suspend	In Suspend mode, the Video off.

Modem Use IRQ

This field names the interrupt request (IRQ) line assigned to the modem (if any) on your system. Activity of theselected IRQ always awakens the system. By default, the IRQ is set to **3**.

Doze Mode

When enabled, and after the set time of system inactivity, the CPU clock will run at a slower speed while all other devices still operate at full speed.

Disabled <Default>	Don't Enter the Doze mode
1 Hour	After 1 hour of system inactivity, enter Doze mode
40 min	After 40 min of system inactivity, enter Doze mode
30 min	After 30 min of system inactivity, enter Doze mode
20 min	After 20 min of system inactivity, enter Doze mode
12 min	After 12 min of system inactivity, enter Doze mode
8 min	After 8 min of system inactivity, enter Doze mode
4 min	After 4 min of system inactivity, enter Doze mode
2 min	After 2 min of system inactivity, enter Doze mode
1 min	After 1 min of system inactivity, enter Doze mode

Standby Mode

After the selected period of system inactivity, the fixed disk drive and the video shut off while all other devices still operate at full speed.

Disabled <Default>	Don't Enter the Standby mode
1 Hour	After 1 hour of system inactivity, enter Standby mode
40 min	After 40 min of system inactivity, enter Standby mode
30 min	After 30 min of system inactivity, enter Standby mode
20 min	After 20 min of system inactivity, enter Standby mode
12 min	After 12 min of system inactivity, enter Standby mode
8 min	After 8 min of system inactivity, enter Standby mode
4 min	After 4 min of system inactivity, enter Standby mode
2 min	After 2 min of system inactivity, enter Standby mode
1 min	After 1 min of system inactivity, enter Standby mode

Suspend Mode

When enabled, and after the set time of system inactivity, all devices except the CPU will be shut off.

Disabled <Default>	Don't Enter the Suspend mode
1 Hour	After 1 hour of system inactivity, enter Suspend mode
40 min	After 40 min of system inactivity, enter Suspend mode
30 min	After 30 min of system inactivity, enter Suspend mode
20 min	After 20 min of system inactivity, enter Suspend mode
12 min	After 12 min of system inactivity, enter Suspend mode
8 min	After 8 min of system inactivity, enter Suspend mode
4 min	After 4 min of system inactivity, enter Suspend mode
2 min	After 2 min of system inactivity, enter Suspend mode
1 min	After 1 min of system inactivity, enter Suspend mode

HDD Power Down

When enabled, and after the set time of system inactivity, the hard disk drive will be powered down while all other devices remain active.

Disabled <Default>	Don't Enter the HDD power down mode
1 min ~ 15 min	After the set time of system inactivity, HDD power down

Throttle Duty Cycle

When the system enters Doze mode, the CPU clock runs only part of the time. You may select the percent of time that the clock runs.

75.0%	75.0% time that the CPU clock runs
62.5% <Default>	62.5% time that the CPU clock runs
50.0%	50.0% time that the CPU clock runs
37.5%	37.5% time that the CPU clock runs
25.0%	25.0% time that the CPU clock runs
12.5%	12.5% time that the CPU clock runs

ZZ Active In Suspend

The ZZ signal is used to power down a cache's data SRAMs when the clock logic places the CPU into the stop clock.

Enabled	Enable the ZZ signal to power down cache's SRAM
Disabled <Default>	Disable the ZZ signal when in suspend mode

PCI/VGA Act-Monitor

When enabled, any video activity restarts the global timer for Standby mode. The default setting is *Enabled*.

Soft-Off by PWR-BTTN

This field defines the power-off mode when using an ATX power supply. There are two modes :

Instant-Off <Default>	The mode allows powering off immediately upon pressing the power button
Delay 4 Sec	The system powers off when the power button is pressed for more than four seconds or places the system in a very low-power-usage state, with only enough circuitry receiving power to detect power button activity.

CPUFAN Off In Suspend

The fan of CPU is stopped by the BIOS when in Suspend mode.

Enabled <Default>	The fan of CPU stops in suspend mode.
Disabled	The fan is always active.

PowerOn by Ring/Wake Up On Lan

Enabled <Default>	Wake up the system from modem or lan
Disabled	Disable the modem or lan to wake up the system

IRQ 8 Break Suspend

You can enable or disable the monitoring of IRQ 8 (Real Time Clock) so it does not awaken the system from Suspend mode.

Reload Global Timer Events

This section determines the reloading of the 'timers' after entering the Full On. You can enable or disable the monitoring of IRQ 8 (Real Time Clock) so it does not awaken the system from Suspend mode.

PM Events

The VGA, LPT & COM, HDD & FDD, DMA /master, PWR-On by Modem/LAN, RTC Alarm Resume and Primary NTR section are I/O events which can prevent the system from entering a power saving mode or can awaken the system from such a mode. When an I/O device wants to gain the attention of the operating system, it signals this by causing an IRQ to occur. When the operating system is ready to respond to the request, it interrupts itself and performs the service. If activity is detected from any enabled IRQ channels, the system wakes up from suspended mode.

Panel Type Selectable

If there installs a LCD panel on the system, you can also select the panel type in this item. There are 16 panel types can be selected.

Panel-16	1024x768 Dual Scan STN Color Panel
Panel-1	1280x1024 TFT Color Panel
Panel-2	640x480 Dual Scan STN Color Panel
Panel-3	800x600 Dual Scan STN Color Panel
Panel-4	640x480 Sharp TFT Color Panel
Panel-5 <Default>	640x480 18-bit TFT Color Panel
Panel-6	1024x768 TFT Color Panel
Panel-7	800x600 TFT Color Panel
Panel-8	800x600 TFT Color Panel (Large BIOS only)

Panel-9	800x600 TFT Color Panel (Large BIOS only)
Panel-10	800x600 Dual Scan STN Color Panel (Large BIOS only)
Panel-11	800x600 Dual Scan STN Color Panel (Large BIOS only)
Panel-12	1024x768 TFT Color Panel (Large BIOS only)
Panel-13	1280x1024 Dual Scan STN Color Panel (Large BIOS only)
Panel-14	1024x600 Dual Scan STN Color Panel (Large BIOS only)
Panel-15	1024x600 TFT Color Panel (Large BIOS only)

PNP/PCI Configuration

This option configures the PCI bus system. All PCI bus systems on the system use INT#, thus all installed PCI boards must be set to this value.

ROM PCI/ISA BIOS
PNP/PCI CONFIGURATION
AWARD SOFTWARE INC.

PNP OS Installed	: No	PCI IDE IRQ Map To	: PCI-AUTO
Resources Controlled by	: Manual	Primary IDE INT#	: A
Reset Configuration Data	: Disabled	Secondary IDE INT#	: B
IRQ-3 assigned to	: Legacy ISA	Used MEM base addr	: N/A
IRQ-4 assigned to	: Legacy ISA		
IRQ-5 assigned to	: PCI/ISA PnP		
IRQ-7 assigned to	: Legacy ISA		
IRQ-9 assigned to	: PCI/ISA PnP		
IRQ-10 assigned to	: PCI/ISA PnP		
IRQ-11 assigned to	: PCI/ISA PnP		
IRQ-12 assigned to	: PCI/ISA PnP		
IRQ-14 assigned to	: PCI/ISA PnP		
IRQ-15 assigned to	: PCI/ISA PnP		
DMA-0 assigned to	: PCI/ISA PnP		
DMA-1 assigned to	: PCI/ISA PnP	ESC : Quit	↑ ↓ ← → : Select Item
DMA-3 assigned to	: PCI/ISA PnP	F1 : Help	PU/PD/+/- : Modify
DMA-5 assigned to	: PCI/ISA PnP	F5 : Old Values	(Shift) F2 : Color
DMA-6 assigned to	: PCI/ISA PnP	F6 : Load BIOS Defaults	
DMA-7 assigned to	: PCI/ISA PnP	F7 : Load Setup Defaults	

PNP OS Installed

This field allows you to specify if the operating system installed in your system is plug and play aware.

Note: Operating systems such as DOS, OS/2, and Windows 3.x do not use PnP.

Yes	Operating system supports PnP device
No <Default>	Operating system doesn't support PnP device

Resources Controlled by

This PnP BIOS can configure all of the boot and compatible devices automatically. However, this capability needs you to use a PnP operating system such as Windows 95.

Auto <Default>	PnP BIOS configure all compatible devices automatically
Manual	User can assign IRQ & DMA to the devices

Reset Configuration Data

This field allows you to determine whether to reset the configuration data or not. The default value is **Disabled**.

IRQ3/4/5/7/9/10/11/12/14/15, DMA0/1/3/5/6/7 assigned to

These fields allow you to determine the IRQ/DMA assigned to the ISA bus and is not available to any PCI slot.

PCI IDE IRQ Map To

PCI-AUTO <Default>	BIOS will scan for PCI IDE devices & determine the location of the PCI IDE device and assign IRQ 14 for primary IDE INT#, IRQ 15 for secondary IDE INT#
PCI-SLOT1/2/3/4	BIOS assign IRQ 14 for primary IDE INT#, IRQ 15 for secondary IDE INT# for the specified slot
ISA	The BIOS will not assign any IRQs even if PCI IDE board is found. Because some IDE boards connect the IRQ 14 & 15 directly from ISA slot thru a cord . (This cord is called Legacy Header)

Primary IDE INT#/Secondary IDE INT#

To tell which INT# does the PCI IDE board is using for its interrupts

Used MEM base addr

Select a base address for the memory area used by any peripheral that requires high memory. The default setting is **N/A**.

Load BIOS Defaults

This option allows you to load the troubleshooting default values permanently stored in the BIOS ROM. These default settings are non-optimal and disable all high-performance features.

ROM PCI/ISA BIOS
CMOS SETUP UTILITY
AWARD SOFTWARE, INC.

STANDARD CMOS SETUP	INTEGRATED PERIPHERALS
BIOS FEATURES SETUP	SUPERVISOR PASSWORD
CHIPSET FEATURES SETUP	USER PASSWORD
POWER MANAG	DETECTION
PNP/PCI CONFIC	FORMAT
Load BIOS Defaults (Y/N)? N	UP
LOAD SETUP DEFALTS	EXIT WITHOUT SAVING
ESC : Quit	↑ ↓ → ← : Select Item
F10 : Save & Exit Setup	(Shift) F2 : Change Color
Load BIOS Defaults except Standard CMOS Setup	

To load BIOS defaults value to CMOS SRAM, enter "Y". If not, enter "N".

Load Setup Defaults

This option allows you to load the default values to your system configuration. These default settings are optimal and enable all high performance features.

ROM PCI/ISA BIOS
CMOS SETUP UTILITY
AWARD SOFTWARE, INC.

STANDARD CMOS SETUP	INTEGRATED PERIPHERALS
BIOS FEATURES SETUP	SUPERVISOR PASSWORD
CHIPSET FEATURES SETUP	USER PASSWORD
POWER MAN	DETECTION
PNP/PCI CON	EL FORMAT
LOAD BIOS D	ETUP
Load Setup Defaults (Y/N)? N	EXIT WITHOUT SAVING
ESC : Quit	↑ ↓ → ← : Select Item
F10 : Save & Exit Setup	(Shift) F2 : Change Color
Load BIOS Defaults except Standard CMOS Setup	

To load SETUP defaults value to CMOS SRAM, enter "Y". If not, enter "N".

Integrated Peripherals

This option sets your hard disk configuration, mode and port.

ROM PCI/ISA BIOS
INTEGRATED PERIPHERALS
AWARD SOFTWARE INC.

IDE HDD Block Mode : Enabled IDE Primary Master PIO : Auto IDE Primary Slave PIO : Auto IDE Primary Master UDMA : Auto IDE Primary Slave UDMA : Auto On-Chip Primary PCI IDE : Enabled USB Keyboard Support : Disabled Onboard Lan Chip : Enabled Onboard VGA Chip : Enabled KBC input clock : 6 MHz Onboard FDC Controller : Enabled Onboard Serial Port 1 : 3F8/IRQ4 Onboard Serial Port 2 : 2F8/IRQ3 UART Mode Select : Normal UART2 Duplex Mode : Full RxD , TxD Active : Hi , Hi IR Transmission delay : Disabled	Onboard Parallel Port : 378/IRQ7 Parallel Port Mode : SPP ECP Mode Use DMA : 1 EPP Mode Select : EPP1.9 ESC : Quit ↑ ↓ ← : Select Item F1 : Help PU/PD/+/- : Modify F5 : Old Values (Shift) F2 : Color F6 : Load BIOS Defaults F7 : Load Setup Defaults
--	--

IDE HDD Block Mode

This field allows your hard disk controller to use the fast block mode to transfer data to and from your hard disk drive.

Enabled<Default>	IDE controller uses block mode
Disabled	IDE controller uses standard mode

IDE Primary Master/Slave PIO

These fields allow your system hard disk controller to work faster. Rather than have the BIOS issue a series of commands that transfer to or from the disk drive, PIO (Programmed Input/Output) allows the BIOS to communicate with the controller and CPU directly.

The system supports five modes, numbered from 0 (default) to 4, which primarily differ in timing. When Auto is selected, the BIOS will select the best available mode.

Auto<Default>	Auto select which mode that BIOS communicates with the controller and CPU
Mode0~Mode4	User define the PIO mode

IDE Primary Master/Slave UDMA

These fields allow your system to improve disk I/O throughput to 33Mb/sec with the Ultra DMA/33 feature. The options are *Auto <Default>* and *Disabled*.

On-Chip Primary PCI IDE

The integrated peripheral controller contains an IDE interface with support for two IDE channels. Select *Enabled* to activate each channel separately.

USB Keyboard Support

Select *Enabled* if your system contains a Universal Serial Bus (USB) controller and you have a USB keyboard.

Onboard Lan Chip/Onboard VGA Chip

The default setting of *Enabled* enables the onboard Lan/onboard VGA function of the system

KBC Input Clock

This field decides which clock frequency of keyboard controller is used. The default option is *8MHz*.

Onboard FDC Controller

Select *Enabled* if your system has a floppy disk controller (FDC) installed on the system and you wish to use it. If you install an add-in FDC or the system has no floppy drive, select *Disabled* in this field. This option allows you to select the onboard FDD port.

Onboard Serial Port

These fields allow you to select the onboard serial ports and their addresses. The default values for these ports are:

Serial Port 1	3F8/IRQ4
Serial Port 2	2F8/IRQ3

UART Mode Select

This field determines the UART mode in your computer. The settings are *Normal*, *IrDA* and *ASKIR*. The default value is *Normal*.

Onboard Parallel Port

These fields allow you to select the onboard parallel ports and their addresses. The default value for this port is:

Parallel Port	378H/IRQ7
---------------	-----------

Parallel Port Mode

This field allows you to determine parallel port mode function.

SPP	(Standard Parallel Port) normal Printer Port, 150KB/sec transfer speed
EPP	(Enhanced Parallel Port), 2MB/sec transfer speed, the system supports EPP 1.7 and EPP 1.9
ECP	(Extended Capabilities Port), 4MB/sec transfer speed

Supervisor / User Password

These two options set the system password. Supervisor Password sets a password that will be used to protect the system and Setup utility. User Password sets a password that will be used exclusively on the system. To specify a password, highlight the type you want and press <Enter>. The Enter Password: message prompts on the screen. Type the password, up to eight characters in length, and press <Enter>. The system confirms your password by asking you to type it again. After setting a password, the screen automatically returns to the main screen.

To disable a password, just press the <Enter> key when you are prompted to enter the password. A message will confirm the password to be disabled. Once the password is disabled, the system will boot and you can enter Setup freely.

ROM PCI/ISA BIOS
CMOS SETUP UTILITY
AWARD SOFTWARE, INC.

STANDARD CMOS SETUP	INTEGRATED PERIPHERALS
BIOS FEATURES SETUP	SUPERVISOR PASSWORD
CHIPSET FEATURES SETUP	USER PASSWORD
POWER MANAGEMENT SETUP	DETECTION
PNP/PCI CONFIGURATION	FILE FORMAT
LOAD BIOS DEFAULTS	SETUP
LOAD SETUP DEFAULTS	EXIT WITHOUT SAVING
ESC : Quit	↑ ↓ → ← : Select Item
F10 : Save & Exit Setup	(Shift) F2 : Change Color
Change / Set / Disable Password	

IDE HDD Auto Detection

This option detects the parameters of an IDE hard disk drive, and automatically enters them into the Standard CMOS Setup screen.

ROM PCI/ISA BIOS
STANDARD CMOS SETUP
AWARD SOFTWARE, INC.

HARD DISKS	TYPE	SIZE	CYLS	HEAD	PRECOMP	LANDZ	SECTOR	MODE
Primary Master:								
Select Primary Master Option (N=SKIP) : N								
OPTIONS	TYPE	SIZE	CYLS	HEAD	PRECOMP	LANDZ	SECTOR	MODE
1 (Y)	0	0	0	0	0	0	0	NORMAL
NOTE: Some OSes (like SCO-UNIX) must use "NORMAL" for installation								

ESC: SKIP

Up to two IDE drives can be detected, with parameters for each appearing in sequence inside a box. To accept the displayed entries, press the "Y" key, to skip to the next drive, press the "N" key. If you accept the values, the parameters will appear listed beside the drive letter on the screen.

Save & Exit Setup

This option allows you to determine whether to accept the modifications or not. If you type "Y", you will quit the setup utility and save all changes into the CMOS memory. If you type "N", you will return to Setup utility.

ROM PCI/ISA BIOS
CMOS SETUP UTILITY
AWARD SOFTWARE, INC.

STANDARD CMOS SETUP	INTEGRATED PERIPHERALS
BIOS FEATURES SETUP	SUPERVISOR PASSWORD
CHIPSET FEATURES SETUP	USER PASSWORD
POWER MANAGEMENT SETUP	IDE HDD AUTO DETECTION
PNP/PCI CONF	LEVEL FORMAT
LOAD BIOS D	SETUP
LOAD SETUP	SAVING
ESC : Quit	↑ ↓ → ← : Select Item
F10 : Save & Exit Setup	(Shift) F2 : Change Color
Save Data to CMOS & Exit Setup	

Exit Without Saving

Select this option to exit the Setup utility without saving the changes you have made in this session. Typing "Y" will quit the Setup utility without saving the modifications. Typing "N" will return you to Setup utility.

ROM PCI/ISA BIOS
CMOS SETUP UTILITY
AWARD SOFTWARE, INC.

STANDARD CMOS SETUP	INTEGRATED PERIPHERALS
BIOS FEATURES SETUP	SUPERVISOR PASSWORD
CHIPSET FEATURES SETUP	USER PASSWORD
POWER	UTO DETECTION
PNP/PCI	LEVEL FORMAT
LOAD BI	IT SETUP
LOAD SET	EXIT WITHOUT SAVING
ESC : Quit	↑ ↓ → ← : Select Item
F10 : Save & Exit Setup	(Shift) F2 : Change Color
Abandon all Data & Exit Setup	

4

Intel PIIX Bus Master IDE Driver Installation

This chapter describes the installation procedure for Intel PCI ISA IDE Xcelerator(PIIX) Bus Master IDE Drivers for Windows 95.

This chapter contains the following sections:

System Requirements61

Installing the Software61

4.1 System Requirements

This section describes system requirements for the PIIX Bus Master IDE Device Driver for Windows 95 . This driver has been designed for and tested with Windows 95 only. This driver will only install on systems with Windows 95.

1. The system must contain a supported Intel processor and chipset configuration.
2. Ensure that a mouse is connected to the system.
3. One of the following versions of Windows 95 must be installed on the system prior to running utility program.

Windows 95 4.00.950 (Retail)

Windows 95 4.00.950a (OSR1)

Windows 95 4.00.950b (OSR2 without USB Supplement)

Windows 95 4.00.950b (OSR2.1 with USB Supplement)

4. This utility should only be used on desktop systems. The utility must not be executed on notebook or portable systems with or without dock.
5. It is assumed that the BIOS properly initialized the 82371xB IDE interface for Bus Master IDE operation.
6. There is no other non-82371xB IDE controllers (add-in IDE controller or sound board with IDE) enabled on the system.

4.2 Installing the Software

This subsection describes how to install the software on a system where Windows 95 is installed.

Note: Record the location of the Windows 95 directory before installing the driver.

1. Check the System Requirements. Windows 95 must be fully installed and running on the system prior to running this software.
2. Close any running applications.
3. Remove references to installed real-mode IDE device drivers in the AUTOEXEC.BAT and CONFIG.SYS files (especially any drivers that control ATAPI CD-ROM and special IDE features). Use the Notepad utility to do this.

The driver files are stored in an integrated application setup program. This program is a Windows 95 program that allows the driver files to be INSTALLED or DE-INSTALLED.

Execute the driver setup program.

Run SETUP.EXE.

4. Click 'Next' on Welcome Screen to read and agree to the license agreement. View the text file and choose File\Exit to close Notepad and continue. NOTE: If you click **No**, program will terminate.
5. Click **Yes** if you agree to continue. NOTE: If you click 'No', the program will terminate.
6. Select **INSTALL**, to install the PIIX Bus Master IDE Device Driver when prompted to do so.

Note: If the driver is currently installed on the system, SETUP will ask you whether or not you want to continue. Follow the prompts on the screen to install the driver if desired.

7. Click 'OK' to restart the system when prompted to do so.
8. Follow the screen instructions and use default settings to complete the setup when Windows 95 is re-started. Upon re-start, Windows 95* will display that it has found an Intel PCI Bus Master IDE controller hardware and is installing hardware for it.

If a **New Hardware Found** dialog box is displayed requesting the location of the drivers, use the mouse to click on the scrollbar and click on the <Windows 95 directory>\System\IOSubSys path:

For example:

Click on **C:\WINDOWS\SYSTEM\IOSUBSYS**

Click **OK**.

9. Select **Yes**, when prompted to re-start Windows 95.

Note: After installation, the following driver and related files are stored as listed.

<Windows 95 directory>\System\IOSubSys\IDEATAPI.MPD

<Windows 95 directory>\System\IOSubSys\PIIXVSD.VXD

<Windows 95 directory>\INF\IDEATAPI.INF

5

VGA Driver Installation

This chapter provides information on how to install the C&T 69000 VGA drivers that come in the two floppy diskettes with the package. Please follow the instructions set forth in this chapter carefully. Please note that there must be relevant software installed in your system before you could proceed to install the VGA drivers. It is recommended that you make a copy of the VGA driver diskette and put the backup copy in a safe place.

5.1 Installing the Drivers for Windows 95

The following section describes the normal display driver installation procedures for Windows 95. Use the following procedures when installing the display drivers for Windows 95.

1. Click **Start**. Select **Settings**, then click the **Control Panel** icon.
2. Double click **Display**.
3. Click **Settings**.
4. Click **Advanced Properties**.
5. Click **Change**.
6. Click **Have Disk**
7. Insert the diskette/CD containing the **69000 VGA driver for Windows 95** to the floppy disk drive/CD-ROM drive, then type in **A:\WIN95** (assuming drive A is your floppy disk drive) or type in **D:\NuPRO\NuPRO595\VGA DRIVER\WIN95** (assuming drive D is your CD-ROM drive), and press **Enter**.
8. Select **Chips and Tech. 69000 PCI/AGP**, and then click **OK**. After the files are copied, click **Close**.
9. Click **Yes** to restart your computer and for the new settings to take effect.

5.2 Installing the Drivers for Windows 98

The following section describes the normal display driver installation procedures for Windows 98. Use the following procedures when installing the display drivers for Windows 98.

1. Insert the diskette/CD containing the **C&T 69000 VGA driver for Windows 98** to the floppy disk drive/CD-ROM drive, then run CTW98600.exe. With ADLINK CD , this setup program is located in **\\NuPRO\\NuPRO595\\VGA DRIVER\\WIN98** directory
2. Click **Next**. After all procedures are completed, then click **Finish**.
3. Click **Yes** to restart your computer and for the new settings to take effect.

5.3 Installing the Drivers for Windows NT 4.0

IMPORTANT: You should install the Windows NT 4.0 Service Pack 5 first before installing the C&T 69000 VGA drivers. If you don't have the Windows NT 4.0 Service Pack 5, please contact your software vendor or download it from Microsoft's web site.

The procedures below show you how to install the C&T 69000 VGA drivers for Windows NT 4.0.

1. Boot Windows NT 4.0.
2. Double click the **My Computer** icon.
3. Double click the **Control Panel** icon.
4. Double click the **Display" icon.**
5. Click **Change Display Type.**
6. Click **Change.**
7. Click **Have Disk**, then insert the diskette/CD containing the **C&T 69000 VGA driver for Windows NT 4.0** to the floppy disk drive /CD-ROM drive, then type in **A:\WINNT40** (assuming drive A is your floppy disk drive) or type in **D:\NuPRO\NuPRO595\VGA DRIVER \WINNT40** (assuming drive D is your CD-ROM drive), and press **Enter.**
8. Select Chips Video Accelerator (65545/48/50/54/55 68554 69000), and then click OK.
9. Click **Yes** to copy the drivers from the floppy disk/CD to the hard disk.
10. When copying is done, click **OK.**
11. Click **Close.**
12. Click **OK.**
13. Windows NT 4.0 will prompt you to restart computer. Click **OK** to change the Windows NT configuration.

6

LAN Driver Installation Guide

This chapter describes LAN features and driver installation of the onboard Intel 82559 Ethernet controller.

6.1 Introduction

Intel 82559 is a 32-bit 10/100Mbps Ethernet controller for PCI local bus-compliant PCs. It supports the bus mastering architecture, and Auto-negotiation feature which make it possible to combine one common type of Ethernet cabling – an RJ-45 connector for twisted-pair cabling that can be used for both 10Mbps and 100Mbps connection. Extensive driver support for commonly used network operating systems is also provided.

6.2 Features

- Conforms to the Ethernet IEEE 802.3u standard
 - Compatible with PCI Local Bus Revision 2.1 specification
 - IEEE 802.3u Auto-Negotiation for automatic speed selection
 - Supports Full-Duplex/Half-Duplex Operation
 - Provides 32-bit bus mastering data transfer
 - Supports 10Mbps and 100Mbps operation in a single port
 - Supports remote wake-up (Magic Packet*) in APM and ACPI mode
- * Requires ATX power supply with 5VSB, 720mA

6.3 Software Drivers Support

NetWare ODI Drivers

Novell NetWare 3.x, 4.x, NetWare LAN WorkPlace TCP/IP, Novell LAN Analyzer for NetWare

Packet Drivers

FTP PC/TCP, NCSA TCP/IP

NDIS Drivers

Microsoft LAN Manager V2.x, Windows 3.x, Windows NT 4.0, Windows NT 3.51, Windows 98, Windows 95, SCO3, SCO5; IBM LAN Server 4.0 for DOS and OS/2, and Linux.

6.4 Running Diagnostics

The NuPRO-595 comes with two diskettes containing drivers and diagnostic software supporting the Intel 82559 Ethernet controller. Follow the steps below to use the *Setup Utility*.

1. Run the file `SETUP.EXE` typing `a:\setup` or `D:\NUPRO\NuPRO595\LAN DRIVER\setup.exe` in the DOS prompt, assuming your floppy disk drive is drive A. Upon doing so, the system starts the *Setup Utility* and shows the following screen.

8255x-based PCI EtherExpress™ adapter Setup V4.21

Main Menu

Automatic setup
View adapter configuration
Test adapter
Install network drivers
View Help files
Exit Setup

Choose AUTOMATIC SETUP to view the adapter's configuration, make sure it works properly, and install the software needed to connect to your network.

Help = F1 Exit = Esc Select = ↑↓ Action = ↵

2. Selecting **View adapter configuration** will show the following.

8255x-based PCI EtherExpress™ adapter Setup V4.21

View adapter configuration

Adapter type:.....
Adapter part number:.....
Network address:.....
Interrupt:.....
Bus:.....
Slot:.....
Device:.....
Network speed:.....
Physical layer device:.....
Duplex:.....
Adapter capabilities:
100BaseTX, full or half duplex.
10BaseT, full or half duplex.

Press Enter to continue

Help = F1 Previous = Esc Continue = Enter PCI Advanced = F5

3. Selecting **Test adapter** will show the following screen.

8255x-based PCI EtherExpress™ adapter Setup V4.21

Test adapter

Bus=0 Dev=0Bh Slot=11 Addr=004063001000 IRQ=10
Diagnostic tests:

Adapter tests.....	Passed
Onboard loopback tests.....	Passed
Network test.....	Passed

100Mbps

This adapter works properly

Press Enter to continue

Help = F1 Press Enter to continue

4. Selecting **Install network drivers** will show the following screen.

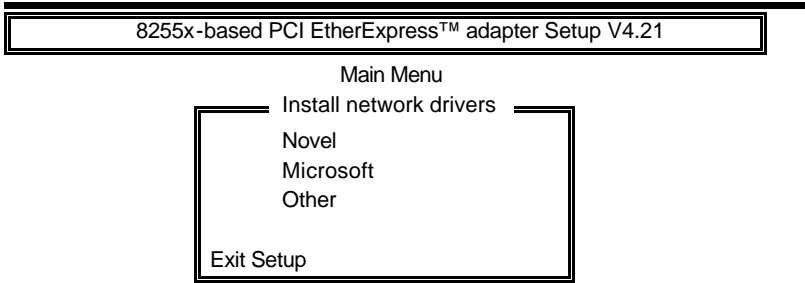

Each of the three items will show the operating procedures for you. Choose OTHER if you use a network operating system from a manufacturer not on this list (such as Banyan or UNIX).

Help = F1 Press Enter to continue

5. Upon selecting **Others** under the **Install network drivers main menu** screen, the following screen will appear.

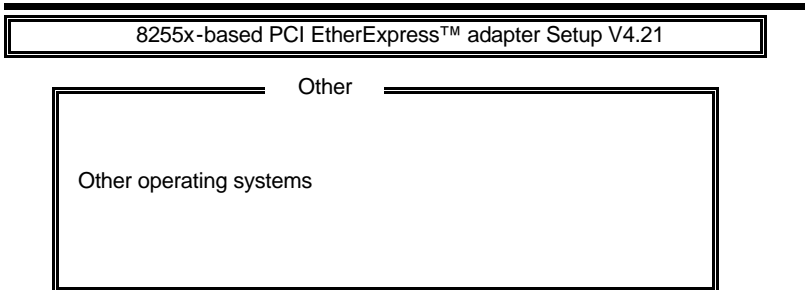

Choose OTHER if you use a network operating system from a manufacturer not on this list (such as Banyan or UNIX).

Help = F1 Previous = Esc Select = ↑↓ Accept = ↵

6. Selecting **View Help files** under the **Main menu** will show the following screen.

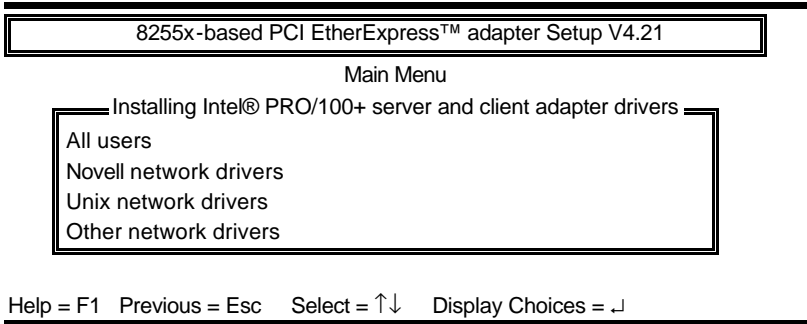

Hardware Doctor Utility

This chapter introduces Hardware Doctor Utility that comes with the CPU board in conjunction with the onboard hardware monitoring IC. The sections in the following pages describe the functions of the utility.

Hardware Doctor is a self-diagnostic system for PC and must be used with Winbond's W83781D IC series products.

It will protect PC Hardware by monitoring several critical items including Power Supply Voltage, CPU Fan speed, and CPU & System temperature.

These items are important to the operation of system; errors may result in permanent hurt of PC. Once any item is out of its normal range, an obvious warning message will pop up and remind user to make a proper treatment.

Note: Hardware Doctor currently supports English and Chinese under Windows 95,98 and Windows NT.

When Hardware Doctor is initiated, the icon below appears in the task bar in the Windows environment.

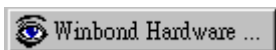

The following screen appears upon clicking on the Hardware Doctor icon.

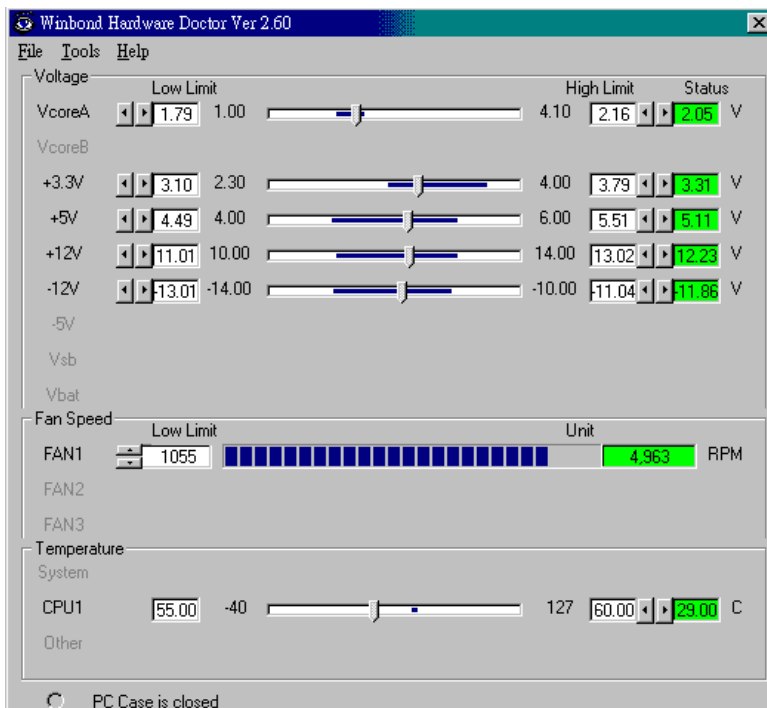

Clicking on the upper left corner button would show you the three items as following:

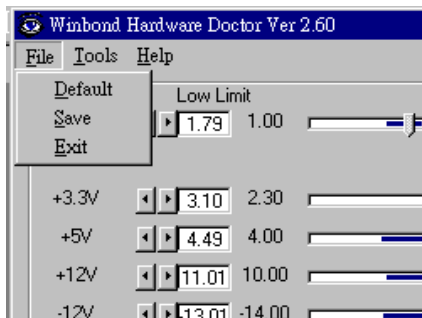

User can set all limits to default value by choosing the “default” item under “file” dialogue window.

Set all Limits to Default:

If users want to change CPU, please set all limits to default after replacing new CPU and the CPU working voltage Vcore will be load automatically. When Change another CPU, please see Default. Save the Setting Limits

Limit Adjustment:

All limits by users can be modified and saved. When users execute this program next time, the limit will be the modified value.

Current Status:

This column is the current status of the item. “Green” means this item is normal; “Red” means it is out of range and a warning message will pop up at this time.

The screenshot shows the Winbond Hardware Doctor Ver 2.60 interface. It is divided into several sections: Voltage, Fan Speed, and Temperature. Each section contains a list of items with their current values, low and high limits, and a status indicator. A red oval highlights the status indicators for VcoreA, +3.3V, +5V, +12V, -12V, -5V, FAN1, and CPU1, all of which are green, indicating they are within normal ranges.

Item	Low Limit	High Limit	Current Value	Status
VcoreA	1.79	4.10	2.05	Green
VcoreB				
+3.3V	3.10	4.00	3.31	Green
+5V	4.49	6.00	5.11	Green
+12V	11.01	14.00	12.23	Green
-12V	13.01	-10.00	11.86	Green
-5V				
Vsb				
Vbat				
FAN1	1055		4.963	Green
FAN2				
FAN3				
CPU1	55.00	127	29.00	Green
Other				

Case Open:

If your PC case has a sensor for this functions , after marking this item , once the PC case is opened, the warning message will pop up and never disable unless you key in the correct password.

Exit:

Choosing the "X" button on the right corner of the tool bar in Hardware Doctor main menu, the menu will be minimized on the working bar of Windows 98 and serves as a TSR program. Only choosing the "exit" item under the " file" will exit Hardware Doctor.

Configuration Setting:

Press tool button and click configuration you can decide which item should be monitored or not.

User can decide the system to pop up the warning message when there is 1 fault detected or there are 3 consecutive faults detected.

In addition to pop up warning message, users can choose to activate a Beep tone if there is error detected. Beep tone will be continued until the error is treated.

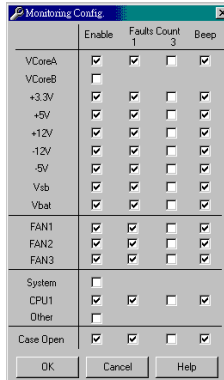

Fan Speed:

The most popular PC system may only have one fan on the motherboard. When the fan is not connected or doesn't exist, the fan speed column will be indicated "Low speed". At this time, please disable the fan in the "configuration" page.

CPU fan is located in the motherboard to keep CPU in normal temperature. If this fan turns low speed or stops, the temperature will be raised and the PC/CPU may be damaged or operate unstably.

Note: Only the fan with three output pins can be monitored!

Temperature:

All temperature-monitoring items only permit users to change the high limit, and the low limit will be set automatically as the high limit minus 5 degree C.

Once the CPU/System temperature over the high limit, the warning message will pop up and status will turn "Red". The status will not recover to be "Green" until the temperature gets lower than the high limit minus 5 degree C. Currently we have one thermostat on board for CPU temperature. You can use another thermostat connect to JP6 (two pins connector) as system temperature sensor.

Product Warranty/Service

ADLINK warrants that equipment furnished will be free from defects in material and workmanship for a period of one year from the date of shipment. During the warranty period, we shall, at our option, either repair or replace any product that proves to be defective under normal operation.

This warranty shall not apply to equipment that has been previously repaired or altered outside our plant in any way as to, in the judgment of the manufacturer, affect its reliability. Nor will it apply if the equipment has been used in a manner exceeding its specifications or if the serial number has been removed.

ADLINK does not assume any liability for consequential damages as a result from our product uses, and in any event our liability shall not exceed the original selling price of the equipment. The remedies provided herein are the customer's sole and exclusive remedies. In no event shall ADLINK be liable for direct, indirect, special or consequential damages whether based on contract of any other legal theory.

The equipment must be returned postage-prepaid. Package it securely and insure it. You will be charged for parts and labor if the warranty period is expired or the product is proves to be misuse, abuse or unauthorized repair or modification.