

ML610Q174 Reference Board User's Manual

Issue Date: Dec 5, 2013

NOTES

No copying or reproduction of this document, in part or in whole, is permitted without the consent of LAPIS Semiconductor Co., Ltd.

The content specified herein is subject to change for improvement without notice.

The content specified herein is for the purpose of introducing LAPIS Semiconductor 's products (hereinafter "Products"). If you wish to use any such Product, please be sure to refer to the specifications, which can be obtained from LAPIS Semiconductor upon request.

Examples of application circuits, circuit constants and any other information contained herein illustrate the standard usage and operations of the Products. The peripheral conditions must be taken into account when designing circuits for mass production.

Great care was taken in ensuring the accuracy of the information specified in this document. However, should you incur any damage arising from any inaccuracy or misprint of such information, LAPIS Semiconductor shall bear no responsibility for such damage.

The technical information specified herein is intended only to show the typical functions of and examples of application circuits for the Products. LAPIS Semiconductor does not grant you, explicitly or implicitly, any license to use or exercise intellectual property or other rights held by LAPIS Semiconductor and other parties. LAPIS Semiconductor shall bear no responsibility whatsoever for any dispute arising from the use of such technical information.

The Products specified in this document are intended to be used with general-use electronic equipment or devices (such as audio visual equipment, office-automation equipment, communication devices, electronic appliances and amusement devices).

The Products specified in this document are not designed to be radiation tolerant.

While LAPIS Semiconductor always makes efforts to enhance the quality and reliability of its Products, a Product may fail or malfunction for a variety of reasons.

Please be sure to implement in your equipment using the Products safety measures to guard against the possibility of physical injury, fire or any other damage caused in the event of the failure of any Product, such as derating, redundancy, fire control and fail-safe designs. LAPIS Semiconductor shall bear no responsibility whatsoever for your use of any Product outside of the prescribed scope or not in accordance with the instruction manual.

The Products are not designed or manufactured to be used with any equipment, device or system which requires an extremely high level of reliability the failure or malfunction of which may result in a direct threat to human life or create a risk of human injury (such as a medical instrument, transportation equipment, aerospace machinery, nuclear-reactor controller, fuel-controller or other safety device). LAPIS Semiconductor shall bear no responsibility in any way for use of any of the Products for the above special purposes. If a Product is intended to be used for any such special purpose, please contact a ROHM sales representative before purchasing.

If you intend to export or ship overseas any Product or technology specified herein that may be controlled under the Foreign Exchange and the Foreign Trade Law, you will be required to obtain a license or permit under the Law.

Copyright 2013 LAPIS Semiconductor Co., Ltd.

Preface

This manual describes the operation of the ReferenceBoard of the 8-bit microcontroller ML610Q174.

The following manuals are also available. Read them as necessary.

■ ML610Q174 User's Manual

Description on the operation of the hardware of the 8-bit microcontroller ML610Q174.

■ ML610Q172 / ML610Q173 User's Manual

Description on the operation of the hardware of the 8-bit microcontroller ML610Q172/ML610Q173.

■ uEASE User's Manual

Description on the on-chip debug tool uEASE.

1. Overview

1.1 Features

ML610Q174 Reference board is prepared by LAPIS SEMICONDUCTOR to have you study the operations of ML610Q174.

The board is arranged so that necessary components are mounted by you according to your purpose, then only minimum necessary components are mounted on the board by LAPIS SEMICONDUCTOR for brief use of ML610Q174.

By using the board with "uEASE on-chip debug emulator" (hereinafter referred to "uEASE") and "free sample U8 Development Tools CD-ROM" which is bundled in the package of uEASE not only Software development/debugging but also writing Flash ROM in the devices are capable.

This board also works in stand alone mode with external power supply without uEASE.

ML610Q172 and ML610Q173 exist as 64 pin versions of ML610Q174. Please use this board also for development and debugging of the software of ML610Q172. Please refer to "ML610Q172/ML610Q173 User's Manual" for the detail of ML610Q174 and ML610Q172/ML610Q173.

Before starting works with this board, read below carefully and understand notices.

The hardware specification of this board is shown below.

Embedded microcontroller	U1/U2(Mounting / IC-Socket): ML610Q174
Embedded parts	• UVDD、VSS: Input power supply pin
	• PWR: Jumper for input power supply switch (3pin pin-header and short pin)
	• CNUE: Connector for on-chip debug emulator (14pin connector)
	• XT_1/XT_2(Mounting / IC-Socket): 32.768kHz oscillator
	• OSC_1/OSC_2(Mounting / IC-Socket): 8MHz oscillator
	• P20-P23,P90-P91: Light emitting diodes
	• C1-C3/C10-C12(Mounting / IC-Socket): Capacitors for LCD external input voltage connection (3 pieces)
	• C4/C13(Mounting / IC-Socket): Capacitors for RESET_N pin.
	• C5/C14(Mounting / IC-Socket): Capacitors for VREF input voltage connection.
	• C6-C7/C15-C16: Capacitors for input voltage (2pieces)
	• C8-C9/C17-C18(Mounting / IC-Socket): Capacitors for 32.768kHz oscillator (2pieces)
Pads for mounting	• R1-R6: Resistance for light emitting diodes (P20-P23,P90-P91)
	• R7-R9/R10-R12(Mounting / IC-Socket): Resistance for LCD external input voltage connection (3 pieces)
	• SP1-SP6: Lands for light emitting diodes.
	• SP9-SP10(Mounting / IC-Socket): Lands for P10, P11 terminal connection
	• SP16/SP19(Mounting / IC-Socket): Pads for bonding of P85/VL2 and LCD external input voltage.
	• SP17/SP20(Mounting / IC-Socket): Pads for bonding of P84/VL1 and LCD external input voltage.
Other useful pads	• AIN0-AIN11: Land for SA-ADC terminal connection
	• CN1-CN4: Pads for peripheral board connectors (30pin×2、20pin×2、2.54mm pitch)
Operating voltage	• VDD = +2.2V to +5.5V、VREF = +4.5V to +5.5V
Board size	• 100.00 x 120.00 mm

This board is made on the assumption that it is used carrying in a user circuit. When used with this board simple substance, please use on an insulating material. An operation abnormality may be caused when used on a conductive material.

ML610Q174 of the engineering sample may be carried in this board. Please confirm the final confirmation of an electrical property etc. on mass production goods and customer's production board. The support about this board is not accepted. Only in the case of initial failure, exchange responds.

1.2 The external view of a board

The external view of ML610Q174 ReferenceBoard is shown.

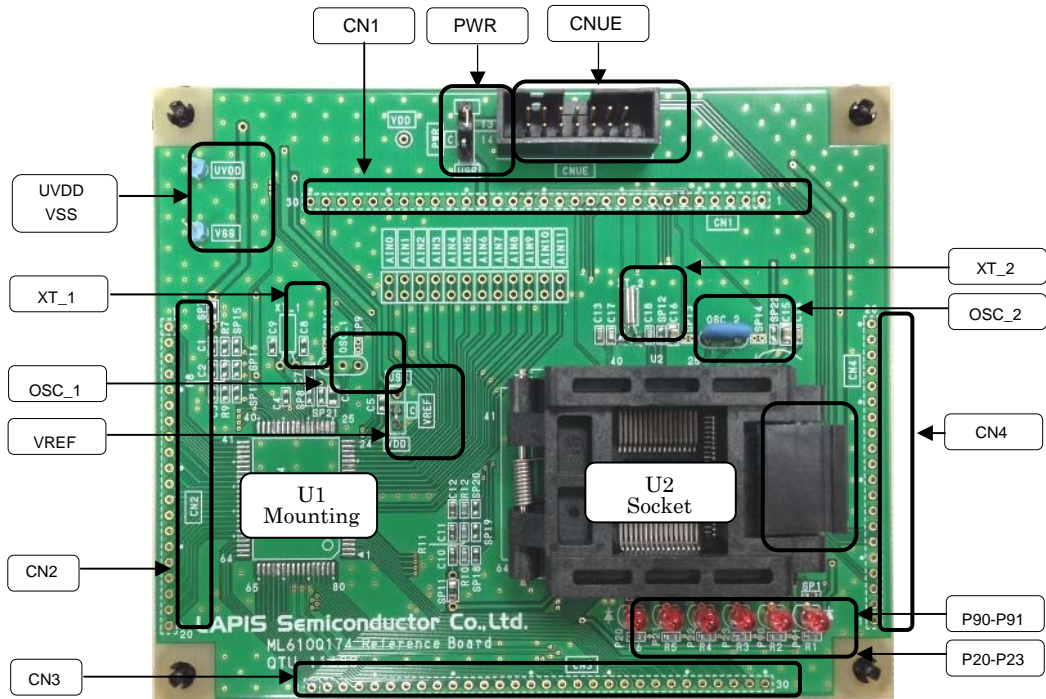

Fig.1. ML610Q174 ReferenceBoard External view

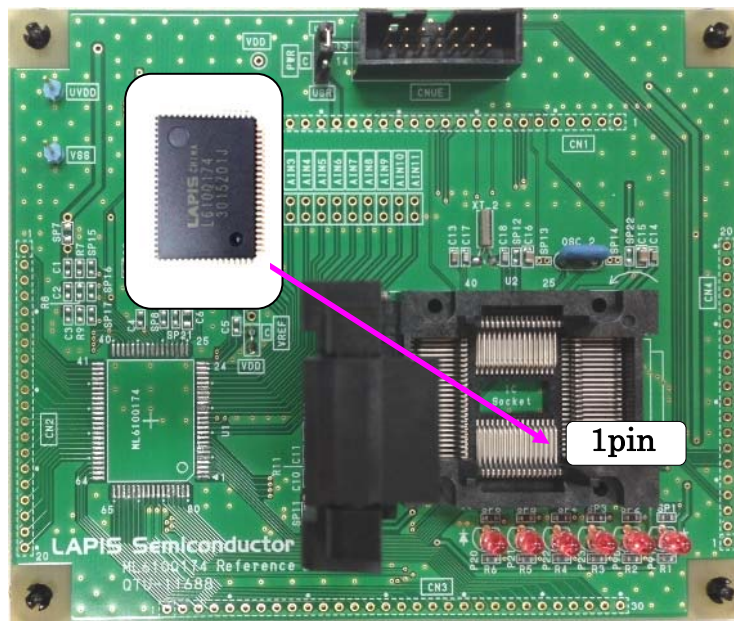

Fig.2. Direction of device set

When a device is set to a reference board, please carry out, where the power is turned off. Moreover, please set not to mistake the direction of a device.

2. Function

2.1 PWR Jumper

It is a jumper which selects the power source of this board. When supplying voltage from uEASE, set a PWR jumper to the "uE" side.

The ability to supply power of the uEASE is +3.3v/100mA.

When a power supply is inputted from the external, please input between check pin UVDD-VSS and set a PWR jumper to the "USR" side.

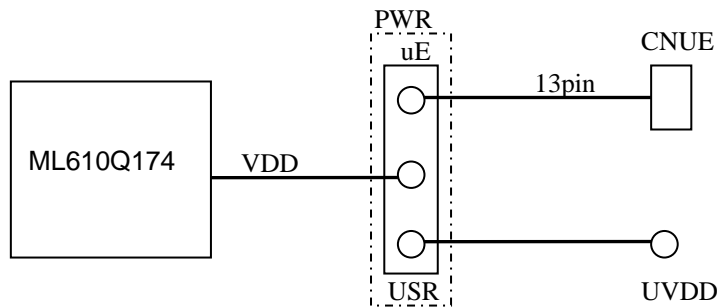

Fig.3. PWR Jumper

Note:

Where the PWR jumper is set to the "USR" side, when uEASE is connected, please turn ON the power supply of a user application system after connecting uEASE. Moreover, please remove uEASE after turning OFF the power supply of a user application system.

2.2 The case of using successive approximation ADC

When a conversion target is inputted into AIN0-AIN11, without going via CN1/CN4, Please cut the pattern of AIN0-AIN11 if needed and input from the hole near a device.

The example of processing is shown below.

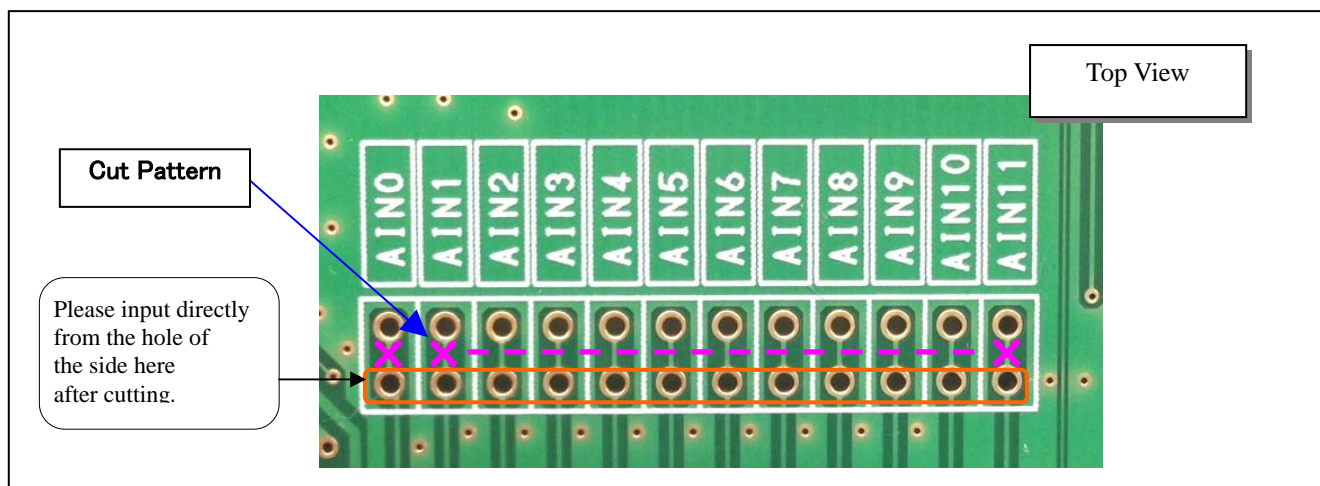

Fig.4. AIN0-AIN15 (SA-ADC)

VREF is connected with VDD by the jumper at the time of shipment. When you input arbitrary voltage, please change a VREF jumper to the USER side and input VREF voltage from 1_CN6 pin (VREF).

The example of processing is shown below.

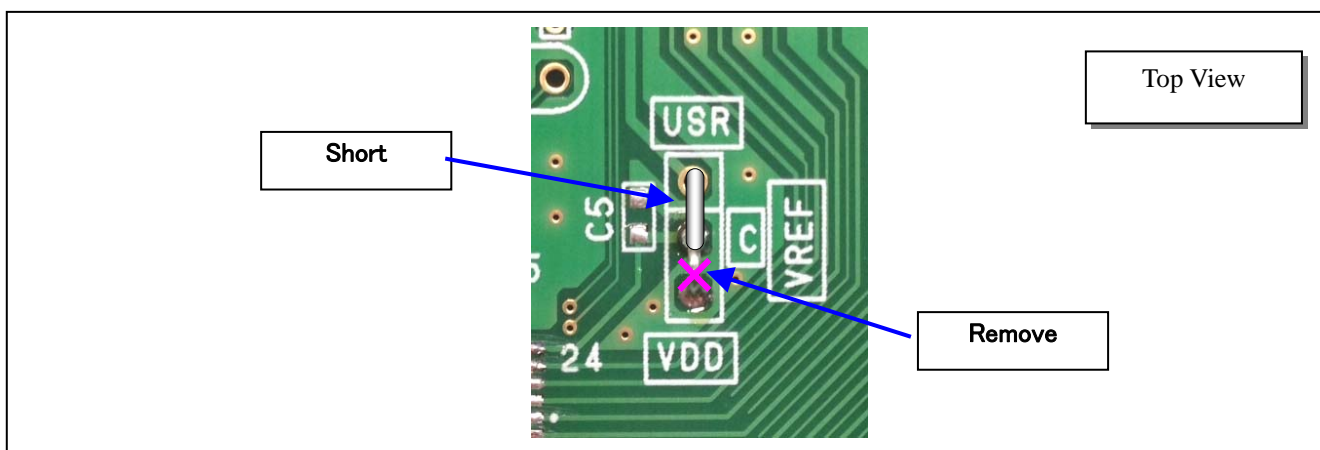

Fig.5. VREF(SA-ADC)

2.3 The case of using light emitting diodes

P20-P23, P90-P91 can drive direct to light emitting diodes. P20-P23, P90-P91 are wired with light emitting diodes on this board. Please remove the parts mounted in SP1-SP6. The example of processing is shown below.

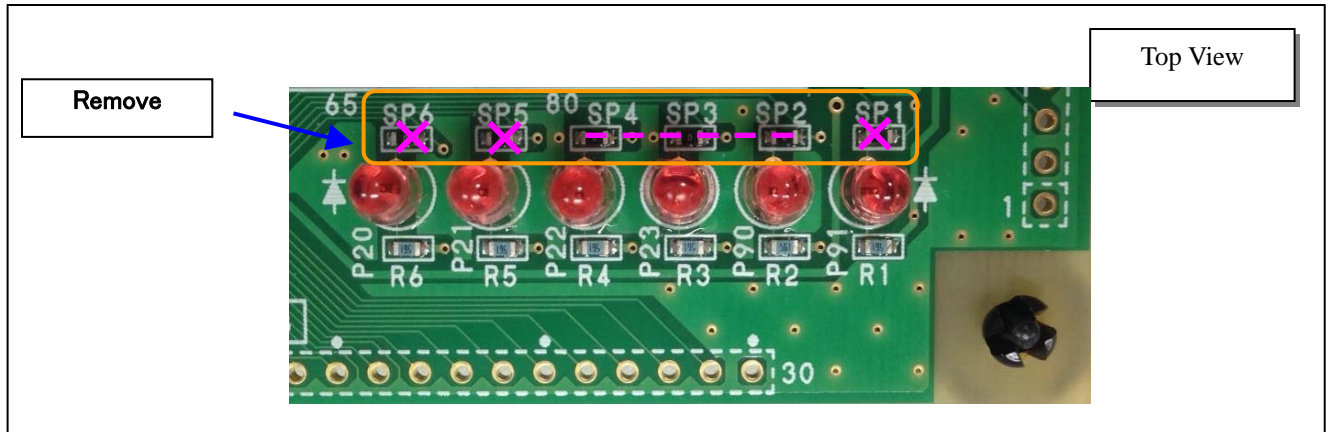

Fig.6. SP1-SP5 pads

2.4 The case of driving LCDs

The chip resistor of 2012 sizes can be mounted between VL3 to VDD (SP7/SP11 pad). At the time of shipment, since VDD and VL3 short-circuit, please mount a chip resistor in SP7/SP11 if needed. Please refer to figure 6.(VL3) The example of processing is shown below.

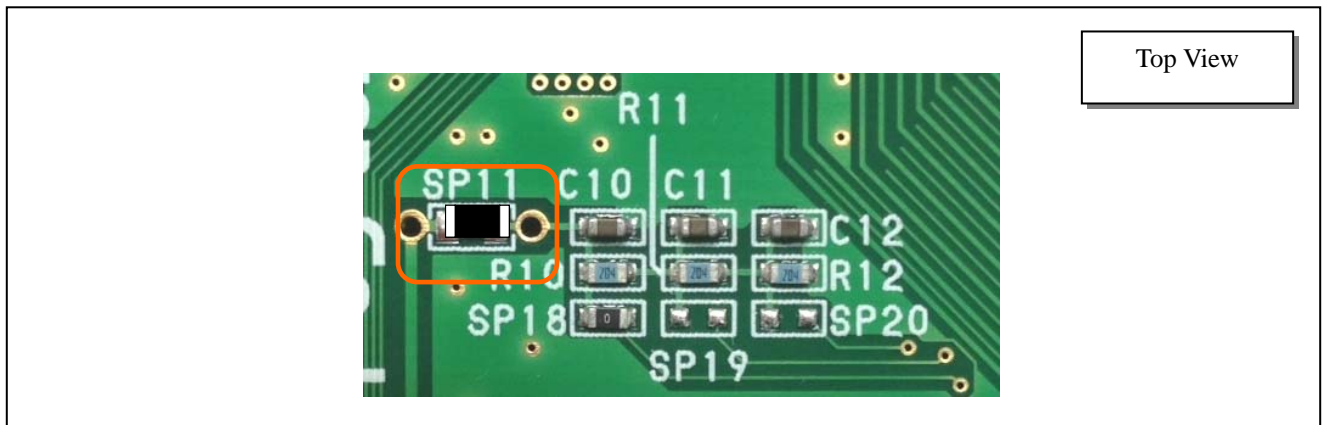

Fig.7. SP7/SP11 pads

Note:

It is a short condition between VL3 and LCD driving voltage input pin (SP15/SP18). Moreover, it is an open condition between P85/VL2 and an LCD driving voltage input pin (SP16/SP19 pad) and between P85/VL2 and LCD driving voltage input pin (SP17/SP20).

As for the method of using VL3, P85/VL2 and P84/VL1 as LCD driving power sources, the following three kinds of methods exist.

- The LCD external input voltage on a reference board is used.
- Voltage is inputted from CN1_24 to 26.
- Voltage is generated using a built-in LCD resistance.

Please be careful for the LCD external input voltage on a reference board, the voltage inputted from CN1_24~26, and the voltage generated inside LSI not to short-circuit.

2.5 P10-P11 is used as general purpose input ports

P10-P11 can change and use a 8MHz oscillation terminal and a general input port terminal. When you use it as a general input port terminal, please remove an 8MHz oscillator and short-circuit SP9/SP10 and SP13/SP14, respectively. Please refer to figure 7. (P10,P11 8MHz oscillator)
The example of processing is shown below.

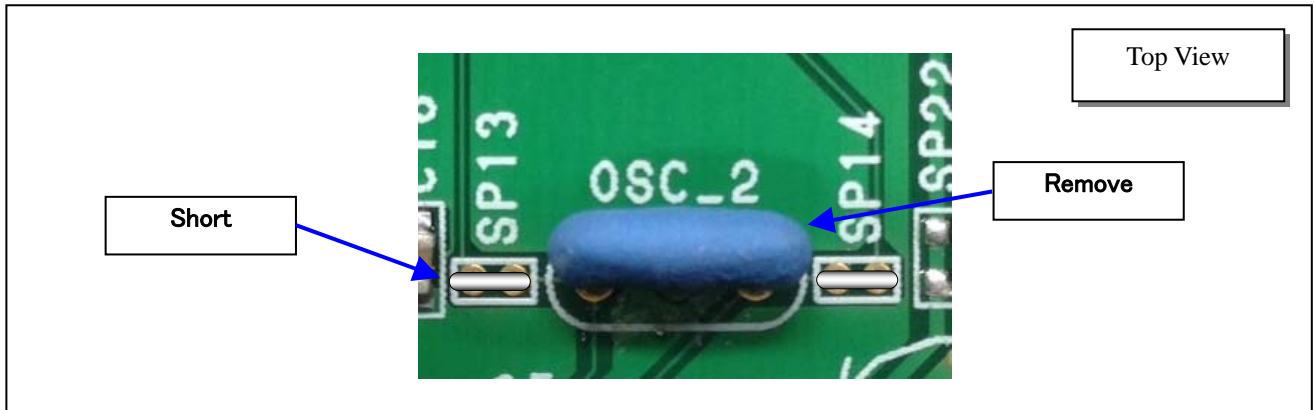

Fig.7. SP9/SP10、SP13/SP14 pads

3. User interface

3.1 The user interface of ML610Q174 Reference Board

The pin assignment of CN1, CN2, CN3 and CN4 of the reference board embedded ML610Q174 in below is shown.

Table 1. ML610Q174 Reference Board CN1 / CN2

CN1	Name	LSI Pin No.
1	P44/TOP4CK/AIN4/SIN0	19
2	P33/AIN3	20
3	P32/AIN2	21
4	P31/PW6EV1/AIN1	22
5	P30/PW45EV1/AIN0	23
6	VREF	24
7	P50/AIN8/SIN1	15
8	P51/AIN9/SCK1	14
9	P52/CMP0P/RXD1/SOUT1	13
10	P53/CMP1P/TXD1/PWM6/TXD0	12
11	P34/AIN11/PWM4	10
12	P35/AIN10/PWM5	11
13	P36/LSCLK	33
14	NC	---
15	NC	---
16	P10/OSC0	25
17	P11/OSC1	26
18	VSS	27
19	UVDD	28
20	NC	---
21	NC	---
22	NC	---
23	NC	---
24	VL3	34
25	P85/VL2	35
26	P84/VL1	36
27	P83/COM3	37
28	P82/COM2	38
29	P81/COM1	39
30	P80/COM0	40

CN2	Name	LSI Pin No.
1	SEG0	41
2	SEG1	42
3	SEG2	43
4	SEG3	44
5	SEG4	45
6	SEG5	46
7	SEG6	47
8	SEG7	48
9	PC0/SEG8	49
10	PC1/SEG9	50
11	PC2/SEG10	51
12	PC3/SEG11	52
13	PC4/SEG12	53
14	PC5/SEG13	54
15	PC6/SEG14	55
16	PC7/SEG15	56
17	PD0/SEG16	57
18	PD1/SEG17	58
19	PD2/SEG18	59
20	PD3/SEG19	60

Table 2. ML610Q174 Reference Board CN3 / CN4

CN3	Name	LSI Pin No.
1	PD4/SEG20	61
2	PD5/SEG21	62
3	PD6/SEG22	63
4	PD7/SEG23	64
5	NC	---
6	NC	---
7	NC	---
8	NC	---
9	NC	---
10	NC	---
11	NC	---
12	NC	---
13	PF0/SEG32/SIN0	65
14	PF1/SEG33/SCK0	66
15	PF2/SEG34/RXD0/SOUT0	67
16	PF3/SEG35/TXD0/PWM4/TXD1	68
17	PF4/SEG36/SIN1/PWM4	69
18	PF5/SEG37/SCK1/PWM5	70
19	PF6/SEG38/RXD1/SOUT1/PWM6	71
20	PF7/SEG39/TXD1/TXD0	72
21	RESET_N	32
22	P40/SDA/SIN0	6
23	P41/SCL/SCK0	7
24	P42/RXD0/SOUT0	8
25	P43/TXD0/PWM4/TXD1	9
26	P00/EXI0/PW45EV0	75
27	P01/EXI1/PW6EV0	76
28	P02/EXI2/RXD0	77
29	P03/EXI3/RXD1	78
30	NC	---

CN4	Name	LSI Pin No.
1	P20/LED0/LSCLK/PWM4	79
2	P21/LED1/OUTCLK/PWM5	80
3	P22/LED2/TM9OUT	2
4	P23/LED3/TMBOUT	3
5	VSS	1
6	P90/LED4	4
7	P91/LCD5	5
8	NC	---
9	NC	---
10	NC	---
11	NC	---
12	NC	---
13	NC	---
14	NC	---
15	NC	---
16	NC	---
17	NC	---
18	P47/T9BCK/AIN7/CMP1M	16
19	P46/T8AP6CK/AIN6/CMP0M	17
20	P45/T1P5CK/AIN5	18

4. The circuit diagram and substrate dimensional drawing

The circuit diagram and substrate dimensional drawing of this board are shown after a next page.

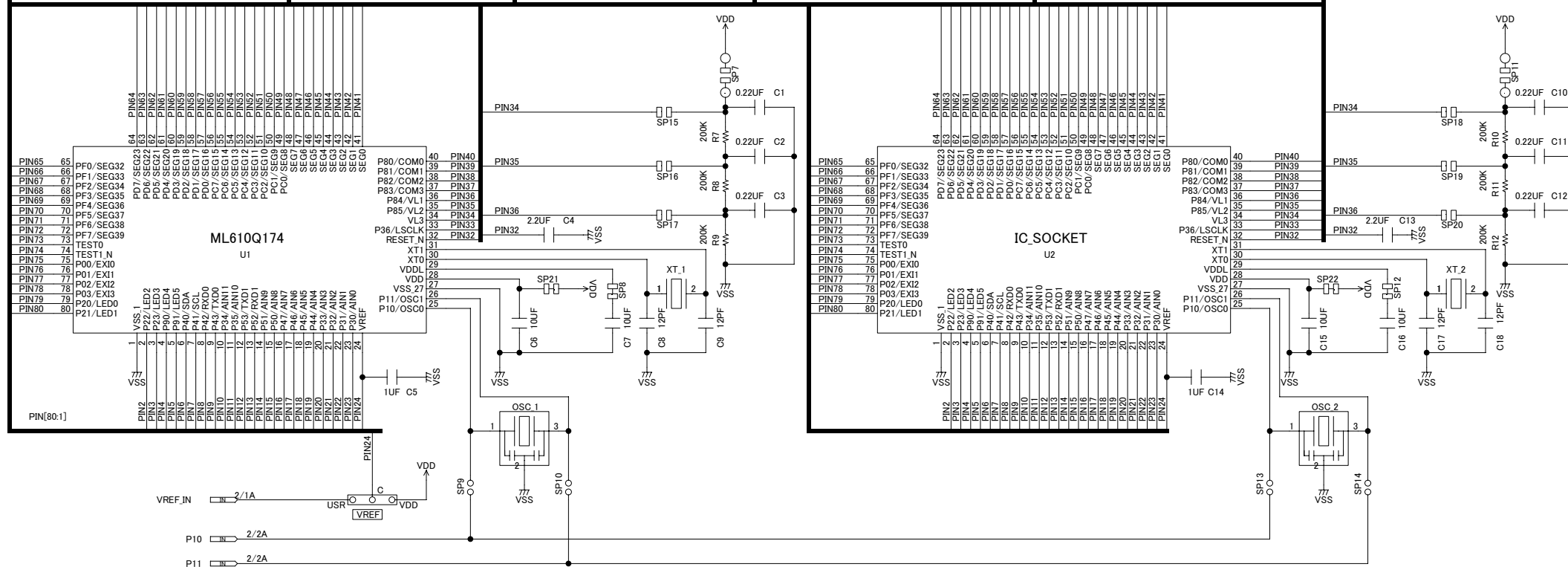
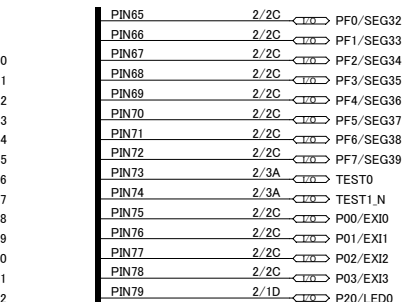
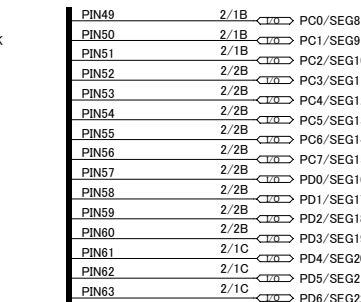
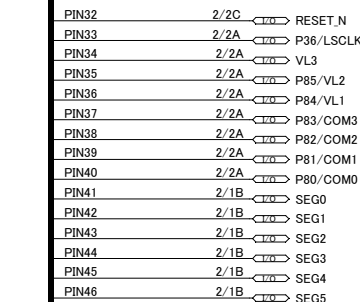
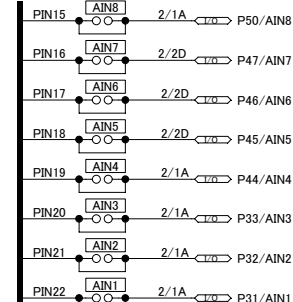
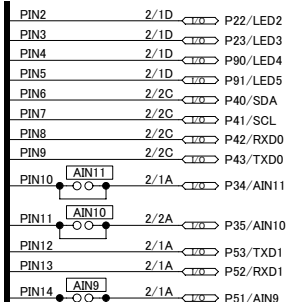
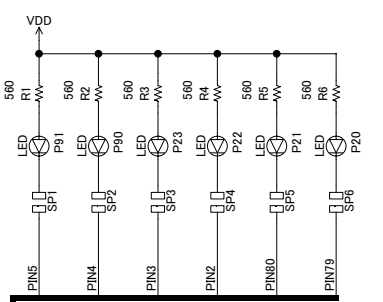

LAPIS Semiconductor Co., Ltd.	
TITLE	ML610Q174 Reference Board
APPLICATION	ML610Q174
DWG NO	QTS-11583
DRAWN By	SHEET 1 of 2
SHEET	REV 1.00

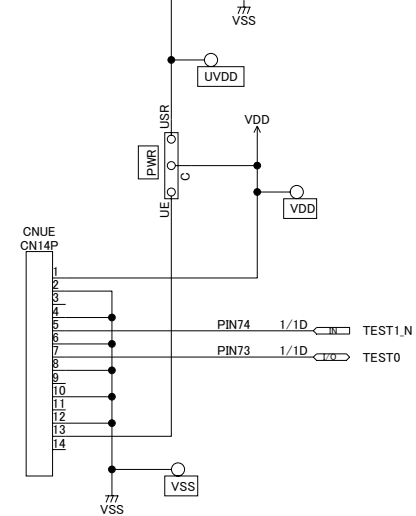
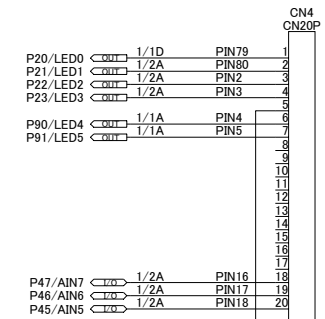
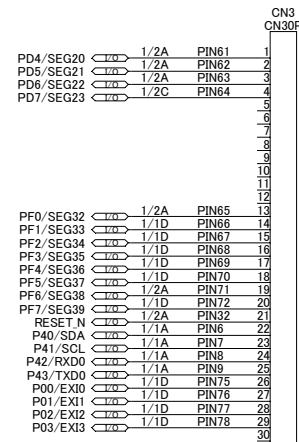
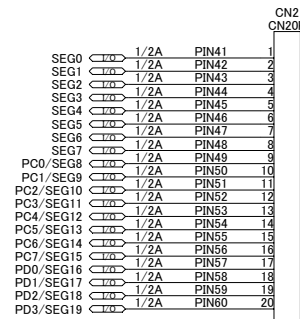
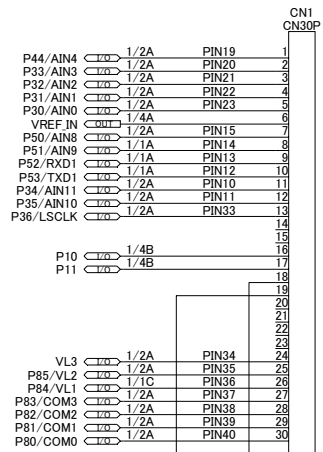

LAPIS Semiconductor Co., Ltd.		
TITLE	ML610Q174 Reference Board	
APPLICATION	ML610Q174	
DWG NO	QTS-11583	
DRAWN By	SHEET	2 of 2
		REV 1.00

