

DIN-RS232

user's guide

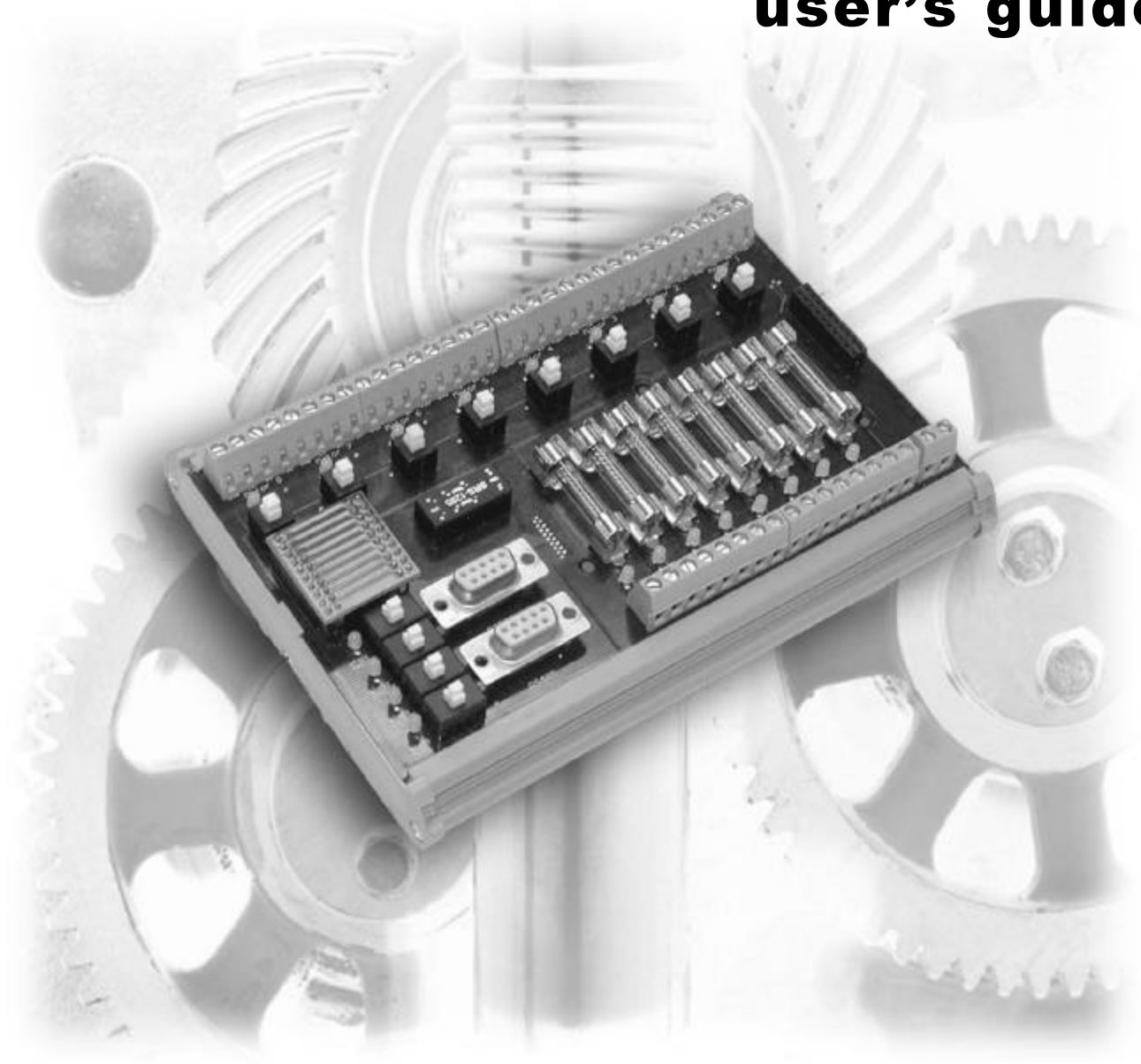

ANIMATICS®

Defining the Future in Motion Control

Overview

The DIN-RS232 is a DIN rail mount breakout for SmartMotor™ RS-232 communications. It allows a single master to communicate with up to eight SmartMotors over RS-232 without the loss of bandwidth typical of daisy chain propagation. Since this operation is nearly identical to the operation of a RS-485 bus, the DIN-RS232 can also accommodate an RS-485 master. Hereafter, the SmartMotor™ version 3 and 4 products will simply be referred to as the SmartMotor™. The DIN-RS232 provides an interface between either an RS-232 or RS-485 host and up to eight SmartMotors via an opto-isolated parallel bus. The connection to the SmartMotors is not in daisy chain, eliminating long propagation timing delays. The DIN-RS232 also provides a fused power distribution bus and the Animatics peripheral expansion bus.

The DIN-RS232 has three primary functions:

- Isolated parallel RS-232 interface
- Fused power distribution
- Animatics peripheral expansion bus

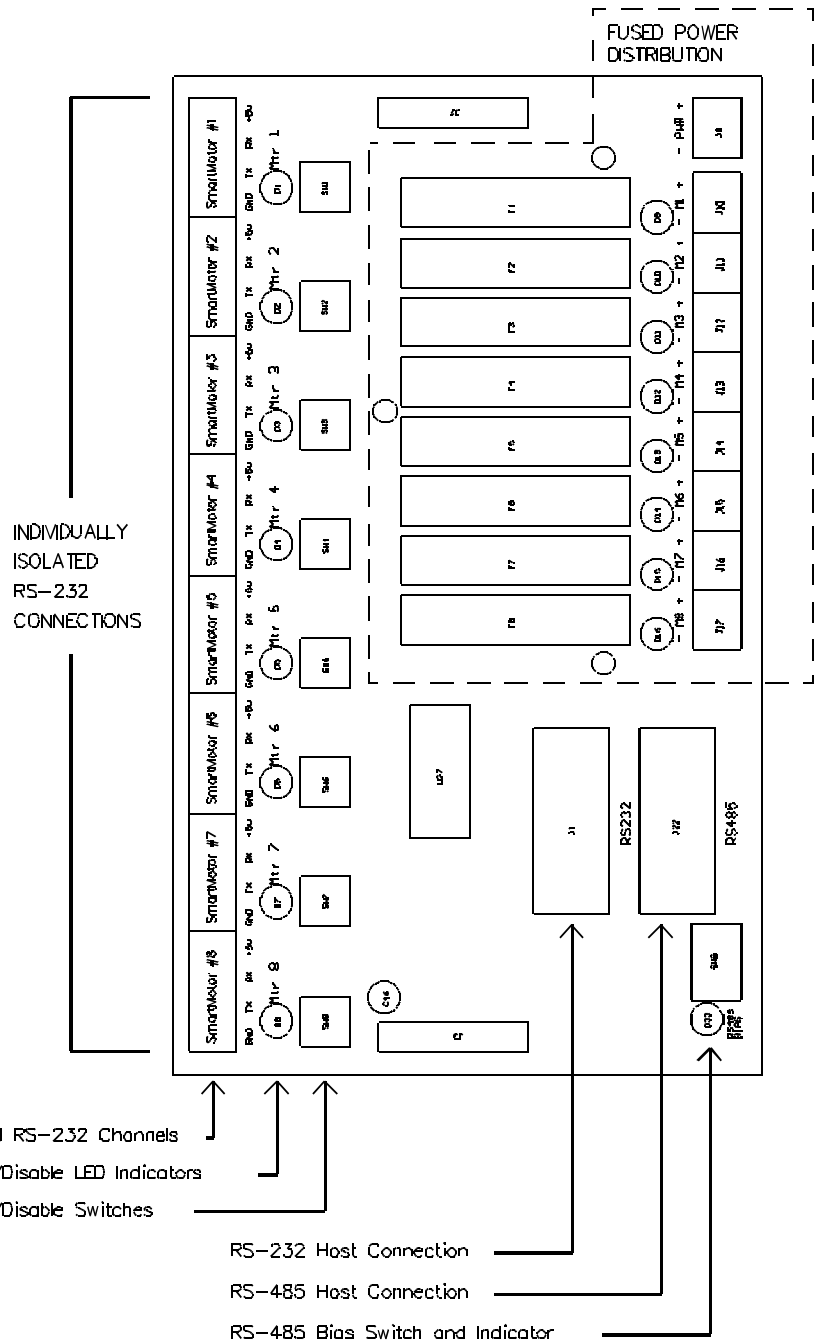

If one DIN-RS232 is used, the RS485 bias switch has to be enabled for RS232 or RS485 communication. If more than one DIN-RS232 is used, only one of the DIN-RS232 needs to have the RS485 bias switch enabled.

Absolute maximum ratings are levels beyond which damage may occur. The ratings for the DIN-RS232 are given below.

Absolute maximum fused power bus voltage:	48VDC
Absolute maximum fused power bus current:	20A RMS
Absolute maximum +5VC to any motor port:	+5.5VDC
Absolute minimum +5VC to any motor port:	-0.3VDC
Absolute maximum RS-232 input voltage:	-20VDC
Recommended +5VC motor port voltage:	5 -0.25 VDC
Typical +5VC motor port operating current:	35 mA DC

Isolated Parallel RS-232 Interface

The DIN-RS232 provides an interface between either a RS-232 or RS-485 host and up to eight SmartMotors. More SmartMotors can be hooked up by adding more DIN-RS232 units. The connection to the host is through one of two connectors, one for RS-232 and one for RS-485. While the RS-485 and RS-232 circuits share the same signal ground, they are optically isolated both from the eight SmartMotor™ serial channels and power distribution circuitry.

The RS-232 interface uses a standard three wire hookup for a nine pin D-subminiature connector. It is pinned for a standard 9 pin male-female RS-232 cable, not a null modem cable.

Unlisted pins have no connection.

The RS-485 interface is set to be a slave by default. This means that the interface is always “listening” if nothing is being transmitted from a SmartMotor. In other words, the lines are floating inputs. You may notice a pushbutton switch and LED next to the RS-485 connector. If this button is pressed, the LED will either light or go dark. If the LED is lit green, the RS-485 is biased with with on-board pull-up, pull-down and terminating resistors as shown in the schematic.

Unlisted pins have no connection.

The RS-485 interface is set to be a slave by default. This means that the interface is always “listening” if nothing is being transmitted from a SmartMotor. In other words, the lines are floating inputs. You may notice a pushbutton switch and LED next to the RS-485 connector. If this button is pressed, the LED will either light or go dark. If the LED is lit green, the RS-485 is biased with with on-board pull-up, pull-down and terminating resistors as shown in the schematic.

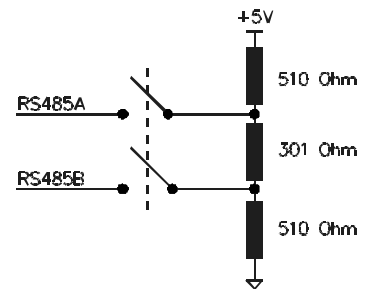
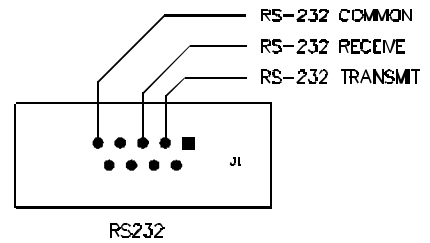

Due to the nature of RS-485, the biasing resistors, or their equivalent, must exist somewhere in a RS-485 communication bus.

Due to the nature of RS-485, the biasing resistors, or their equivalent, must exist somewhere in a RS-485 communication bus. The terminator is required in particularly noisy environments or high baud rates. If these resistors are absent, intermittent or continuous communication errors may result. In many cases, RS-485 transceivers that are designed as masters, or hosts, already incorporate this biasing, but not the terminating resistor.

The RS-485 interface is also a three pin hookup in a D-subminiature connector. As there is no generally accepted standard for RS-485 in a 9 pin D-sub, the pins were selected to avoid accidental damage in the case the RS-232 plug is inserted into the RS-485 connector, or vice-versa.

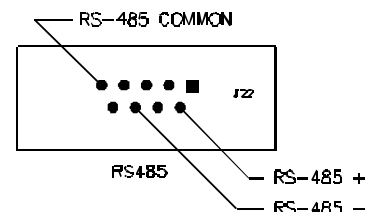

The RS-232 and RS-485 host interfaces are connected in parallel with each other and all of the SmartMotors. A block diagram of this communications function of the unit is given below:

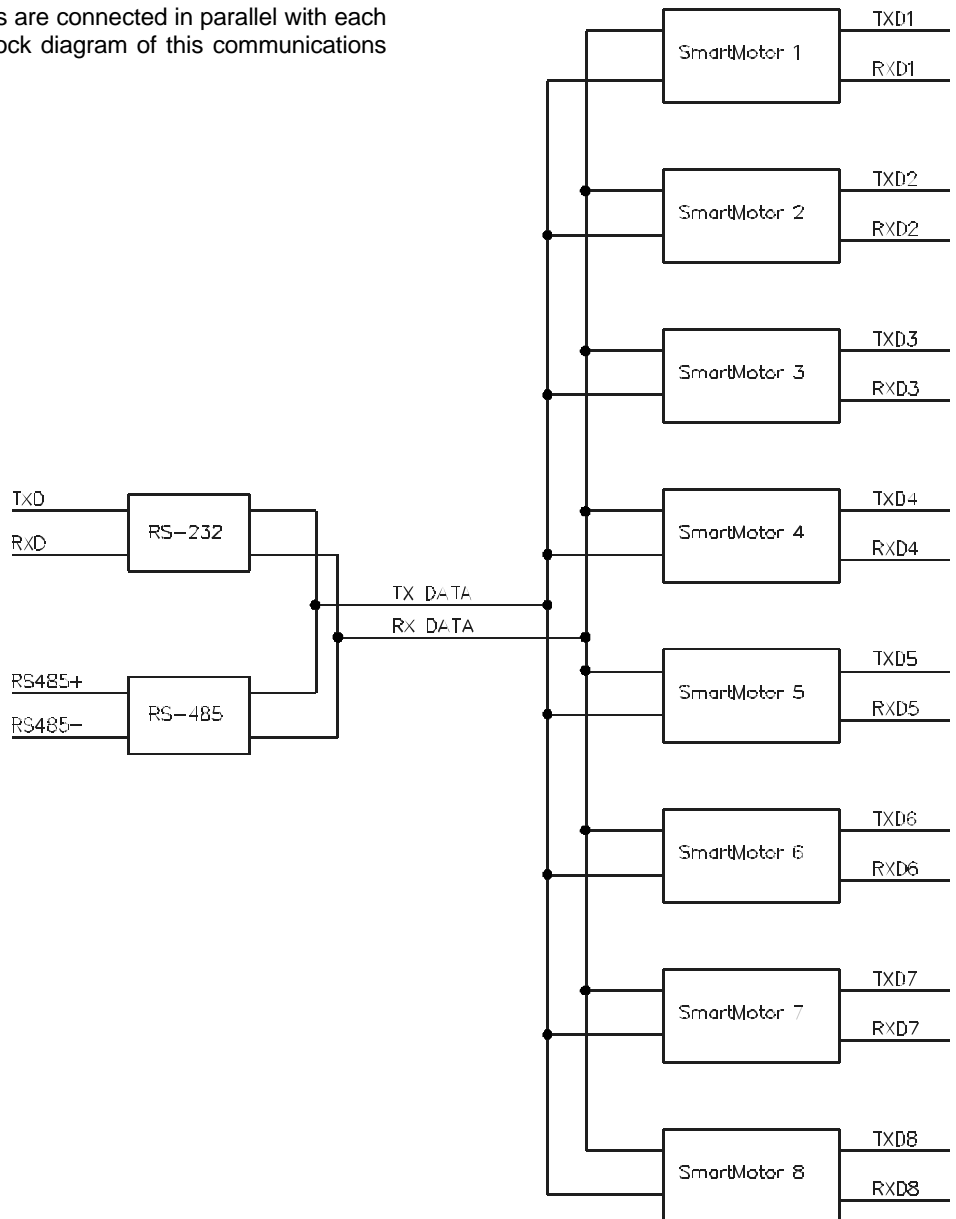

There are two very important things to note and keep in mind when using the DIN-RS232. The first is that all of the SmartMotors are effectively connected in parallel. In the typical RS-232 system, each node is connected in a series daisy chain, where each node passes information sequentially down the chain. Each node takes a finite amount of time to receive and re-transmit the message it receives, resulting in a total system propagation delay that grows with each node that you add to the chain. If the nodes are in parallel, as in the case of the DIN-RS232, the time delay is minimized and is independent of the number of SmartMotors used. Nothing is for free, however, as this means that you have to ensure that no SmartMotor™ is talking at the same time as another.

The second thing to note is that, while both the host RS-232 and RS-485 channels can fully communicate with the SmartMotors, neither channel can communicate with or monitor the other. Both host channels, however, always “see” what the SmartMotors are transmitting. The SmartMotors connect to the DIN-RS232 via standard pitch terminal blocks. These are optically isolated from both the host serial channels and power distribution circuitry. Each set of terminal blocks is connected as follows.

All of the SmartMotors are effectively connected in parallel

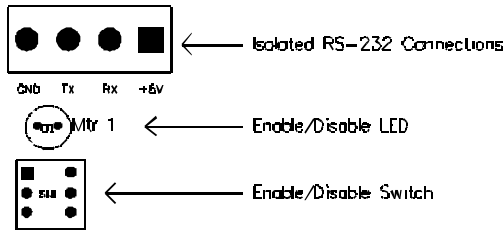

You must connect all four of these signals to the SmartMotor™ in order for the communications to operate properly. Each SmartMotor™ interface is equipped with a disable switch. If the LED just above this switch is red, the SmartMotor™ is powering the interface circuit, but communication both into and out of the SmartMotor™ is disabled. If the LED is green, communications is enabled. If the LED is dark, the interface is not getting power.

Each SmartMotor™ interface is equipped with a disable switch. If the LED just above this switch is red, the SmartMotor™ is powering the interface circuit, but communication both into and out of the SmartMotor™ is disabled. If the LED is green, communications is enabled. If the LED is dark, the interface is not getting power.

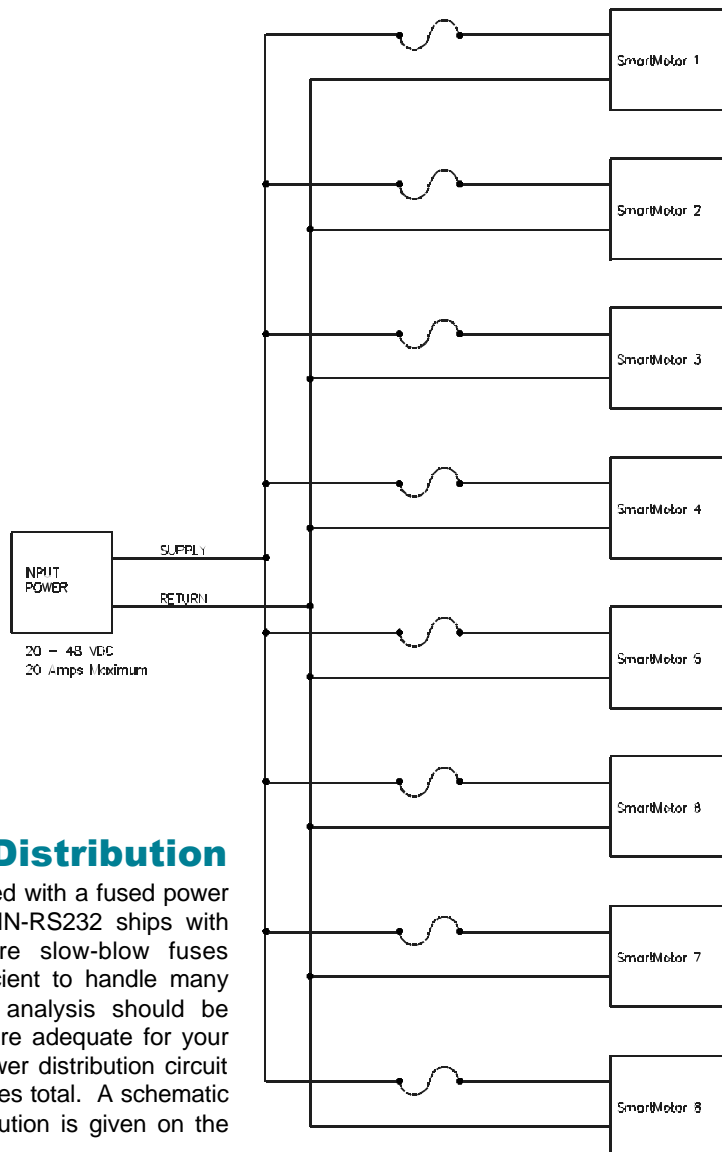

Fused Power Distribution

The DIN-RS232 is equipped with a fused power distribution circuit. The DIN-RS232 ships with eight 250VAC, 8 ampere slow-blow fuses installed. These are sufficient to handle many applications, but careful analysis should be made to verify that they are adequate for your application. The fused power distribution circuit is rated for 20 RMS amperes total. A schematic of the fused power distribution is given on the right .

The fused power distribution circuit is rated for 20 RMS amperes total.

Animatics Peripheral Expansion Bus

The expansion bus does not directly connect to any circuitry on the DIN-RS232. The Animatics Expansion Bus provides a convenient way to connect several SmartMotors and their DIN-rail mount expansion modules without using any additional cable. Every Animators DIN-rail mount expansion module has two expansion bus connectors for receiving signals from modules on either end of it. The bus passes through the module without any direct connection to any SmartMotor™ I/O or expansion module function. To make use of the bus, it has to be connected to some SmartMotor™ I/O or expansion bus card through the jumpers.

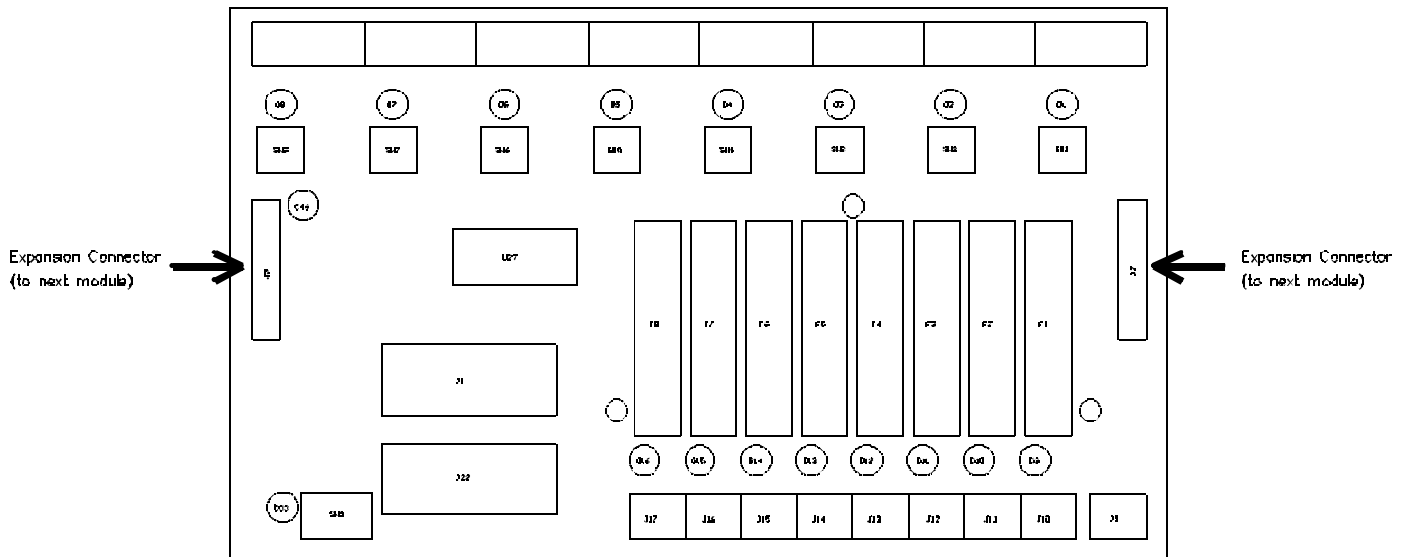

Its primary purpose is to pass signals from other modules through, if necessary.

Application

The diagram below shows a typical connection between a PLC to three SmartMotors.

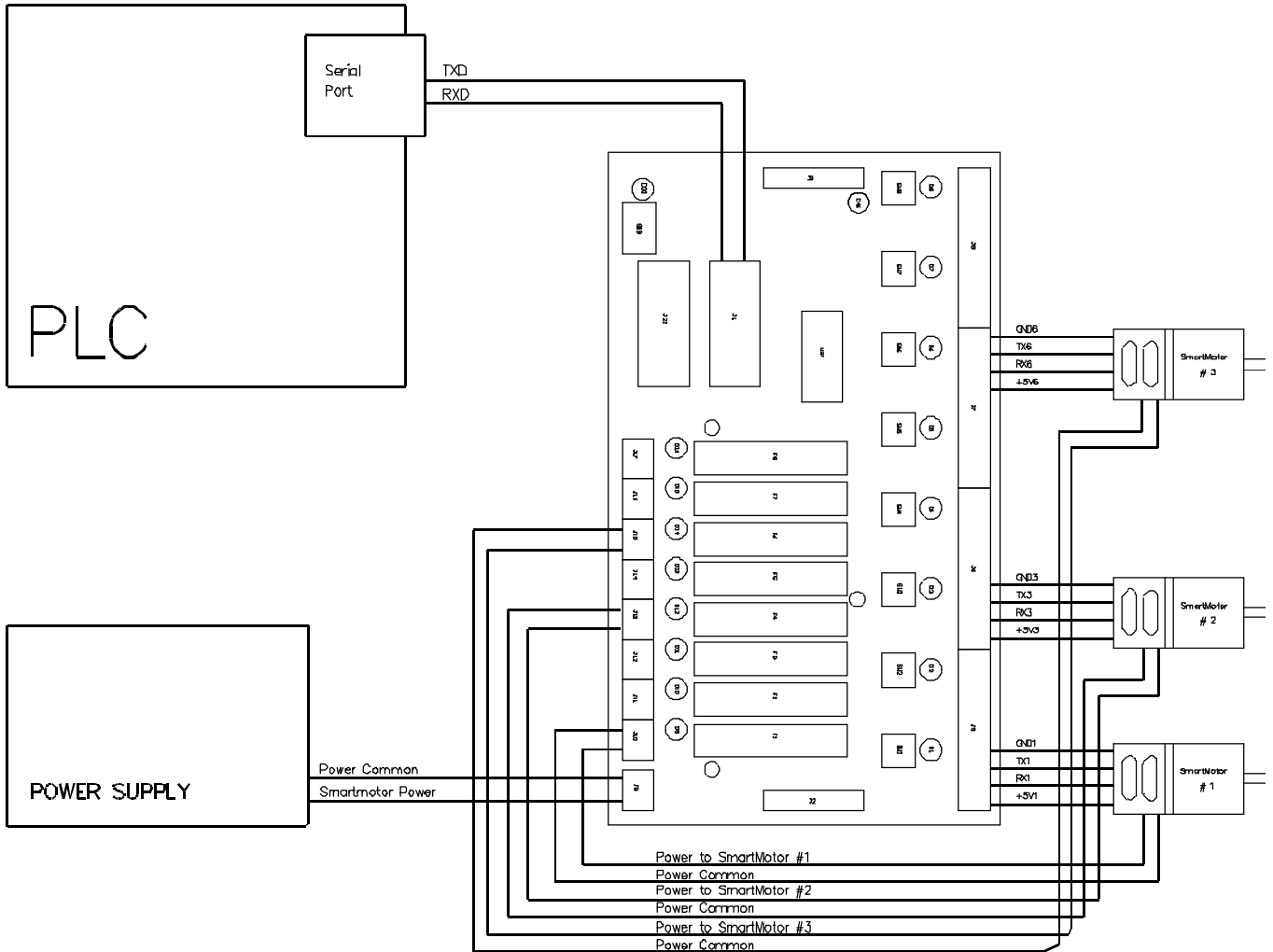

The commands you would use to communicate with the SmartMotor™ are the same ones you would normally use. From the SMI terminal screen, the command

2RP

still causes SmartMotor™ #2 to report its position back to the host.

Care is needed to ensure that none of the SmartMotors transmit at the same time. You would not, for example, ever issue "ORP" from the SMI terminal, as this would tell all the SmartMotors to report their positions at the same time. The result would be a tangle of bus collisions and unintelligible data.

If you are using the RS-485 port, the SMI terminal needs to be set up appropriately. To do this, click on Setup on the menu bar, followed by Configure Host Port. A dialog box entitled "Set Host Communications Port" will pop-up. Near the upper right corner of the dialog box, click on the radio button labeled "RS-485." Close the dialog box by clicking the "OK" button. This procedure sets up SMI to not expect any character echoes in all functions, such as terminal communications and user program download.

Care is needed to ensure that none of the SmartMotors transmit at the same time.

It is important to note that the parallel nature of the DIN-RS232 requires that the SmartMotors be addressed individually. This is easily done with the enable/disable switches at each of the SmartMotor™ interfaces by the following procedure:

- Disable all of the SmartMotor™ channels – all of the LEDs should be red or dark.
- Enable the channel of the SmartMotor™ you wish to address. The LED on that channel should be green.
- Set the address – this is typically done with the ADDR# or ADDR= commands, downloading a program that contains the address, or writing to the data EEPROM that is read by the user program.
- Repeat the above until all addresses are set.

Storing the address in the data EEPROM is possible only in SmartMotor™ versions 4.15, 4.41, 4.75 and later. An example of a user code fragment that does this is given below:

```
EPTR=12      `Set the data EEPROM pointer to 12
              `There is nothing special about the number 12
              `It is just a location in the data EEPROM
VLD(aaa,1)   `Load a single 32 bit value from the EEPROM
              `into the variable aaa.
ADDR=aaa     `Assign the value of aaa to be the
              SmartMotor's address.
```

This program needs to be in each SmartMotor™ user program. After loading the program into each, you would have to put the correct address value into the data EEPROM at location 12 of each SmartMotor. You would do this by the following command sequence:

```
EPTR=12
aaa=1
VST(aaa,1)
```

Note that the command “aaa=1” sets the address of the motor to be 1. If you wanted it to be 5, you would have typed “aaa=5” instead.

For further details about the serial communications command and protocol statements, please refer to the SmartMotor™ Users Guide.