

# 6820E/6821E Series

## FIBER OPTIC FAST ETHERNET SWITCHING CONVERTER



BCI reserves the right to make changes to the products described herein without prior notice or consent. No liability is assumed as a result of their use or application. All rights reserved.

©2005 Broaddata Communications, Inc.



## **SAFETY INSTRUCTIONS AND COMPLIANCE DECLARATIONS**

PLEASE OBSERVE THE FOLLOWING SAFETY  
PRECAUTIONS AS OUR PRODUCTS CONTAIN

### **CLASS I LASER PRODUCTS**

#### **WARNING**

Do not disconnect the fiber optic connector while the unit is powered up. Exposure to laser radiation is possible when the laser fiber optic connector is disconnected while the unit is powered up.

Although the fiber optic connectors in this product emit only Class 1 energy that is below the levels considered to be hazardous, one should never stare directly into a fiber optic connector or an unconnected fiber end unless one can be certain that no exposure to laser energy could occur.



This manual is intended for use by trained service personnel. The use of controls, making adjustments, or performing operations other than those specified may result in hazardous radiation exposure.

The following label or equivalent is located on the surface of laser products. This label indicates that the product is classified as a CLASS 1 LASER PRODUCT.



#### **SURGE PROTECTION DEVICE RECOMMENDED**

This product contains sensitive electrical components that may be damaged by electrical spikes, surges, electric shock, lightning strikes, etc. Use of surge protection systems is highly recommended in order to protect and extend the life of your equipment.

## TABLE OF CONTENTS

<b>1.0</b>	<b>PRODUCT DESCRIPTION .....</b>	<b>5</b>
<b>2.0</b>	<b>SETUP .....</b>	<b>6</b>
<b>3.0</b>	<b>LED DESCRIPTION .....</b>	<b>7</b>
<b>4.0</b>	<b>SPECIFICATIONS .....</b>	<b>8</b>
<b>5.0</b>	<b>REAR PANEL DIP SWITCH .....</b>	<b>8</b>
<b>6.0</b>	<b>FIBER LINK ALARM .....</b>	<b>9</b>
<b>7.0</b>	<b>SERVICE PROCEDURE .....</b>	<b>10</b>
<b>7.1</b>	<b>REPLACEMENT POLICY .....</b>	<b>10</b>
<b>7.2</b>	<b>RETURN AND REPAIR SERVICE .....</b>	<b>10</b>
<b>8.0</b>	<b>LIMITED WARRANTY .....</b>	<b>11</b>

## 1.0 PRODUCT DESCRIPTION

BCI's 6820E/6821E Series is designed to meet the needs for massive optical fiber network deployment and able to extend a legacy copper based network via fiber cable to a maximum distance of up to 100KM.

The 6820E/6821E is fully compliant with IEEE 802.3 & 802.3u standards; built-in switching ASIC has turned 6820E/6821E function more like a 2 port switch rather than a traditional converter. The user can get all of the switching benefits such as traffic segmentation, frames checking and error filtering. In addition, Fiber Link Alarm allows the user to monitor and maintain their critical fiber link more easily and effectively.

The installation and operation procedures of the 6820E/6821E are simple and straightforward. Operation status can be monitored through a set of diagnostic LED located in the front panel (as shown in Figure 1-1).

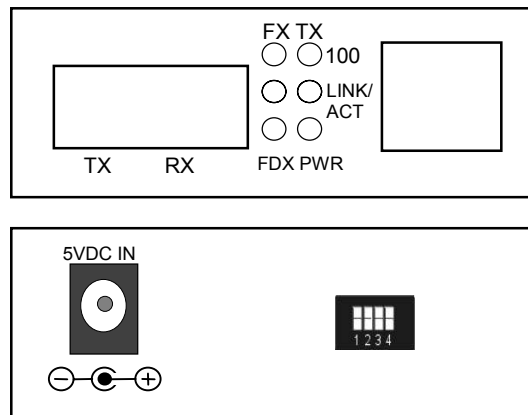
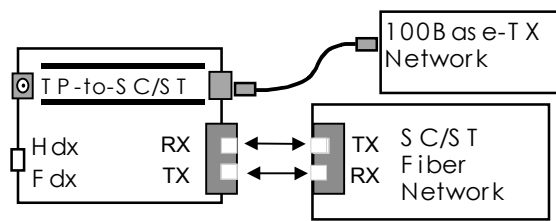

**Figure 1-1**  
**6820E/6821E Front/Rear Panels**

## 2.0 SETUP

The installation procedure is simple and straightforward.

- Attach fiber cable from the 6820E/6821E to the fiber network.
- Attach UTP cable from the 10/100Base-TX network to the RJ-45 port on the 6820E/6821E .
- Connect the power adapter to the 6820E/6821E and check that the Power LED lights up. The TP Link and FX Link LED will light when all the cable connections are satisfactory.



**Figure 2-1**  
**6820E/6821E Basic Network Connection**

### 3.0 LED DESCRIPTION

LED	Color	Function
PWR	Green	Lit when power is available
FX100	Green	Lit when FX port speed is 100M
FX Link/ACT	Green Blink	Lit when fiber link is up Blink when traffic is present
FDX	Green	Lit when TP port Full Duplex Mode is enabled
TP100	Green	Lit when TP port speed is 100M
TP Link/ACT	Green Blink	Lit when TP link is up Blink when traffic is present

## 4.0 SPECIFICATIONS

<b>Standards</b>	IEEE 802.3 & IEEE 802.3u
<b>Switching Mechanism</b>	Store & Forward
<b>MAC table</b>	1K Entries
<b>Forward &amp; Filter Rate (64 Bytes)</b>	10Base-T 14,800 pps 100Base-TX 148,800 pps
<b>LED</b>	Power, FDX, TP 100, TP Link/Act, Fiber 100, Fiber Link/Act
<b>Power</b>	DC 5V, 1.6A
<b>Power Consumption</b>	5W
<b>Weight</b>	0.6 Kg
<b>Dimensions</b>	71mm x 97mm x 26mm(W x D x H)
<b>Temperature</b>	Operating: 0 ~ 50 °C Storage: -20 ~ 60 °C
<b>Humidity</b>	5% ~ 90% RH
<b>Safety</b>	UL, CSA
<b>Emission</b>	FCC/CE Class A For further reports, please contact us for update
<b>UTP</b>	Cat. 5 UTP cable
<b>Fiber</b>	Multimode 50/125, 62.5/125 Singlemode 9/125

## 5.0 REAR PANEL DIP SWITCH

Pin 1	Off/On	TP Auto-negotiation	Enable/Disable
Pin 2	Off/On	TP Speed	100M/10M
Pin 3	Off/On	TP Duplex	Full / Half
Pin 4	Off/On	Link Alarm	Disable/Enable

Default set OFF from PIN 1 to PIN 4

**Please perform Power On reset after modifying the Dip Switch setting.**

## 6.0 FIBER LINK ALARM

Link Alarm allow user easily to identify and diagnose the linking status. If set Link Alarm switch to Enable, UTP and Fiber port can link up only when both linking conditions are good. In addition, if any of the fiber or UTP port link down during operation, the other port will also turn down link to alert the user. Turn Link Alarm switch to Enable provide user transparent link indication between two network devices interconnected by 6820E/6821E.

If disable the Link Alarm. The UTP and fiber port will link up base on their individual linking condition. Further, if fiber port link down during operation, it will not turn down the UTP port link and vice versa.

### **Notice**

The Link Alarm will be effective only when the TP Auto-negotiation is enabled.

## 7.0 SERVICE PROCEDURE

### 7.1 Replacement Policy

Standard products found defective on arrival (DOA) will be replaced, based on availability, within 24 to 48 hours anywhere in the U.S. Please call Customer Service at **800-214-0222** for information.



## 7.2 Return/Repair Service

The BCI 6820E/6821E System contains no user serviceable components. If you have a problem with your unit, please contact the Customer Service Department. To facilitate our return/repair processing please contact Broadata Communications, Inc. to obtain a Return Material Authorization (RMA). Please include the following information:

- Product model number
- Serial Number
- Complete description of problem
- Hardware installation description

Broadata Communications, Inc.  
2545 West 237th Street, Suite K  
Torrance, CA 90505  
**1-800-214-0222**  
(310) 530-1416  
(310) 530-5958 (Facsimile)  
e-mail: [CustomerService@Broadatacom.com](mailto:CustomerService@Broadatacom.com)  
Website: [www.broadatacom.com](http://www.broadatacom.com)

## 8.0 LIMITED WARRANTY

Broadata Communications, Inc. (BCI) warrants, for a period of one year from date of shipment, each product sold shall be free from defects in material and workmanship. BCI will correct, either by repair, or at BCI's election, by replacement, any said products that in our sole discretion prove to be defective and are returned to the manufacturing location within 30 days after such defect is ascertained. All warranties are limited to defects arising under normal use and do not include malfunctions or failure resulting from misuse, abuse, neglect, alterations, electrical power

problems, usage not in accordance with product instructions, improper installation, or damage determined by BCI to have been caused by the Buyer or repair made by a third party. Limited warranties granted on products are to the initial customer end-user and are not transferable. OUR LIABILITY UNDER THIS WARRANTY SHALL IN ANY CASE BE LIMITED TO THE INVOICE VALUE OF THE PRODUCT SOLD AND BCI SHALL NOT BE LIABLE TO ANYONE FOR CONSEQUENTIAL OR INCIDENTAL DAMAGES ARISING FROM THE USE OF ITS PRODUCTS OR THE SALE THEREOF. We make NO WARRANTY AS TO THE MERCHANTABILITY OF ANY GOODS, OR THAT THEY ARE FIT FOR ANY PARTICULAR PURPOSE OR END APPLICATION NOR DO WE MAKE ANY WARRANTY, EXPRESSED OR IMPLIED OTHER THAN AS STATED ABOVE.







Broadata Communications, Inc.  
2545 West 237th Street, Suite K  
Torrance, CA 90505  
**1-800-214-0222**  
(310) 530-1416  
(310) 530-5958 (Facsimile)  
e-mail: [CustomerService@Broadatacom.com](mailto:CustomerService@Broadatacom.com)  
Website: [www.broadatacom.com](http://www.broadatacom.com)



6000E-6820-B<sub>1</sub>