

Auto-Cutter CL-S6621

PPN00007S-00

User's Manual

Contents

Notice.....	3
SAFETY SIGNS that must be strictly observed!.....	4
1. Function	6
2. Main specifications of auto-cutter	6
3. Checking items inside the accessory box	7
4. Auto-cutter settings.....	8
5. Cut position	10
6. Cut settings.....	11
7. Auto cut-length detection	12
8. User maintenance	13
9. Troubleshooting	14

CITIZEN is a registered trademark of CITIZEN HOLDINGS CO., Japan.

CITIZEN es una marca registrada de CITIZEN HOLDINGS CO., Japón.

Company names and product names in this manual are trademarks or registered trademarks of relevant companies.

Copyright ©2013 by CITIZEN SYSTEMS JAPAN CO., LTD.

Notice



1. **Before use, be sure to read this manual and understand. And keep it handy for reference when needed.**
2. **Do not handle, disassemble or repair any parts other than those specified in this manual.**
3. **The contents of this manual may be changed without prior notice.**
4. **Reproduction, transfer or transmission of the contents of this manual without prior consent is strictly prohibited.**
5. **We are not liable for any damage resulting from the use of this manual, regardless of omissions, errors or misprints.**
6. **We are not liable for any problems resulting from the use of optional products or consumable supplies other than those specified in this manual.**
7. **Please contact us if there are any mistakes or ambiguities within this manual.**
8. **If there are missing or incorrectly collated pages in this manual, contact us to obtain a new manual.**

SAFETY SIGNS

that must be strictly observed!

To prevent personal injury or property damage, the following must be strictly observed.

- The degree of possible injury and damage due to incorrect use or improperly following instructions specified is described below.

 WARNING	Indicates a situation which, if not observed and handled properly, could result in death or serious injury.
 CAUTION	Indicates a situation which, if not observed and handled properly, could result in personal injury or property damage.



This is a mark to call attention to the reader.

WARNING

Do not perform the following. If ignored, these may cause damage to the auto-cutter, breakdown, overheating, smoke, fire or electric shock. If the auto-cutter is damaged or breaks down, turn off the power to the printer and remove the power cord from the outlet and then consult your supplier.

- **Do not open the auto-cutter during operation.**
The cutting blade can be very dangerous. Also, this can cause damage.
- **Prevent foreign matter from entering small openings of the auto-cutter**
Inserting your finger or other foreign matter in the small openings of the auto-cutter can be extremely dangerous and can damage the cutter.
- **The user should never install or remove the auto cutter.**



CAUTION

- **Avoid the following conditions to ensure proper operation of the auto-cutter.**
 - The cutting blade can be very dangerous. Also, this can cause damage.
 - Room temperature is less than 5°C or more than 40°C.
 - Humidity is less than 30% or more than 80%.
 - Dusty
 - Direct sunlight
 - Chemicals
 - Vibrations or impacts
- **When cutting media (paper)**
 - Do not operate auto-cutter without loading paper. This can cause damage to the cutter.
 - Use the standard media (paper). Otherwise, problems such as paper jams may occur.
 - Remove any dust or particles from the paper guide and path periodically.
 - When auto-cutter is cleaned, turn off the power to the printer and remove the power cord from the outlet beforehand.
 - Clean the main body of the auto-cutter with a soft cloth that is soaked in a thinned neutral detergent. Do not use volatile solvent such as benzene and thinner, which can cause discoloration.
 - When the cutter blade becomes dirty, contact your supplier or a service representative.

1. Function

The auto-cutter units are designed to cut various media such as labels, tickets and tags precisely and accurately as the setting cut length.

2. Main specifications of auto-cutter

- Cutting method: Guillotine cutter
- Maximum cut paper thickness: 0.25 mm (0.01")
- Minimum cut paper length: 25.4 mm (1")
- Cut paper width: Maximum: 177.8 mm (7")
Minimum: 50 mm (1.97")
- Durability:
 - Number of cuts: Minimum 500,000 times
(for a paper thickness of 60 to 150 µm)
Minimum 200,000 times
(for a paper thickness of 150 to 250 µm)

Note

- Media with adhesive substance may be excluded from the number of cuts.
- The number of cuts can vary according to the quality of the paper.

- Media and paper types:
 - Roll or label (continuous, die-cut, fanfold, tag and ticket).
 - However, the following paper cannot be used:
 - Paper with thickness of 0.06 mm (0.0024") or less
 - Roll paper with paper core diameter of 50 mm (2") or less

Note Using paper other than the specified types may cause problems such as paper jams, so the paper specification must be checked before use.

- Cut accuracy:
 - Cut length tolerance: ± 1.5 mm or less
 - Left and right cut tolerance: ± 1.5 mm

Note Cutting position can be adjusted using printer commands (see page 11).



- When using adhesive media, do not cut the liner itself. Adjust the printer to cut the liner only. If label glue sticks to the cutter blades, irregular cutting will occur.

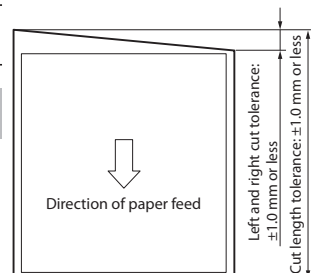

3. Checking items inside the accessory box

Note Auto-cutter is not available for the printer with the peeler.

You should check that all of the following items are inside the accessory box. If any are missing, please contact your supplier.

Cutter Stand Unit	1 piece
Cutter Unit	1 piece
Screws (E00130-06W)	2 pieces
User's Manual (PXZ80075)	1 piece
Manual for service personnel (PXZ80076)	1 piece

Cutter Unit

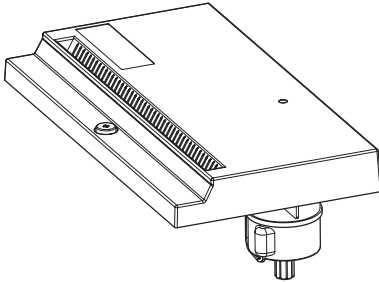

Cutter Stand Unit

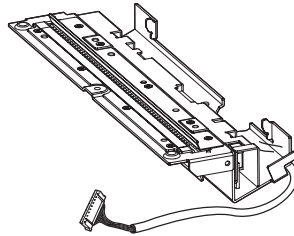

Screws (2)

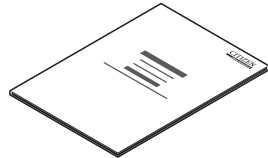

User's Manual

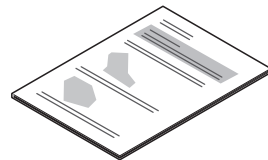

Manual for service personnel

4. Auto-cutter settings

"Cut On" menu will be selected automatically when the auto-cutter is installed; thus, the printer can be used without adjustment. However, some printers may not have the "AutoConfigure" function. In this case, select the "After Print" menu of the menu setup mode, and the "Cut On" menu on the "Function Select" menu. If the printer has the "AutoConfigure" function, the "AutoConfigure" menu will be printed out in front of "Function Select" menu when you print the "Current Setup".

Note See the printer's User's Manual (CD-ROM) for details on "Print Menu Settings".

Loading Media

- (1) Press the printhead lever, and then open the head unit and sensor arm.

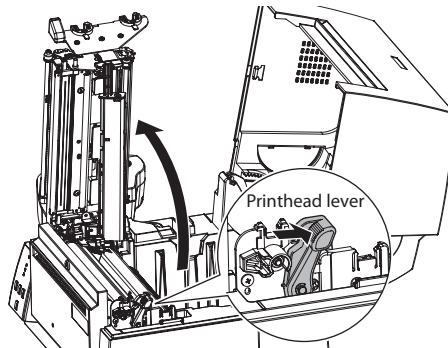

- (2) With scissors, cut the end of the media loaded in the media holder.
- (3) Feed the end of the media through the cutter assembly until the end extends 10 mm past the cutter cover.
- (4) Close the head unit and sensor arm.

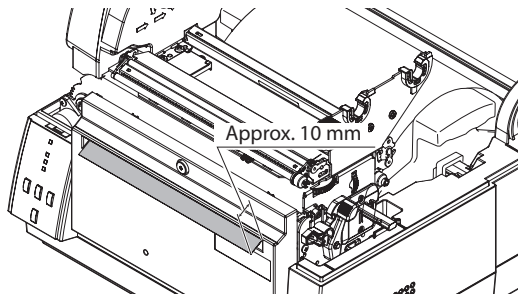

- (5) The cutter will operate one time when the FEED key is pressed.

 **CAUTION**

- When a paper jam has occurred, or when the auto cutter has malfunctioned, your supplier or your service representative. Never attempt to repair the auto cutter yourself, it could result in a risk of injury.

5. Cut position

The following diagram gives the distance from the media sensor and the thermal printhead to the cutter blade.

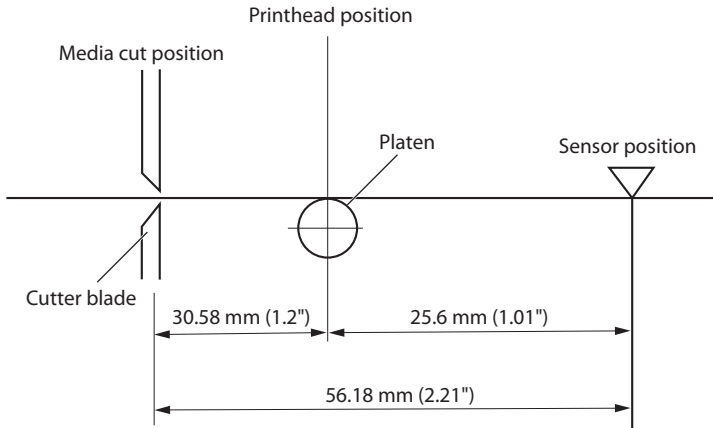

Note

The measurements shown here are approximate.

7. Auto cut-length detection

If media with a cut length shorter than the minimum cut length of 25.4 mm (1.0 in) is used, the cut media may remain in the cutter unit and cause paper jams. To prevent this, when the printer detects a cut length shorter than the minimum, it feeds the media without operating the cutter. Therefore, use a cut length of 25.4 mm (1.0 in) or longer when setting the media cut length.

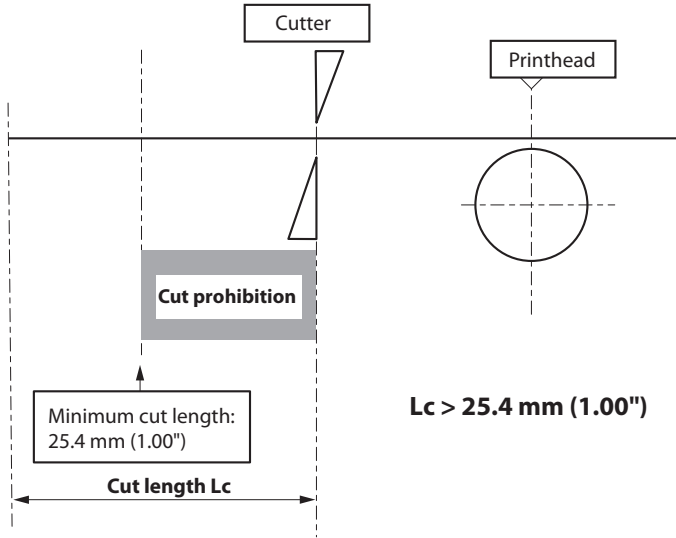

Note Media is fed and not cut when its media cut length is 12.7 mm (0.5 in) or less. However, if the total length of several labels (for example, two or more) on one label sheet is more than 12.7 mm (0.5 in), the media can be cut in intervals of multiple labels (for example, every two or more labels).

Example:

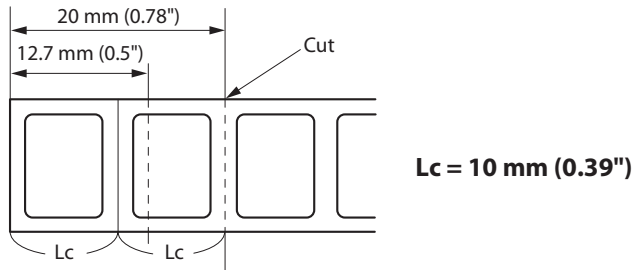

8. User maintenance

If the platen of the printer becomes dirty, the cutter may perform defective cutting even if the auto cutter does not malfunction. Therefore, clean the platen regularly. (See the printer user's manual)

Remove the platen

- (1) Push the head open lever downwards to open the head unit and sensor arm.
- (2) Grasp the mounting device of the platen and lift it up as shown in the figure.

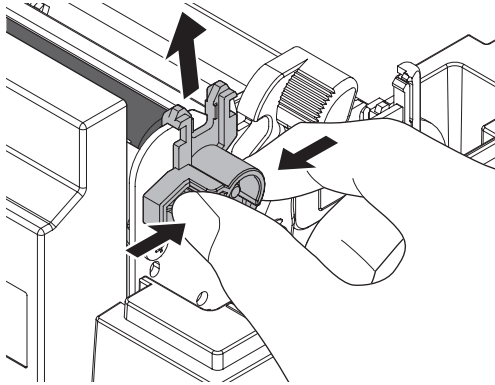

- (3) Remove the gear side of the platen, and remove the platen while pulling the mounting device of the platen toward you.

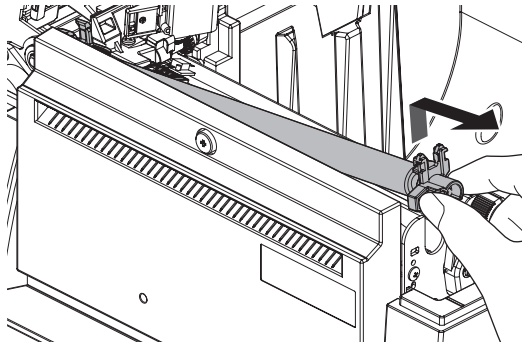

- (4) Remove dirt from the platen with a soft cloth or cotton swab containing a small quantity of ethyl alcohol. (See the printer user's manual)

9. Troubleshooting

If an error is detected, an alarm will sound and an LED on the control panel will display the nature of the error.

List of error displays

Error	Print LED	Condition LED	Error LED
Media Out (media location cannot be detected)	OFF	ON OFF	ON OFF
Auto Cutter Abnormality (such as blade jamming)	OFF	OFF	ON
Abnormal auto-cutter temperature	ON OFF	OFF ON	OFF



Contact your supplier or service representative, if the following conditions are observed.

- The cutter does not cut the media well.
The blade of the cutter may be worn out or covered by a label glue.
- Above error condition is occurred.

CITIZEN SYSTEMS AMERICA CORPORATION

363 Van Ness Way, Suite 404
Torrance, CA 90501. USA
Tel: (310) 781-1460
Fax:(310) 781-9152
<http://www.citizen-systems.com>

CITIZEN SYSTEMS EUROPE GmbH

Mettinger Strasse 11	Park House, 643-651 Staines Road
D-73728, Esslingen	Feltham, Middlesex, TW14 8PA
Germany	United Kingdom
Tel: +49 (0) 711 3906 400	Tel: +44 (0) 20 8893 1900
Fax:+49 (0) 711 3906 405	Fax: +44 (0) 20 8893 0080
http://www.citizen-europe.com	

CITIZEN SYSTEMS JAPAN CO., LTD.

6-1-12, Tanashi-cho, Nishi-Tokyo-shi
Tokyo, 188-8511. Japan
Tel: +81 (0) 42 468 4608
Fax:+81 (0) 42 468 4687
<http://www.citizen-systems.co.jp>