

# Device/PLC Connection Manuals

---





## About the Device/PLC Connection Manuals

Prior to reading these manuals and setting up your device, be sure to read the "Important: Prior to reading the Device/PLC Connection manual" information. Also, be sure to download the "Preface for Trademark Rights, List of Units Supported, How to Read Manuals and Documentation Conventions" PDF file. Furthermore, be sure to keep all manual-related data in a safe, easy-to-find location.

## 9.2 Remote Device Station

### 9.2.1 System Structure

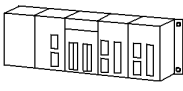
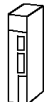
#### ■ A series/QnA series (Link I/F)

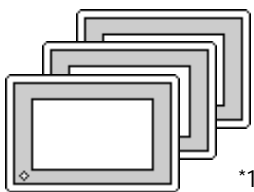
CPU	Link	Wiring Drawing	Cable(s)	Unit	GP
					 *1
A2A A3A A3N A2U-S1	AJ61BT11	RS485 (refer to next page)	Kuramo Electronics' FANC-SB0.5mm <sup>2</sup> x3	CC-Link Unit GP070-CL11	GP Series *2
A2US A2USH-S1	A1SJ61BT11		Twisted Pair Shielded Cable		
Q3A Q4A	AJ61QBT11				

\*1 All GP Units connected to the Master station have the following conditions:

- (1)  $\{(1 \times a) + (2 \times b) + (3 \times c) + (4 \times d)\} \leq 64$   
a: No. of units occupying 1 node  
b: No. of units occupying 2 nodes  
c: No. of units occupying 3 nodes  
d: No. of units occupying 4 nodes
- (2)  $\{(16 \times A) + (54 \times B) + (88 \times C)\} \leq 2304$   
A: No. of Remote I/O nodes used  $\leq 64$   
B: No. of Remote Device nodes  $\leq 42$   
C: No. of Local nodes  $\leq 26$

#### Maximum No. of Connectable GPs

The GP will become a Remote Device node and the minimum number of occupiable nodes becomes two (2). As a result, the number of GPs that can be connected to a single Master node is 32.

**Reference** For detailed information about the Master node's system design, please refer to *Mitsubishi Electric [AJ61BT11/A1SJ61BT11] Unit CC-Link System Master and Local Unit User's Manual*, or the *[AJ61QBT11/A1SJ61QBT11] Unit CC-Link System Master and Local Unit User's Manual's [System Design] section*.

\*2 The GP/GLC series applicable for CC-Link Remote Device Station listed below:

Series Name		Product Name	Unit
GP70 Series	GP-470 Series	GP-470E	Units Applicable to CC-Link <sup>*1</sup>
	GP-570 Series	GP-570S	
		GP-570T	
		GP-57JS	
		GP-570VM	
	GP-571 Series	GP-571T	
	GP-675 Series	GP-675S	
		GP-675T	
GP-870 Series	GP-870VM		
GP77R Series	GP-477R Series	GP-477RE	
	GP-577R Series	GP-577RS	
		GP-577RT	
GP2000 Series	GP-2500 Series	GP-2500L	
		GP-2500S	
		GP-2500T	
	GP-2501 Series	GP-2501S	
		GP-2501T	
	GP-2600 Series	GP-2600T	
GP-2601 Series	GP-2601T		
GLC2000 Series	GLC2500 Series	GLC2500T	
	GLC2600 Series	GLC2600T	

\*1 When using GP2000/GLC2000 series units, a bus conversion unit (PSL-CONV00) is required.

### 9.2.2 Cable Diagram

When connecting the GP (Remote Unit) to the PLC (Master Unit), use twisted pair cable and wire the connectors as follows:

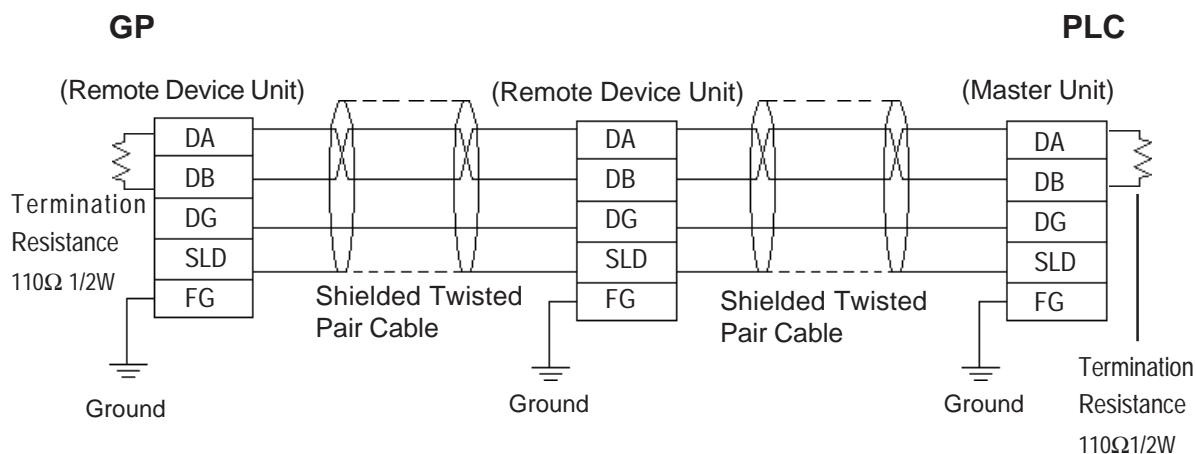

- **Be sure to attach termination resistors to each end of a linked system, between DA-DB. A Terminating Resistor is already attached to the PLC's CC-Link unit.**
- **The GP becomes the remote device node.**
- **The node order and the actual unit connection order are not related.**
- **T-type and Star-type connections are not possible.**

**9.2.3 Environment Settings**

The following are Digital’s recommended data transmission settings for the PLC and GP.

**■ Mitsubishi Electric A and Q Series Units**

GP Settings		PLC CC-Link Unit Settings	
Transfer Speed	10M, 5M, 2.5M, 625K, 156K	Transfer Speed	Set via Rotary Switch
Occupied Nodes	2 to 4	Occupied Nodes	Ladder program is used to set no. of occupied nodes in the Node Information area. *1
No. of Nodes	1 to 63	No. of Nodes	Ladder program is used to set Node No. in the Node Information area. *1 *2
Node Type	Remote Device Station (fixed)	Node Type	Ladder program is used to set the Node Type in the Node Information area. *1
Monitoring Method	Ordinary Monitor, Command Monitor	Monitoring Method	Can be entered via Ladder program *3
Environment Settings	Use GP screen to enter settings (See Foot Note *4)		

\*1 For detailed information about the Master station’s system design, please refer to *Mitsubishi Electric [AJ61BT11/A1SJ61BT11] Unit CC-Link System Master and Local Unit User’s Manual*, or the *[AJ61QBT11/A1SJ61QBT11 Unit CC-Link System Master and Local Unit User] Manual’s [System Design] section*.

\*2 The Master Node’s node number must always be set to “0”. (Use the Master Unit’s rotary switch)

\*3 Only the settings on the GP can be changed. If, however, a ladder program has been used to enter settings (using Initial Setting commands), those settings are the highest priority.

\*4 (HOW TO SET UP THE GP SCREEN)

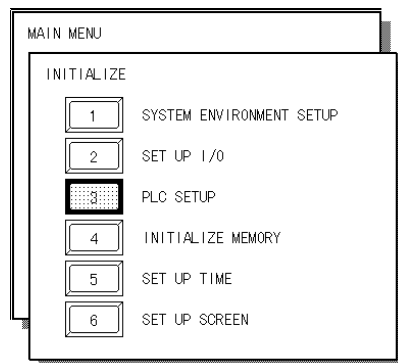

1. Touch the [PLC SETUP] selection.

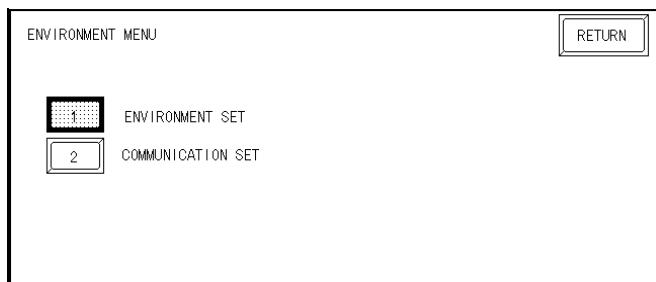

2. Touch the [ENVIRONMENT SET] selection.

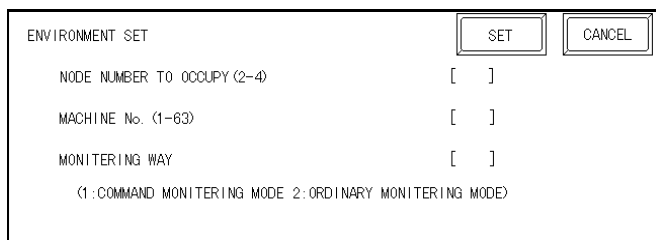

In the [ENVIRONMENT SET] menu:

Enter the desired settings for Node Number to Occupy, Machine No. and Monitoring Way.

**NODE NUMBER TO OCCUPY** enter 2, 3 or 4.

**MACHINE NO.** enter from 1 to 63 for the machine number. If “3” occupied nodes are used, the limit is 62; if “4” occupied nodes are used, the limit is 61.

**MONITORING METHOD** either Command or Ordinary Monitoring can be used.

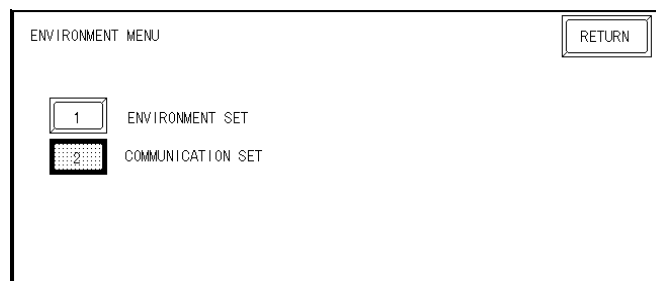

3. Touch the [COMMUNICATION SET] selection.

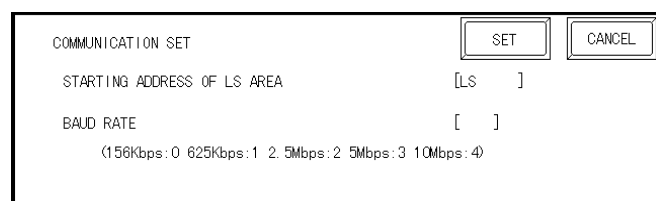

In the [COMMUNICATION SET] menu:

Enter the [STARTING ADDRESS OF LS AREA] and [BAUD RATE] settings.

**STARTING ADDRESS OF LS AREA** This start address is used for the allocation of the Remote Input/Output and Remote Device Areas in the GP’s System Area (20 to 1980).

**9.2.4 Monitoring Specifications**

**9.2.4.1 Overview**

When using the CC-Link, the GP must be registered as a Remote Device node and use a direct connection with a CC-Link compatible PLC. Here, either the Ordinary or Command Monitoring method can be used.

**◆ Ordinary Monitoring**

The Master Node's devices are occupied (via Link Areas) in the GP's System Area, as shown below.

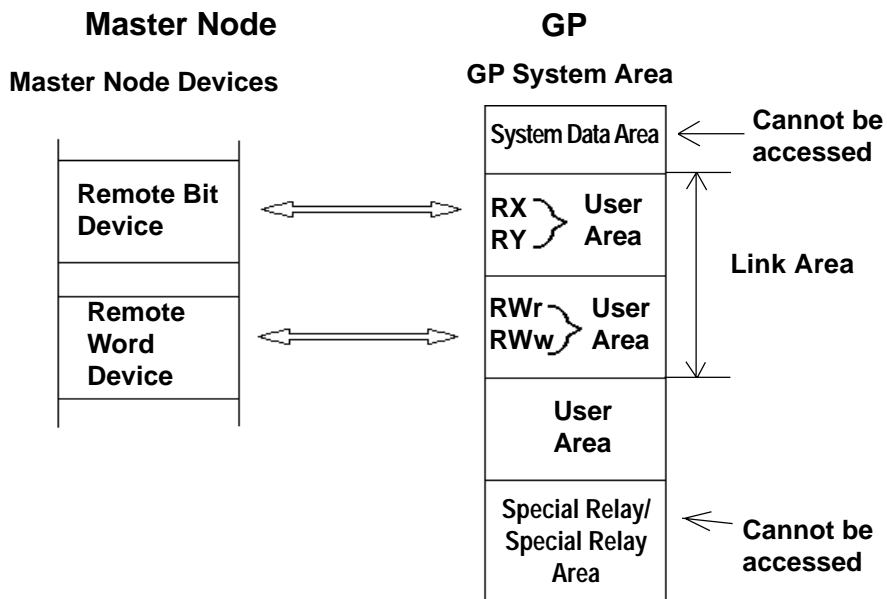

**When using the Ordinary Monitoring method, the System Device Area and the Special Relay Area cannot be accessed.**

- **Command Monitoring**

The Remote Bit Device, like the Ordinary Monitor, can directly access the User Area's Bit Device.

The Remote Word Device, depending on the commands entered to the device, can directly access the GP's User and System areas.

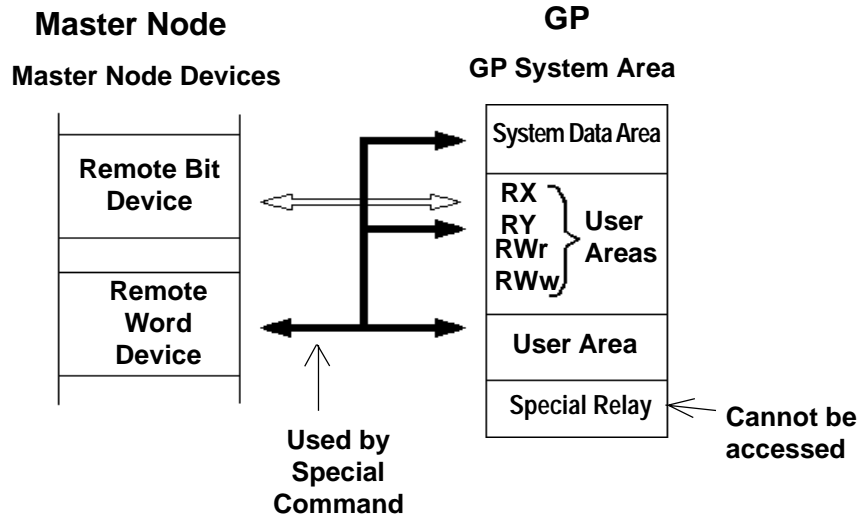

- **Using Indirect Access**

The CC-Link Special Command (write/read commands) can be used to store/access data in the GP System Area's Remote Word Device.

**Reference** 9.2.3 ■ *Command Monitoring*



- **The contents of the System Data Area will convert to Memory Link type.**
- **When using Command Monitoring, data cannot be written to the RX, RY, RWw, or RWr user areas.**
- **The GP's Special Relay area cannot be accessed.**



**■ GP I/O Designations**

**From GP to Master Station**

Link Output	Signal Name
RX m0	<u>User Area</u>  The following number of nodes can be occupied:  2 nodes: 48 points 3 nodes: 80 points 4 nodes: 112 points
RX m1	
RX m2	
RX m3	
RX m4	
RX m5	
RX m6	
RX m7	
RX m8	
RX m9	
RX mA	
RX mB	
RX mC	
RX mD	
RX mE	
RX mF	
::	
RX (m+n) 0	Display Completed Flag
RX (m+n) 1	Reserved for System Area
RX (m+n) 2	
RX (m+n) 3	
RX (m+n) 4	
RX (m+n) 5	Reserved
RX (m+n) 6	Touch ON Completed Flag
RX (m+n) 7	Reserved
RX (m+n) 8	Tag Code Output Request Flag
RX (m+n) 9	Reserved
RX (m+n) A	Initial Data Setting Completed Flag
RX (m+n) B	Error Condition Flag
RX (m+n) C	Remote Ready
RX (m+n) D	Reserved
RX (m+n) E	Reserved
RX (m+n) F	Reserved

**From Master Station to GP**

Link Output	Signal Name
RY m0	<u>User Area</u>  The following number of nodes can be occupied:  2 nodes: 48 points 3 nodes: 80 points 4 nodes: 112 points
RY m1	
RY m2	
RY m3	
RY m4	
RY m5	
RY m6	
RY m7	
RY m8	
RY m9	
RY mA	
RY mB	
RY mC	
RY mD	
RY mE	
RY mF	
::	
RY (m+n) 0	Display Request Flag
RY (m+n) 1	Display Monitor Request Flag
RY (m+n) 2	Display Periodic Write Request Flag
RY (m+n) 3	Reserved for System Area
RY (m+n) 4	
RY (m+n) 5	
RY (m+n) 6	
RY (m+n) 7	Reserved
RY (m+n) 8	Initial Data Setting Request Flag
RY (m+n) 9	Reserved
RY (m+n) A	Error Reset Request Flag
RY (m+n) B	Reserved
RY (m+n) C	Reserved
RY (m+n) D	Reserved
RY (m+n) E	Reserved
RY (m+n) F	Reserved



**m:** (Node No. - 1) x 2H

**n:** As stated below

No. of Occupied Nodes	2 Nodes	3 Nodes	4 Nodes
n	3	5	7

- GP I/O Definition Details

### From GP to Master Station

Link Input	Signal Name	Explanation
RX (m+n) 0	Display Completed Flag *1	When the Display Completed Flag (RY (m+n)0) turns ON, the GP's Processing Completed will turn ON. Also, when the GP turns the Display Request Flag OFF, the Display Completed Flag also turns OFF.
RX (m+n) 5	Touch ON Completed Flag	When data is written to the GP's System Data Area 13, Rx(m+n)5 will turn ON. The PLC then uses the Continuous Read Command, and, after reading the contents of the GP's System Data Area 13, it turns OFF.
RX (m+n) 7	Tag Code Output Request Flag	Same as RX(m+n)5.
RX (m+n) 9	Initial Data Setting Completed Flag *1	When the Initial Data Setting Request (RY(m+n)9) turns ON, the Initial Data Setting Completed will also turn ON. Also, when the Initial Data Setting is completed, the Initial Data Setting Request Flag and the Initial Data Setting Completed Flag will both turn OFF.
RX (m+n) A	Error Condition Flag	When a command error occurs while the GP's System Area is being used, this flag turns ON.
RX (m+n) B	Remote Ready	When the GP has been changed to ONLINE mode and data linking has been completed successfully, this turns ON. Also, when the GP is in either OFFLINE mode or having its Initial Data entered, this turns OFF.

### From Master Station to GP

Link Input	Signal Name	Explanation
RY (m+n) 0	Display Request Flag *1	When a read or write are being performed to the GP's System Area, this flag turns ON.
RY (m+n) 1	Display Monitor Request Flag *1	When the System Area is being read of a GP that has had Monitor Registration performed for its RWm area, this flag turns ON.
RY (m+n) 2	Display Periodic Write Request Flag *1	When the System Area is being written to on a GP that has been registered for the periodic writing of data previously written to the RWwm area, this flag turns ON.
RY (m+n) 9	Initial Data Setting Request Flag *1	Initial processing is performed when this flag is ON.
RY (m+n) A	Error Reset Request Flag	When the Error Reset Request Flag turns ON, the Error Condition Flag RX(m+n)A turns OFF.

\*1 Only needed during Special Command Monitor. Normally not used.

- **Display Completed Flag, Display Request Flag**

When the Display Request Flag turns ON, the completion of command processing causes the Display Completed Flag to turn ON. When the Display Request Flag turns OFF, the Display Completed Flag will also turn OFF. Be sure to use the ladder program to turn OFF the Display Request Flag after checking the Display Completed Flag has been turned ON.

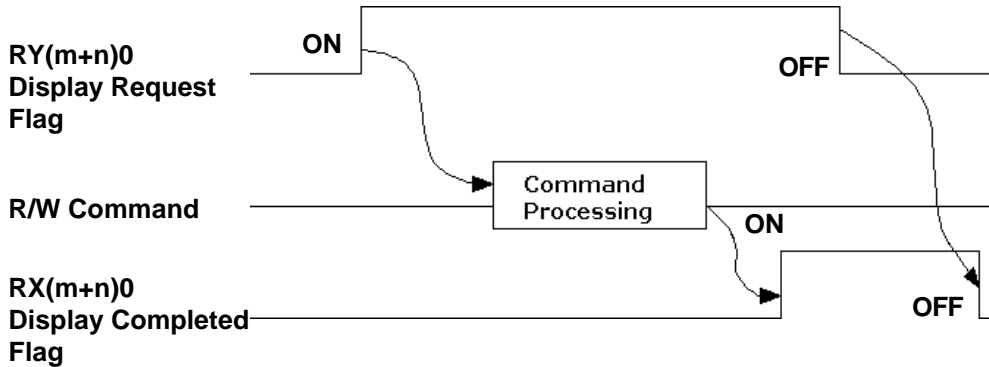

- **Initial Data Setting Completed Flag, Initial Data Setting Request Flag**

When the Initial Data Setting Completed Flag turns ON, the completion of the initial processing causes the Initial Data Setting Completed Flag to turn ON. When the Initial Data Setting Request Flag turns OFF, the Initial Data Setting Completed Flag turns OFF.

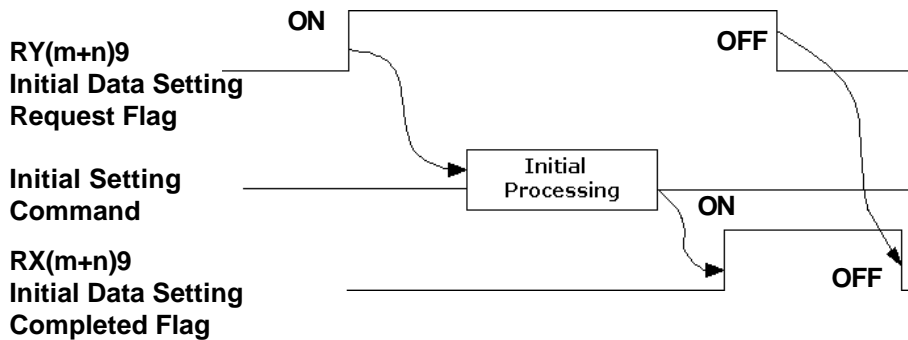

- **Error Condition Flag, Error Reset Request Flag**

When the Command Monitor feature is being used and an error occurs, the Error Condition Flag and the Error Reset Request Flags both turn ON, causing the Error Condition Flag to turn OFF.

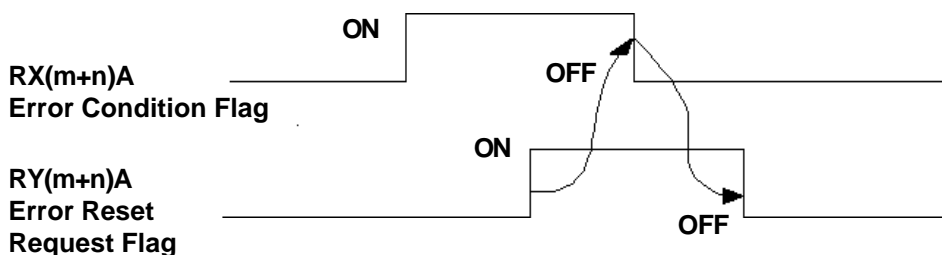

- **Display Monitor Request Flag**

When the Display Monitor Request Flag turns ON, data from the system area of the GP registered for monitoring will be read out.

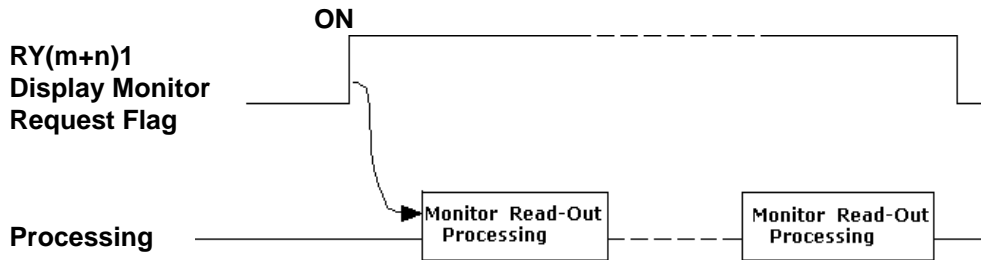

- **Periodic Display Write Request Flag**

While the Periodic Display Write Request is ON, data is periodically written to a registered GP's system area.

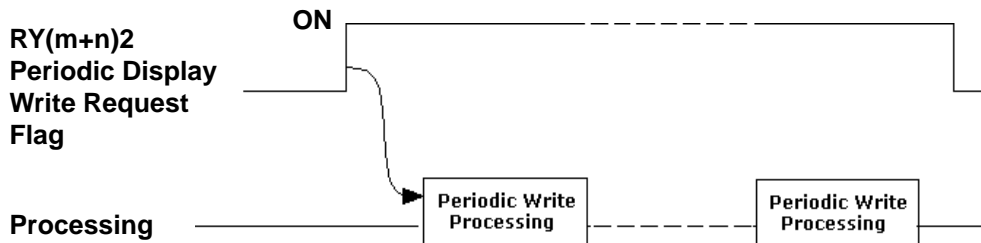

- **Remote Ready**

When the GP's OS is started and online, the Remote Ready:RX(m+n)B bit is ON.

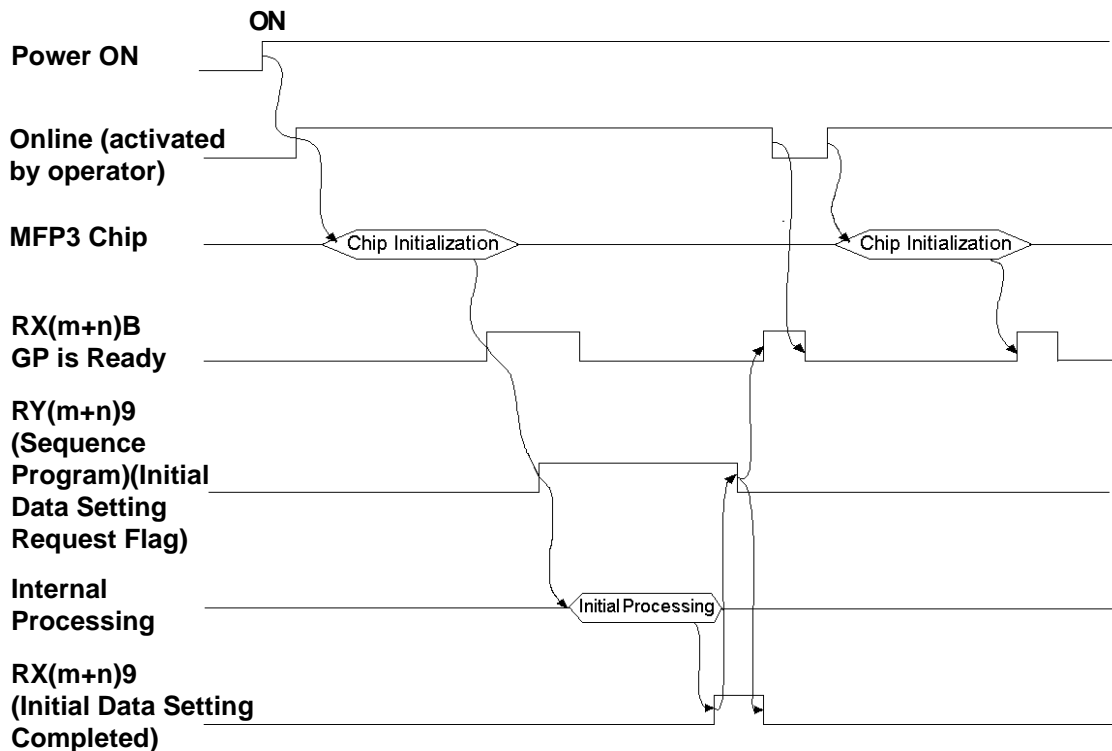

### ■ Sending Tag Codes to the Master Node

This feature is for sending Tag Code data from the GP's System Area to the Master Node, via the GP's touch panel. When a GP touch or other type of tag is used to perform an absolute write to the GP's System Data Area 13 (decimal), the RX(m+n)5 (Touch ON Complete Flag) turns ON. When this bit turns ON, the RX(m+n)7 (Tag Code Read Request Flag) also turns ON.

When the Master Node is performing continuous read requests on the GP's System Data Area 13, prior to a Read being completed, the GP will turn RX(m+n)5 OFF. This, in turn, will cause the RX(m+n)7 bit to turn OFF. This method is used to send numeric data from the GP's touch panel (using the 8 bit interrupt codes shown below) to the Master Node.

- Input/Output Signal Timing

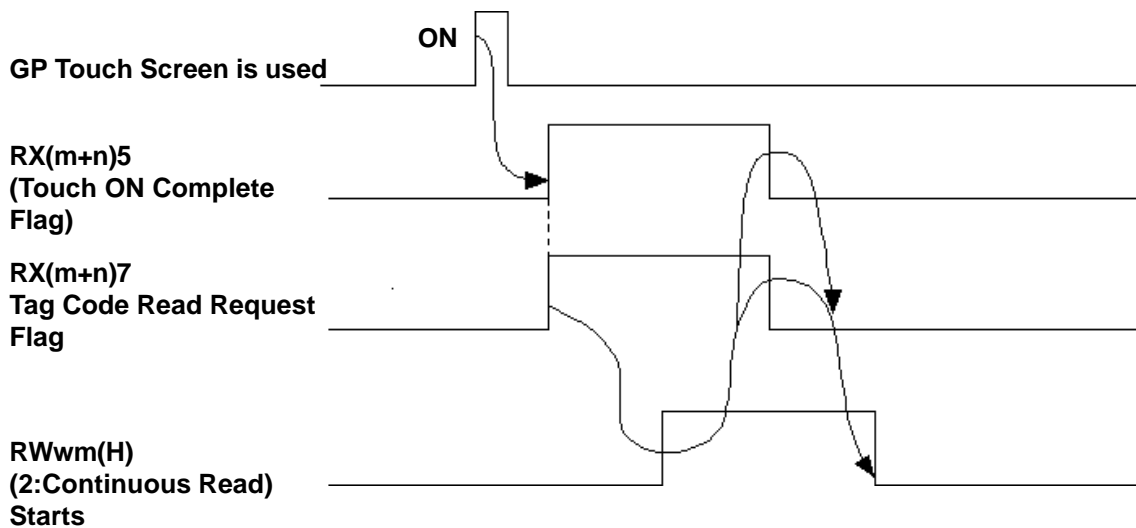

9.2.4.2 Ordinary Monitoring

• GP Register Descriptions

From Master Station to GP

Address	Contents
RW wm	When 2 Nodes are occupied: 8 points
RW wm+1	
RW wm+2	
RW wm+3	
RW wm+4	
RW wm+5	
RW wm+6	
RW wm+7	
RW wm+8	When 3 Nodes are occupied: 12 points
RW wm+9	
RW wm+A	
RW wm+B	
RW wm+C	When 4 Nodes are occupied: 16 points
RW wm+D	
RW wm+E	
RW wm+F	

From GP to Master Station

Address	Contents
RW rn	When 2 Nodes are occupied: 8 points
RW rn+1	
RW rn+2	
RW rn+3	
RW rn+4	
RW rn+5	
RW rn+6	
RW rn+7	
RW rn+8	When 3 Nodes are occupied: 12 points
RW rn+9	
RW rn+A	
RW rn+B	
RW rn+C	When 4 Nodes are occupied: 16 points
RW rn+D	
RW rn+E	
RW rn+F	



Concerning the characters m and n:

The chart here shows how the Remote Register's 4h units are calculated.

Machine No.	m	n
1	0	100
2	4	104
3	8	108
~	~	~



With Ordinary Monitoring, the value written into the Master Node's RWw area is reflected in the User Area's Link Area RWw(+36 to +51). Also, the value in the User Area's Link Area RWr(+20 to +35) is reflected in the Master Node's RWr.

**Reference** 9.2.3 ■ Occupied Nodes.

• Ordinary Monitoring Sequence Drawing

(Sequence Program)

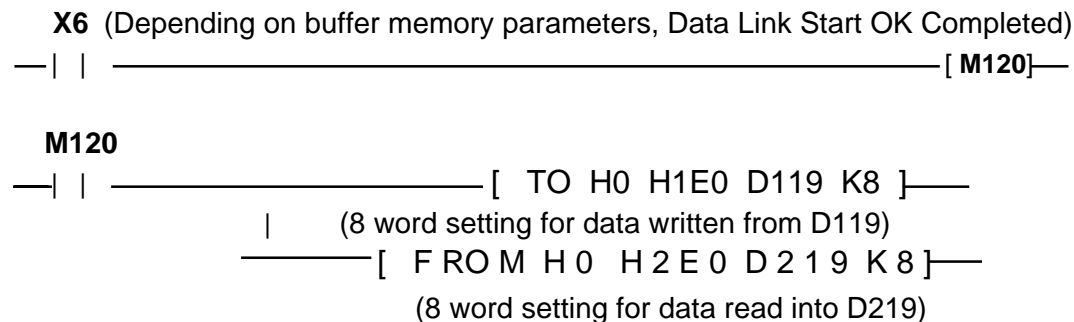

■ PLC (Sequencer) Program for Displaying Ordinary Monitor Data

The following drawing shows the PLC's CPU and Master Node Buffer Memory, in addition to the GP's System Data Area.

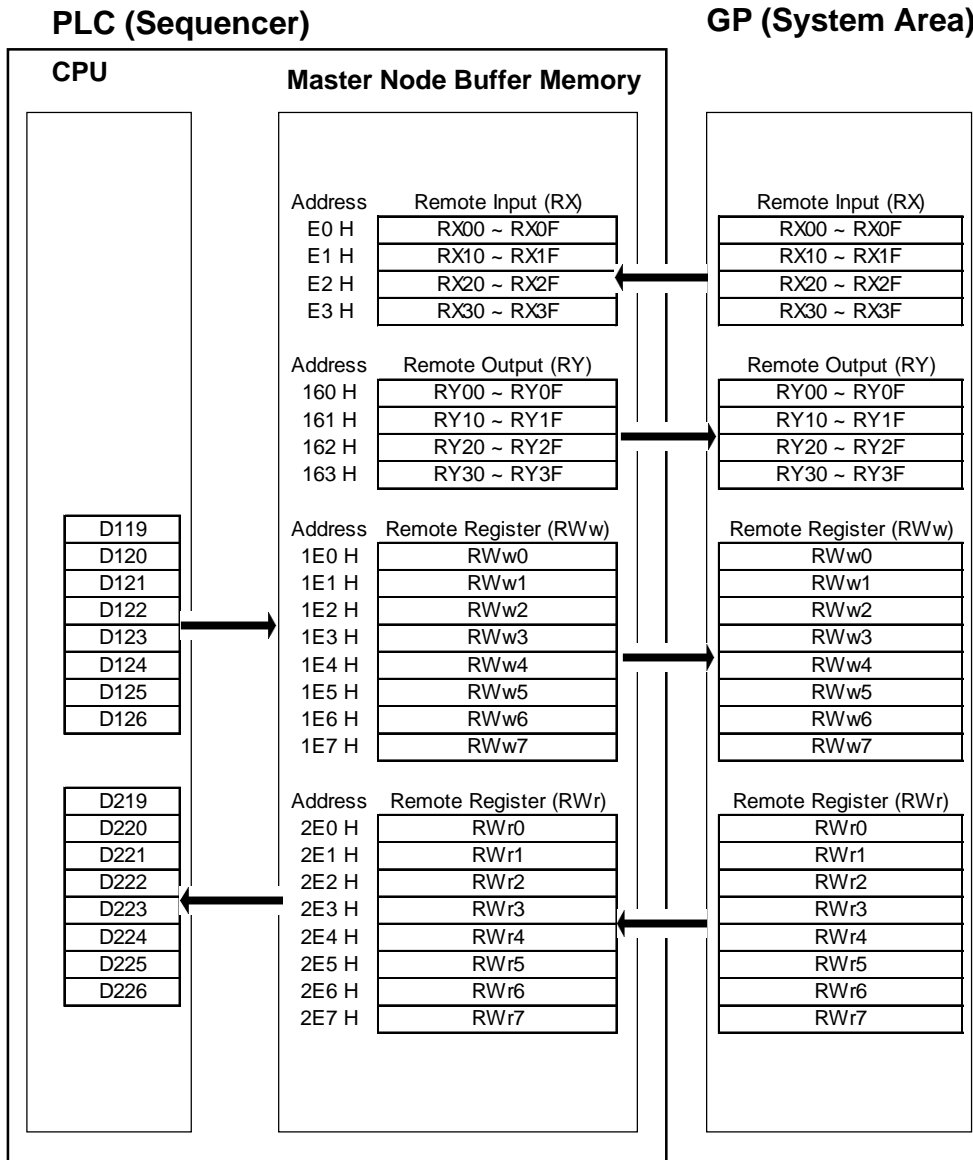

The above chart shows examples of when the CPU's D119 to D126 data is sent to RWw0 to RWw7, and when RWr0 to RWr7's data is sent to D219 to D226.

9.2.4.3 Command Monitoring

■ GP Register Descriptions

◆ Master Node to GP

Address	Contents
RW wm	<b>Command</b>
RW wm+1	When each command (refer to the each command details) occupies 2 Nodes: 8 points.
RW wm+2	
RW wm+3	
RW wm+4	
RW wm+5	
RW wm+6	
RW wm+7	
RW wm+8	When 3 Nodes are occupied: 12 points
RW wm+A	
RW wm+B	
RW wm+C	When 4 Nodes are occupied: 16 points
RW wm+D	
RW wm+E	
RW wm+F	

◆ GP to Master Node

Address	Contents
RW rn	<b>Response</b> *1
RW rn+1	When each command (refer to the each command details) occupies 2 Nodes: 8 points.
RW rn+2	
RW rn+3	
RW rn+4	
RW rn+5	
RW rn+6	
RW rn+7	
RW rn+8	When 3 Nodes are occupied: 12 points
RW rn+9	
RW rn+A	
RW rn+B	When 4 Nodes are occupied: 16 points
RW rn+C	
RW rn+D	
RW rn+E	
RW rn+F	



**Concerning the characters m and n:**

The chart here shows how the Remote Register's 4h units are calculated.

Machine No.	m	n
1	0	100
2	4	104
3	8	108
~	~	~

\*1 Error code will be set only when errors occur.

**Reference** 9.2.6 Error Codes



■ Signal Details

The following drawing shows the PLC’s CPU and Master Node Buffer Memory, in addition to the GP’s System Data Area.

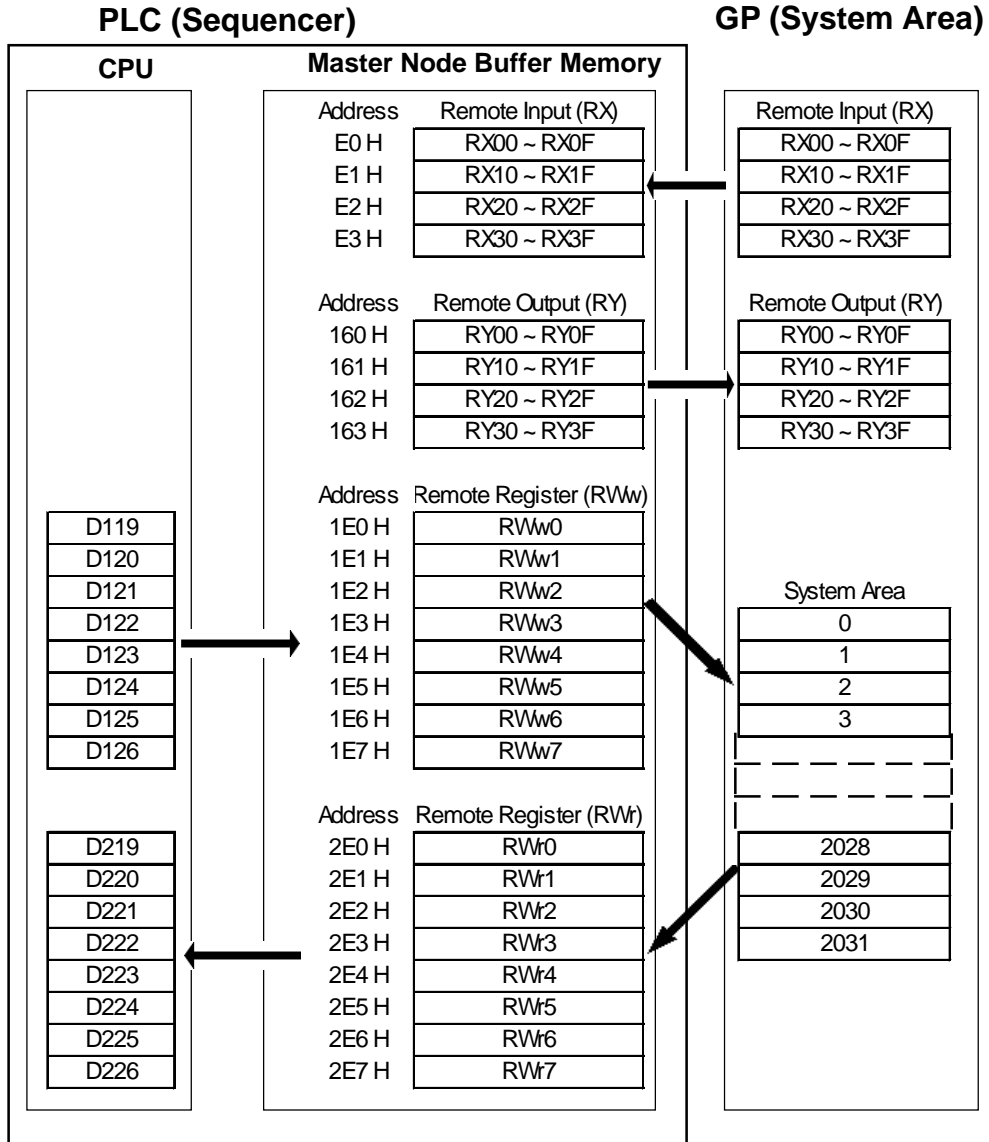

The figures show the PLC CPU’s D119 used as the start address for the storage of commands, with D129 being used as the start address for the storage of read out data.

### ■ Command List

Command No.	Name	Contents
1	Initial Setting Command	Changes the current Mode.
2	Continuous Read Command	Reads out each piece of word data from the GP System Area's designated address.
3	Random Read Command	Reads out data from multiple GP System Area addresses.
4	Continuous Write Command	Writes each piece of word data to the designated GP System Area address.
5	Random Write Command	Writes data to multiple GP System Area addresses.
6	Register Monitor Command	Registers multiple GP System Area addresses for monitoring.
8	Register Periodic Write Command	Registers multiple GP System Area addresses for writing.

### ◆ Initial Setting Command

Command details and sequence program examples are given below.

In each of the example sequence programs, the GP unit node number is 1, and the occupied node is 2.

Address	Contents
RWwm (H)	1: Initial Settings
RWwm (L)	1: Use Command Monitor Mode 2: Use Ordinary Monitor Mode
RWwm +1 to RWwm +F	Cannot be used
RWrn to RWrn +F	Cannot be used



**The Initial Setting command (either Ordinary or Command Monitor) can also be designated via the GP's OFFLINE mode. However, if this command is designated via a ladder program, the ladder program has priority. If no ladder program settings are present, the OFFLINE mode settings are enabled.**

< Sequence Program Example > (Uses Initial Setting command to operate the Command Monitoring Mode.)

```

—[ <> k 1 D 1 0 0 0 ]————— [ MOV H 1 0 1 D 1 1 9 ]——
      (Initial Setting Command (H) and Command Monitor Mode (L) settings)
      —————[ TO H 0 H 1 E 0 D 1 1 9 K 1 ]——
      | (Save the above settings to the designated buffer address)
      —————[ TO H 0 H 1 6 3 H 2 0 0 K 1 ]——

(Initial Data Setting Request Flag ON)
M 9036(Normally ON)
— || ————— [ FROM H 0 H E 3 D 1 0 0 0 K 1 ]——
| (Save Initial Data Setting Completed Flag to D1000)
— [ SFR D 1 0 0 0 K 9 ] —
      (Shift all data 9 bits to the right)

—[ = k 1 D 1 0 0 0 ] — Ladder program for performing another command

```

■ Continuous Read Command

Address	Contents
RWwm (H)	2: Continuous Read
RWwm (L)	1-14: No. of Words (W/4 occupied nodes: max. 14 points, w/3 occupied nodes: max. 10 points, w/2 occupied nodes: max. 6 points)
RWwm +1	0 to 2031: GP System Area's designated address
RWwm +2 to RWwm +F	Cannot be used
RWrn to RWrn +D	Reads out each piece of word data from the GP System Area's designated address.
RWrn +E to RWrn +F	Cannot be used

< Sequence Program Example > (Continuous Read of 6 words from address 0 in GP memory)

```

X6 (Data Link normal startup completed using buffer memory's parameter)
—| |-----[ SET M110 ]—
M110
—| |-----[ MOV K518 D119 ]—

| ( Sets 2 : Continuous Read(H), and 6 : no. of points(L) )
|-----[ MOV K0 D120 ]—
| ( Designates Address 0 in GP Memory )
|-----[ TO H0 H1E0 D119 K2 ]
| ( Saves above settings to the buffer memory )
|-----[ MOV K1 D149 ]—
|
|-----[ TO H0 H163 D149 K1 ]
| ( GP Request Flag ON )
|-----[ FROM H0 H2E0 D229 K6 ]—
( Saves Continuous Read values in device D229)
    
```

In order to send T-tag data to a PLC, and also enable the master station to read the touched value using the Continuous Read command.

< Sequence Program Example (Using LS13) > ( Values in brackets( ) are when LS10 is used)

```

X6 (Data Link normal startup completed using buffer memory's parameter)
—| |-----[ SET M110 ]—
M9036 (Normally ON)
—| |-----[ FROM H0 HE3 D1000 K1 ]—
| ( Saves Data stored in Buffer memory to D1000 )
|-----[ SFR D1000 K5 ]—
( Shifts all data 5 bits to the right ) ( K 6 )
— [ = H45 D1000 ]-----[ MOV K518 D119 ]—
( H 2 3 ) | ( Designates 6 words for Continuous Read )
(Touch ON Completed Flag)-----[ MOV K13 D120 ]—
| ( K 1 0 ) ( Set address13 in the GP internal memory )
|-----[ TO H0 H1E0 D119 K2 ]—
| ( Saves above settings to buffer memory )
|-----[ MOV K1 D149 ]—
|
|-----[ TO H0 H163 D149 K1 ]—
( GP Request Flag ON)
    
```

■ Random Read Command

Address	Contents
RWwm (H)	3: Random Read
RWwm (L)	1-14: No. of Words (W/4 occupied nodes: max. 14 points, w/3 occupied nodes: max. 10 points, w/2 occupied nodes: max. 6 points)
RWwm +1 to RWrn +F	0 to 2031: GP System Area's designated address
RWrn to RWrn +D	Reads out each piece of word data from the GP System Area's designated address.
RWrn +E to RWrn +F	Cannot be used

< Sequence Program Example > ( For random read GP memory address 100)

X6 (Data Link normal startup completed using buffer memory's parameter)

```

—| |—————[ SET M110 ]—
M110
—| |—————[ MOV K769 D119 ]—

| ( Designates 3 : Random Read(H), and 1 : no. of points(L) )
|—————[ MOV K100 D120 ]—
| ( Designates address 100 in the GP internal Memory)
|—————[ TO H0 H1E0 D119 K2 ]
| ( Saves above settings to buffer memory)
|—————[ MOV K1 D149 ]—
|
|—————[ TO H0 H163 D149 K1 ]
| (Display Request Flag ON)
|—————[ FROM H0 H2E0 D229 K1 ]—
( Saves Random Read values in device D229)
    
```

■ Continuous Write Command

Address	Contents
RWwm (H)	4: Continuous Write
RWwm (L)	1-14: No. of Words (W/4 occupied nodes: max. 14 points, w/3 occupied nodes: max. 10 points, w/2 occupied nodes: max. 6 points)
RWwm +1	0 to 2031: GP System Area's designated address
RWwm +2 to RWwm +F	Write data
RWrn to RWrn +F	Cannot be used



**Data cannot be written to the Link area.**

< Sequence Program Example > (Writes 6 words units continuously from GP memory address 2026. This example uses Write data 1,2,3,4,5 and 6.)

```

X6 (Data Link normal startup completed using buffer memory's parameter)
┌──┴──┐──────────────────────────────────────────┐ [ SET M110 ] ───┴──┐
M110
┌──┴──┐──────────────────────────────────────────┐ [ MOV K1030 D119 ] ───┴──┐
|
| (Designates 4 : Continuous Write(H), and 6 : no. of points(L) )
|──────────────────────────────────────────┐ [ MOV K2026 D120 ] ───┴──┐
| (Designates addresses in GP memory)
|──────────────────────────────────────────┐ [ MOV K1 D121 ] ───┴──┐
| (Write 1 to address 2026 in GP memory)
|──────────────────────────────────────────┐ [ MOV K2 D122 ] ───┴──┐
| (Write 2 to address 2027 in GP memory)
|──────────────────────────────────────────┐ [ MOV K3 D123 ] ───┴──┐
| (Write 3 to address 2028 in GP memory)
|──────────────────────────────────────────┐ [ MOV K4 D124 ] ───┴──┐
| (Write 4 to address 2029 in GP memory)
|──────────────────────────────────────────┐ [ MOV K5 D125 ] ───┴──┐
| (Write 5 to address 2030 in GP memory)
|──────────────────────────────────────────┐ [ MOV K6 D126 ] ───┴──┐
| (Write 6 to address 2031 in GP memory)
|──────────────────────────────────────────┐ [ MOV K1 D149 ] ───┴──┐
|
|──────────────────────────────────────────┐ [ TO H0 H1E0 D119 K8 ] ───┴──┐
| ( Saves the above settings to buffer memory)
|──────────────────────────────────────────┐ [ TO H0 H163 D149 K1 ] ───┴──┐
(Display Request Flag ON)
    
```

### ■ Random Write Command

Address	Contents
RWwm (H)	5: Random Write
RWwm (L)	1-7: No. of Words (W/4 occupied nodes: max. 7 points, w/3 occupied nodes: max. 5 points, w/2 occupied nodes: max. 3 points)
RWwm +1	0 to 2031: GP System Area's designated address
RWwm +2	Write data
-	
RWwm +D	0 to 2031: GP System Area's designated address
RWwm +E	Write data
RWwm +F	Cannot be used
RWrn to RWrn +3	Cannot be used



**Data cannot be written to the Link area.**

< Sequence Program Example > (For random writing to address 0, 1100 and 1979 in GP memory. This example uses Write data 1,2, and 3.)

X6 (Data Link normal startup completed using buffer memory's parameter)

```

— | |————— [ SET M 1 1 0 ] —
M110
— | |————— [ MOV K 1 2 8 3 D 1 1 9 ] —

| (Designates 5 : Random Write(H), and 3 : no. of points(L) )
|————— [ MOV K 0 D 1 2 0 ] —
| (Designates address 0 in GP memory)
|————— [ MOV K 1 D 1 2 1 ] —
| (Write 1 to address 0 in GP memory)
|————— [ MOV K 1 1 0 0 D 1 2 2 ] —
| (Designates address 1100 in GP memory)
|————— [ MOV K 2 D 1 2 3 ] —
| (Write 2 to address 1100 in GP memory)
|————— [ MOV K 1 9 7 9 D 1 2 4 ] —
| (Designates address 1979 in GP memory)
|————— [ MOV K 3 D 1 2 5 ] —
| (Write 3 to address 1979 in GP memory)
|————— [ T O H 0 H 1 E 0 D 1 1 9 K 7 ] —
| ( Saves above settings to buffer memory)
|————— [ MOV K 1 D 1 4 9 ] —
|
|————— [ T O H 0 H 1 6 3 D 1 4 9 K 1 ] —
(Display Request Flag ON)

```

■ Register Monitor Command

Address	Contents
RWwm (H)	6: Register Monitor
RWwm (L)	1-14: No. of Words (W/4 occupied nodes: max. 14 points, w/3 occupied nodes: max. 10 points, w/2 occupied nodes: max. 6 points)
RWwm +1 to RWwm +F	0 to 2031: GP System Area's designated address
RWrn to RWrn +F	Cannot be used

< Sequence Program Example > (When setting GP memory addresses 0, 100, 200, 1000, 1500 and 2031 for Register Monitor)

```

X6 (Data Link normal startup completed using buffer memory's parameter)
— | | ————— [ SET M110 ] —
M110
— | | ————— [ MOV H606 D119 ] —
|
| (Designates 6 : Register Monitor(H), and 6 : no. of points(L))
| ————— [ MOV K0 D120 ] —
| (Designates Address 0 in GP memory)
| ————— [ MOV K100 D121 ] —
| (Designates Address 100 in GP memory)
| ————— [ MOV K200 D122 ] —
| (Designates Address 200 in GP memory)
| ————— [ MOV K1000 D123 ] —
| (Designates Address 1000 in GP memory)
| ————— [ MOV K1500 D124 ] —
| (Designates Address 1500 in GP memory)
| ————— [ MOV K2031 D125 ] —
| (Designates Address 2031 in GP memory)
| ————— [ TO H0 H1E0 D119 K7 ] —
| (Saves above settings in buffer memory)
| ————— [ MOV K1 D149 ] —
|
| ————— [ MOV K2 D148 ] —
|
| ————— [ TO H0 H163 D149 K1 ] —
| (Display Request Flag ON)
| ————— [ FROM H0 H2E0 D229 K6 ] —
| (Saves values stored in 6 word units from D229)
M9036 (Normally ON)
— | | ————— [ FROM H0 HE3 D1000 K1 ] —
| (Saves Display Completed Flag to D1000)
• When using Monitor Request Flag (during Monitoring) refer to the Sequence Program
  Example below.
— [ = K2049 D1000 ] ————— [ TO H0 H163 D148 K1 ] —
| (When Display Complete Flag is ON) | (Display Monitor Request Flag ON)
  
```

■ Register Periodic Write Command

Address	Contents
RWwm (H)	8: Register Periodic Write
RWwm (L)	1-7: No. of Words (W/4 occupied nodes: max. 7 points, w/3 occupied nodes: max. 5 points, w/2 occupied nodes: max. 3 points)
RWwm +1 to RWwm +F	0 to 2031: GP System Area's designated address
RWrn to RWrn +F	Cannot be used



**Data cannot be written to the Link area.**

< Sequence Program Example > (When setting addresses 0, 1100 and 2031 in GP memory as Register Periodic Write)

```

— [ = K 0 D 1 0 0 0 ] ————— [ M O V   K 2 0 5 1   D 1 1 9 ] ———
|   (Designates 8 : Register Periodic Write(H), and 3 : no. of points(L) )
|   ————— [ M O V   K 0   D 1 2 0 ] ———
|   (Designate address 0 in GP memory)
|   ————— [ M O V   K 1 1 0 0   D 1 2 1 ] —
|   (Designate address 1100 in GP memory)
|   ————— [ M O V   K 2 0 3 1   D 1 2 2 ] —
|   (Designate address 2031 in GP memory)
|   ————— [ T O H 0   H 1 E 0   D 1 1 9   K 4 ] ———
|   ( Saves above settings in buffer memory)
|   ————— [ M O V   K 1   D 1 4 9 ] ———
|
|   ————— [ M O V   K 4   D 1 4 8 ] ———
|
|   ————— [ T O H 0   H 1 6 3   D 1 4 9   K 1 ] —
|
|                                     (Display Request Flag ON)
    
```

```

M 9 0 3 6 (Normally ON)
— | | ————— [ F R O M   H 0   H E 3   D 1 0 0 0   K 1 ] ———
|                                     (Saves buffer contents <Display Complete Flag> to D1000)
    
```

```

— [ = K 2 0 4 9   D 1 0 0 0 ] ————— [ T O H 0   H 1 6 3   D 1 4 8   K 1 ] ———
|                                     ( When Display Complete Flag is ON)   (Display Periodic Write Request Flag ON)
    
```

```

M 9 0 3 6 (Normally ON)
— | | ————— [ T O H 0   H 1 E 0   D 1 1 9   K 1 ] ———
|                                     (Data will be written in periodically when a value is input to D119)
    
```



**Note:** For further information about the ladder program and settings, please refer to Mitsubishi's “AJ61BT11/A1SJ61BT11 type CC-Link System Master Local Unit Users Manual (Details)” or “AJ61QBT11/A1SJ61QBT11 type CC-Link System Master Local Unit Users Manual (Details)”



**9.2.5 Occupied Node**

■ 2 Nodes Occupied

LS area (Word Address)	Bit	Signal	Detail
a to a+2	0 to F	RXm0 to RX mF to RX (m+2)0 to RX (m+2)F	User's Area (RX) : 3words occupied (When 2 nodes are occupied)
<div style="display: flex; flex-direction: column; align-items: center;"> <div style="margin-bottom: 5px;">0</div> <div style="margin-bottom: 5px;">19</div> <div style="margin-bottom: 5px;">a</div> <div style="margin-bottom: 5px;">a+7</div> <div style="margin-bottom: 5px;">a+8</div> <div style="margin-bottom: 5px;">a+51</div> <div style="margin-bottom: 5px;">a+52</div> <div style="margin-bottom: 5px;">2031</div> </div> <div style="display: flex; flex-direction: column; align-items: center; width: 100%;"> <div style="margin-bottom: 5px;">System Data Area</div> <div style="margin-bottom: 5px;">Link Area (a to a+7)</div> <div style="margin-bottom: 5px;">Link Area (a+8 ~ a+51)</div> <div style="margin-bottom: 5px;">User Area (a+52 ~ 2031)</div> </div>	0	RX(m+n)0	Display Complete Flag
	1	RX(m+n)1	Reserved
	2	RX(m+n)2	Reserved
	3	RX(m+n)3	Reserved
	4	RX(m+n)4	Reserved
	5	RX(m+n)5	Touch ON Complete Flag
	6	RX(m+n)6	Reserved
	7	RX(m+n)7	Tag Code Read Out Request Flag
	8	RX(m+n)8	Reserved
	9	RX(m+n)9	Initial Data Setting Completed Flag
	10	RX(m+n)A	Error Flag
	11	RX(m+n)B	Remote READY
	12	RX(m+n)C	Reserved
	13	RX(m+n)D	Reserved
	14	RX(m+n)E	Reserved
	15	RX(m+n)F	Reserved
a+4 to a+7		Not used	
a+8		Reserved	
a+9		Reserved	
a+10 to a+12	0 to F	RYm0 to RY mF to RY (m+2)0 to RY (m+2)F	User's Area (RY) : 3words occupied (When 2 nodes are occupied)
	0	RY(m+n)0	Display Request Flag
	1	RY(m+n)1	Display Monitor Request Flag
	2	RY(m+n)2	Display Periodic Write Request Flag
	3	RY(m+n)3	Reserved
	4	RY(m+n)4	Reserved
	5	RY(m+n)5	Reserved
	6	RY(m+n)6	Reserved
	7	RY(m+n)7	Reserved
	8	RY(m+n)8	Reserved
	9	RY(m+n)9	Initial Data Setting Request Flag
	10	RY(m+n)A	Error Reset Request Flag
	11	RY(m+n)B	Reserved
	12	RY(m+n)C	Reserved
	13	RY(m+n)D	Reserved
	14	RY(m+n)E	Reserved
	15	RY(m+n)F	Reserved
a+14 to a+17		Not used	
a+18		Reserved	
a+19		Reserved	
a+20 to a+27		Rwr	Rwr (R to M) during ordinary monitoring
a+28 to a+35		Not used	
a+36 to a+43		RWw	RWw (M to R) during ordinary monitoring
a+44 to a+51		Not used	



- Shaded areas  are used when 2 to 4 nodes are used on common.
- “a” means a Start Address.( a<sup>3</sup> 20)
- “System area” is used for writing GP display switching data/ error data. The type of data written is defined in each address. The contents of this area are the same as the Memory Link Type.

**Reference** Digital’s Memory Link Communication “Contents and Range of System Data Area”.

■ 3 Nodes Occupied

		LS area (Word Device)	Bit	Signal	Contents
0 19 a a+7 a+8 a+51 a+52 2031	System Data Area	a to a+4	0 to F	RXm0 to RX mF to RX (m+4)0 to RX (m+4)F	User's Area (RX) : 5 words occupied (When 3 nodes are occupied)
		Link Area (a to a+7) Link Area (a+8 ~ a+51) User Area (a+52 ~ 2031)	a+5	0	RX(m+n)0
	1		RX(m+n)1	Reserved	
	2		RX(m+n)2	Reserved	
	3		RX(m+n)3	Reserved	
	4		RX(m+n)4	Reserved	
	5		RX(m+n)5	Touch ON Complete Flag	
	6		RX(m+n)6	Reserved	
	7		RX(m+n)7	Tag Code Read Out Request Flag	
	8		RX(m+n)8	Reserved	
	9		RX(m+n)9	Initial Data Setting Completed Flag	
	10		RX(m+n)A	Error Flag	
	11		RX(m+n)B	Remote READY	
	12		RX(m+n)C	Reserved	
	13		RX(m+n)D	Reserved	
	14		RX(m+n)E	Reserved	
15	RX(m+n)F	Reserved			
	a+6 to a+7		Not used		
	a+8		Reserved		
	a+9		Reserved		
	a+10 to a+14	0 to F	RYm0 to RY mF to RY (m+4)0 to RY (m+4)F	User's Area (RY) : 5 words occupied (When 3 nodes are occupied)	
	a+15	0	RX(m+n)0	Display Request Flag	
		1	RX(m+n)1	Display Monitor Request Flag	
		2	RX(m+n)2	Display Periodic Write Request Flag	
		3	RX(m+n)3	Reserved	
		4	RX(m+n)4	Reserved	
		5	RX(m+n)5	Reserved	
		6	RX(m+n)6	Reserved	
		7	RX(m+n)7	Reserved	
		8	RX(m+n)8	Reserved	
		9	RX(m+n)9	Initial Data Setting Request Flag	
		10	RX(m+n)A	Error Reset Request Flag	
		11	RX(m+n)B	Reserved	
		12	RX(m+n)C	Reserved	
		13	RX(m+n)D	Reserved	
		14	RX(m+n)E	Reserved	
		15	RX(m+n)F	Reserved	
	a+16 to a+17		Not used		
	a+18		Reserved		
	a+19		Reserved		
	a+20 to a+31		RWr	Rw r (R to M) during ordinary monitoring	
	a+32 to a+35		Not used		
	a+36 to a+47		RWw	RWw (M to R) during ordinary monitoring	
	a+48 to a+51		Not used		



- Shaded areas  are used when 2 to 4 nodes are used on common.
- “a” means a Start Address.( a<sup>3</sup> 20)
- “System area” is used for writing GP display switching data/ error data. The type of data written is defined in each address. The contents of this area are the same as the Memory Link Type. **Reference** *Digital's Memory Link Communication “Contents and Range of System Data Area”*.

■4 Nodes Occupied

LS area (Word Device)	Bit	Signal	Contents	
<div style="border: 1px solid black; padding: 5px; width: fit-content;">                     System Data Area                      0                      19                      a                      Link Area (a to a+7)                      a+7                      a+8                      Link Area (a+8 ~ a+51)                      a+51                      a+52                      User Area (a+52 ~ 2031)                      2031                 </div>	a to a+6	0 to F	RXm0 to RX mF to RX (m+6)0 to RX (m+6)F User's Area (RX) : 7 words occupied (When 4 nodes are occupied)	
	a+7	0	RX(m+n)0	Display Complete Flag
		1	RX(m+n)1	Reserved
		2	RX(m+n)2	Reserved
		3	RX(m+n)3	Reserved
		4	RX(m+n)4	Reserved
		5	RX(m+n)5	Touch ON Complete Flag
		6	RX(m+n)6	Reserved
		7	RX(m+n)7	Tag Code Read Out Request Flag
		8	RX(m+n)8	Reserved
		9	RX(m+n)9	Initial Data Setting Completed Flag
		10	RX(m+n)A	Error Flag
		11	RX(m+n)B	Remote READY
		12	RX(m+n)C	Reserved
		13	RX(m+n)D	Reserved
		14	RX(m+n)E	Reserved
	15	RX(m+n)F	Reserved	
a+8			Reserved	
a+9			Reserved	
a+10 to a+16	0 to F	RYm0 to RY mF to RY (m+6)0 to RY (m+6)F	User's Area (RY) : 7 words occupied (When 4 nodes are occupied)	
a+17	0	RX(m+n)0	Display Request Flag	
	1	RX(m+n)1	Display Monitor Request Flag	
	2	RX(m+n)2	Display Periodic Write Request Flag	
	3	RX(m+n)3	Reserved	
	4	RX(m+n)4	Reserved	
	5	RX(m+n)5	Reserved	
	6	RX(m+n)6	Reserved	
	7	RX(m+n)7	Reserved	
	8	RX(m+n)8	Reserved	
	9	RX(m+n)9	Initial Data Setting Request Flag	
	10	RX(m+n)A	Error Reset Request Flag	
	11	RX(m+n)B	Reserved	
	12	RX(m+n)C	Reserved	
	13	RX(m+n)D	Reserved	
	14	RX(m+n)E	Reserved	
	15	RX(m+n)F	Reserved	
a+18			Reserved	
a+19			Reserved	
a+20 to a+35		RWr	Rwr (R to M) during ordinary monitoring	
a+36 to a+51		RWw	RWw (M to R) during ordinary monitoring	



- Shaded areas  are used when 2 to 4 nodes are used on common.
- “a” means a Start Address.( a<sup>3</sup> 20)
- “System area” is used for writing GP display switching data/ error data. The type of data written is defined in each address. The contents of this area are the same as the Memory Link Type. **Reference** *Digital's Memory Link Communication "Contents and Range of System Data Area"*.

### 9.2.6 Error Code

The following list shows the error codes used with CC-Link. These error codes will appear on the screen as, for example, “PLC COM. ERROR, (02: \*\*)”, where \*\* stands for an error code listed below.

Error Code (**)	Error Details
01	Designated device point is not within the limited range
02	Designated address is not within the limited range
03	Command is not defined
04	Incorrect initial command is designated.(Do not use the Request Flag for initial
05	Undefined mode is designated for initial command
06	Not registered in Monitor Command
07	Not registered in Periodic Write Command
08	Data attempted to be written in the write prohibited system area
09	In the OFFLINE mode now
14	No Reply from Hardware
15	Problem in Hardware
16	Node Number switch setting error
17	Baud Rate Switch setting error
18	Set up Node Number switch change error
19	Set up Baud Rate switch change error
1A	CRC error
1B	Time over error
1C	0 channel carrier detection error
1D	1 channel carrier detection error
1E	Communication Transfer error
1F	Y data or RWr data, numerical error
20	Y data, numerical error
21	RWr data, numerical error



**Note:**

**If a command error occurs while exclusive command monitor is used, the GP will automatically set the error codes above in RWr, then turn ON the Error Status Flag “RX(m+n)A” and the Display Complete Flag “RX(m+n)0” .**

#### ◆ Troubleshooting

GP Error Display (bottom left corner)	Status
PLC COM.ERROR (02:14)	PLC's power supply turned off during normal communication
PLC COM.ERROR (02:14)	Cable between PLC and GP is not properly connected
PLC COM.ERROR (02:15)	GP's rear unit is not attached
PLC COM.ERROR (02:15)	GP's rear unit is not properly attached
PLC COM.ERROR (02:14)	GP is not registered in the current parameters.
PLC COM.ERROR (02:14)	Baud Rate is not applicable
PLC COM.ERROR (02:14)	Node number is duplicated.
PLC COM.ERROR (02:1A) Blinking	Terminating resistor is not connected