



FX Shot

ORDERCODE 60908



Highlite International B.V.
Vestastraat 2
6468 EX Kerkrade
The Netherlands
Phone: +31 45-5667700

SHOWELECTRONICS FOR PROFESSIONALS

Congratulations!

You have bought a great, innovative product from Showtec.

The Showtec FX Shot brings excitement to any venue. Whether you want simple plug-&-play action or a sophisticated DMX show, this product provides the effect you need.

You can rely on Showtec, for more excellent lighting products.

We design and manufacture professional light equipment for the entertainment industry.

New products are being launched regularly. We work hard to keep you, our customer, satisfied.

For more information: iwant@showtec.info

You can get some of the best quality, best priced products on the market from Showtec.

So next time, turn to Showtec for more great lighting equipment.

Always get the best -- with Showtec !

Thank you!



Showtec FX Shot™ Product Guide

Warning2
 Safety Instructions2
 Operating Determinations4
 Rigging4
 Return Procedure5
 Claims.....5

Description of the device.....6
 Overview6
 Accessories7

Installation.....8

Testing.....10

Set Up and Operation.....10

Disconnection11

Maintenance12

Troubleshooting12
 No Light12
 No Response to DMX from your controller.....12

Product Specification13

Warning

**FOR YOUR OWN SAFETY, PLEASE READ THIS USER MANUAL CAREFULLY
BEFORE YOUR INITIAL START-UP!**

Unpacking Instructions

Immediately upon receiving this product, carefully unpack the carton and check the contents to ensure that all parts are present, and have been received in good condition. Notify the dealer immediately and retain packing material for inspection if any parts appear damaged from shipping or the carton itself shows signs of mishandling. Save the carton and all packing materials. In the event that a fixture must be returned to the factory, it is important that the fixture be returned in the original factory box and packing.

Your shipment includes:

- Showtec FX Shot with IEC powercable 1,50m
- User manual



CAUTION!

**Keep this device away from rain and moisture!
Unplug mains lead before opening the housing!**



Safety Instructions

Every person involved with the installation, operation and maintenance of this device has to:

- be qualified
- follow the instructions of this manual



**CAUTION! Be careful with your operations.
With a dangerous voltage you can suffer
a dangerous electric shock when touching the wires!**



Before your initial start-up, please make sure that there is no damage caused by transportation. Should there be any, consult your dealer and do not use the device.

To maintain perfect condition and to ensure a safe operation, it is absolutely necessary for the user to follow the safety instructions and warning notes written in this manual.

Please consider that damages caused by manual modifications to the device are not subject to warranty.

This device contains no user-serviceable parts. Refer servicing to qualified technicians only.

You, your employees and others who use or come into contact with the FX Shot must be aware how the machine should be handled. This includes the proper use, maintenance and repair of the machine as described in this manual. This also means that employees are familiar with the use of machinery through training or experience.

IMPORTANT:

The manufacturer will not accept liability for any resulting damages caused by the non-observance of this manual or any unauthorized modification to the device.

- Never let the power-cord come into contact with other cables! Handle the power-cord and all connections with the mains with particular caution!
- Never remove warning or informative labels from the unit. The operator should regularly check.
- The operator must make sure that the texts are always clearly visible, legible and remain.
- If text and/or icons are missing, damaged or illegible on the FX Shot, they should be replaced.
- Do not open the device and do not modify the device.
- Never use anything to cover the ground contact.
- Never look directly into the FX Shot.
- Never leave any cables lying around.
- Never replace parts yourselves.
- Never remove or deactivate safety devices.
- All required safety equipment must be in good condition and must be working properly.
- Do not insert objects into air vents.
- Do not switch the device on and off in short intervals, as this would reduce the device's life.
- Do not shake the device. Avoid brute force when installing or operating the device. The FX Shot reacts very sensitive to movement.
- Do not touch the FX Shot while working or if it is connected to the mains power. Even if the FX Shot is not in operation, the electric cannons can still be filled and cause harm.
- Do not place the FX Shot in the vicinity of a vibration source.
- Never use the device during thunderstorms, unplug the device immediately.
- Only use device indoor, avoid contact with water or other liquids.
- Only operate the device after having familiarized with its functions.
- Only use the FX Shot according to the instructions in this manual
- Avoid flames and do not put close to flammable liquids or gases.
- Always allow free air space of at least 50 cm around the unit for ventilation.
- Always disconnect power from the mains, when device is not used or before cleaning! Only handle the power-cord by the plug. Never pull out the plug by tugging the power-cord.
- Always keep the workplace clean and provide adequate ambient lighting.
- Make sure that the device is not exposed to extreme heat, moisture or dust.
- Make sure that the available voltage is not higher than stated on the rear panel.
- Make sure that the power-cord is never crimped or damaged. Check the device and the power-cord from time to time.
- If the external cable is damaged, it has to be replaced by a qualified technician.
- If device is dropped or struck, disconnect mains power supply immediately. Have a qualified engineer inspect for safety before operating.
- If the device has been exposed to drastic temperature fluctuation (e.g. after transportation), do not switch it on immediately. The arising condensation water might damage your device. Leave the device switched off until it has reached room temperature.
- If your Showtec device fails to work properly, discontinue use immediately. Pack the unit securely (preferably in the original packing material), and return it to your Showtec dealer for service.
- For adult use only. FX Shot must be installed out of the reach of children. Never leave the unit running unattended.
- The FX Shot may only be used if there are no persons, animals or other objects in the direct "line of fire" of the electric cannon within the output distance. The shooting direction is the direction, in which the electric cannon of the FX Shot is pointing. The output distance is dependent on the content and length of the electric cannons.
- Showtec is not liable for the damages caused by faults on the FX Shot.
- The user is responsible for correct positioning and operating of the FX Shot. The manufacturer will not accept liability for unsafe situations, accidents, damages caused by:
 - The misuse or incorrect installation of this device.
 - Ignoring warnings or instructions as shown in this manual.
 - Using the FX Shot for purposes or conditions other than specified in this manual.
 - Changes to the FX Shot. This includes the use of other than original spare parts.
 - Inadequate maintenance.
 - The unauthorized removal of safety covers and / or guards.
 - The improper use of the FX Shot.
- This device falls under protection class I. Therefore it is essential to connect the yellow/green conductor to earth.
- Repairs, servicing and electric connection must be carried out by a qualified technician.
- WARRANTY: Till one year after date of purchase.

Operating Determinations

- This device is not designed for permanent operation. Consistent operation breaks will ensure that the device will serve you for a long time without defects.
- The maximum ambient temperature $t_a = 45^\circ\text{C}$ must never be exceeded.
- The relative humidity must not exceed 50 % with an ambient temperature of 45°C .
- If this device is operated in any other way, than the one described in this manual, the product may suffer damages and the warranty becomes void.
- Any other operation may lead to dangers like short-circuit, burns, electric shock, crash etc.

You endanger your own safety and the safety of others!

Rigging

Please follow the European and national guidelines concerning rigging, trussing and all other safety issues.

Do not attempt the installation yourself !

Always let the installation be carried out by an authorized dealer !

Procedure:

- If the FX Shot is lowered from the ceiling or high joists, professional trussing systems have to be used.
- Use a clamp to mount the FX Shot, with the mounting-bracket, to the trussing system.
- The FX Shot must never be fixed swinging freely in the room.
- The installation must always be secured with a safety attachment, e.g. an appropriate safety net or safety-cable.
- When rigging, derigging or servicing the device, always make sure, that the area below the installation place is blocked and staying in the area is forbidden.

Improper installation can cause serious damage to people and property !

Connection with the mains

Connect the device to the mains with the power-plug.

Always pay attention, that the right color cable is connected to the right place.

International	EU Cable	UK Cable	US Cable	Pin
L	BROWN	RED	YELLOW/COPPER	PHASE
N	BLUE	BLACK	SILVER	NULL
	YELLOW/GREEN	GREEN	GREEN	EARTH

Make sure that the device is always connected properly to the earth!



Return Procedure

Returned merchandise must be sent prepaid and in the original packing, call tags will not be issued. Package must be clearly labeled with a Return Authorization Number (RMA number). Products returned without an RMA number will be refused. Highlite will not accept the returned goods or any responsibility. Call Highlite 0031-455667723 or mail aftersales@highlite.nl and request an RMA prior to shipping the fixture. Be prepared to provide the model number, serial number and a brief description of the cause for the return. Be sure to properly pack fixture, any shipping damage resulting from inadequate packaging is the customer's responsibility. Highlite reserves the right to use its own discretion to repair or replace product(s). As a suggestion, proper UPS packing or double-boxing is always a safe method to use.

Note: If you are given an RMA number, please include the following information on a piece of paper inside the box:

- 1) Your name
- 2) Your address
- 3) Your phone number
- 4) A brief description of the symptoms

Claims

The client has the obligation to check the delivered goods immediately upon delivery for any shortcomings and/or visible defects, or perform this check after our announcement that the goods are at their disposal. Damage incurred in shipping is the responsibility of the shipper; therefore the damage must be reported to the carrier upon receipt of merchandise.

It is the customer's responsibility to notify and submit claims with the shipper in the event that a fixture is damaged due to shipping. Transportation damage has to be reported to us within one day after receipt of the delivery.

Any return shipment has to be made post-paid at all times. Return shipments must be accompanied with a letter defining the reason for return shipment. Non-prepaid return shipments will be refused, unless otherwise agreed in writing.

Complaints against us must be made known in writing or by fax within 10 working days after receipt of the invoice. After this period complaints will not be handled anymore.

Complaints will only then be considered if the client has so far complied with all parts of the agreement, regardless of the agreement of which the obligation is resulting.

Description of the device

Features

The Showtec FX Shot is an easy-to-use electric confetti shooter with great effects.

- Designed to fire prefilled single use electric cannons, which are available in 40cm and 80cm
- Specifically designed for from a stage or from a truss and easily controlled electric cannons to shoot
- The FX Shot can be used both with electric confetti cannons as with electric streamer cannons
- Confetti or streamers in various colors, even Fluor, UV and metallic colors are an option
- The cannons contain a pressurized nitrogen cartridge which launches confetti up to 12 meters and streamers even 20 meters wide
- Suited for 40cm and 80cm shooters
- Plug-and-play
- Powersupply: 240V / 50-60 Hz
- Peak Power: 100W
- Indoor use
- Operation: 230V on/off or DMX controlled by using a Multidim, Multiswitch or Relay Pack (see p.9+11)
- FX Shot will be activated by a 230V power source and can therefore be operated by a 230V power switch like the Showtec DJ-Switch (50363) see page 11
- Fuse: Circuit Protection
- Dimensions: 150 x 145 x 166 mm (LxWxH)
- Weight: 1,7 kg without cannon

Optional Accessories

[60907](#) FX Shot base plate for 1,2 or 4

[60909](#) FX Shot Cannon clamp with certified safety cable

[70332](#) Twenty Clamp SWL20 kg, TÜV 28 mm

 These accessories are essential when using the FX shot safely. 

Overview

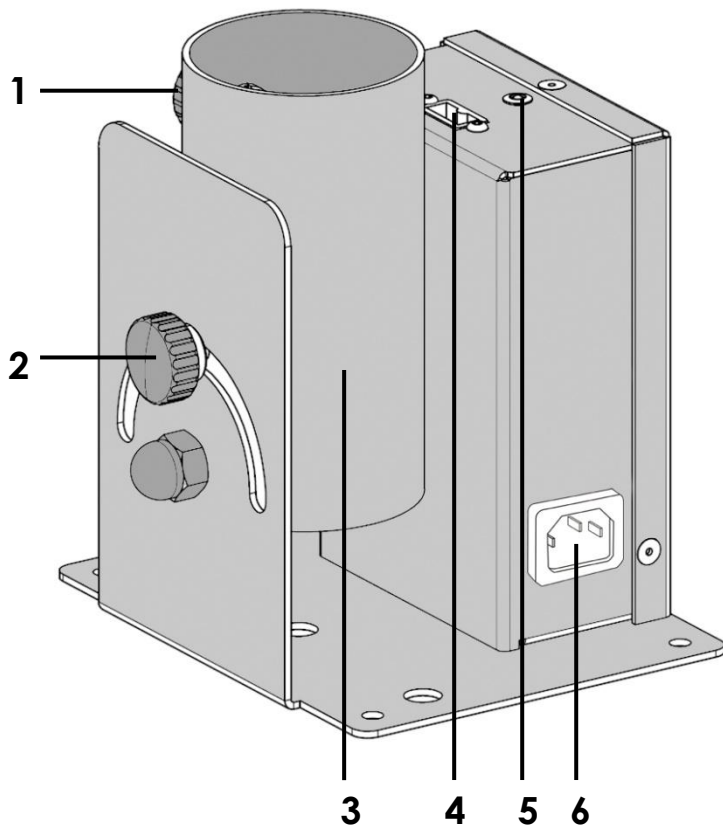

Fig. 3

- 1) Cannon Screw
- 2) Inclination Screw
- 3) Cannon Tube

- 4) Cannon Ignition connector
- 5) LED indicator
- 6) IEC Power connector

Accessories

		
60909 – Cannon clamp with safety cable	70332 – Twenty Clamp SWL 20 kg, TÜV 28 mm	60907 – Base Plate for 1, 2 or 4 FX Shots







The FX Shot only works with approved electric confetti and streamer cannons. The FX Shot is not suitable for other than the 40 and 80mm cannons shown below.



		
40cm Electric cannon	80cm Electric cannon	Other confetti cannons

The following types of electric cannons can be used:

Type Cannon	Contents	Cannon Length	Output
	CONFETTI (150g)	40cm	5m.
	STREAMERS (150g)	40cm	12m.
	CONFETTI (300g)	80cm	12m.
	STREAMERS (300g)	80cm	20m.

Installation

- 1) Place the FX Shot on a flat, stable surface and secure it. It is possible to install 1, 2, or 4 FX Shots on the base plate.



- 2) If the FX Shot is mounted onto a truss system, install 2 certified truss clamps (70332) at the bottom of the FX Shot.

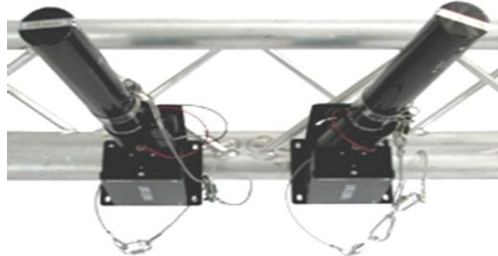

- 3) Place the FX Shot in the desired position on the truss system and tighten the clamps securely.
- 4) Always use a safety cable to secure the FX Shot to the truss system.
- 5) You cannot link multiple FX Shots together via IEC IN - IEC OUT. You have to connect them separately to AC power. You can connect multiple shooters via one Schuko connection.



Schuko to 2 IEC splitter ([90442](#)) Length: 3 m



Schuko to 3 IEC splitter ([90443](#)) Length: 3 m

- 6) Place an electric cannon in the cannon holder.

⚠ Do not connect the Ignition connector!! ⚠

As a result of the pressure, which is released during the shooting of confetti, the electric cannon can come loose from the FX Shot.



Always use a Cannon Clamp ([60909](#)) to secure the electric cannon to the FX Shot. Also use a Cannon Clamp ([70332](#)) when attaching the FX Shot onto a truss system.



7) Fix the electric cannon to the pivot clamp by turning the fixation screw on the side of the holder.



⚠ Turn the screws snugly. Never turn the rotary clamp tighter than necessary. **⚠**
 Otherwise this may cause damages to the pressure pattern in the electric cannon.

8) Once the electric cannon is placed inside the FX Shot, it can be set to the correct shooting direction. On the side of the FX Shot is an inclination screw, which can be turned to position the holder in the right direction.



⚠ Never shoot directly towards people, animals or objects. **⚠**
 Also refer to this manual for the correct shooting distance of several cannons.

9) If you want to operate **multiple** shooters via DMX, use a Multidim, Multiswitch or Relay Pack to operate the FX Shot.

[50386](#)-MultiDim MKII



[50357](#)-MultiSwitch



[50752](#)-RP-405 Relay Pack





10) If you want to operate **one** shooter via DMX, use a Single MKII ([50396](#)) to operate the FX Shot.



Make sure you always have an eye on the FX Shot, when you are operating the Multidim, Multiswitch, Relay Pack or Single MKII.



Testing

When testing, make sure that no electric cannons are connected via the ignition plug to the FX Shot.

- 1) Test the operation of the FX Shot by connecting the IEC cable to the mains power supply. Once the blue LED above the FX Shot lights up, you know that the FX Shot is properly connected.
- 2) For DMX Operation also check if the blue LED lights up when activating/engaging your specific DMX setup or DJ switch setup work.



Make sure that after testing, you disengage the switchpack. The blue LED must be off.



- 3) Carefully plug the electric cannon ignition connector into the input on top of the FX Shot. This connector has a recess, so that the plug can only be plugged into the socket one way.



ONLY connect the ignition plug when the blue LED is OFF !!!



Be careful: Always look before plugging the connector into the socket.

If the blue LED is on, immediately stop. Disconnect the FX Shot from the mains power supply and check your setup. If the blue LED is lit, then the cannon can shoot off its confetti, when the connector is put into the socket.



Set Up and Operation

Before plugging the unit in, always make sure that the power supply matches the product specification voltage. Do not attempt to operate a 120V specification product on 230V power, or vice versa.

Remove all packing materials from the FX Shot. Check that all foam and plastic padding is removed.

Always disconnect from electric mains power supply before cleaning or servicing.

Damages caused by non-observance are not subject to warranty.



The FX Shot only works with approved electric confetti and streamer cannons. The FX Shot is not suitable for other than the 40 and 80mm cannons shown below.



All pre-filled cannons are destined to be used only once !!!

Metallic products have a slightly heavier weight and will therefore achieve greater output.

The electric cannons contain pressure holders so the confetti / streamers blows the confetti away with a lot of pressure. Always keep a free shooting range.

The FX Shot may only be operated by adult and competent persons.

The FX Shot may only be operated when all components are completely and correctly installed / connected.

Use caution when operating the FX Shot:

When the FX Shot is connected to the mains power supply, the connected electrical cannon will shoot. Make sure you only shoot the FX Shot when no persons, animals or objects are in the path of the cannon.

SETUP 1

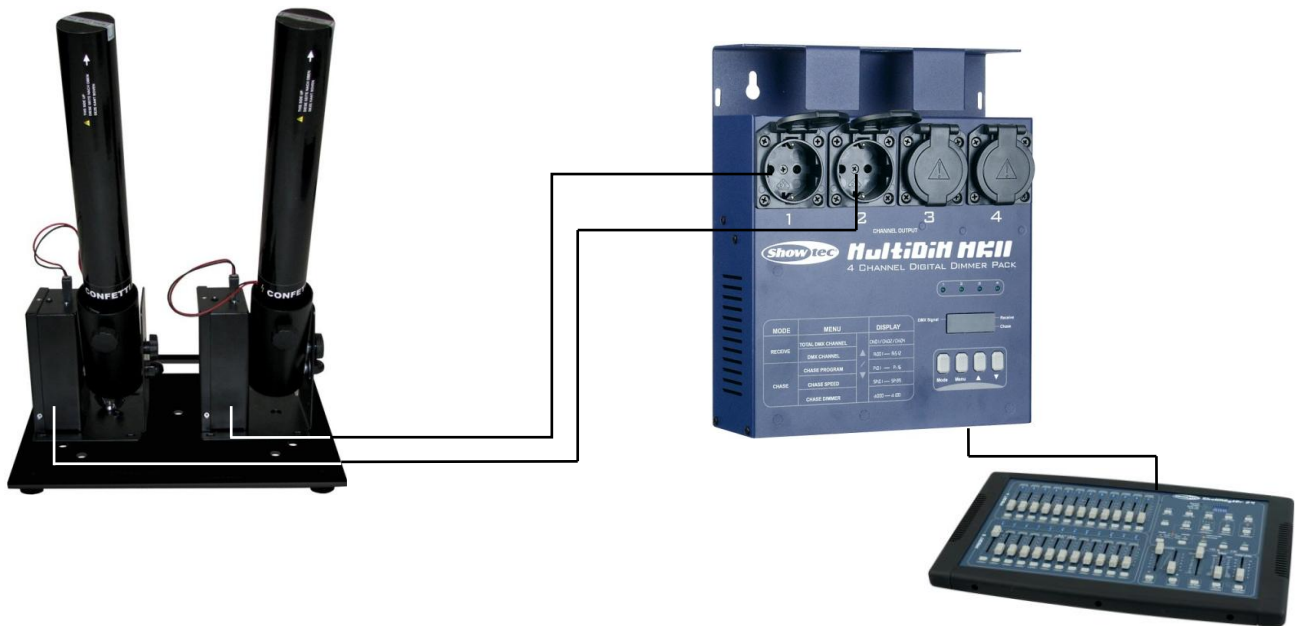

[50335](#) Showmaster 24
Or use a [50317](#) SB-16



SETUP 2

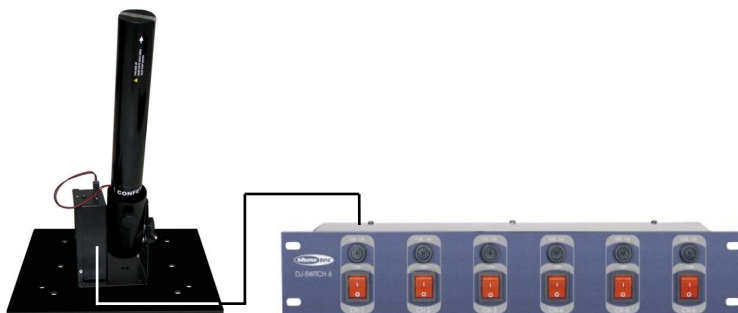

[50363](#) DJ-Switch 6

Disconnection

- 1) Disconnect the FX Shot from the power, make sure it is no longer connected to a voltage source.
- 2) Remove the IEC cable.
- 3) Remove the cannon from the FX Shot.



Maintenance

The Showtec FX Shot requires almost no maintenance. However, you should keep the unit clean. Otherwise, the fixture's light-output will be significantly reduced. Disconnect the mains power supply, and then wipe the cover with a damp cloth. Do not immerse in liquid. Wipe lens clean with glass cleaner and a soft cloth. Do not use alcohol or solvents. Keep connections clean. Disconnect electric power, and then wipe the connections with a damp cloth. Make sure connections are thoroughly dry before linking equipment or supplying electric power.

The operator has to make sure that safety-relating and machine-technical installations are to be inspected by an expert after every four years in the course of an acceptance test.

The operator has to make sure that safety-relating and machine-technical installations are to be inspected by a skilled person once a year.

The following points have to be considered during the inspection:

1. All screws used for installing the device or parts of the device have to be tightly connected and must not be corroded.
2. There may not be any deformations on housings, fixations and installation spots.
3. Mechanically moving parts like axles, eyes and others may not show any traces of wearing.
4. The electric power supply cables must not show any damages or material fatigue.

Troubleshooting

No blue LED Indicator

This troubleshooting guide is meant to help solve simple problems.

If a problem occurs, carry out the steps below in sequence until a solution is found. Once the unit operates properly, do not carry out following steps.

If the light effect does not operate properly, refer servicing to a technician.

Response: Suspect two potential problem areas: the power supply or the IEC cable.

- 1) Power supply. Check that the unit is plugged into an appropriate power supply.
- 2) Check that the IEC cable is properly connected and that the cable is not defective.
- 3) If all of the above appears to be O.K., plug the unit in again.
- 4) If you are unable to determine the cause of the problem, do not open the FX Shot, as this may damage the unit and the warranty will become void.
- 5) Follow the steps below. If that doesn't work return the device to your Showtec dealer.

A cannon does not fire

First turn off the power to the FX Shot and then walk towards the FX Shot.

Make sure the connector is properly connected to the cannon. If the blue LED indicator is lit and the cannon does not fire, switch the cannon for another and see if it does fire.

The FX Shot does not work even after checking the troubleshooting

If you are not clear about the operation of the FX Shot or other matters relating to the FX Shot always contact your dealer.

No Response to DMX from your controller

Response: Suspect the DMX cable or connectors, a controller malfunction, a light effect DMX card malfunction.

1. Check the DMX setting. Make sure that DMX addresses are correct.
2. Check the DMX cable: Unplug the unit; change the DMX cable; then reconnect to electrical power. Try your DMX control again.
3. Determine whether the controller or light effect is at fault. Does the controller operate properly with other DMX products? If not, take the controller in for repair. If so, take the DMX cable and the light effect to a qualified technician.

Product Specification

Model: Showtec FX Shot

- Designed to fire prefilled single use electric cannons, which are available in 40cm and 80cm
- Specifically designed for from a stage or from a truss and easily controlled electric cannons to shoot
- The FX Shot can be used both with electric confetti cannons as with electric streamer cannons
- Confetti or streamers in various colors, even Fluor, UV and metallic colors are an option
- The cannons contain a pressurized nitrogen cartridge which launches confetti up to 12 meters and streamers even 20 meters wide
- Suited for 40cm and 80cm shooters
- Plug-and-play
- Powersupply: 240V / 50-60 Hz
- Peak Power: 100W
- Indoor use
- Operation: 230V on/off or DMX controlled by using a Multidim, Multiswitch or Relay Pack (see p.9+11)
- FX Shot will be activated by a 230V power source and can therefore be operated by a 230V power switch like the Showtec DJ-Switch (50363) see page 11
- Fuse: Circuit Protection
- Dimensions: 150 x 145 x 166 mm (LxWxH)
- Weight: 1,7 kg without cannon



Optional Accessories

[60907](#) FX Shot base plate for 1,2 or 4

[60909](#) FX Shot Cannon clamp with certified safety cable

[70332](#) Twenty Clamp SWL20 kg, TÜV 28 mm



These accessories are essential when using the FX shot safely.



Minimum distance:

Minimum distance from flammable surfaces: 0.5m

Minimum distance to lighted object: 0.8m

Design and product specifications are subject to change without prior notice.



Website: www.Showtec.info

Email: service@highlite.nl



© 2012 Showtec.