

Digital Output Module

ST-2xxx User Manual



Version 1.02

2012 CREVIS Co.,Ltd

DOCUMENT CHANGE SUMMARY				
REV	PAGE	REMARKS	DATE	EDITOR
1.0	New Document		2011/10/07	JE KANG
1.01		2944, 2734 Image Revision	2011/10/28	JE KANG
1.02	6	Add your experience	2012/1/13	JE KANG

Table of Contents

1. Important Notes	6
1.1. Safety Instruction	6
1.1.1. Symbols	7
1.1.2. Safety Notes	7
1.1.3. Certification	7
2. DIGITAL OUTPUT MODULE LIST	8
3. Specification	9
3.1. The Interface	9
3.1.1. ST-2114	9
3.1.2. ST-2124	10
3.1.3. ST-221F	11
3.1.4. ST-222F	12
3.1.5. ST-2314	13
3.1.6. ST-2318	14
3.1.7. ST-2324	15
3.1.8. ST-2328	16
3.1.9. ST-2414	17
3.1.10. ST-2424	18
3.1.11. ST-2514	19
3.1.12. ST-2524	20
3.1.13. ST-2614	21
3.1.14. ST-2624	22

3.1.15. ST-2742.....	23
3.1.16. ST-2744.....	24
3.1.17. ST-2748.....	25
3.1.18. ST-2792.....	26
3.1.19. ST-2852.....	27
3.1.20. ST-2924.....	28
3.1.21. ST-2944.....	29
3.1.22. ST-2734.....	30
3.2. Environment Specification	31
3.3. Specification	32
3.3.1. ST-2114.....	32
3.3.2. ST-2124.....	33
3.3.3. ST-221F.....	34
3.3.4. ST-222F.....	35
3.3.5. ST-2314.....	36
3.3.6. ST-2318.....	37
3.3.7. ST-2324.....	38
3.3.8. ST-2328.....	39
3.3.9. ST-2414.....	40
3.3.10. ST-2424.....	41
3.3.11. ST-2514.....	42
3.3.12. ST-2524.....	43
3.3.13. ST-2614.....	44

3.3.14. ST-2624.....	45
3.3.15. ST-2742.....	46
3.3.16. ST-2744.....	47
3.3.17. ST-2748.....	48
3.3.18. ST-2792.....	49
3.3.19. ST-2852.....	50
3.3.20. ST-2924.....	51
3.3.21. ST-2944.....	52
3.3.22. ST-2734.....	53
4. Dimension.....	54
4.1. ST-2xx2, ST-2xx4, ST-2xx8.....	54
4.2. ST-2xxF	55
5. Mapping Data into the image Table.....	56
5.1. ST-2742, ST-2852	56
5.2. ST-2xx4	56
5.3. ST-2xx8	56
5.4. ST-2xxF	57
6. Trouble Shooting	58

1. Important Notes

Solid state equipment has operational characteristics differing from those of electromechanical equipment.

Safety Guidelines for the Application, Installation and Maintenance of Solid State Controls describes some important differences between solid state equipment and hard-wired electromechanical devices.

Because of this difference, and also because of the wide variety of uses for solid state equipment, all persons responsible for applying this equipment must satisfy themselves that each intended application of this equipment is acceptable.

In no event will CREVIS be responsible or liable for indirect or consequential damages resulting from the use or application of this equipment.

The examples and diagrams in this manual are included solely for illustrative purposes. Because of the many variables and requirements associated with any particular installation, CREVIS cannot assume responsibility or liability for actual use based on the examples and diagrams.

Warning!



- ✓ **If you don't follow the directions, it could cause a personal injury, damage to the equipment or explosion**
- Do not assemble the products and wire with power applied to the system. Else it may cause an electric arc, which can result into unexpected and potentially dangerous action by field devices. Arching is explosion risk in hazardous locations. Be sure that the area is non-hazardous or remove system power appropriately before assembling or wiring the modules.
- Do not touch any terminal blocks or IO modules when system is running. Else it may cause the unit to an electric shock or malfunction.
- Keep away from the strange metallic materials not related to the unit and wiring works should be controlled by the electric expert engineer. Else it may cause the unit to a fire, electric shock or malfunction.

Caution!

- ✓ **If you disobey the instructions, there may be possibility of personal injury, damage to equipment or explosion. Please follow below Instructions.**
- Check the rated voltage and terminal array before wiring. Avoid the circumstances over 50°C of temperature. Avoid placing it directly in the sunlight.
- Avoid the place under circumstances over 85% of humidity.
- Do not place Modules near by the inflammable material. Else it may cause a fire.
- Do not permit any vibration approaching it directly.
- Go through module specification carefully, ensure inputs, output connections are made with the specifications. Use standard cables for wiring.
- Use Product under pollution degree 2 environment..

1.1. Safety Instruction

1.1.1. Symbols

<p>DANGER</p> 	<p>Identifies information about practices or circumstances that can cause an explosion in a hazardous environment, which may lead to personal injury or death property damage, or economic loss.</p>
<p>IMPORTANT</p>	<p>Identifies information that is critical for successful application and understanding of the product</p>
<p>ATTENTION</p> 	<p>Identifies information about practices or circumstances that can lead to personal injury, property damage, or economic loss.</p> <p>Attentions help you to identify a hazard, avoid a hazard, and recognize the consequences</p>

1.1.2. Safety Notes

<p>DANGER</p> 	<p>The modules are equipped with electronic components that may be destroyed by electrostatic discharge. When handling the modules, ensure that the environment (persons, workplace and packing) is well grounded. Avoid touching conductive components, e.g. FnBUS Pin.</p>
--	--

1.1.3. Certification

c-UL-us UL Listed Industrial Control Equipment, certified for U.S. and Canada

See UL File E235505

DNV CERTIFICATE No. A-10666

CE Certificate

EN 61000-6-2; Industrial Immunity

EN 61000-6-4; Industrial Emissions

2. DIGITAL OUTPUT MODULE LIST

ST-Number	Description	ID(hex)	Production Status
ST-2114	4 Points TTL Inverting, 5Vdc/20mA, Terminal	81 00 0D	Active
ST-2124	4 Points TTL Non-Inverting, 5Vdc/20mA, Terminal	81 00 0F	Active
ST-221F	16 Points Sink(Negative Logic), 24Vdc/0.5A, 20P Connector	81 01 15	Active
ST-222F	16 Points Source(Positive Logic), 24Vdc/0.5A, 20P Connector	81 01 16	Active
ST-2314	4 Points Sink(Negative Logic), 24Vdc/0.5A, Terminal	81 00 0E	Active
ST-2318	8 Points Sink(Negative Logic), 24Vdc/0.5A, Terminal	81 00 11	Active
ST-2324	4 Points Source(Positive Logic), 24Vdc/0.5A, Terminal	81 00 10	Active
ST-2328	8 Points Source(Positive Logic), 24Vdc/0.5A, Terminal	81 00 12	Active
ST-2414	4 Points Sink(Negative Logic), 24Vdc/0.5A, Terminal, Diagnostics	81 00 08	Active
ST-2424	4 Points Source(Positive Logic), 24Vdc/0.5A, Terminal, Diagnostics	C1 00 00 38	Active
ST-2514	4 Points Sink(Negative Logic), 24Vdc/2A, Terminal, Diagnostics	C1 00 00 35	Active
ST-2524	4 Points Source(Positive Logic), 24Vdc/2A, Terminal, Diagnostics	C1 00 00 36	Active
ST-2614	4 Points Sink(Negative Logic), 24Vdc/2A, Terminal	81 00 3B	Active
ST-2624	4 Points Source(Positive Logic), 24Vdc/2A, Terminal	81 00 3C	Active
ST-2742	2 Points, 230Vac/2A, 24Vdc/2A, Relay	81 00 0B	Active
ST-2744	4 Points, 230Vac/2A, 24Vdc/2A, Relay	81 00 51	Active
ST-2748	8 Points, 230Vac/2A, 24Vdc/2A, Relay	81 00 50	Active
ST-2792	2 Points, 230Vac/2A, 24Vdc/2A, Relay, Manual/Auto	C1 00 01 BE	Active
ST-2852	2 Points, 12~125Vac/0.5A, Triac	81 00 0C	Active
ST-2924	4 Points, 24Vac/2A, 24Vdc/2A, 4 Points/4COM	81 00 C0	NEW
ST-2944	4 Points, 24Vac/2A, 24Vdc/2A, 1 Points/1COM	81 00 C1	NEW
ST-2734	4 Points, 24~220Vac/0.5A, 24~220Vdc/0.5A, 1 Points/1COM	81 00 C2	NEW

3. Specification

3.1. The Interface

3.1.1. ST-2114

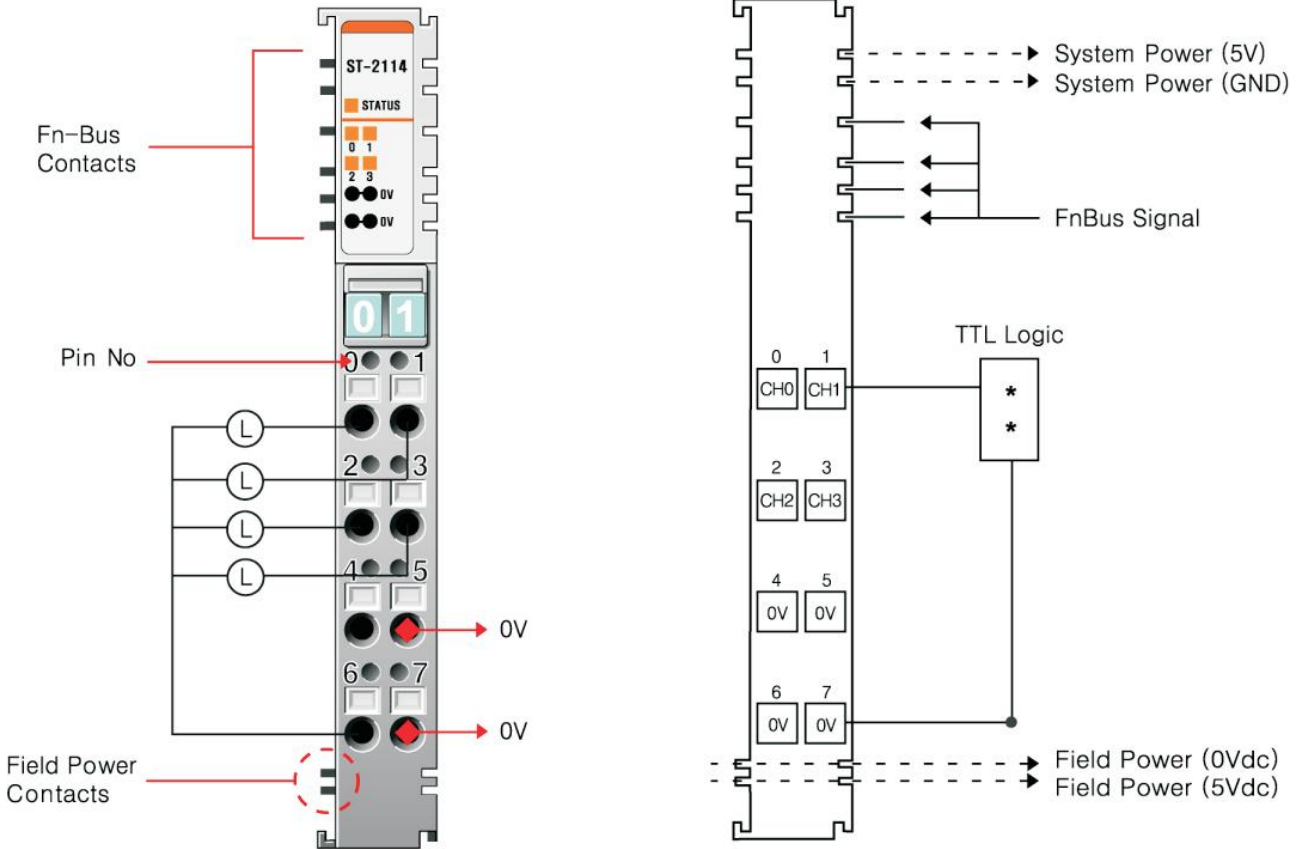

Pin No.	Description	Pin No.	Description
0	Output Channel 0	1	Output Channel 1
2	Output Channel 2	3	Output Channel 3
4	Field Ground (0V)	5	Field Ground (0V)
6	Field Ground (0V)	7	Field Ground (0V)

3.1.2. ST-2124

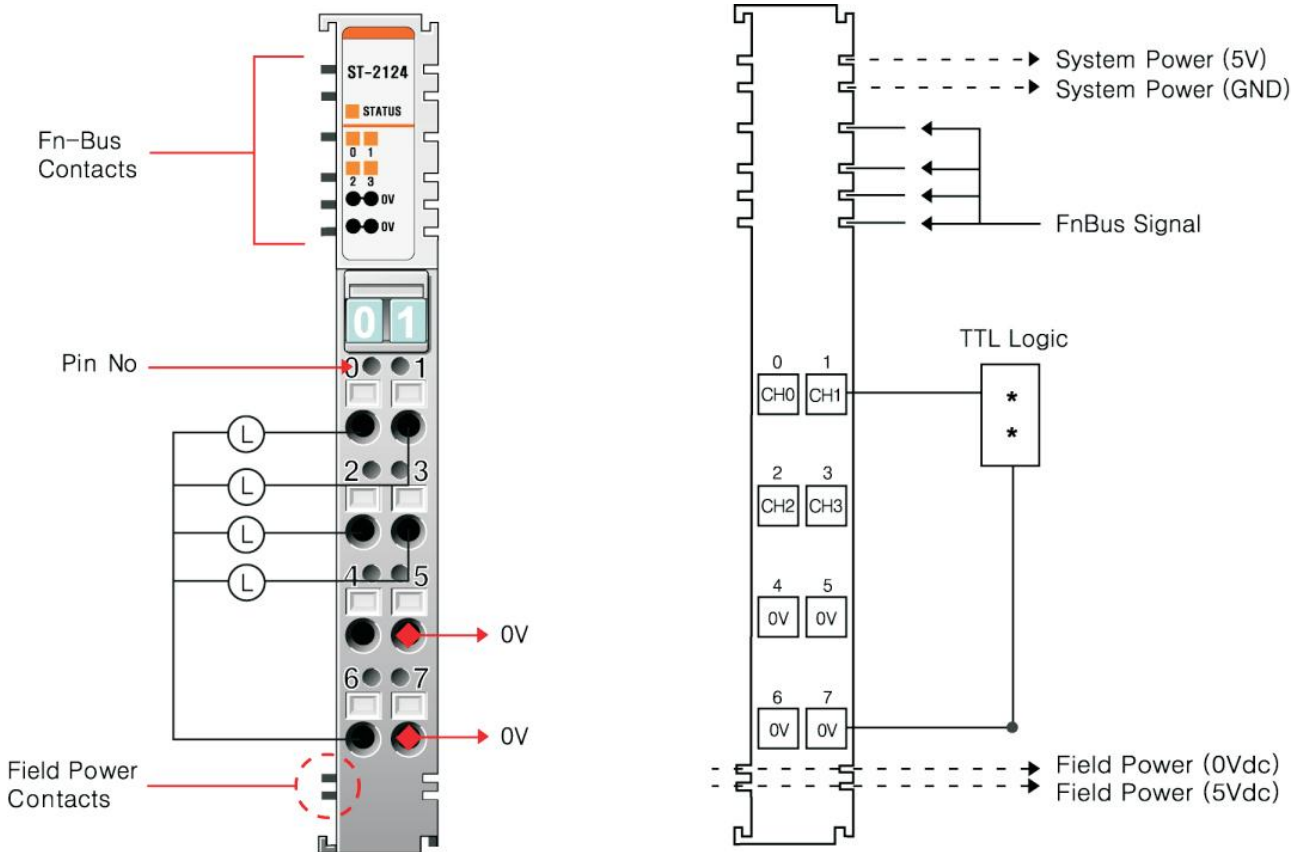

Pin No.	Description	Pin No.	Description
0	Output Channel 0	1	Output Channel 1
2	Output Channel 2	3	Output Channel 3
4	Field Ground (0V)	5	Field Ground (0V)
6	Field Ground (0V)	7	Field Ground (0V)

3.1.3. ST-221F

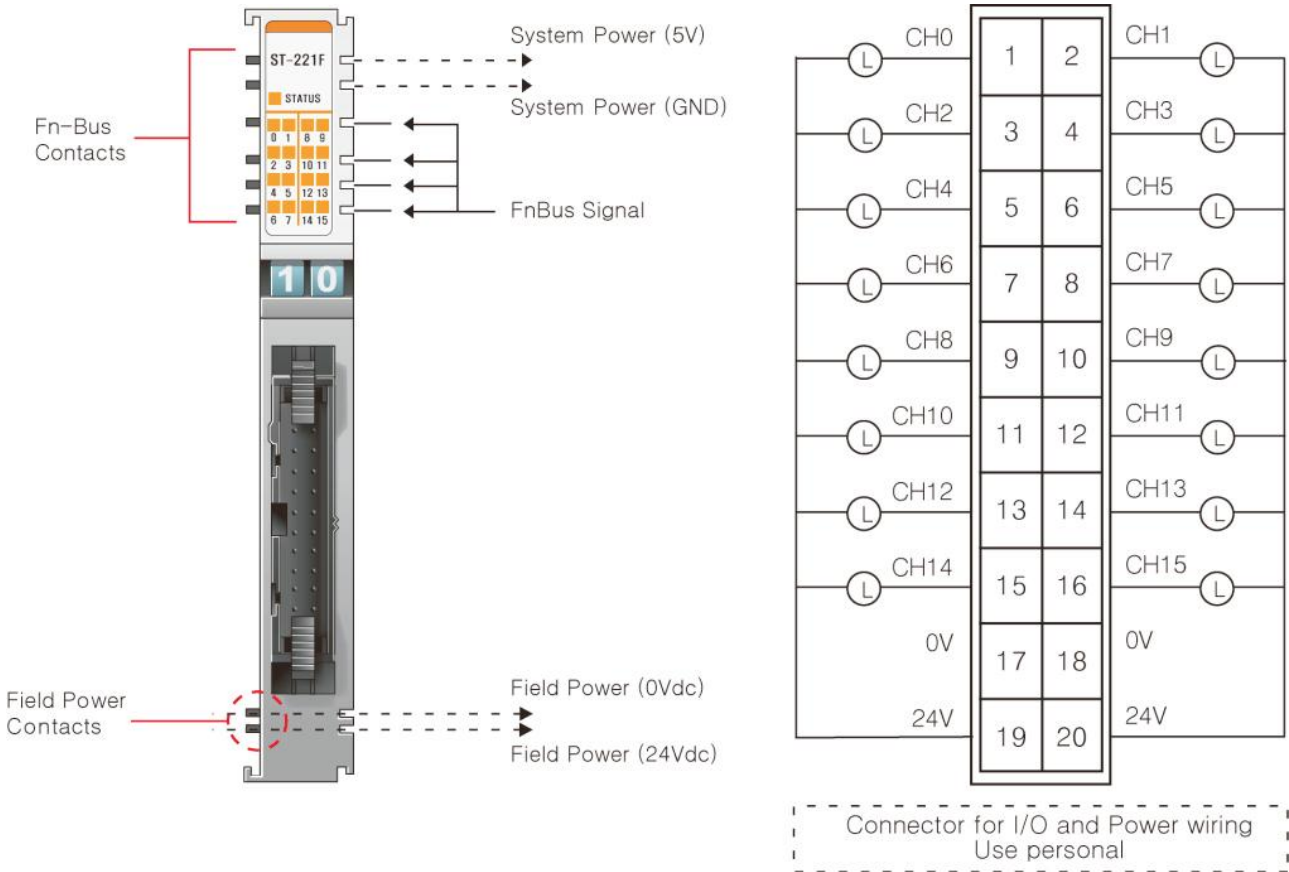

Pin No.	Description	Pin No.	Description
1	Output Channel 0	2	Output Channel 1
3	Output Channel 2	4	Output Channel 3
5	Output Channel 4	6	Output Channel 5
7	Output Channel 6	8	Output Channel 7
9	Output Channel 8	10	Output Channel 9
11	Output Channel 10	12	Output Channel 11
13	Output Channel 12	14	Output Channel 13
15	Output Channel 14	16	Output Channel 15
17	Field Ground(0V)	18	Field Ground(0V)
19	Field Power (+24Vdc)	20	Field Power (+24Vdc)

3.1.4. ST-222F

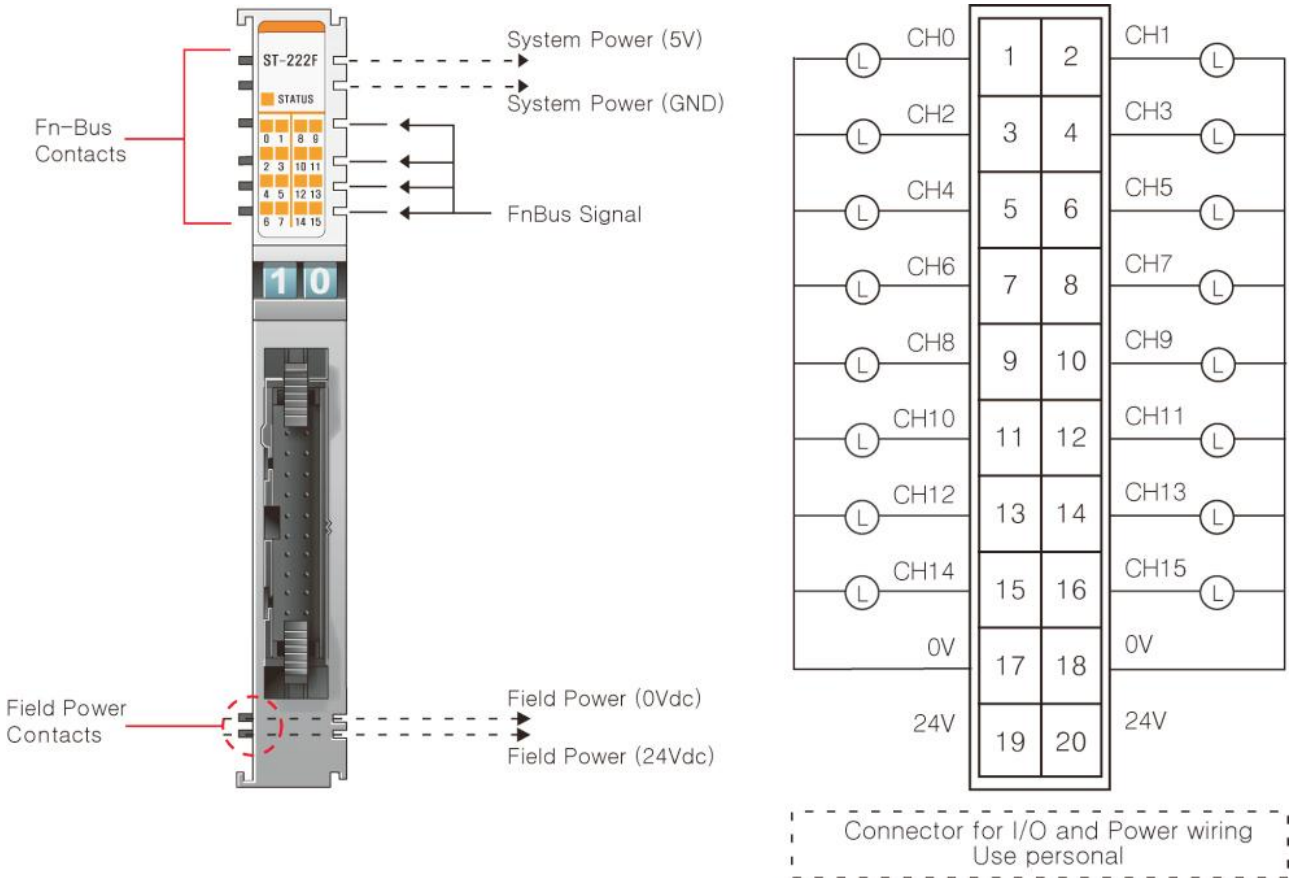

Pin No.	Description	Pin No.	Description
1	Output Channel 0	2	Output Channel 1
3	Output Channel 2	4	Output Channel 3
5	Output Channel 4	6	Output Channel 5
7	Output Channel 6	8	Output Channel 7
9	Output Channel 8	10	Output Channel 9
11	Output Channel 10	12	Output Channel 11
13	Output Channel 12	14	Output Channel 13
15	Output Channel 14	16	Output Channel 15
17	Field Ground(0V)	18	Field Ground(0V)
19	Field Power (+24Vdc)	20	Field Power (+24Vdc)

3.1.5. ST-2314

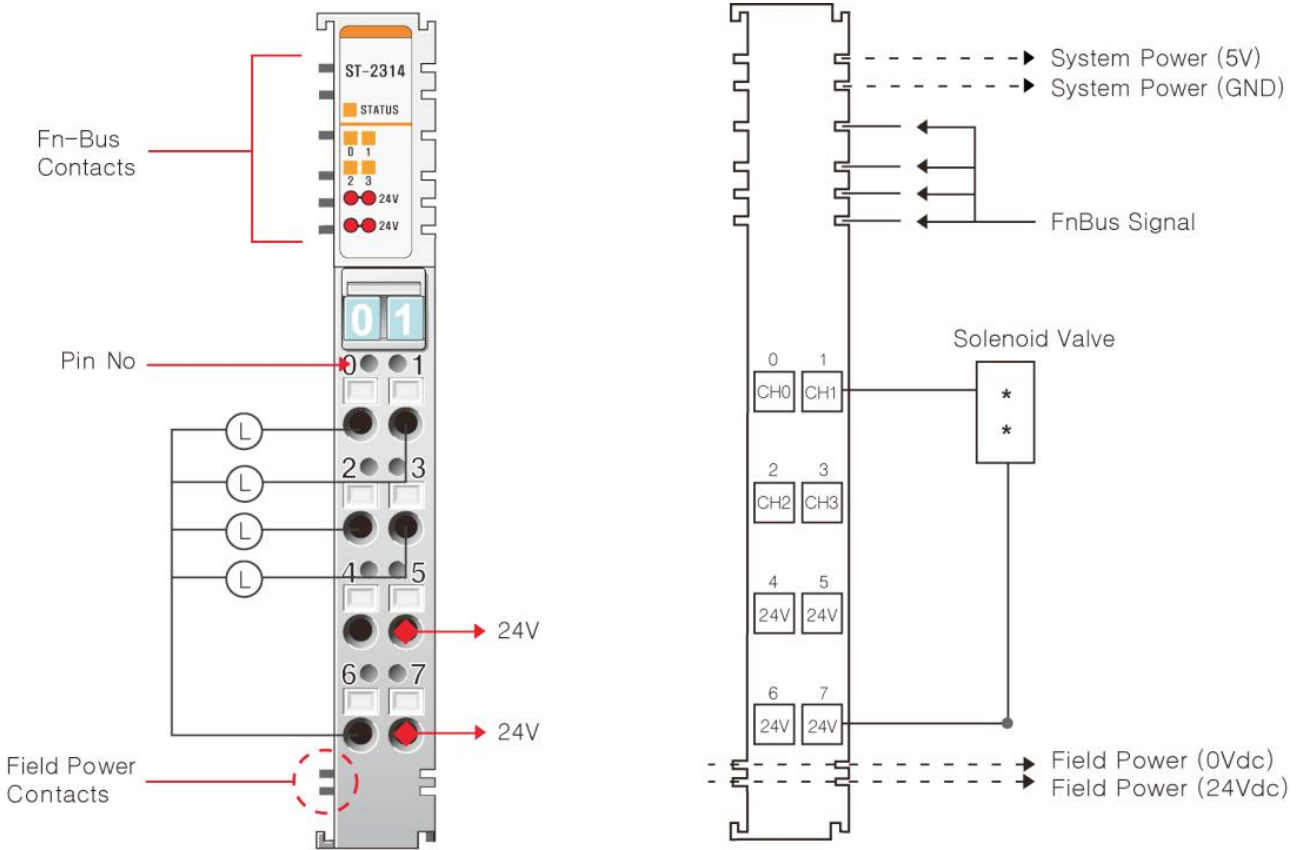

Pin No.	Description	Pin No.	Description
0	Output Channel 0	1	Output Channel 1
2	Output Channel 2	3	Output Channel 3
4	Field Power (+24Vdc)	5	Field Power (+24Vdc)
6	Field Power (+24Vdc)	7	Field Power (+24Vdc)

3.1.6. ST-2318

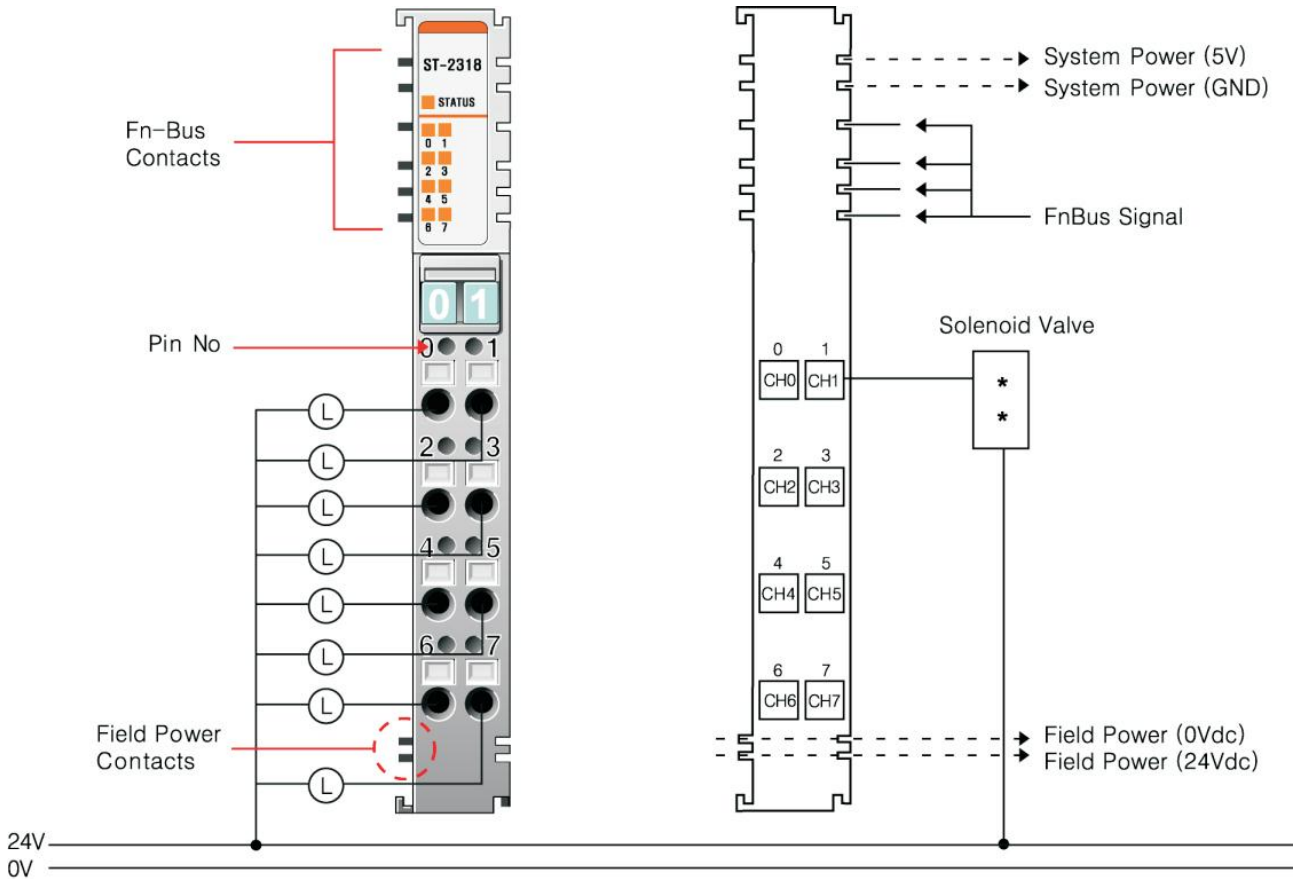

Pin No.	Description	Pin No.	Description
0	Output Channel 0	1	Output Channel 1
2	Output Channel 2	3	Output Channel 3
4	Output Channel 4	5	Output Channel 5
6	Output Channel 6	7	Output Channel 7

3.1.7. ST-2324

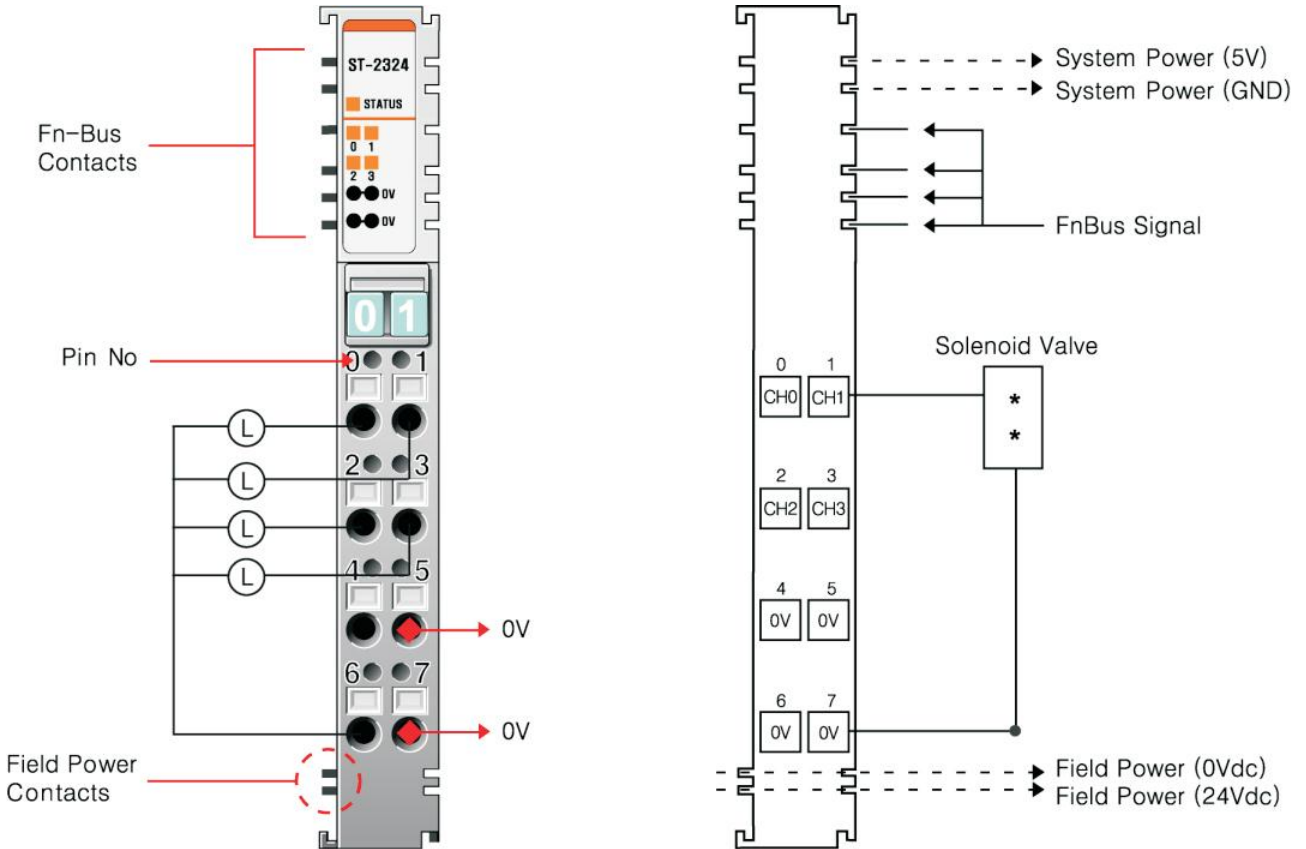

Pin No.	Description	Pin No.	Description
0	Output Channel 0	1	Output Channel 1
2	Output Channel 2	3	Output Channel 3
4	Field Ground (0V)	5	Field Ground (0V)
6	Field Ground (0V)	7	Field Ground (0V)

3.1.8. ST-2328

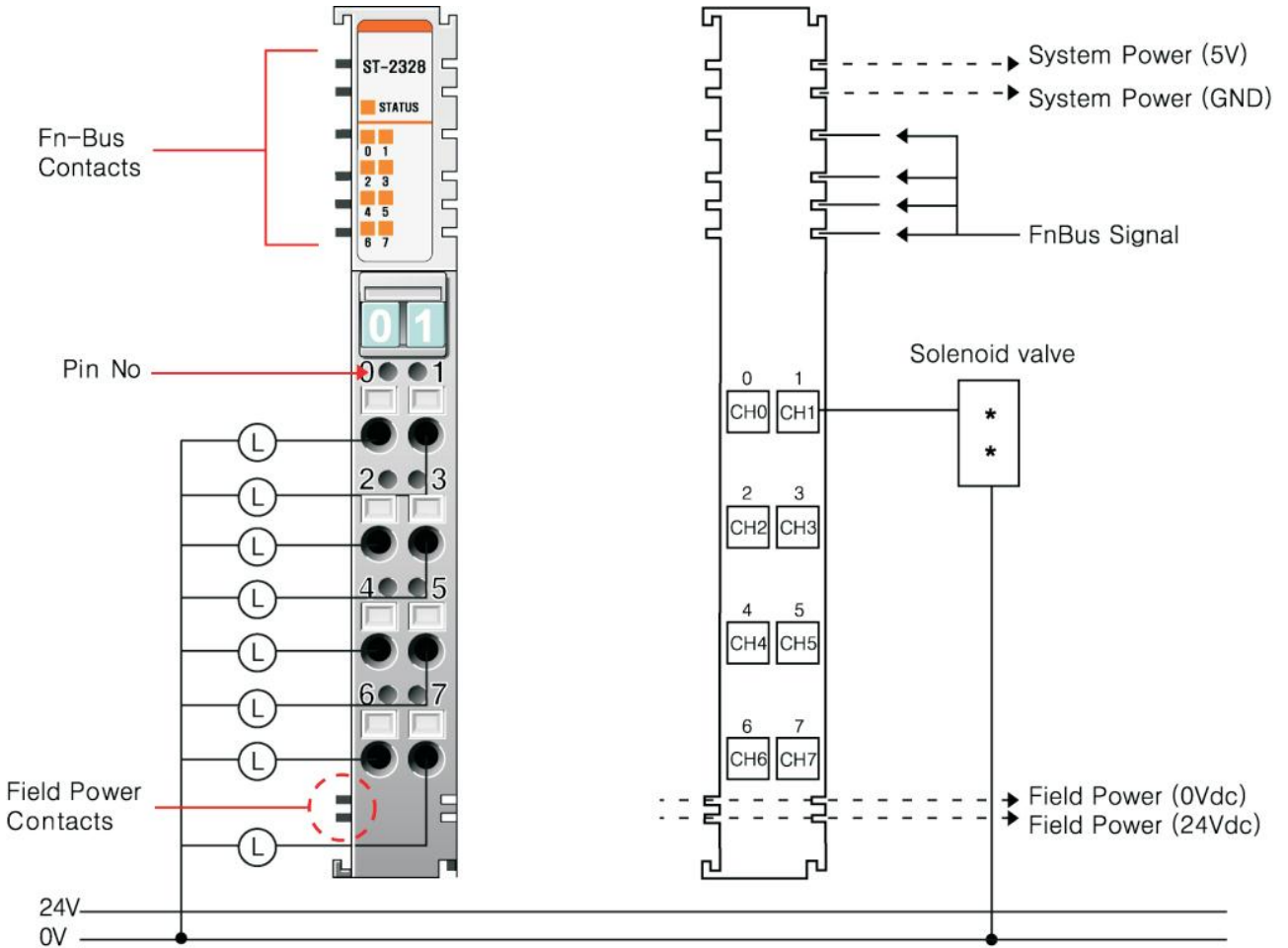

Pin No.	Description	Pin No.	Description
0	Output Channel 0	1	Output Channel 1
2	Output Channel 2	3	Output Channel 3
4	Output Channel 4	5	Output Channel 5
6	Output Channel 6	7	Output Channel 7

3.1.9. ST-2414

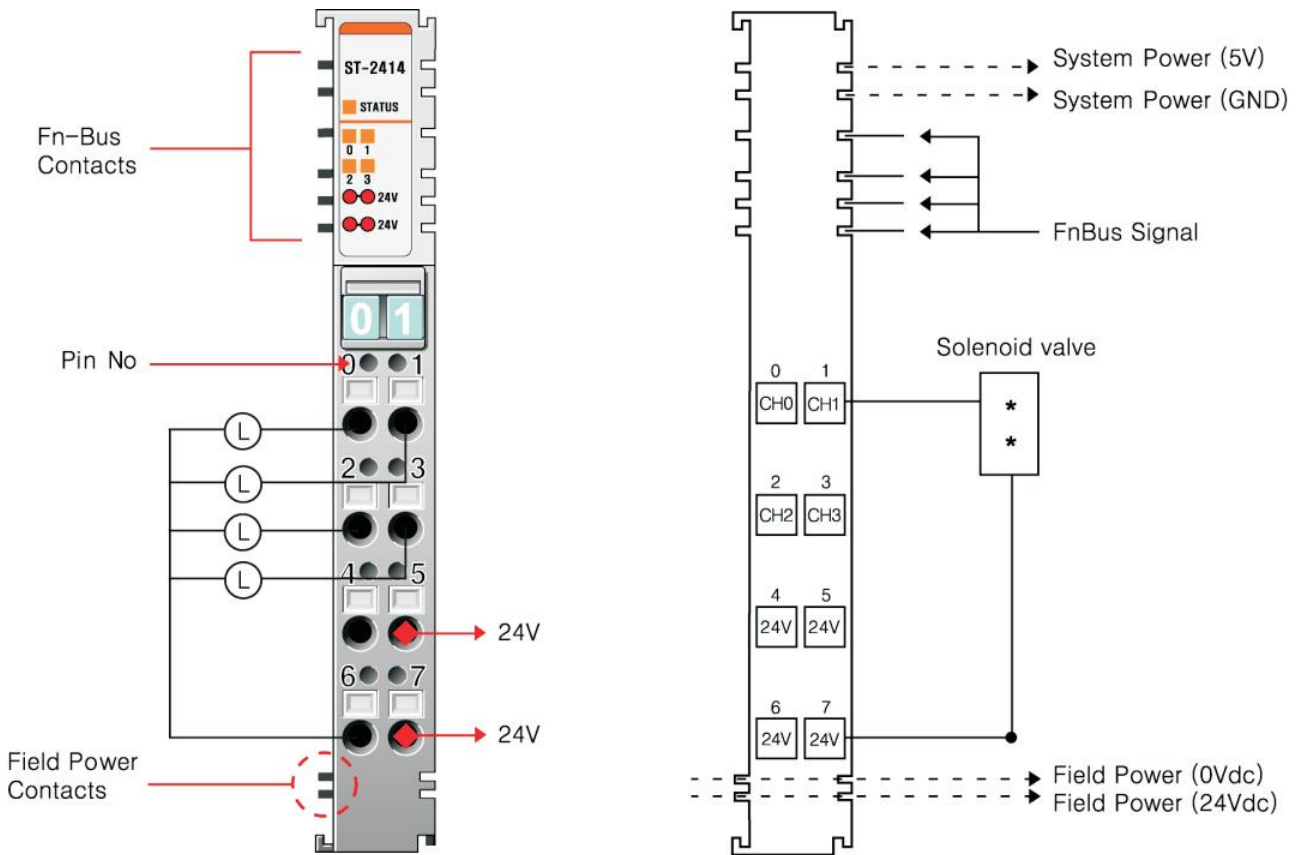

Pin No.	Description	Pin No.	Description
0	Output Channel 0	1	Output Channel 1
2	Output Channel 2	3	Output Channel 3
4	Field Power (+24Vdc)	5	Field Power (+24Vdc)
6	Field Power (+24Vdc)	7	Field Power (+24Vdc)

3.1.10. ST-2424

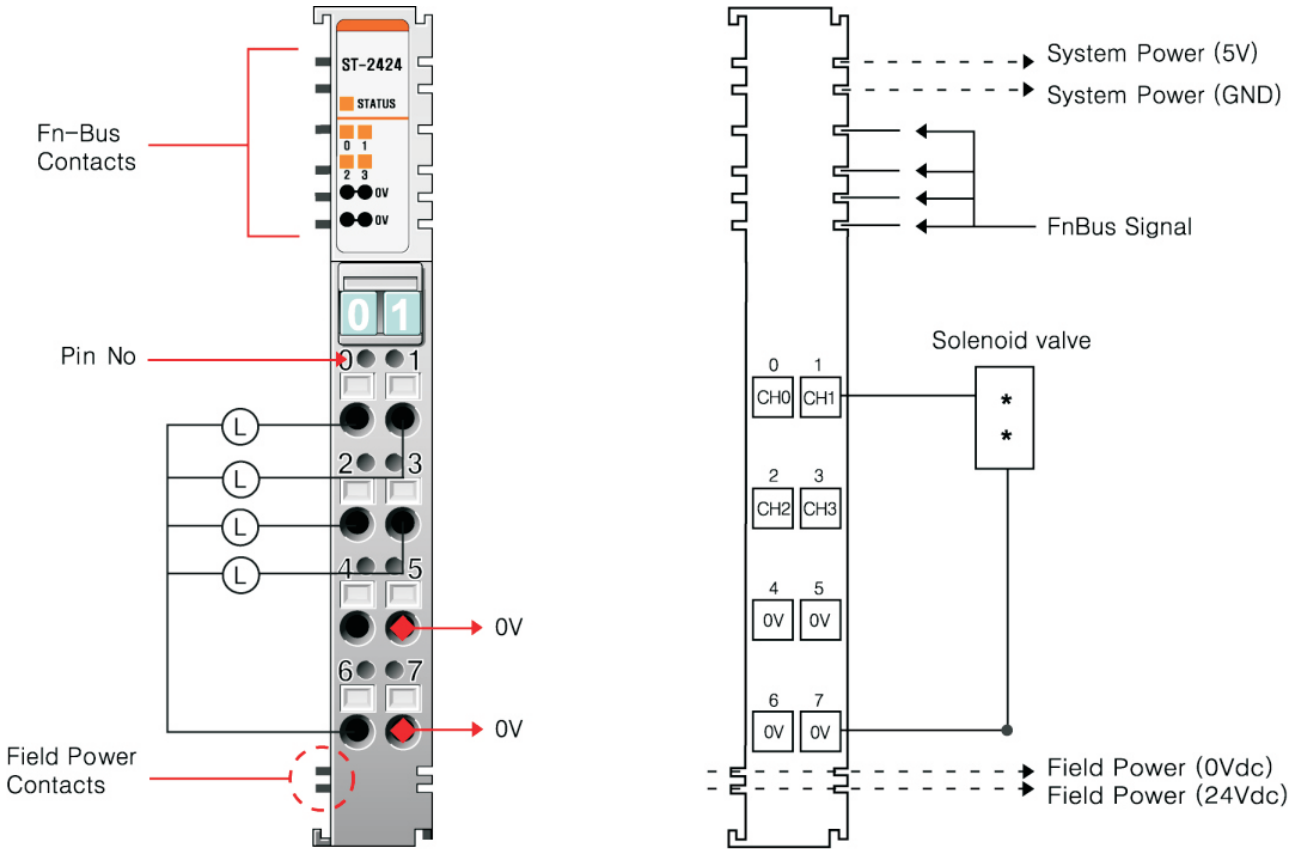

Pin No.	Description	Pin No.	Description
0	Output Channel 0	1	Output Channel 1
2	Output Channel 2	3	Output Channel 3
4	Field Ground (0V)	5	Field Ground (0V)
6	Field Ground (0V)	7	Field Ground (0V)

3.1.11. ST-2514

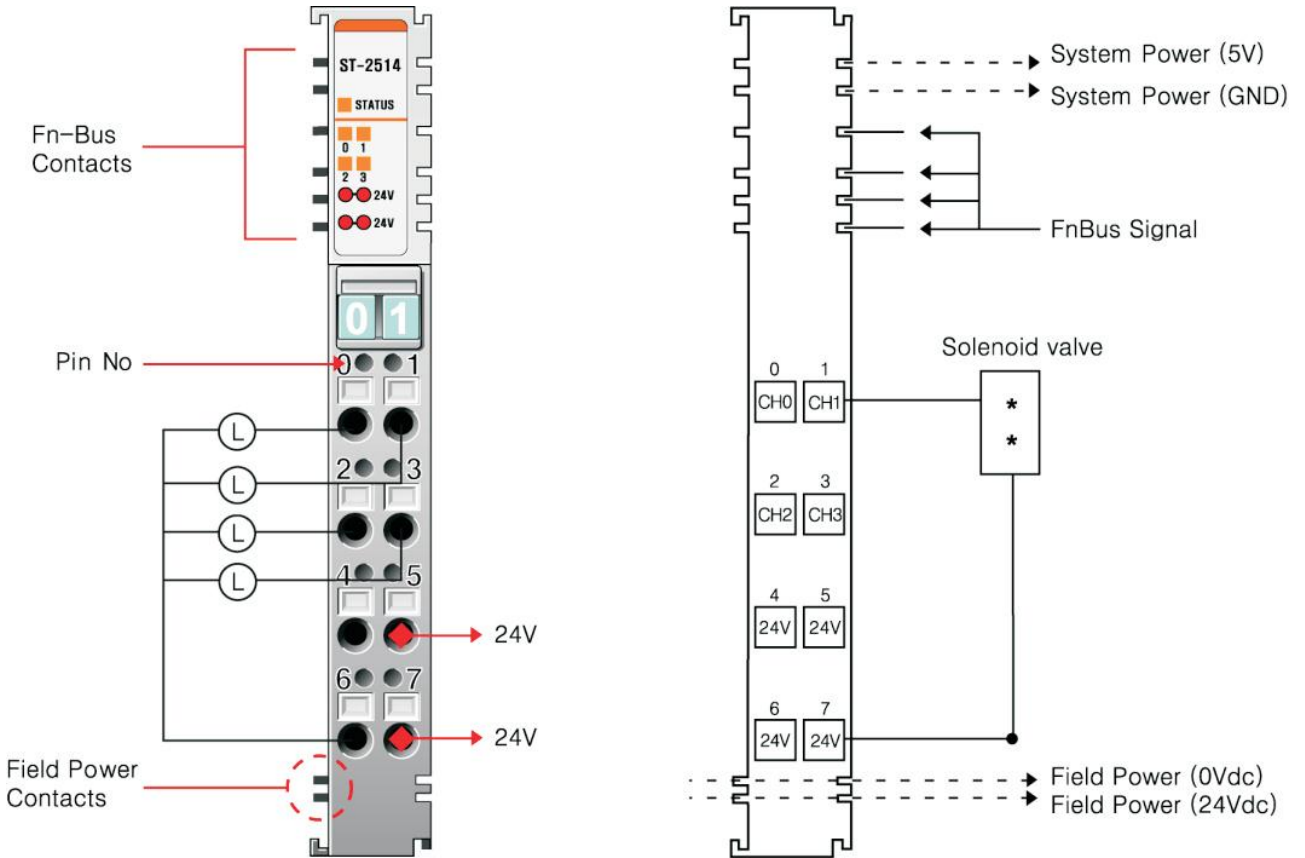

Pin No.	Description	Pin No.	Description
0	Output Channel 0	1	Output Channel 1
2	Output Channel 2	3	Output Channel 3
4	Field Power (+24Vdc)	5	Field Power (+24Vdc)
6	Field Power (+24Vdc)	7	Field Power (+24Vdc)

3.1.12. ST-2524

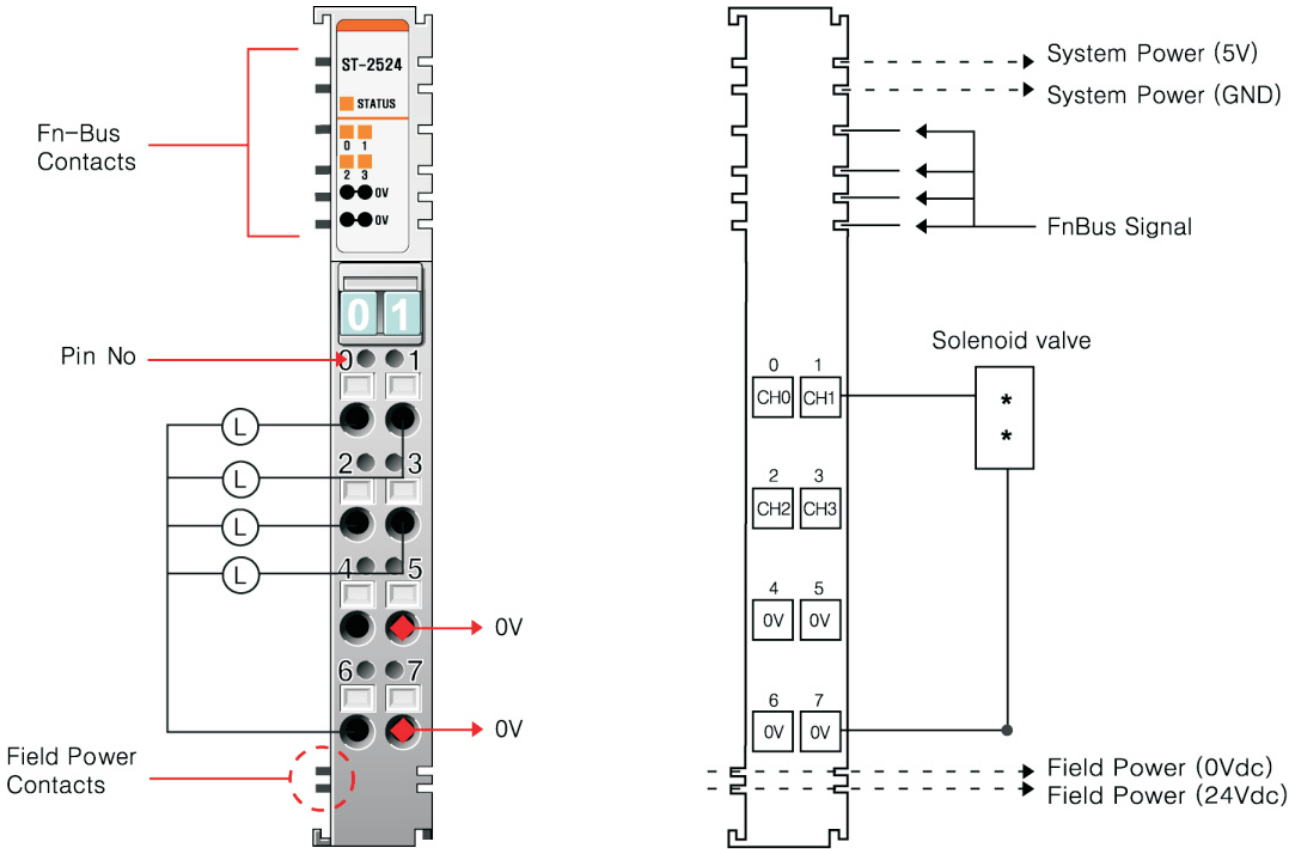

Pin No.	Description	Pin No.	Description
0	Output Channel 0	1	Output Channel 1
2	Output Channel 2	3	Output Channel 3
4	Field Ground (0V)	5	Field Ground (0V)
6	Field Ground (0V)	7	Field Ground (0V)

3.1.13. ST-2614

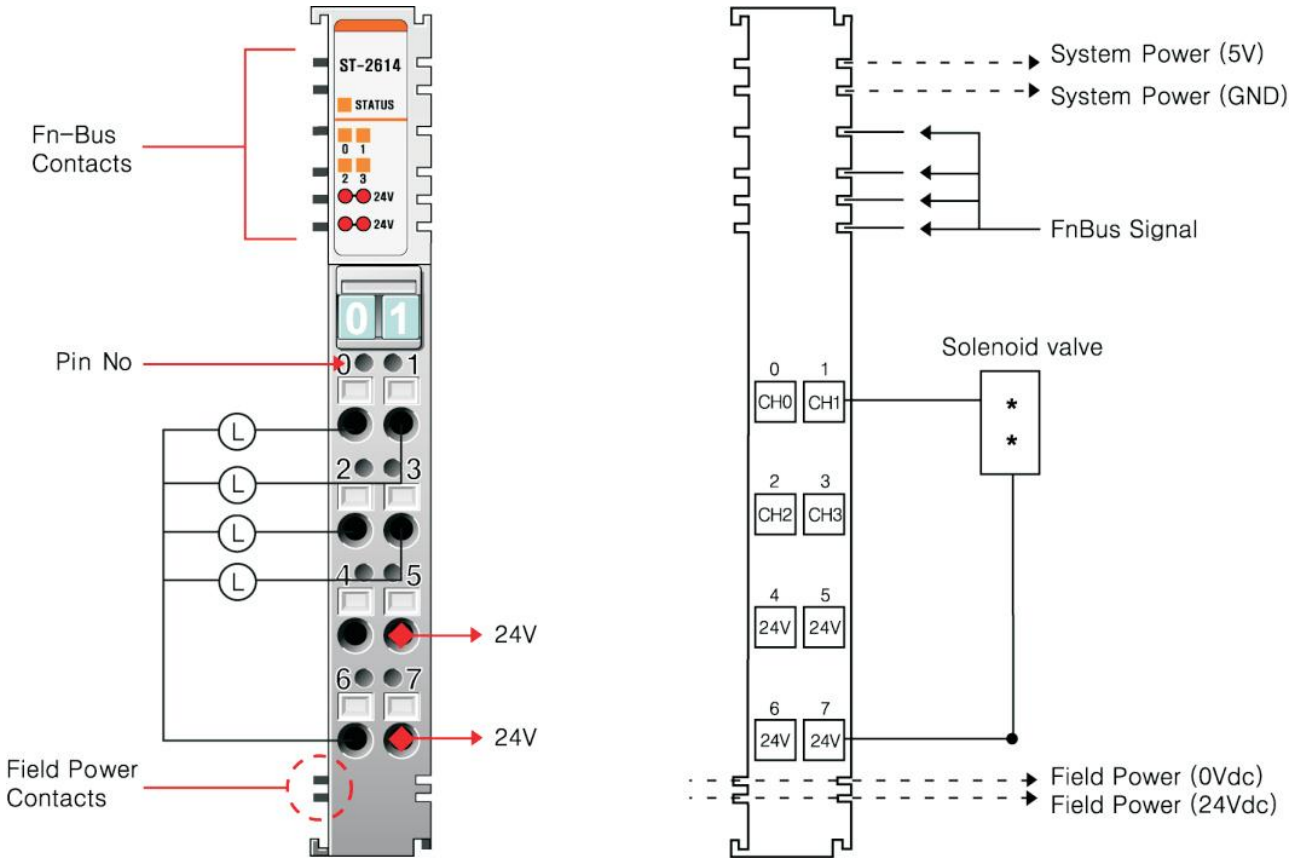

Pin No.	Description	Pin No.	Description
0	Output Channel 0	1	Output Channel 1
2	Output Channel 2	3	Output Channel 3
4	Field Power (+24Vdc)	5	Field Power (+24Vdc)
6	Field Power (+24Vdc)	7	Field Power (+24Vdc)

3.1.14. ST-2624

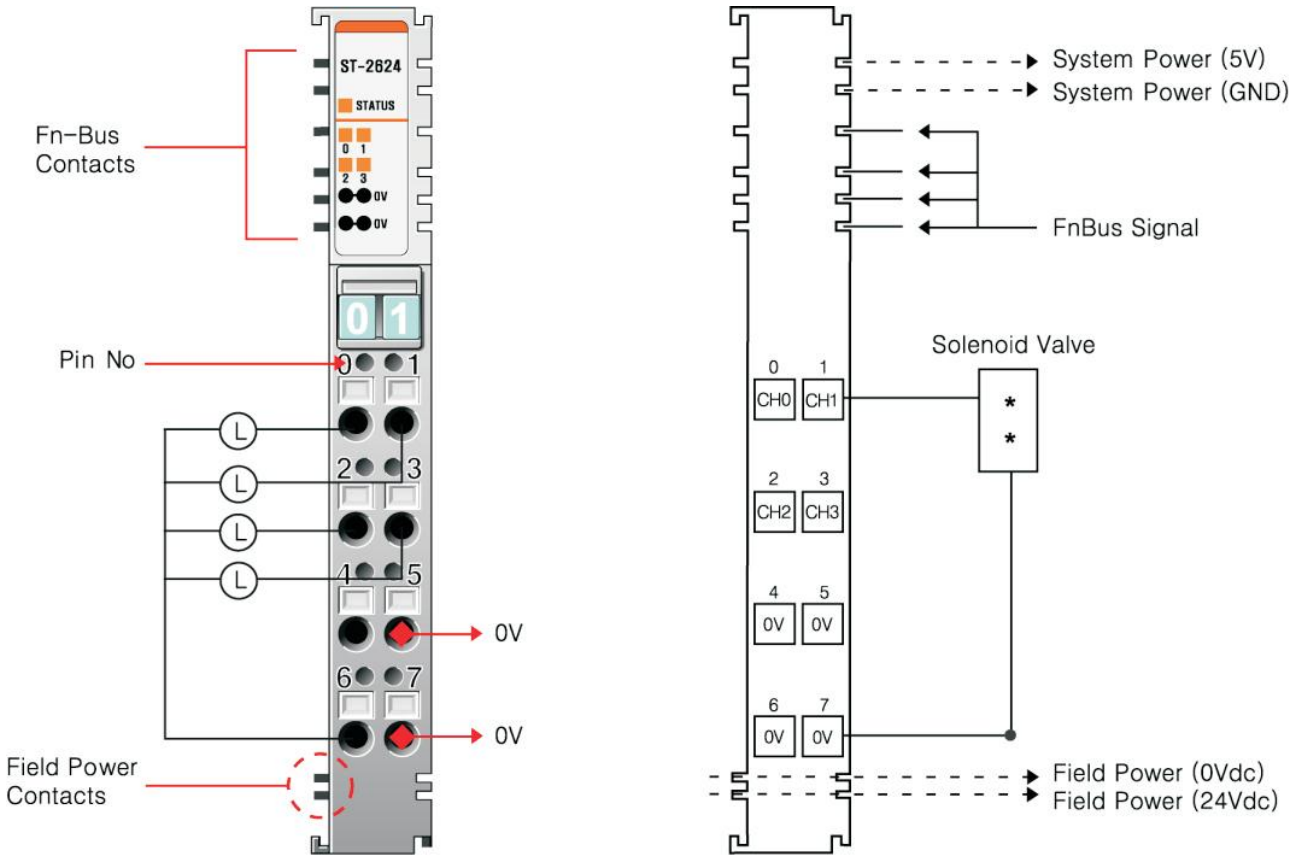

Pin No.	Description	Pin No.	Description
0	Output Channel 0	1	Output Channel 1
2	Output Channel 2	3	Output Channel 3
4	Field Ground (0V)	5	Field Ground (0V)
6	Field Ground (0V)	7	Field Ground (0V)

3.1.15. ST-2742

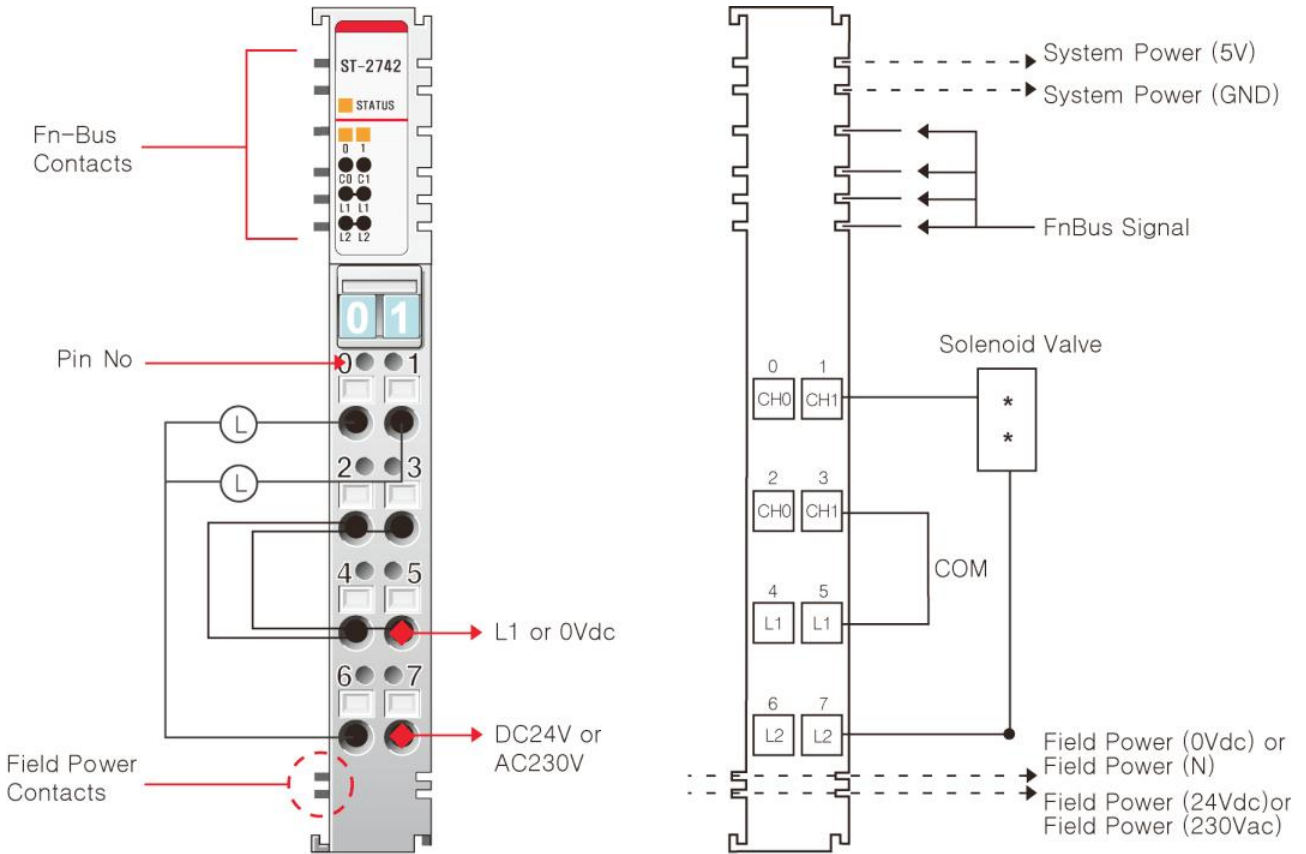

Pin No.	Description	Pin No.	Description
0	Relay Output Channel 0_A	1	Relay Output Channel 1_A
2	Relay Output Channel 0_B	3	Relay Output Channel 1_B
4	L1 / N / Field Ground (0V)	5	L1 / N / Field Ground (0V)
6	L2 Output Field Power (24Vdc/230Vac)	7	L2 Output Field Power (24Vdc/230Vac)

3.1.16. ST-2744

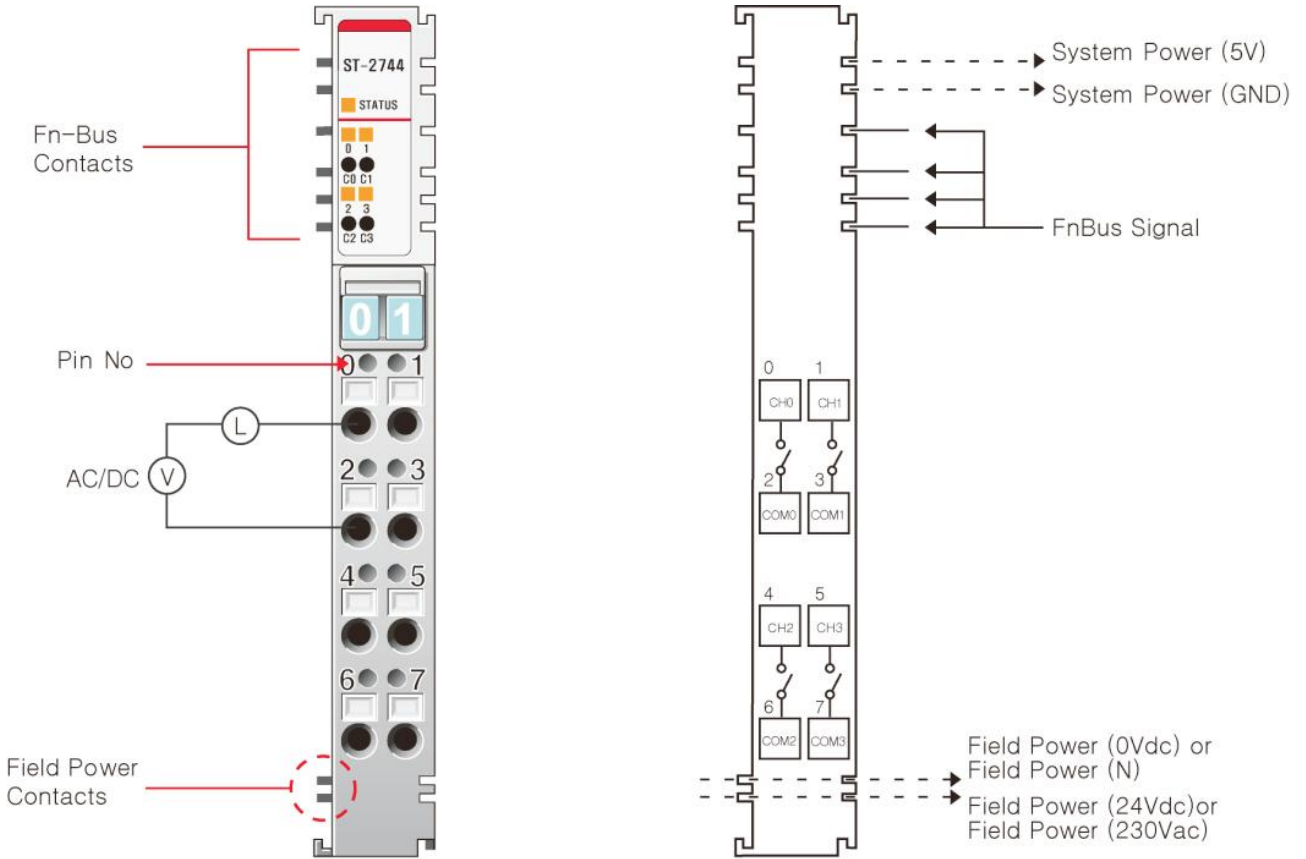

Pin No.	Description	Pin No.	Description
0	Output Channel 0_A	1	Output Channel 1_A
2	COM 0	3	COM 1
4	Output Channel 2_A	5	Output Channel 3_A
6	COM 2	7	COM 3

3.1.17. ST-2748

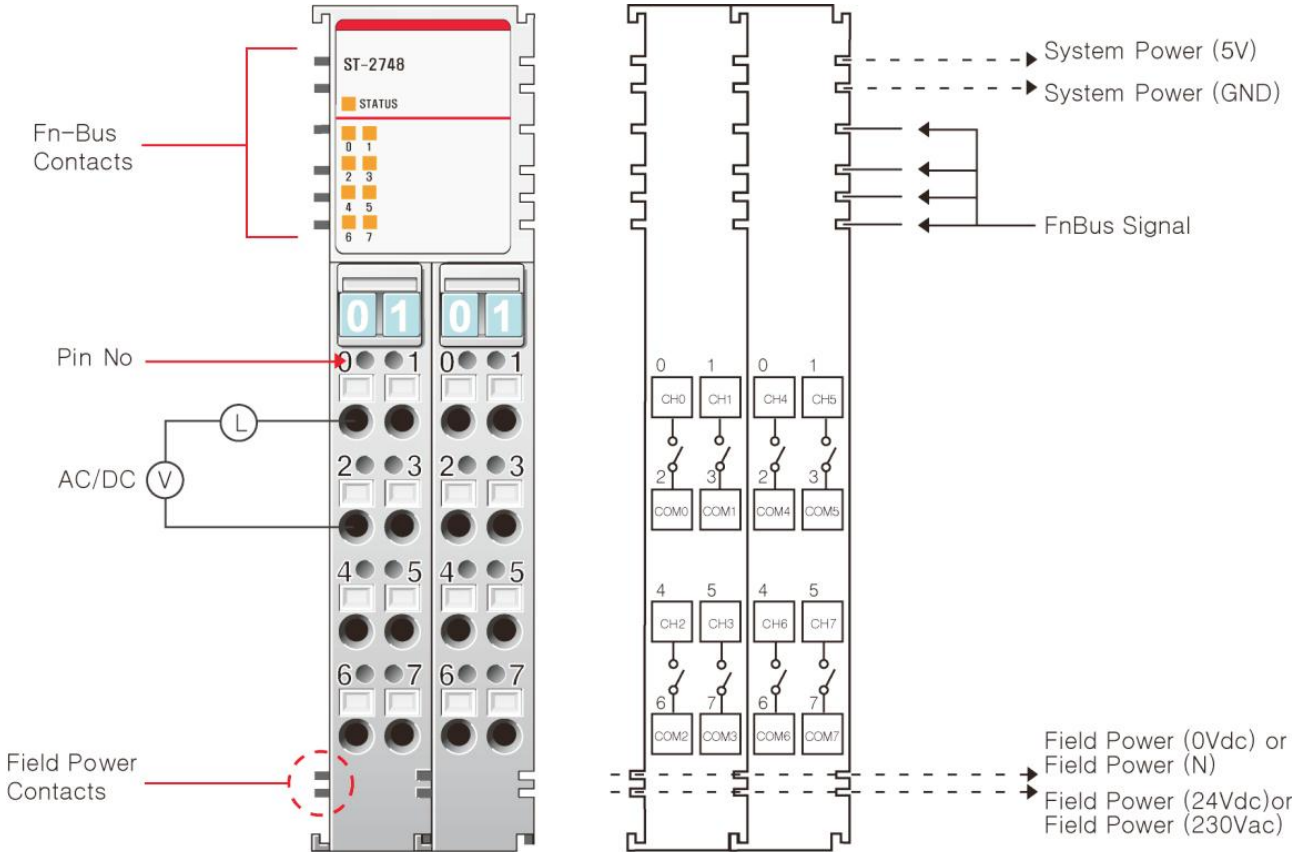

Signals for Left Terminal

Pin No.	Description	Pin No.	Description
0	Output Channel 0_A	1	Output Channel 1_A
2	COM 0	3	COM 1
4	Output Channel 2_A	5	Output Channel 3_A
6	COM 2	7	COM 3

Signal for Right Terminal

Pin No.	Description	Pin No.	Description
0	Output Channel 4_A	1	Output Channel 5_A
2	COM 4	3	COM 5
4	Output Channel 6_A	5	Output Channel 7_A
6	COM 6	7	COM 7

3.1.18. ST-2792

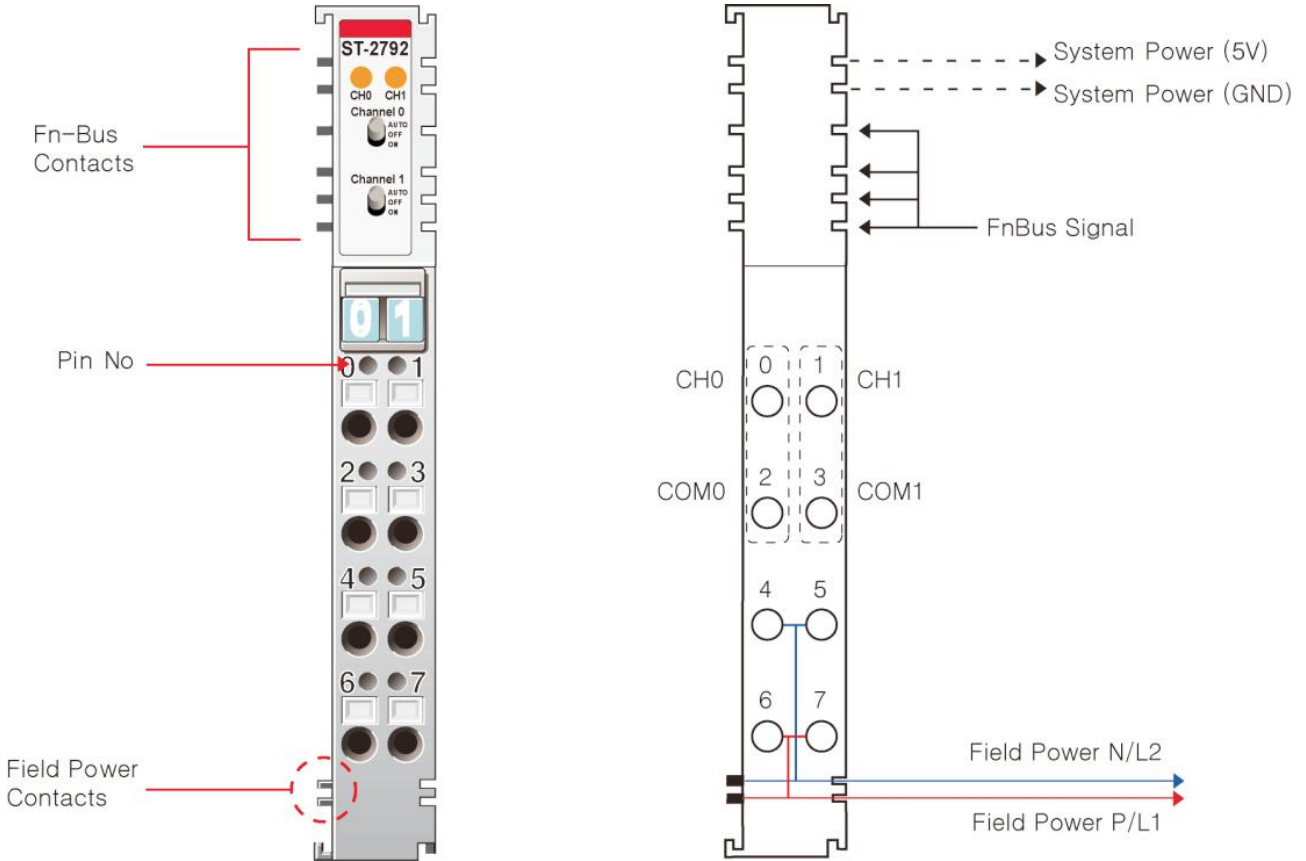

Pin No.	Description	Pin No.	Description
0	Output Channel 0	1	Output Channel 1
2	COM 0	3	COM 1
4	Field Power, N / L1	5	Field Power, N / L1
6	Field Power, P / L2	7	Field Power, P / L2

3.1.19. ST-2852

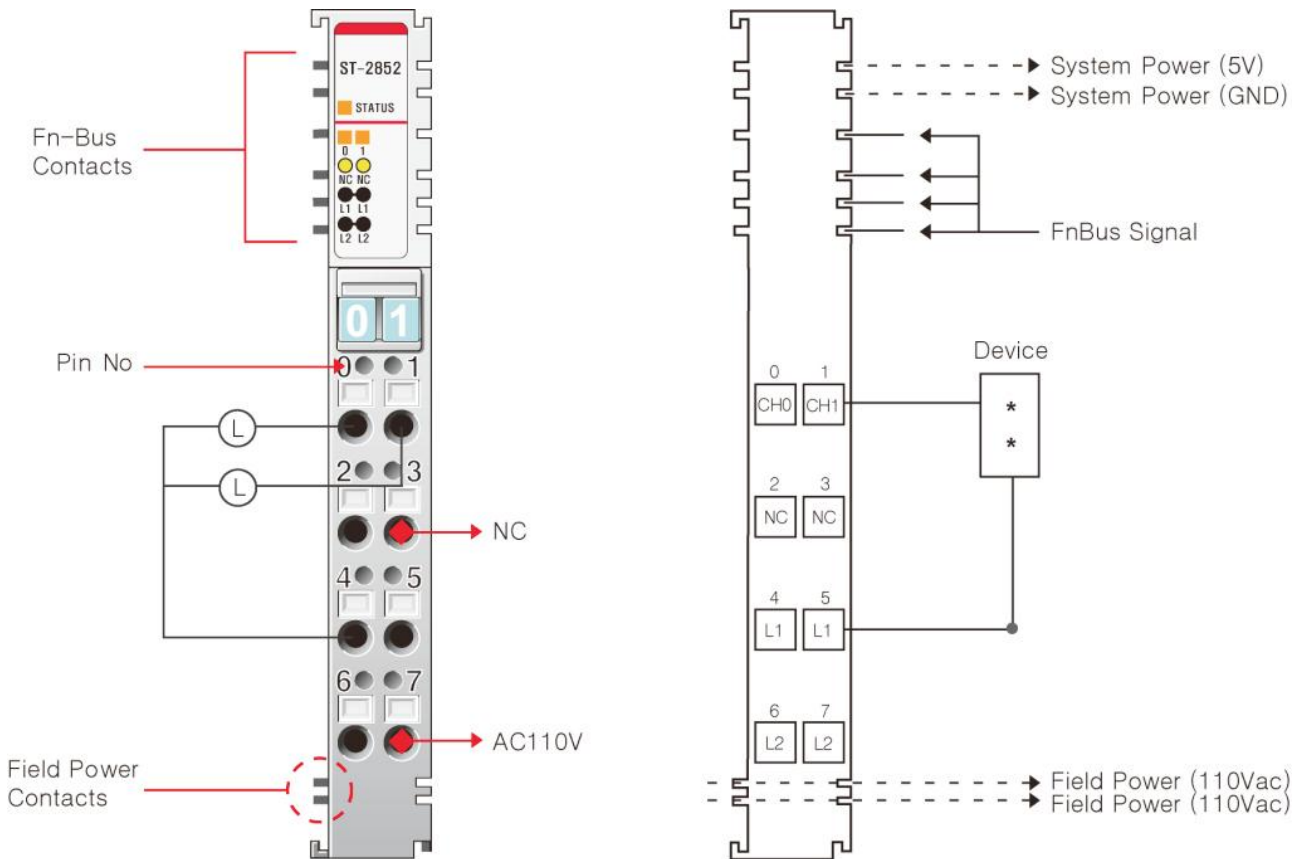

Pin No.	Description	Pin No.	Description
0	Output Channel 0	1	Output Channel 1
2	NC	3	NC
4	L1 Output Field Power (110Vac)	5	L1 Output Field Power (110Vac)
6	L2 Output Field Power (110Vac)	7	L2 Output Field Power (110Vac)

3.1.20. ST-2924

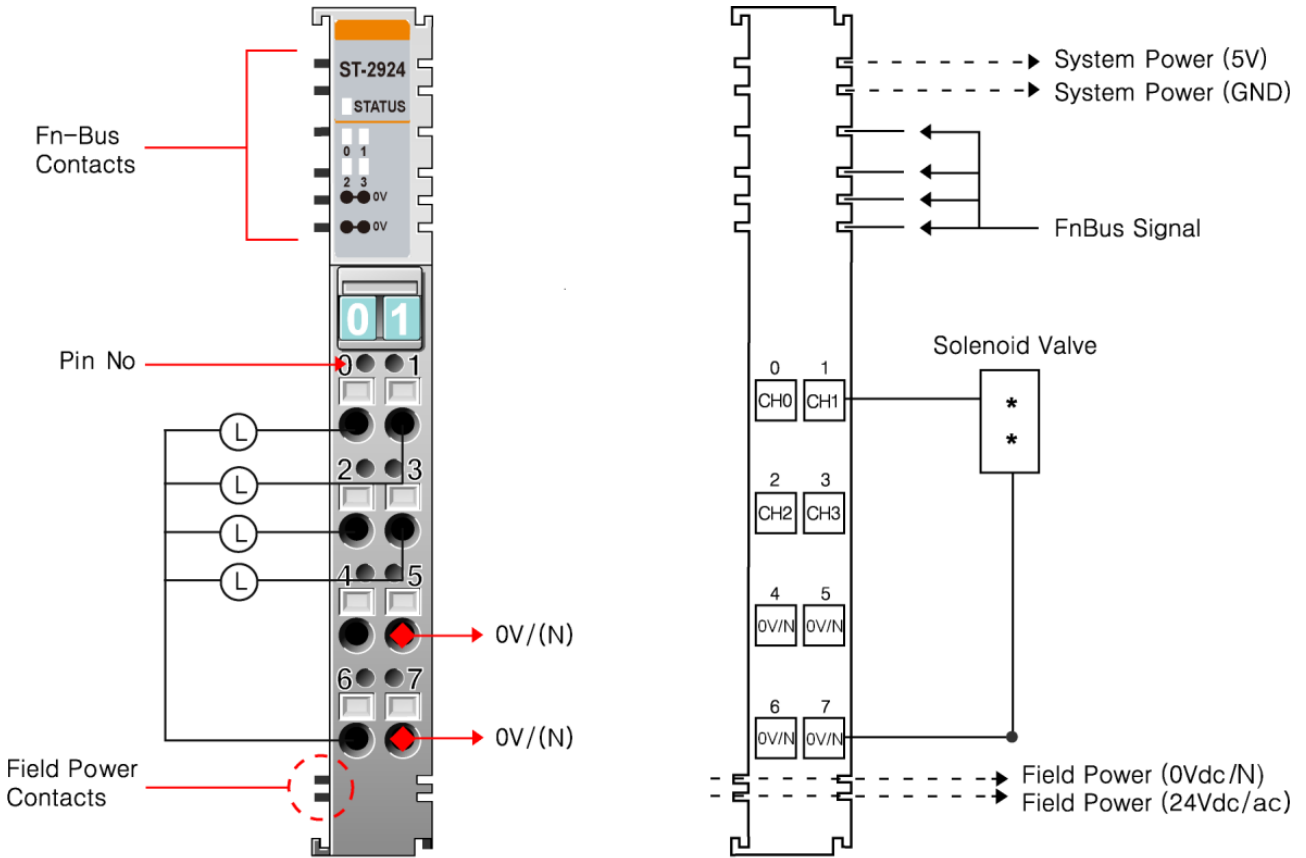

Pin No.	Description	Pin No.	Description
0	Output Channel 0	1	Output Channel 1
2	Output Channel 2	3	Output Channel 3
4	Field Ground 0V / N	5	Field Ground 0V / N
6	Field Ground 0V / N	7	Field Ground 0V / N

3.1.21. ST-2944

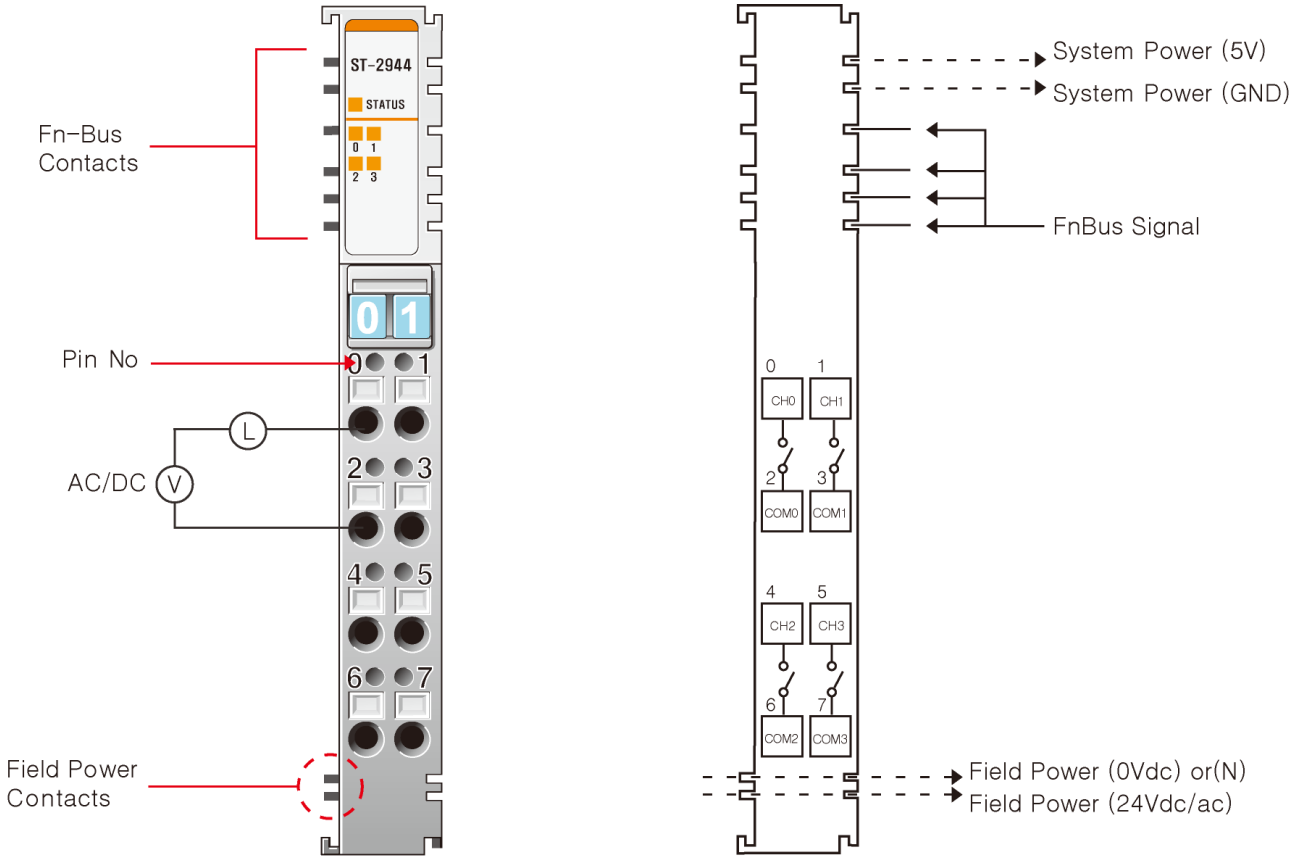

Pin No.	Description	Pin No.	Description
0	Output Channel 0	1	Output Channel 1
2	COM 0	3	COM 1
4	Output Channel 2	5	Output Channel 3
6	COM 2	7	COM 3

3.1.22. ST-2734

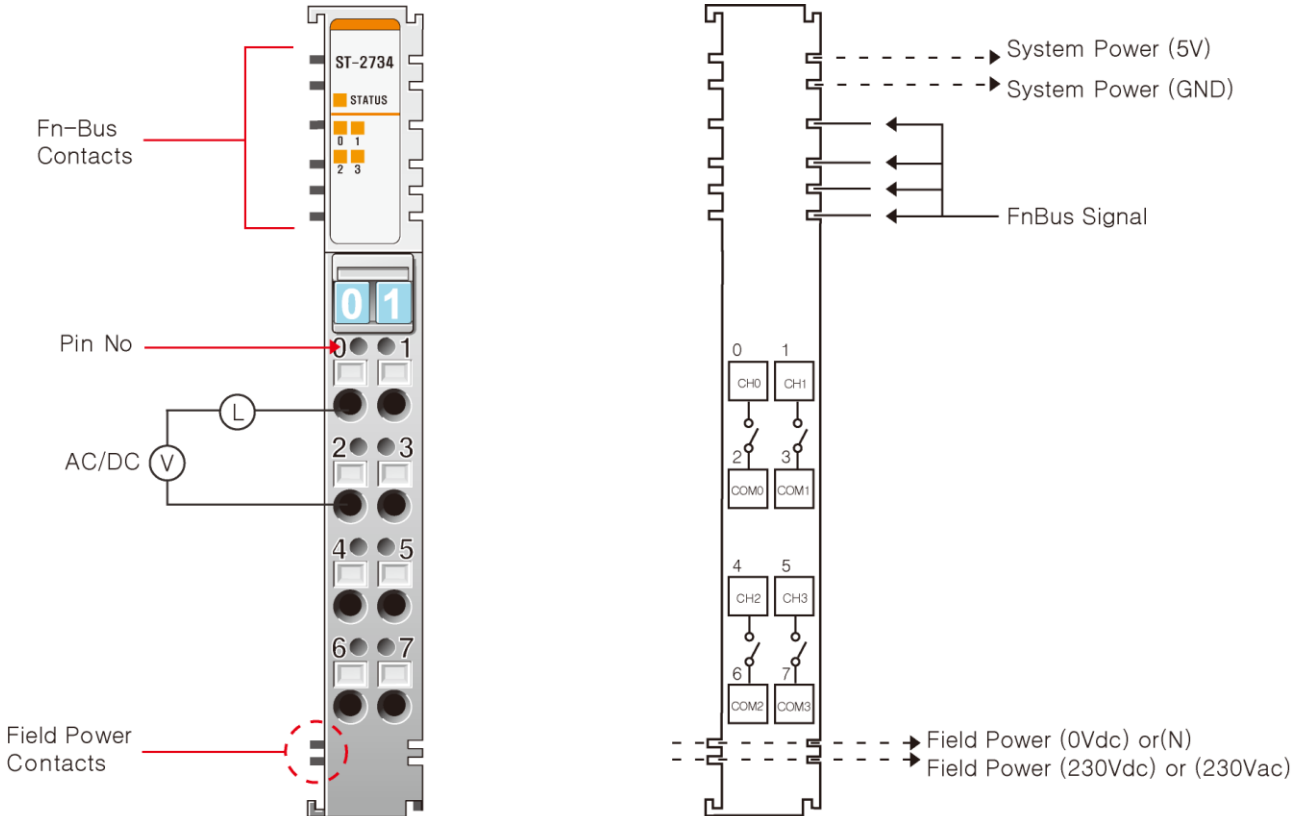

Pin No.	Description	Pin No.	Description
0	Output Channel 0	1	Output Channel 1
2	COM 0	3	COM 1
4	Output Channel 2	5	Output Channel 3
6	COM 2	7	COM 3

3.2. Environment Specification

Environmental Specifications	
Operating Temperature	-20 to 50 °C
Non-Operating Temperature	0 to 50 °C
Relative Humidity	-40 °C to 85 °C
Operating Altitude	5%~90% non-condensing
Mounting	2000m DIN rail
General Specifications	
Shock Operating	10g
Shock Non-Operating	30g
Vibration/Shock resistance	Displacement : 0.012Inch p-p from 10~57Hz Acceleration : 2G's from 57~500Hz Sweep Rate : 1 octave Per Minute Axes to test : x, y, z Frequency Sweeps Per Axis : 10
EMC resistance burst/ESD	Confirms to EN-61000-6-2
EMI	Confirms to EN-61000-6-4
Installation Pos. /Protect. Class	Variable / IP20
Product Certification	UL / cUL, CE
Network Conformance	NA-9111 : ODVA Conformance Test Completion NA-9122 : PTO Conformance Test Completion NA-9131 : CLPA Conformance Test Completion
Isolation	DC Module (Included Analog Module) : Terminal Block to F.G 500Vac/1min AC Module : Terminal Block to F.G 1500Vac/1min Relay Module : Terminal Block to F.G 2500Vac/1min

3.3. Specification

3.3.1. ST-2114

Items	Specification
Output Specification	
Outputs Per Module	4 Point TTL Inverting
Indicators	4 Green Output States, 1 Green/Red FnBUS State
Output Voltage Range	5Vdc nominal Min. 4.5Vdc ~ Max. 5.5Vdc
Operating Frequency	DC to 50Khz
High-Level Output Voltage	Min. 4.8Vdc @ 5Vdc, 5mA
Low-Level Output Voltage	Min. 0.3Vdc @ 0Vdc, 5mA
Output Signal Delay	OFF to ON: Max. 0.3ms ON to OFF: Max. 0.3ms
Output Current Rating	Max. 20mA / Channel Max. 80mA all Common
Protection	Output Short-Circuit protection Field Power Over Voltage Protection (about 6.7Vdc) Field Power Reverse Voltage Protection
Surge Current	40mA For 10ms, Repeatable Every 1 Sec.
Fuse	Non
Common Type	4 Points / 4COM (Single Common)
General Specification	
Power Dissipation	Max. 50mA @ 5.0Vdc
Isolation	I/O to Logic : Photocoupler isolation
Field Power	Supply Voltage : 5Vdc nominal Voltage Range : 4.5~5.5Vdc
Wiring	I/O Cable Max. 2.0mm ² (AWG 14)
Weight	70g
Module Size	12mm × 99mm × 70mm
Environment Condition	Refer to " Environment Specification"(page : 31)

3.3.2. ST-2124

Items	Specification
Output Specification	
Outputs Per Module	4 Point TTL Non-Inverting
Indicators	4 Green Output States, 1 Green/Red FnBUS State
Output Voltage Range	5Vdc nominal Min. 4.5Vdc ~ Max. 5.5Vdc
Operating Frequency	DC to 50Khz
High-Level Output Voltage	Min. 4.8Vdc @ 5Vdc, 5mA
Low-Level Output Voltage	Max. 0.3Vdc @ 0Vdc, 5mA
Output Signal Delay	OFF to ON: Max. 0.3ms ON to OFF: Max. 0.3ms
Output Current Rating	Max. 20mA Per Channel Max. 80mA All Common
Protection	Output Short-Circuit Protection Field Power Over Voltage Protection (about 6Vdc) Field Power Reverse Voltage Protection
Surge Current	40mA For 10ms, Repeatable Every 1 sec
Fuse	Non
Common Type	4 Points / 4COM (Single Common)
General Specification	
Power Dissipation	Max. 50mA @ 5.0Vdc
Isolation	I/O to Logic : Photocoupler isolation
Field Power	Supply Voltage : 5Vdc nominal Voltage Range : 4.5~5.5Vdc Power Dissipation: Max. 70mA@5Vdc
Wiring	I/O Cable Max. 2.0 mm ² (AWG 14)
Weight	70g
Module Size	12mm × 99mm × 70mm
Environment Condition	Refer to " Environment Specification"(page : 31)

3.3.3. ST-221F

Items	Specification
Output Specification	
Outputs Per Module	16 Point Sink Type (Negative Logic)
Indicators	16 Green Output States, 1 Green/Red FnBUS State
Output Voltage Range	24Vdc nominal Min. 11Vdc ~ Max. 28.8Vdc
ON-state Voltage Drop	Max. 0.3Vdc@25°C
ON-State Min. Current	1mA Per Channel
OFF-State Leakage Current	Max. 50uA
Output Signal Delay	OFF to ON: Max. 0.3ms ON to OFF: Max. 0.3ms
Output Current Rating	Max. 0.5A Per Channel Max. 4.0A All Common
Output Protection (VNS3NV04D-E)	Over Temperature Shutdown : Min. 150°C Over Current Limit: Min. 3.5A/Max. 7A Per Channel Short Circuit Protection ESD Protection : 16.5Kv
Common Type	16 Points / 2COM (Single Common)
General Specification	
Power Dissipation	Max. 80mA @ 5.0Vdc
Isolation	I/O to Logic : Photocoupler isolation
Field Power	Supply Voltage : 24Vdc nominal Voltage Range : 11~28.8Vdc Power Dissipation : 3mA@28.8 Vdc / Channel
Wiring	Connector Type
Weight	70g
Module Size	12mm × 99mm × 70mm
Environment Condition	Refer to " Environment Specification"(page : 31)

3.3.4. ST-222F

Items	Specification
Output Specification	
Outputs Per Module	16 Point Source Type (Positive Logic)
Indicators	16 Green Output States, 1 Green/Red FnBUS State
Output Voltage Range	24Vdc nominal Min. 11Vdc ~ Max. 28.8Vdc
ON-state Voltage Drop	Max. 0.3Vdc@25°C
ON-State Min. Current	1mA Per Channel
OFF-State Leakage Current	Max. 50uA
Output Signal Delay	OFF to ON: Max. 0.3ms ON to OFF: Max. 0.3ms
Output Current Rating	Max. 0.5A Per Channel Max. 4.0A All Common
Output Protection (VNS3NV04D-E)	Over Temperature Shutdown : Min. 150°C Over Current Limit: Min. 3.5A/Max. 7A Per Channel Short Circuit Protection ESD Protection : 5Kv
Common Type	16 Points / 2COM (Single Common)
General Specification	
Power Dissipation	Max. 80mA @ 5.0Vdc
Isolation	I/O to Logic : Photocoupler isolation
Field Power	Supply Voltage : 24Vdc nominal Voltage Range : 11~28.8Vdc Power Dissipation : 5mA@28.8 Vdc / Channel
Wiring	Connector Type
Weight	70g
Module Size	12mm × 99mm × 70mm
Environment Condition	Refer to " Environment Specification"(page : 31)

3.3.5. ST-2314

Items	Specification
Output Specification	
Outputs Per Module	4 Point Sink Type (Negative Logic)
Indicators	4 Green Output States, 1 Green/Red FnBUS State
Output Voltage Range	24Vdc nominal Min. 11Vdc ~ Max. 28.8Vdc
ON-state Voltage Drop	Max. 0.3Vdc@25°C
ON-State Min. Current	1mA Per Channel
OFF-State Leakage Current	Max. 50uA
Output Signal Delay	OFF to ON: Max. 0.3ms ON to OFF: Max. 0.3ms
Output Current Rating	Max. 0.5A Per Channel Max. 2.0A All Common
Output Protection (VNS3NV04D-E)	Over Temperature Shutdown : Min. 150°C Over Current Limit: Min. 3.5A/Max. 7A Per Channel Short Circuit Protection ESD Protection : 16.5Kv
Common Type	4 Points / 4COM (Single Common)
General Specification	
Power Dissipation	Max. 45mA @ 5.0Vdc
Isolation	I/O to Logic : Photocoupler isolation
Field Power	Supply Voltage : 24Vdc nominal Voltage Range : 11~28.8Vdc Power Dissipation : 5mA@28.8 Vdc / Channel
Wiring	I/O Cable Max. 2.0 mm ² (AWG 14)
Weight	70g
Module Size	12mm × 99mm × 70mm
Environment Condition	Refer to " Environment Specification"(page : 31)

3.3.6. ST-2318

Items	Specification
Output Specification	
Outputs Per Module	8 Point Sink Type (Negative Logic)
Indicators	8 Green Output States, 1 Green/Red FnBUS State
Output Voltage Range	24Vdc nominal Min. 11Vdc ~ Max. 28.8Vdc
ON-state Voltage Drop	Max. 0.3Vdc@25°C
ON-State Min. Current	1mA Per Channel
OFF-State Leakage Current	Max. 50uA
Output Signal Delay	OFF to ON: Max. 0.3ms ON to OFF: Max. 0.3ms
Output Current Rating	Max. 0.5A Per Channel Max. 4.0A All Common
Output Protection (VNS3NV04D-E)	Over Temperature Shutdown : Min. 150°C Over Current Limit: Min. 3.5A/Max. 7A Per Channel Short Circuit Protection ESD Protection : 16.5Kv
Common Type	8 Points / External Common
General Specification	
Power Dissipation	Max. 60mA @ 5.0Vdc
Isolation	I/O to Logic : Photocoupler isolation
Field Power	Supply Voltage : 24Vdc nominal Voltage Range : 11~28.8Vdc Power Dissipation : 5mA@28.8 Vdc / Channel
Wiring	I/O Cable Max. 2.0 mm ² (AWG 14)
Weight	70g
Module Size	12mm × 99mm × 70mm
Environment Condition	Refer to " Environment Specification"(page : 31)

3.3.7. ST-2324

Items	Specification
Output Specification	
Outputs Per Module	4 Point Source Type (Positive Logic)
Indicators	4 Green Output States, 1 Green/Red FnBUS State
Output Voltage Range	24Vdc nominal Min. 11Vdc ~ Max. 28.8Vdc
ON-state Voltage Drop	Max. 0.3Vdc@25°C
ON-State Min. Current	1mA Per Channel
OFF-State Leakage Current	Max. 50uA
Output Signal Delay	OFF to ON: Max. 0.3ms ON to OFF: Max. 0.3ms
Output Current Rating	Max. 0.5A Per Channel Max. 2.0A All Common
Output Protection (VNS3NV04D-E)	Over Temperature Shutdown : Min. 150°C Over Current Limit: Min. 3.5A/Max. 7.5A Per Channel Short Circuit Protection ESD Protection : 5Kv
Common Type	4 Points / 4COM (Single Common)
General Specification	
Power Dissipation	Max. 45mA @ 5.0Vdc
Isolation	I/O to Logic : Photocoupler isolation
Field Power	Supply Voltage : 24Vdc nominal Voltage Range : 11~28.8Vdc Power Dissipation : 5mA@28.8 Vdc / Channel
Wiring	I/O Cable Max. 2.0 mm ² (AWG 14)
Weight	70g
Module Size	12mm × 99mm × 70mm
Environment Condition	Refer to " Environment Specification"(page : 31)

3.3.8. ST-2328

Items	Specification
Output Specification	
Outputs Per Module	8 Point Source Type (Positive Logic)
Indicators	8 Green Output States, 1 Green/Red FnBUS State
Output Voltage Range	24Vdc nominal Min. 11Vdc ~ Max. 28.8Vdc
ON-state Voltage Drop	Max. 0.3Vdc@25°C
ON-State Min. Current	1mA Per Channel
OFF-State Leakage Current	Max. 50uA
Output Signal Delay	OFF to ON: Max. 0.3ms ON to OFF: Max. 0.3ms
Output Current Rating	Max. 0.5A Per Channel Max. 4.0A All Common
Output Protection (VNS3NV04D-E)	Over Temperature Shutdown : Min. 150°C Over Current Limit: Min. 3.5A/Max. 7.5A Per Channel Short Circuit Protection ESD Protection : 5Kv
Common Type	8 Points / External Common
General Specification	
Power Dissipation	Max. 60mA @ 5.0Vdc
Isolation	I/O to Logic : Photocoupler isolation
Field Power	Supply Voltage : 24Vdc nominal Voltage Range : 11~28.8Vdc Power Dissipation : 5mA@28.8 Vdc / Channel
Wiring	I/O Cable Max. 2.0 mm ² (AWG 14)
Weight	70g
Module Size	12mm × 99mm × 70mm
Environment Condition	Refer to " Environment Specification"(page : 31)

3.3.9. ST-2414

Items	Specification
Output Specification	
Outputs Per Module	4 Point Sink Type (Negative Logic)
Indicators	4 Green Output States, 1 Green/Red FnBUS State
Output Voltage Range	24Vdc nominal Min. 11Vdc ~ Max. 28.8Vdc
ON-state Voltage Drop	Max. 0.3Vdc@25°C
ON-State Min. Current	1mA Per Channel
OFF-State Leakage Current	Max. 50uA
Output Signal Delay	OFF to ON: Max. 0.3ms ON to OFF: Max. 0.3ms
Output Current Rating	Max. 0.5A Per Channel Max. 2.0A All Common
Output Protection (VNS3NV04D-E)	Over Temperature Shutdown : Min. 150°C Over Current Limit: Min. 3.5A/Max. 7A Per Channel Short Circuit Protection ESD Protection : 16.5Kv
Common Type	4 Points / 4COM (Single Common)
General Specification	
Power Dissipation	Max. 45mA @ 5.0Vdc
Isolation	I/O to Logic : Photocoupler isolation
Field Power	Supply Voltage : 24Vdc nominal Voltage Range : 11~28.8Vdc Power Dissipation : 5mA@28.8 Vdc / Channel
Wiring	I/O Cable Max. 2.0 mm ² (AWG 14)
Weight	70g
Module Size	12mm × 99mm × 70mm
Environment Condition	Refer to " Environment Specification"(page : 31)

3.3.10. ST-2424

Items	Specification
Output Specification	
Outputs Per Module	4 Point Source Type (Positive Logic)
Indicators	4 Green Output States, 1 Green/Red FnBUS State
Output Voltage Range	24Vdc nominal Min. 11Vdc ~ Max. 28.8Vdc
ON-state Voltage Drop	Max. 0.3Vdc@25°C
ON-State Min. Current	1mA Per Channel
OFF-State Leakage Current	Max. 50uA
Output Signal Delay	OFF to ON: Max. 0.3ms ON to OFF: Max. 0.3ms
Output Current Rating	Max. 0.5A Per Channel Max. 2.0A All Common
Output Protection (VNS3NV04D-E)	Over Temperature Shutdown : Min. 150°C Over Current Limit: Min. 3.5A/Max. 7.5A Per Channel Short Circuit Protection ESD Protection : 5Kv
Common Type	4 Points / 4COM (Single Common)
General Specification	
Power Dissipation	Max. 45mA @ 5.0Vdc
Isolation	I/O to Logic : Photocoupler isolation
Field Power	Supply Voltage : 24Vdc nominal Voltage Range : 11~28.8Vdc Power Dissipation : 5mA@28.8 Vdc / Channel
Wiring	I/O Cable Max. 2.0 mm ² (AWG 14)
Weight	70g
Module Size	12mm × 99mm × 70mm
Environment Condition	Refer to " Environment Specification"(page : 31)

3.3.11. ST-2514

Items	Specification
Output Specification	
Outputs Per Module	4 Point Sink Type (Negative Logic)
Indicators	4 Green Output States, 1 Green/Red FnBUS State
Output Voltage Range	24Vdc nominal Min. 11Vdc ~ Max. 28.8Vdc
ON-state Voltage Drop	Max. 0.5Vdc@25°C
ON-State Min. Current	1mA Per Channel
OFF-State Leakage Current	Max. 150uA
Output Signal Delay	OFF to ON: Max. 0.3ms ON to OFF: Max. 0.3ms
Output Current Rating	Max. 2A Per Channel Max. 8A All Common
Output Protection (VNS3NV04D-E)	Over Temperature Shutdown : Min. 150°C Over Current Limit: Min. 3.5A/Max. 7A Per Channel Short Circuit Protection ESD Protection : 16.5Kv
Common Type	4 Points / 4COM (Single Common)
General Specification	
Power Dissipation	Max. 45mA @ 5.0Vdc
Isolation	I/O to Logic : Photocoupler isolation
Field Power	Supply Voltage : 24Vdc nominal Voltage Range : 11~28.8Vdc Power Dissipation : 5mA@28.8 Vdc / Channel
Wiring	I/O Cable Max. 2.0 mm ² (AWG 14)
Weight	70g
Module Size	12mm × 99mm × 70mm
Environment Condition	Refer to " Environment Specification"(page : 31)

3.3.12. ST-2524

Items	Specification
Output Specification	
Outputs Per Module	4 Point Source Type (Positive Logic)
Indicators	4 Green Output States, 1 Green/Red FnBUS State
Output Voltage Range	24Vdc nominal Min. 11Vdc ~ Max. 28.8Vdc
ON-state Voltage Drop	Max. 1Vdc@25°C
ON-State Min. Current	1mA Per Channel
OFF-State Leakage Current	Max. 150uA
Output Signal Delay	OFF to ON: Max. 0.3ms ON to OFF: Max. 0.3ms
Output Current Rating	Max. 2A Per Channel Max. 8A All Common
Output Protection (VNS3NV04D-E)	Over Temperature Shutdown : Min. 150°C Over Current Limit: Min. 6A/Max. 15A Per Channel Short Circuit Protection ESD Protection : 5Kv
Common Type	4 Points / 4COM (Single Common)
General Specification	
Power Dissipation	Max. 45mA @ 5.0Vdc
Isolation	I/O to Logic : Photocoupler isolation
Field Power	Supply Voltage : 24Vdc nominal Voltage Range : 11~28.8Vdc Power Dissipation : 5mA@28.8 Vdc / Channel
Wiring	I/O Cable Max. 2.0 mm ² (AWG 14)
Weight	70g
Module Size	12mm × 99mm × 70mm
Environment Condition	Refer to " Environment Specification"(page : 31)

3.3.13. ST-2614

Items	Specification
Output Specification	
Outputs Per Module	4 Point Sink Type (Negative Logic)
Indicators	4 Green Output States, 1 Green/Red FnBUS State
Output Voltage Range	24Vdc nominal Min. 11Vdc ~ Max. 28.8Vdc
ON-state Voltage Drop	Max. 0.5Vdc@25°C
ON-State Min. Current	1mA Per Channel
OFF-State Leakage Current	Max. 150uA
Output Signal Delay	OFF to ON: Max. 0.3ms ON to OFF: Max. 0.3ms
Output Current Rating	Max. 2A Per Channel Max. 8A All Common
Output Protection (VNS3NV04D-E)	Over Temperature Shutdown : Min. 150°C Over Current Limit: Min. 3.5A/Max. 7A Per Channel Short Circuit Protection ESD Protection : 16.5Kv
Common Type	4 Points / 4COM (Single Common)
General Specification	
Power Dissipation	Max. 45mA @ 5.0Vdc
Isolation	I/O to Logic : Photocoupler isolation
Field Power	Supply Voltage : 24Vdc nominal Voltage Range : 11~28.8Vdc Power Dissipation : 5mA@28.8 Vdc / Channel
Wiring	I/O Cable Max. 2.0 mm ² (AWG 14)
Weight	70g
Module Size	12mm × 99mm × 70mm
Environment Condition	Refer to " Environment Specification"(page : 31)

3.3.14. ST-2624

Items	Specification
Output Specification	
Outputs Per Module	4 Point Source Type (Positive Logic)
Indicators	4 Green Output States, 1 Green/Red FnBUS State
Output Voltage Range	24Vdc nominal Min. 11Vdc ~ Max. 28.8Vdc
ON-state Voltage Drop	Max. 1Vdc@25°C
ON-State Min. Current	1mA Per Channel
OFF-State Leakage Current	Max. 150uA
Output Signal Delay	OFF to ON: Max. 0.3ms ON to OFF: Max. 0.3ms
Output Current Rating	Max. 2A Per Channel Max. 8A All Common
Output Protection (VNS3NV04D-E)	Over Temperature Shutdown : Min. 150°C Over Current Limit: Min. 6A/Max. 15A Per Channel Short Circuit Protection ESD Protection : 5Kv
Common Type	4 Points / 4COM (Single Common)
General Specification	
Power Dissipation	Max. 45mA @ 5.0Vdc
Isolation	I/O to Logic : Photocoupler isolation
Field Power	Supply Voltage : 24Vdc nominal Voltage Range : 11~28.8Vdc Power Dissipation : 5mA@28.8 Vdc / Channel
Wiring	I/O Cable Max. 2.0 mm ² (AWG 14)
Weight	70g
Module Size	12mm × 99mm × 70mm
Environment Condition	Refer to " Environment Specification"(page : 31)

3.3.15. ST-2742

Items	Specification
Output Specification	
Outputs Per Module	2 Point
Indicators	2 Green Output States, 1 Green/Red FnBUS State
Relay type	Form A, normally Open Single Pole, Single Throw
Output Voltage Range (Load Dependent)	5~28.8Vdc @ 2.0A Resistive 48Vdc @ 0.8A Resistive 110Vdc @ 0.5A Resistive 250Vac @ 2.0A Resistive
Output Current Rating (at rated power)	2A @ 5~28.8Vdc 0.8A @ 48Vdc 0.5A @ 110Vdc 2A @ 250Vac
Min. Load	100uA, 100mVdc Per Point
Max. On-state Voltage Drop	0.5V @ 2.0A, Resistive Load, 24Vdc
Off-State Leakage Current	Max. 1.5mA
Output Signal Delay	On to Off: Max. 10ms, Off to On: Max. 10ms
Initial Contact Res.	30mΩ
Expected Contact Resistance	300K Cycles Resistive, 100K Cycles Inductive
Common Type	1 Points / 1 COM
General Specification	
Power Dissipation	Max. 65mA @ 5.0Vdc
Isolation	I/O to Logic : Photocoupler isolation
Field Power	Supply Voltage : 24Vdc nominal Voltage Range : 10~28.8Vdc
Wiring	I/O Cable Max. 2.0 mm ² (AWG 14)
Weight	65g
Module Size	12mm × 99mm × 70mm
Environment Condition	Refer to " Environment Specification"(page : 31)

3.3.16. ST-2744

Items	Specification
Output Specification	
Outputs Per Module	4 Point
Indicators	4 Green Output States, 1 Green/Red FnBUS State
Relay type	Form A, normally Open Single Pole, Single Throw
Output Range	5~28.8Vdc @ 2.0A Resistive 48Vdc @ 0.8A Resistive 110Vdc @ 0.5A Resistive 250Vac @ 2.0A Resistive
Min. Load	100uA, 100mVdc Per Point
Max. On-state Voltage Drop	0.5V @ 2.0A, Resistive Load, 24Vdc
Off-State Leakage Current	Max. 1.5mA
Output Signal Delay	On to Off: Max. 10ms, Off to On: Max. 10ms
Initial Contact Res.	20mΩ
Expected Contact Resistance	300K Cycles Resistive, 100K Cycles Inductive
Common Type	1 Points / 1 COM
General Specification	
Power Dissipation	Max. 130mA @ 5.0Vdc
Isolation	I/O to Logic : Relay Coil/Contact isolation 1250Vrms tested
Field Power	No Connection with Field Power Field Power passes through to the next module
Wiring	I/O Cable Max. 2.0 mm ² (AWG 14)
Weight	70g
Module Size	12mm × 99mm × 70mm
Environment Condition	Refer to " Environment Specification"(page : 31)

3.3.17. ST-2748

Items	Specification
Output Specification	
Outputs Per Module	8 Point
Indicators	8 Green Output States, 1 Green/Red FnBUS State
Relay type	Form A, normally Open Single Pole, Single Throw
Output Range	5~28.8Vdc @ 2.0A Resistive 48Vdc @ 0.8A Resistive 110Vdc @ 0.5A Resistive 250Vac @ 2.0A Resistive
Min. Load	100uA, 100mVdc Per Point
Max. On-state Voltage Drop	0.5V @ 2.0A, Resistive Load, 24Vdc
Off-State Leakage Current	Max. 1.5mA
Output Signal Delay	On to Off: Max. 10ms, Off to On: Max. 10ms
Initial Contact Res.	20mΩ
Expected Contact Resistance	300K Cycles Resistive, 100K Cycles Inductive
Common Type	1 Points / 1 COM
General Specification	
Power Dissipation	Max. 150mA @ 5.0Vdc
Isolation	I/O to Logic : Relay Coil/Contact isolation 1250Vrms tested
Field Power	No Connection with Field Power Field Power passes through to the next module
Wiring	I/O Cable Max. 2.0 mm ² (AWG 14)
Weight	200g
Module Size	24mm × 99mm × 70mm
Environment Condition	Refer to " Environment Specification"(page : 31)

3.3.18. ST-2792

Items	Specification
Output Specification	
Outputs Per Module	2Points with Manual/Auto Operation
Indicators	2 Green Output States,
Relay type	Form A, normally Open Single Pole, Single Throw
Output Range	5~28.8Vdc @ 2.0A Resistive 48Vdc @ 0.8A Resistive 110Vdc @ 0.5A Resistive 250Vac @ 2.0A Resistive
Max. On-state Voltage Drop	0.5V @ 2.0A, Resistive Load, 24Vdc
Output Signal Delay	On to Off: Max. 10ms, Off to On: Max. 10ms
Initial Contact Res.	20mΩ
Expected Contact Resistance	300K Cycles Resistive, 100K Cycles Inductive
Common Type	1 Points / 1 COM
General Specification	
Power Dissipation	Max. 70mA @ 5.0Vdc
Isolation	I/O to Logic : Relay Coil/Contact isolation 1250Vrms tested
Field Power	No Connection with Field Power Field Power passes through to the next module
Wiring	I/O Cable Max. 2.0 mm ² (AWG 14)
Weight	70g
Module Size	12mm × 99mm × 70mm
Environment Condition	Refer to " Environment Specification"(page : 31)

3.3.19. ST-2852

Items	Specification
Output Specification	
Outputs Per Module	2Points
Indicators	2 Green Output States, 1 Green / Red FnBUS State
Switch Type	Zero Crossing
Rated Load Voltage	15~132Vac
Output Current Rating	0.05~0.5A
Frequency Range	47~63Hz
Surge Current	40A(16mS) / 4A(30S)
Output Signal Delay	OFF to ON: Max. 0.3ms, ON to OFF : 1/ 2 Cycle + 0.3ms
On Status Voltage Drop	1.3Vrms (Max. Load)
Off-state Leakage Current	Max. 1.5mA
Common Type	2 Points / 2 COM
General Specification	
Power Dissipation	Max. 35mA @ 5.0Vdc
Isolation	between user power and Systems
Field Power	Supply Voltage : 120Vac nominal Voltage Range : 15~132Vac
Wiring	I/O Cable Max. 2.0 mm ² (AWG 14)
Weight	70g
Module Size	12mm × 99mm × 70mm
Environment Condition	Refer to " Environment Specification"(page : 31)

3.3.20. ST-2924

Items	Specification
Output Specification	
Outputs Per Module	4 Point
Indicators	4 Green Output States, 1 Green/Red Module FnBUS State
On-State Voltage Range	0...24V DC/AC nominal
On-State Voltage Drop	Max. 1.0Vdc / 3.0V ac (TBD) 24V ac/dc, 2A
Output Current Rating	Max. 2.0A per channel Max. Total Output current: Max. 8A
Output Signal Delay	Off to On: Max. 3ms (DC) / Off to On: Max. 5ms (AC) On to Off: Max. 3ms (DC) / On to Off: Max. 5ms (AC)
Frequency range	47 ~ 63Hz
Rds. (ON)	Typ.) 0.0108 Ohm, Max.) 0.0130 Ohm
Common Type	4 Points / 4 COM
General Specification	
Power Dissipation	Max. 100mA @ 5.0Vdc
Isolation	I/O to Logic : Photocoupler Isolation Isolation voltage : 2500Vrms
Field Power	Supply Voltage : 24Vac/dc nominal Voltage Range : 0~28.8Vac/dc
Wiring	I/O Cable Max. 2.0 mm ² (AWG 14)
Weight	70g
Module Size	12mm × 99mm × 70mm
Environment Condition	Refer to " Environment Specification"(page : 31)

3.3.21. ST-2944

Items	Specification
Output Specification	
Outputs Per Module	4 Point
Indicators	4 Green Output States, 1 Green/Red Module FnBUS State
On-State Voltage Range	0...24V DC/AC nominal
On-State Voltage Drop	Max. 1.0Vdc / 3.0V ac (TBD) 24V ac/dc, 2A
Output Current Rating	Max. 2.0A per channel Max. Total Output current: Max. 8A
Output Signal Delay	Off to On: Max. 3ms (DC) / Off to On: Max. 5ms (AC) On to Off: Max. 3ms (DC) / On to Off: Max. 5ms (AC)
Frequency range	47 ~ 63Hz
Rds. (ON)	Typ.) 0.0108 Ohm, Max.) 0.0130 Ohm
Common Type	1 Points / 1 COM
General Specification	
Power Dissipation	Max. 100mA @ 5.0Vdc
Isolation	I/O to Logic : Photocoupler Isolation Isolation voltage : 2500Vrms
Field Power	Supply Voltage : 24Vac/dc nominal Voltage Range : 0~28.8Vac/dc
Wiring	I/O Cable Max. 2.0 mm ² (AWG 14)
Weight	70g
Module Size	12mm × 99mm × 70mm
Environment Condition	Refer to " Environment Specification"(page : 31)

3.3.22. ST-2734

Items	Specification
Output Specification	
Outputs Per Module	4 Point
Indicators	4 Green Output States, 1 Green/Red Module FnBUS State
On-State Voltage Range	0...220V DC/AC nominal 24V AC/DC, Max. 0.5A(TBD) 110V AC/DC, Max. 0.5A(TBD) 220V AC/DC, Max. 0.5A(TBD)
On-State Voltage Drop	Max. 110V : 1.0V dc / 2.0V ac, 110V ac/dc, 0.5A Max. 220V : 1.0V dc / 2.0V ac, 220V ac/dc, 0.5A
Output Current Rating	Max. 2.0A per channel Max. Total Output current: Max. 8A
Output Signal Delay	Off to On: Max. 3ms (DC) / Off to On: Max. 5ms (AC) On to Off: Max. 3ms (DC) / On to Off: Max. 5ms (AC)
Frequency range	47 ~ 63Hz
Rds. (ON)	Typ.) 0.0108 Ohm, Max.) 0.0130 Ohm
Common Type	4 Points / 4 COM
General Specification	
Power Dissipation	Max. 100mA @ 5.0Vdc
Isolation	I/O to Logic : Photocoupler Isolation Isolation voltage : 2500Vrms
Field Power	Supply Voltage : 24Vac/dc nominal Voltage Range : 0~28.8Vac/dc
Wiring	I/O Cable Max. 2.0 mm ² (AWG 14)
Weight	70g
Module Size	12mm × 99mm × 70mm
Environment Condition	Refer to " Environment Specification"(page : 31)

4. Dimension

4.1. ST-2xx2, ST-2xx4, ST-2xx8

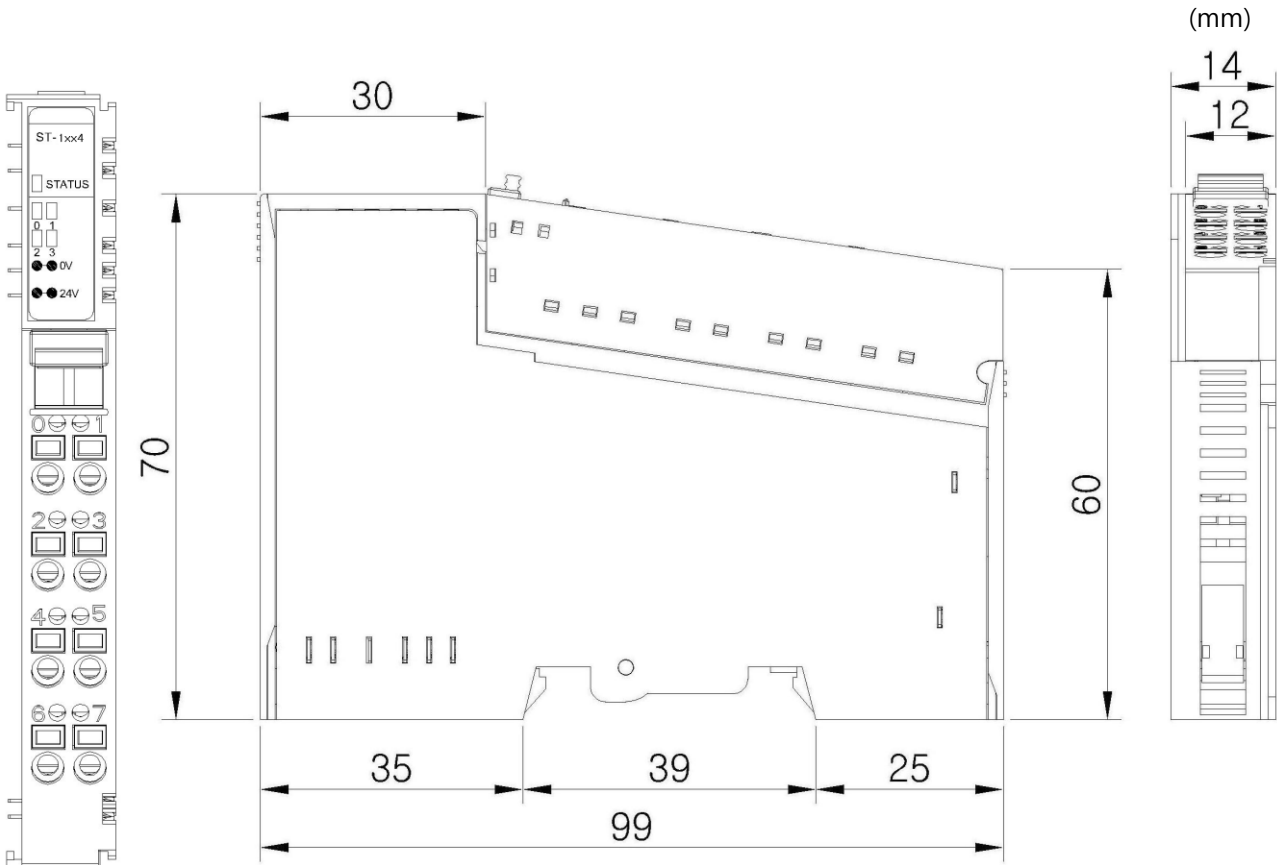

4.2. ST-2xxF

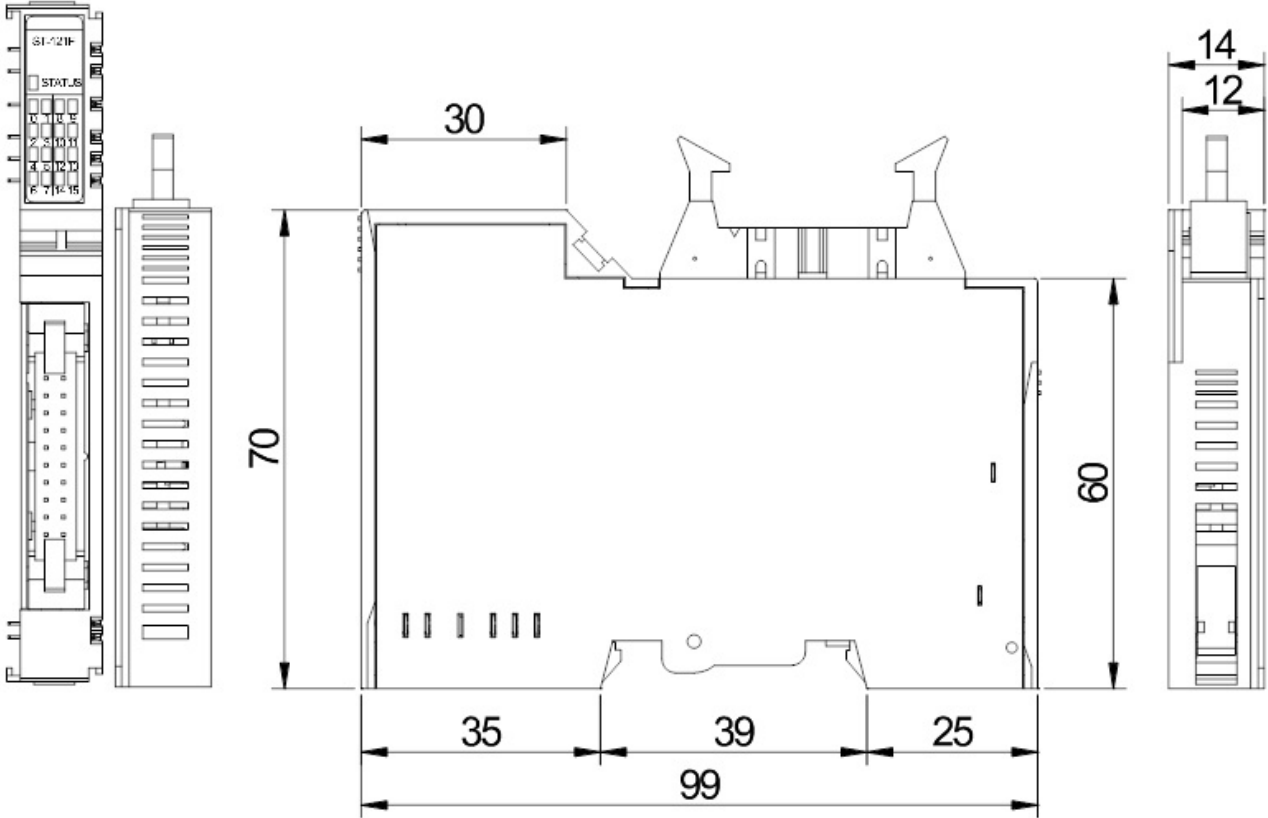

5. Mapping Data into the image Table

5.1. ST-2742, ST-2852

Output Image Value

Bit No	Bit 7	Bit 6	Bit 5	Bit 4	Bit 3	Bit 2	Bit 1	Bit 0
Byte 0	Reserved						D1	D0



Output Module Data

D1	D0
----	----

5.2. ST-2xx4

Output Image Value

Bit No	Bit 7	Bit 6	Bit 5	Bit 4	Bit 3	Bit 2	Bit 1	Bit 0
Byte 0	Reserved				D3	D2	D1	D0



Output Module Data

D3	D2	D1	D0
----	----	----	----

5.3. ST-2xx8

Output Image Value

Bit No	Bit 7	Bit 6	Bit 5	Bit 4	Bit 3	Bit 2	Bit 1	Bit 0
Byte 0	D7	D6	D5	D4	D3	D2	D1	D0



Output Module Data

D7	D6	D5	D4	D3	D2	D1	D0
----	----	----	----	----	----	----	----

5.4. ST-2xxF

Output Image Value

Bit No	Bit 7	Bit 6	Bit 5	Bit 4	Bit 3	Bit 2	Bit 1	Bit 0
Byte 0	D7	D6	D5	D4	D3	D2	D1	D0
Byte 1	D15	D14	D13	D12	D11	D10	D9	D8



Output Module Data

D7	D6	D5	D4	D3	D2	D1	D0
D15	D14	D13	D12	D11	D10	D9	D8

5.5. ST-2792

IO Input Image data
– 2bytes

Bit No	Bit 7	Bit 6	Bit 5	Bit 4	Bit 3	Bit 2	Bit 1	Bit 0
Byte 0							OUT#1	OUT#0
	Auto / Manual detection							
	00b : OUT#1 Auto / OUT#0 Auto							
	01b : OUT#1 Auto / OUT#0 Manual							
	10b : OUT#1 Manual / OUT#0 Auto							
11b : OUT#1 Manual / OUT#0 Manual								
Byte 1							OUT#1	OUT#0
	Manual Status detection(both channels in Auto means normally off)							
	00b : OUT#1 OFF / OUT#0 OFF							
	01b : OUT#1 OFF / OUT#0 ON							
	10b : OUT#1 ON / OUT#0 OFF							
11b : OUT#1 ON / OUT#0 ON								

IO Output Image Data
– 1byte

Bit No	Bit 7	Bit 6	Bit 5	Bit 4	Bit 3	Bit 2	Bit 1	Bit 0
Byte 0							OUT#1	OUT#0

IO Output Image Data
– 2bytes

Bit No	Bit 7	Bit 6	Bit 5	Bit 4	Bit 3	Bit 2	Bit 1	Bit 0
Byte 0							Fault Action#1	Fault Action#0
Byte 1							Fault Action#1	Fault Action#0

Fault Action#0, 1 = 0: Fault Value (Default), 1: Hold Last state

Fault Value#0, 1 = 0: OFF (Default), 1: ON

Important, the “Fault Action” is only active if the output is in “Auto” mode. The manual status always overrides the selected “Fault Action” on the output.

6. Trouble Shooting

ATTENTION



In this manual, it couldn't be described all variety case with Network Adapter of several protocols. So if you couldn't find any fault after investigating all below cases, refer to NA user manual.

6.1. Normal Module

LED Status	Cause	Action	
EXPANSION MODULE STATUS LED	Not Power	Device has no expansion Module or may not be powered	
	No Initialized	The Parameter is not initialized yet.	
	Green	Fn-Bus Connection	FnBus normal Operation
	Flashing Green	Fn-Bus Ready	FnBus ready
	Flashing Red	Fn-Bus Fault	FnBus Time Out, FnBus Failed Communication
	Red	Device Fault	Device fault
CHANNEL STATUS LED			
	Not Signal	Normal Operation	
	On Signal	Normal Operation	

6.2. ST-2792 Switches(Channel 0, Channel 1)

Switch is	Status	Description
AUTO	AUTO	
OFF	Manual Output OFF	
ON	Manual Output ON	