

Multi-Messenger USB
by
Audio Messaging Solutions
Installation & User Manual

Index:

| | |
|---|-------|
| Introduction | 3 |
| Multi-Messenger USB Layout Summary..... | 4 - 5 |
| Installation | 6 - 9 |
| Message Programming & Operation..... | 10 |
| Warranty & FCC | 11 |

Introduction:

The Multi-Messenger USB is a solid-state digital message repeater that installs easily into any messaging application that requires a continuous, timed or triggered message play. Up to 99 messages in the MP3 format can be stored on industry standard USB flash drives and triggered by the eight triggered inputs or a built-in timer circuit.

Unpacking and Inspection:

Before you begin installation, unpack and verify you have all the correct parts.

- (1) Multi-Messenger USB
- (1) USB flash drive
- (2) 10-pin screw-down connectors
- (1) 12VDC @ 500mA power supply
- (1) Instruction manual
- (1) Slotted screwdriver
- (2) RCA to fly leads cable
- (4) Wall mount screws
- (4) Rubber feet

If you are missing any of these parts STOP and call your dealer.

Additional tools or supplies (not supplied).

- (1) Phillips screwdriver
- (1) Wire strippers
- (1) Shielded 22 or 24 gauge wire for wiring screw-down connectors.

Multi-Messenger USB Layout Summary:

Front of Unit

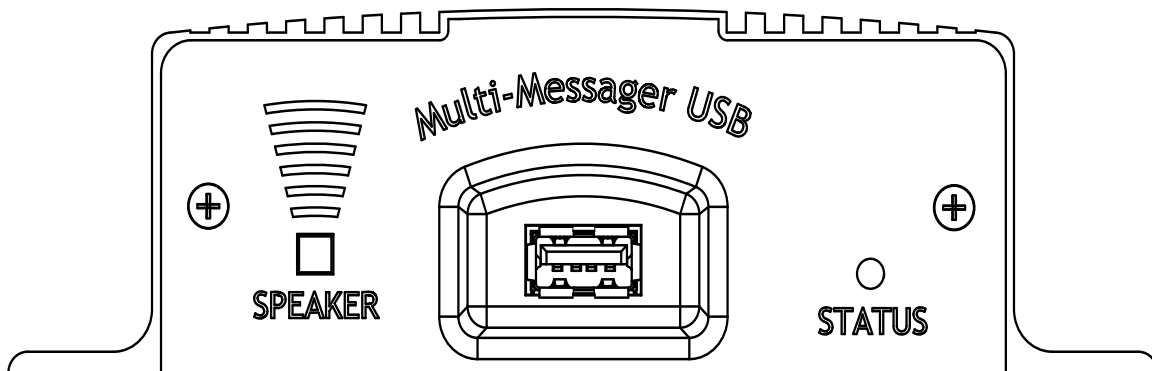

SPEAKER - The SPEAKER switch can be turned ON and OFF to monitor audio. The switch has no effect on the audio output connections on the rear of the unit. Switch should normally be kept OFF.

USB PLUG - The USB drive is inserted here to play audio. If insertion of drive is difficult, turn the drive over and try reinserting. Drive should slide into jack smoothly.

STATUS - The STATUS indicator is a LED that during normal operation with a USB drive inserted into the unit will be SOLID BLUE. If there is a problem with the drive, it is not inserted or it is empty, the LED will BLINK BLUE.

Rear of Unit

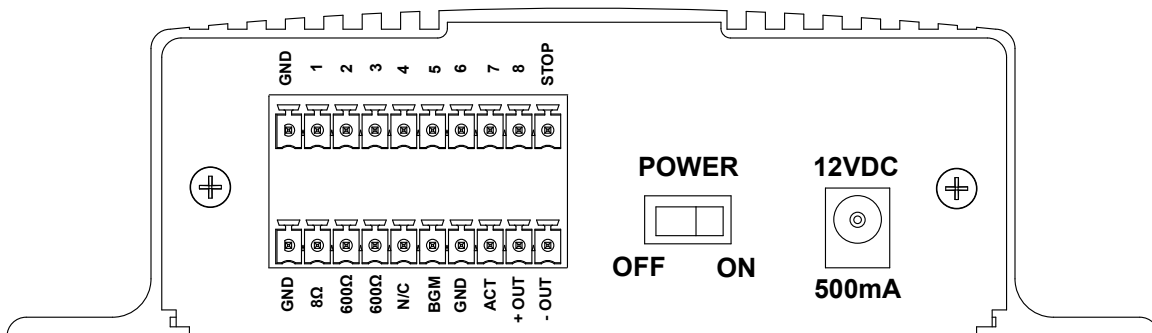

I/O BLOCK - This 20-pin modular header accepts two 10-pin screw-down socket blocks that are included in the accessory pack. For further instructions turn to page 6.

POWER - Use this switch to turn the unit ON and OFF.

12VDC - This is where the supplied 12VDC @ 500mA power pack is connected.

Bottom of unit

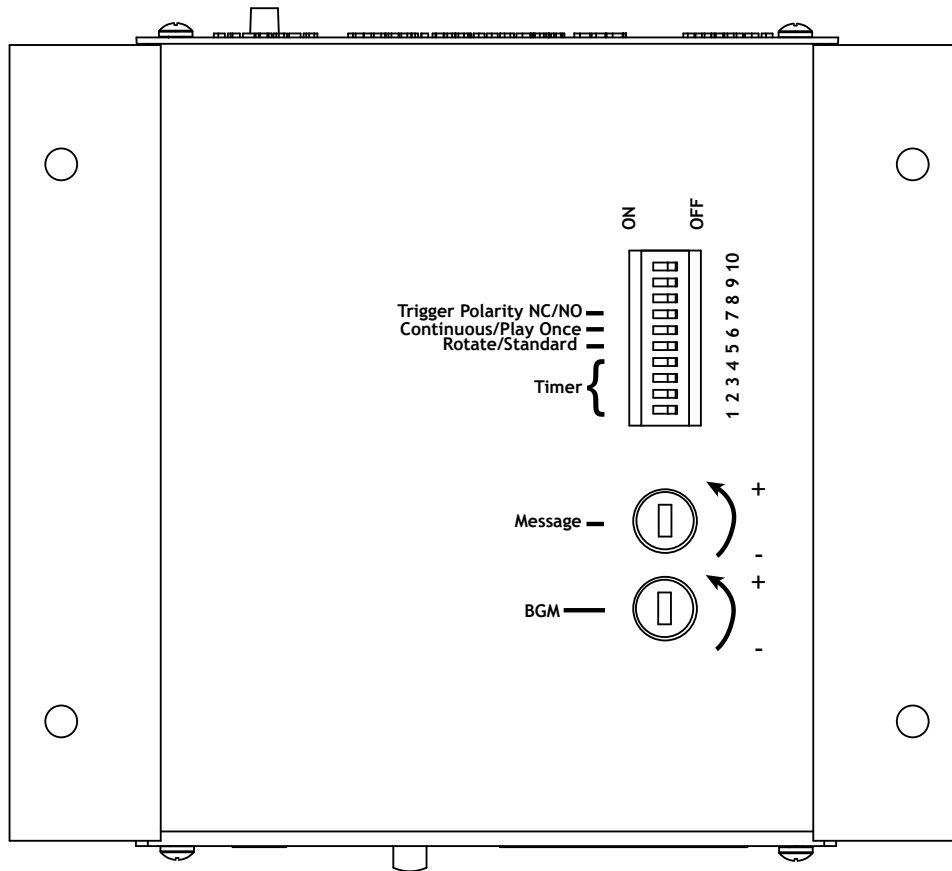

BGM - This pot is used to control the final output level of the background music that is fed through the units BGM INPUT on the I/O CONNECTOR on the rear of the unit. Volume up is counter-clockwise, volume down is clockwise.

MESSAGE - This pot is used to control the final output level of the stored messages. Volume up is counter-clockwise, volume down is clockwise.

TIMER - These multiple DIP switch positions; SW1 to SW4 are used to configure the stored message timer for message slots 9 through 99.

ROTATE/ STANDARD - This single DIP switch position; SW5 is used to select the standard or rotate message feature for message slots 1 through 8.

CONTINUOUS TRIGGER/PLAY ONCE - This single DIP switch position; SW6 is used to select the play once or continuous trigger feature for message slots 1 through 8 ONLY.

TRIGGER NC/NO - This single DIP switch position; SW7 is used to select the trigger polarity of the incoming contact closure on the I/O CONNECTOR.

UNUSED - DIP switches SW8, SW9 & SW10 are not used.

A full explanation of these settings can be found in the PROGRAMMING section of this manual.

Installation:

The Multi-Messenger should be installed using the following steps outlined below:

Step 1: Wire the terminal blocks that are supplied with the kit.

Use the chart below to wire the terminal blocks for the features that are applicable to your application. Two terminal blocks, two RCA audio cords and a screwdriver have been supplied in the accessory kit.

The TRIGGER & STOP terminals should use single or multi-conductor shielded 22 or 24 gauge wire.

The 8Ω, 600Ω and BGM connections should use the RCA to fly leads cable supplied in the accessory kit.

The ACTIVE TRIGGER output & 12VDC auxiliary power out should use 22 or 24 gauge wire.

The ACTIVE TRIGGER output is rated at 25mA. A relay is required if 25mA will be exceeded.

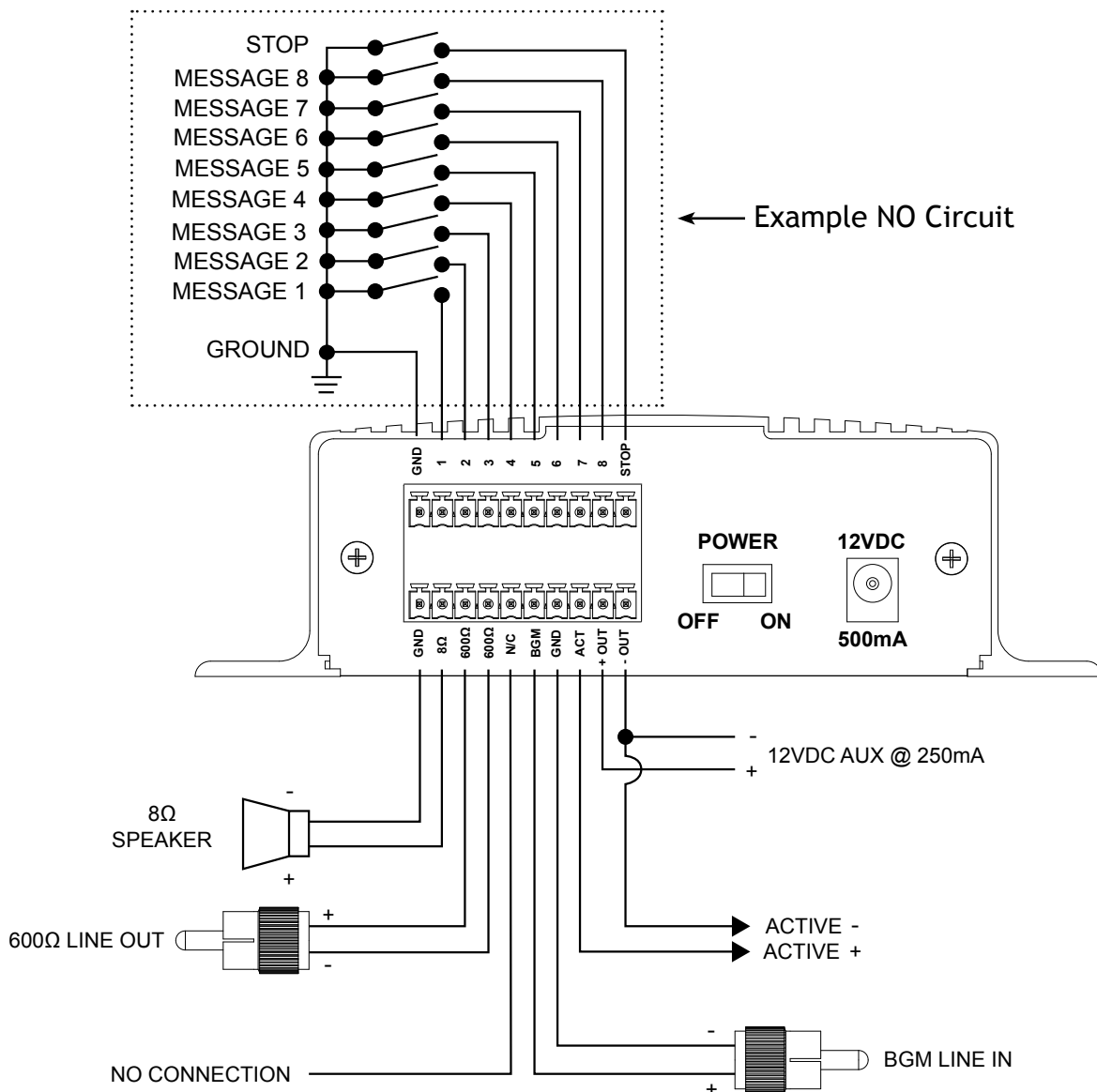

Step 2: Set the DIP switches for the features that will be used.

The Mutli-Messenger USB has several features that are activated by setting the DIP switches on the bottom of the unit. Changes to these DIP switches must be done with the power OFF.

TIMER - These multiple DIP switch positions; SW1 to SW4 are used to configure the stored message timer for message slots 9 through 99. Use the chart below to configure the timer, if no timer is required turn all switches to the OFF position.

| Time Interval | SW1 | SW2 | SW3 | SW4 |
|---------------|-----|-----|-----|-----|
| Timer OFF | OFF | OFF | OFF | OFF |
| 10 seconds | ON | OFF | OFF | OFF |
| 20 seconds | OFF | ON | OFF | OFF |
| 30 seconds | ON | ON | OFF | OFF |
| 45 seconds | OFF | OFF | ON | OFF |
| 1 minute | ON | OFF | ON | OFF |
| 2 minutes | OFF | ON | ON | OFF |
| 3 minutes | ON | ON | ON | OFF |
| 4 minutes | OFF | OFF | OFF | ON |
| 5 minutes | ON | OFF | OFF | ON |
| 10 minutes | OFF | ON | OFF | ON |
| 15 minutes | ON | ON | OFF | ON |
| 20 minutes | OFF | OFF | ON | ON |
| 30 minutes | ON | OFF | ON | ON |
| 45 minutes | OFF | ON | ON | ON |
| 60 minutes | ON | ON | ON | ON |

For example: Slots 10, 25, & 50 have messages, AND the switch settings on the bottom of the unit are set for 10 minutes. During normal operation triggered messages will play on demand, but every 10 minutes ONE of the timed messages will play . . . first slot 10 will play then wait 10 minutes . . . then slot 25 will play . . . wait 10 minutes . . . then slot 50 . . . wait 10 minutes . . . then slot 10 . . . and so on. If BGM music is used, then it will fade down to play the message then fade back up after the message is played.

ROTATE/STANDARD - This DIP switch position SW5 is used to select the standard or rotate message feature for message slots 1 through 8.

When this DIP switch is set to "ON" the unit will rotate through the messages on each triggering of input TRIGGER 1. For example, the first time TRIGGER 1 is activated message 1.mp3 will play, the next time TRIGGER 1 is activated message 2.mp3 will play, and so on. Triggering of TRIGGER 2 through 8 will have no effect.

When this DIP switch is set to "OFF" the unit will trigger normally - Normally is defined as any one of the eight contact closures that are activated will trigger the corresponding message. Example TRIGGER 1 will play message 1.mp3, TRIGGER 2 will play message 2.mp3, and so on. The unit has 8 triggered inputs.

Note: If you only have one message on the unit then STANDARD or ROTATE will have the same effect.

CONTINUOUS TRIGGER/PLAY ONCE - This DIP switch position SW6 is used select the play once or continuous trigger feature for message slots 1 through 8 ONLY.

When this DIP switch is set to “ON” the unit will play message selected continuously, as long as trigger is applied.

When this DIP switch is set to “OFF” the unit will play message selected once, then stop until triggered again.

Note: This has no effect on message slots 9 through 99.

TRIGGER NC/NO - This single DIP switch position SW7 is used to select the trigger polarity of the incoming contact on the I/O CONNECTOR.

When this DIP switch is set to “ON” all incoming triggers are set to normally-closed triggering. The unit will play a message when the trigger input is lifted from ground. The unit will also STOP playing the current message if the STOP TRIGGER is lifted from ground.

When this DIP switch is set to “OFF” all incoming triggers are set to normally-open triggering. The unit will play a message when the TRIGGER input for that specific message is brought to ground. The unit will also STOP playing the current message if the STOP TRIGGER is brought to ground.

Important note for normally-closed triggering : When using normally-closed triggering, all trigger inputs including the stop trigger must be tied to ground. Failure to do so will cause undesired operation.

UNUSED - DIP switches SW8, SW9 & SW10 are not used.

Step 3: Install Multi-Messenger USB hardware

Step 1: Wall or shelf mount the unit. Screws and rubber feet are supplied in the accessory kit.

Step 2: Verify power switch on rear of unit is in OFF position. Attach the included power pack to a wall or power strip receptacle, then attach the other end to the jack on the rear of the unit labeled 12VDC.

Tip: Make sure the power receptacle is live 24 hours a day and is not switched off at night.

Step 3: If connecting unit to an amplifier make sure it is turned OFF for this part of the installation.

Step 4: Connect the 10-pin socket blocks to the headers on the rear of the unit. This wiring should have been done in a previous step - if not completed go to the WIRING DIAGRAM section of this manual.

Warning: Connection of a P. A. amplifiers OUTPUT to any connections on this unit will cause damage and void the warranty.

Step 5: Insert the USB flash drive into the front of the unit. Do not force the USB flash drive - if it does not fit in one way, try turning it over and reinserting.

Step 6: Turn the power switch on rear of unit to the ON position. After the unit initializes the STATUS LED on the front of unit will turn solid blue. This process may take up to 15 seconds.

Step 7: Push the SPEAKER switch located on the front of the unit to the IN position. This speaker is for verifying audio playback and testing purposes only – DO NOT use this for setting the OUTPUT volume level!

Step 8: If any amplifiers were turned OFF during installation turn them back ON now.

Step 9: If a background music source is not being fed through the unit then skip to the next step. Adjust the volume level pot labeled BGM on the bottom of the unit using the included screwdriver. DO NOT use the internal speaker on the unit to set this level - listen to the speaker(s) connected to the output of the unit or output of the P. A. amplifier .

If an acceptable volume level can not be achieved or audio is distorted/muffled, then take the following steps:

- a. Turn down (clockwise) the pot labeled BGM on the bottom of the unit.
- b. Turn the volume level UP on the stores PA amplifier.
- c. Turn up (counter-clockwise) the pot labeled BGM on the bottom of the unit.
- d. Keep repeating above procedure until level is acceptable or go to step e.
- e. Move the RCA plug from the 8Ω to 600Ω or 600Ω to 8Ω output on the rear of the unit.
- f. Repeat step a through d.

Step 10: Push the SPEAKER switch to the OUT position.

Step 11: Trigger one of the stored messages either by contact closure or timed message interval. If volume levels are low or high, the pot labeled MESSAGE on the bottom of the unit may need to be adjusted. MESSAGE volume down is clockwise, MESSAGE volume up is counter-clockwise.

Message Programming & Operation:

All messages that are available for the Multi-Messenger USB to play are stored on an industry standard USB flash drive. Messages must be labeled correctly so they will automatically be placed into virtual message “slots” on the unit. There are two different type of message slots:

1. Triggered Message Slots – These messages reside in slots 1 to 8 of the USB flash drive and are activated instantly when the corresponding contact closure is activated.
2. Timed Message Slots – These messages reside in slots 9 – 99 of the USB flash drive and are activated by a built-in timer circuit.

Messages are placed onto the USB flash drive using a standard computer and dragging and dropping new audio from the computer to the USB flash drive.

Messages MUST be labeled in the following manner: “slot position_number”.mp3

For example, if you wanted a file named “sound_effect.mp3” put into slot eight, then it would need to be renamed as file “8.mp3”.

A typical list of messages on the USB flash drive would look like this:

1.mp3
2.mp3
8.mp3
10.mp3
36.mp3

The above list would allow messages 1.mp3, 2.mp3 & 8.mp3 to be triggered by the contact closures while 10.mp3 and 36.mp3 would be played on a time interval. The time interval would be set with the DIP switches on the bottom of the unit.

If the USB drive ever needs to be erased completely then it can be formatted using your computer. Drives smaller than 512MB can be formatted using FAT, and drives 512MB or larger can use FAT32.

Limited Warranty

TERMS: Audio Messaging Solutions warrants to the original purchaser (“Buyer”) that the Product sold is free from defects in material and workmanship at the time of purchase. The warranty period begins at the time of Product’s original purchase by the first end-user. The warranty applies for five (5) year from the original date of purchase, or as long as the product is owned by the original purchaser, whichever comes first. Included in the warranty are parts and labor. Buyer must provide written notice to Audio Messaging Solutions of any defective part or conditions within the warranty period. If the defect is not the result of improper use, service, maintenance or installation, and if the equipment has not been otherwise damaged or modified after shipment, Audio Messaging Solutions or its authorized representative shall either replace or repair the defective Product at Audio Messaging Solutions’s option. No credit shall be allowed for work performed by Buyer or unauthorized parties. Out-of-warranty repairs are invoiced at the current Audio Messaging Solutions hourly rate plus the cost of parts, shipping and handling. In the event that the product serial number is missing or has been tampered with in any way, the foregoing warranty is void and without effect and Audio Messaging Solutions shall have no liability whatsoever on account of defects to such product.

LIMITATIONS: Except as stated above, there are no warranties, express or implied, that extend beyond the specifications for the product. Audio Messaging Solutions expressly disclaims any warranty, express or implied, that equipment sold hereunder is of merchantable quality or that it can be used, or is fit for any particular purpose. Buyer purchases and accepts equipment solely on the basis of the warranty here in above expressed. Under no circumstances shall Audio Messaging Solutions be liable by virtue of this warranty or otherwise for any special indirect, secondary or consequential damages to any person or property arising out of the use or inability to use the product.

REPAIRING OR REPLACING PRODUCT: Buyer may obtain the repair or replacement of any eligible part or equipment covered under this warranty through a Audio Messaging Solutions dealer only. Buyer is responsible for all shipping and handling charges in connection with the performance of this warranty. Products returned to Audio Messaging Solutions must be securely packaged to prevent damage in transit, freight prepaid, and insured for replacement value. A return authorization number assigned by Audio Messaging Solutions must be clearly marked on the outside of the shipping container. Proof of purchase must accompany shipment. Items delivered to Audio Messaging Solutions without a return authorization clearly marked on the outside of the shipping container, and/or without proof of purchase is refused.

CONTACT: Please contact Audio Messaging Solutions at the address and phone number below to receive a return authorization number and to arrange for the repair or replacement of a flawed part covered by this warranty. Please indicate the Product’s serial number in all correspondence or a RMA authorization number in the absence of a serial number. Audio Messaging Solutions, 720 Brooker Creek Blvd., Oldsmar, FL 34677, Phone: 1.800.584.4653.

COPYRIGHT NOTICE: The Audio Messaging Solutions Multi-Messenger USB is strictly used for Licensed Music only. Use of copyrighted music is illegal and Audio Messaging Solutions, Inc. takes no responsibility for that action.

FCC Part 15 : This equipment has been tested and found to comply within the limits for a Class A digital device, pursuant to Part 15 of the FCC rules. These limits are designed to provide reasonable protection against harmful interference when the equipment is operated in a commercial environment. This equipment generates, uses and can radiate radio frequency energy and, if not installed and used in accordance with the instruction manual, may cause harmful interference to radio communications. Operation of the equipment in a residential area is likely to cause harmful interference in which case the user will be required to correct interference at his own expense. In order to maintain compliance with FCC regulations shielded cables must be used with this equipment. Operation with non-approved equipment or unshielded cables is likely to result in interference to radio & television reception.

Changes or modifications not expressly approved by Audio Messaging Solutions could void the users’ authority to operate the equipment.

IC ES 003 : This Class A digital apparatus complies with Canadian ICES-003 C et appareil numérique de la classe A est conforme à la norme NMB-003 du Canada.

CE CONFORMITY : The Audio Messaging Solutions Multi-Messenger USB conforms with the following standards, in accordance with the EU Safety, EMC Emissions, & EMC Immunities : EN 60950-1:2001, EN 55022:1998 for Class A, EN 55024:1998 + A1:2001 + A2:2003, EN 61000-4-2:1995 + A1:1998, EN 61000-4-3:1995, EN 61000-4-4:1995, EN 61000-4-5:1995, EN 61000-4-6:1996, EN 61000-5-11:1994.





Audio Messaging
Solutions, LLC

720 Brooker Creek Blvd., Ste. 215
Oldsmar, FL 34677

1.800.584.HOLD (4653)
<http://onholdbusiness.com>
info@onholdbusiness.com

Rev. A - 02/07

Copyright © Audio Messaging Solutions