

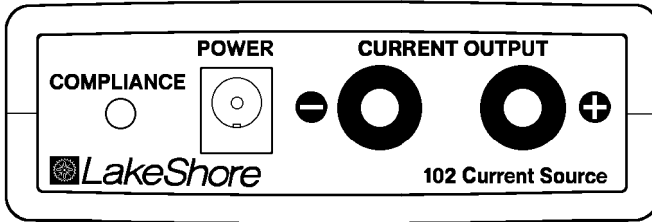

User's Manual

Model 102 Current Source



Lake Shore Cryotronics, Inc.
575 McCorkle Boulevard
Westerville, Ohio 43082-8888 USA

E-Mail Addresses:
sales@lakeshore.com
service@lakeshore.com

Internet Addresses:
www.lakeshore.com

Fax: (614) 891-1392
Telephone: (614) 891-2243

Methods and apparatus disclosed and described herein have been developed solely on company funds of Lake Shore Cryotronics, Inc. No government or other contractual support or relationship whatsoever has existed which in any way affects or mitigates proprietary rights of Lake Shore Cryotronics, Inc. in these developments. Methods and apparatus disclosed herein may be subject to U.S. Patents existing or applied for. Lake Shore Cryotronics, Inc. reserves the right to add, improve, modify, or withdraw functions, design modifications, or products at any time without notice. Lake Shore shall not be liable for errors contained herein or for incidental or consequential damages in connection with furnishing, performance, or use of this material.

LIMITED WARRANTY

Lake Shore Cryotronics, Inc. (henceforth Lake Shore), the manufacturer, warrants this product to be free from defects in material and workmanship for a period of 12 months from the date of shipment. During the warranty period, under authorized return of instruments or component parts to Lake Shore freight prepaid, the company will repair, or at its option replace, any part found to be defective in material or workmanship, without charge to the Owner for parts, service labor, or associated customary shipping cost. Replacement or repaired parts will be warranted for only the unexpired portion of the original warranty or 90 days (whichever is greater).

All products are thoroughly tested and calibrated to published specifications prior to shipment. Calibration Certifications are offered for 12-month periods only. Where such documentation must be updated, a re-certification service is offered by Lake Shore at a reasonable cost.

LIMITATION OF WARRANTY

This warranty is limited to Lake Shore products purchased and installed in the United States, or Internationally through our approved distribution agents. This same protection will extend to any subsequent owner during the warranty period. It does not apply to damage resulting from improper or inadequate maintenance, unauthorized modification or misuse, or operation outside of the environmental specifications. It does not apply to damage caused by accident, misuse, fire, flood, or acts of God, or from failure to properly install, operate, or maintain the product in accordance with the printed instruction provided.

This warranty is in lieu of any other warranties, expressed or implied, including merchantability or fitness for a particular purpose, which are expressly excluded. The owner agrees that Lake Shore's liability with respect to this product shall be set forth in this warranty, and incidental or consequential damages are expressly excluded.

CERTIFICATION

Lake Shore certifies that this product has been inspected and tested in accordance with its published specifications and that this product met its published specifications at the time of shipment. The accuracy and calibration of this product at the time of shipment are traceable to the United States National Institute of Standards and Technology (NIST); formerly known as the National Bureau of Standards (NBS), or to a recognized natural standard.

TRADEMARK ACKNOWLEDGEMENT

Manufacturers and sellers claim many designations as trademarks to distinguish their products. Where those designations appear in this manual and Lake Shore was aware of a trademark claim, the designations appear in initial capital letters with a [™] or [®] symbol.

Apiezon[®] is a trademark of Biddle Instruments.

CalCurve[™], Carbon-Glass[™], Cernox[™], Duo-Twist[™],
High-Temperature Cernox[™], Quad-Lead[™], Quad-Twist[™], Rox[™],
SoftCal[™], and Thermox[™] are trademarks of Lake Shore Cryotronics, Inc.

Teflon[®] is a trademark of DuPont De Nemours.

Copyright © 1993, 1997, 1999, and 2002 by Lake Shore Cryotronics, Inc. All rights reserved. No portion of this manual may be reproduced, stored in a retrieval system, or transmitted, in any form or by any means, electronic, mechanical, photocopying, recording, or otherwise, without the express written permission of Lake Shore.

TABLE OF CONTENTS

<i>Chapter/Paragraph</i>	<i>Title</i>	<i>Page</i>
1	INTRODUCTION.....	1-1
1.0	General	1-1
1.1	Model 102 System Description.....	1-1
1.2	Handling Liquid Helium and Liquid Nitrogen	1-3
1.2.1	Handling Cryogenic Storage Dewars.....	1-3
1.2.2	LHe and LN ₂ Safety Precautions	1-3
1.2.3	Recommended First Aid	1-4
1.3	Electrostatic Discharge.....	1-4
1.3.1	Identifying ESDS Components	1-5
1.3.2	Handling ESDS Components	1-5
1.4	Safety Summary.....	1-5
1.5	Safety Symbols	1-6
2	INSTALLATION.....	2-1
2.0	General	2-1
2.1	Inspection and Unpacking	2-1
2.2	Repackaging For Shipment.....	2-1
2.3	Power and Ground Requirements.....	2-2
2.4	Sensor Installation Recommendations	2-2
2.4.1	Connecting Leads to the Sensor	2-3
2.4.2	Sensor Mounting.....	2-3
2.4.3	Measurement Errors Due To AC Noise	2-4
3	OPERATION.....	3-1
3.0	General	3-1
3.1	Front Panel Features and Functions	3-1
3.2	Operational Notes	3-2
4	SERVICE	4-1
4.0	General	4-1
4.1	Output Current Programming	4-1
4.2	Calibration	4-1
4.2.1	Current Calibration Using DC Amp Range	4-2
4.2.2	Current Calibration Using DC Volt Range.....	4-3

LIST OF ILLUSTRATIONS

<i>Figure No.</i>	<i>Title</i>	<i>Page</i>
1-1	Typical Cryogenic Storage Dewar	1-3
3-1	Model 102 Front Panel	3-2
3-2	Typical Model 102 Application	3-2
4-1	Model 102 PCB Layout.....	4-2

LIST OF TABLES

<i>Table No.</i>	<i>Title</i>	<i>Page</i>
1-1	Model 102 Specifications.....	1-2

CHAPTER 1

INTRODUCTION

1.0 GENERAL

Lake Shore Cryotronics designed and manufactured the Model 102 Current Source in the USA. This chapter covers a general description in Paragraph 1.1, Handling Liquid Helium and Liquid Nitrogen in Paragraph 1.2, Electrostatic Discharge in Paragraph 1.3, Safety Summary in Paragraph 1.4, and Safety Symbols in Paragraph 1.5.

We welcome comments on this manual. Although we try to keep it error-free, some may occur. To report an error, describe it briefly and include the appropriate paragraph, figure, table, and page number. Send comments to Lake Shore Cryotronics, Attn: Technical Publications, 575 McCorkle Blvd., Westerville, Ohio 43082-8888. This manual is subject to change without notice.

1.1 MODEL 102 GENERAL DESCRIPTION

The Model 102 is a precision DC current source which provides excellent performance at low cost. The factory pre-sets output current to 10 μA , but the unit may be reprogrammed at any value between 1 μA and 1 mA by changing a resistor inside the instrument.

The Model 102 has a compliance voltage of 8 Volts, allowing it to be used as an excitation source in a variety of diode sensor applications. A compliance LED visually indicates unit operation within specification.

The Model 102 provides a constant current through the load (sensor) connected across the output terminals. It monitors the voltage across the sensor and derives a corresponding temperature from the response curve supplied with the sensor.

An external AC wall-mount transformer supplies power to the unit. There are two 12 VAC wall mount transformers available for the Model 102: a 120 VAC to 12 VAC transformer for a 90 – 130 VAC input, and a 220 VAC to 12 VAC transformer for a 200 – 250 VAC input. Specify the supply type to match the AC line voltage when ordering.

Table 1-1. Model 102 Specifications

Output Current: 10 μ A factory set; internally programmable from 1 μ A to 1 mA.

Accuracy: 0.05% of output at 10 μ A

Temperature Coefficient: 0.005% per $^{\circ}$ C

Compliance Voltage: 8 volts

AC Current Ripple: Less than 0.01% of scale +1 nA (RMS) in a properly shielded system

Line Regulation: Less than 0.01% change in output for 10% change in line voltages within specified range

Load Regulation: Less than 0.01% change in output current from 1 to 100% of compliance voltage

Connections: Current output via standard banana jacks

Ambient Temperature Range: 15 – 35 $^{\circ}$ C (59 – 95 $^{\circ}$ F)

Power: 90 – 125 or 210 – 250 VAC, 50/60 Hz,
External Wall Mount AC Transformer

Size: 95 \times 33 \times 158 mm (3.7 \times 1.3 \times 6.2 inches)

Weight: 0.3 kilograms (0.7 pounds)

NOTES

1. Product Specifications are subject to change without notice.
2. The electrical specifications given are for a unit operating at the factory at current output of 10 μ A; a different output current may affect some specifications.

1.2 HANDLING LIQUID HELIUM AND LIQUID NITROGEN

Helium and Nitrogen are colorless, odorless, and tasteless gases. They liquefy when properly cooled. Liquid Helium (LHe) and liquid nitrogen (LN₂) may be used in conjunction with the Model 102. Although not explosive, there are certain safety considerations in the handling of LHe and LN₂.

1.2.1 Handling Cryogenic Storage Dewars

Operate all cryogenic containers (dewars) in accordance with manufacturer instructions. Safety instructions are normally posted on the side of each dewar. Keep cryogenic dewars in a well-ventilated place, protected from the weather, and away from heat sources. Figure 1-1 shows a typical cryogenic dewar.

1.2.2 LHe and LN₂ Safety Precautions

Transfer LHe and LN₂ and operate storage dewar controls in accordance with manufacturer/supplier instructions. During transfer, follow all safety precautions written on the storage dewar and recommended by the manufacturer.

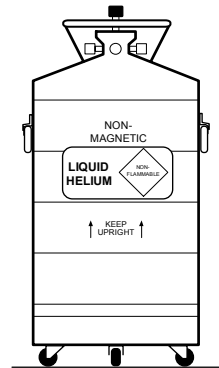

Figure 1-1. Typical Cryogenic Dewar

WARNING

- **Liquid helium is a potential asphyxiant and can cause rapid suffocation without warning. Store and use in an adequately ventilated area. DO NOT vent the container in confined spaces. DO NOT enter confined spaces where gas may be present unless area is well-ventilated. If inhaled, remove to fresh air. If not breathing, give artificial respiration. If breathing is difficult, give oxygen. Get medical attention.**
- **Liquid helium can cause severe frostbite to exposed body parts. DO NOT touch frosted pipes or valves. For frostbite, consult a physician immediately. If a physician is unavailable, warm the affected parts with water that is near body temperature.**

Two essential safety aspects of handling LHe are adequate ventilation and eye and skin protection. Although helium and nitrogen gases are non-toxic, they are dangerous because they replace air in a normal breathing atmosphere. Liquid helium is an even greater threat because a small amount of liquid evaporates to create a large amount of gas. Store and operate cryogenic dewars in open, well-ventilated areas.

When transferring LHe and LN₂, protect eyes and skin from accidental contact with liquid or the cold gas issuing from it. Protect eyes with full face shield or chemical splash goggles; safety glasses (even with side shields) are inadequate. Always wear special cryogenic gloves (Tempshield CryoGloves® or equivalent) when handling anything that is, or may have been, in contact with the liquid or cold gas, or with cold pipes or equipment. Wear long sleeve shirts and cuffless trousers long enough to prevent liquid from entering shoes.

1.2.3 Recommended First Aid

Post an appropriate Material Safety Data Sheet (MSDS) obtained from the manufacturer/distributor at every site that stores and uses LHe and LN₂. The MSDS specifies symptoms of overexposure and first aid.

If a person exhibits symptoms of asphyxia such as headache, drowsiness, dizziness, excitation, excessive salivation, vomiting, or unconsciousness, remove to fresh air. If breathing is difficult, give oxygen. If breathing stops, give artificial respiration. Call a physician immediately.

If exposure to cryogenic liquids or cold gases occurs, restore tissue to normal body temperature (98.6 °F) by bathing it in warm water not exceeding 105 °F (40 °C). DO NOT rub the frozen part, either before or after rewarming. Protect the injured tissue from further damage and infection and call a physician immediately. Flush exposed eyes thoroughly with warm water for at least 15 minutes. In case of massive exposure, remove clothing while showering with warm water. The patient should not drink alcohol or smoke. Keep warm and rest. Call a physician immediately.

1.3 ELECTROSTATIC DISCHARGE

Electrostatic Discharge (ESD) may damage electronic parts, assemblies, and equipment. ESD is a transfer of electrostatic charge between bodies at different electrostatic potentials caused by direct contact or induced by an electrostatic field. The low-energy source that most commonly destroys Electrostatic Discharge Sensitive (ESDS) devices is the human body, which generates and retains static electricity. Simply walking across a carpet in low humidity may generate up to 35,000 volts of static electricity.

Current technology trends toward greater complexity, increased packaging density, and thinner dielectrics between active elements, which results in electronic devices with even more ESD sensitivity. Some electronic parts are more ESDS than others. ESD levels of only a few hundred volts may damage electronic components such as semiconductors, thick and thin film resistors, and piezoelectric crystals during testing, handling, repair, or assembly. Discharge voltages below 4000 volts cannot be seen, felt, or heard.

1.3.1 Identifying ESDS Components

Below are some industry symbols used to label components as ESDS:



1.3.2 Handling ESDS Components

Observe all precautions necessary to prevent damage to ESDS components before installation. Bring the device and everything that contacts it to ground potential by providing a conductive surface and discharge paths. At a minimum, observe these precautions:

1. De-energize or disconnect all power and signal sources and loads used with unit.
2. Place unit on a grounded conductive work surface.
3. Ground technician through a conductive wrist strap (or other device) using 1 M Ω series resistor to protect operator.
4. Ground any tools, such as soldering equipment, that will contact unit. Contact with operator's hands provides a sufficient ground for tools that are otherwise electrically isolated.
5. Place ESDS devices and assemblies removed from a unit on a conductive work surface or in a conductive container. An operator inserting or removing a device or assembly from a container must maintain contact with a conductive portion of the container. Use only plastic bags approved for storage of ESD material.
6. Do not handle ESDS devices unnecessarily or remove from the packages until actually used or tested.

1.4 SAFETY SUMMARY

Observe these general safety precautions during all phases of instrument operation, service, and repair. Failure to comply with these precautions or with specific warnings elsewhere in this manual violates safety standards of design, manufacture, and intended instrument use. Lake Shore Cryotronics, Inc. assumes no liability for Customer failure to comply with these requirements.

Ground The Instrument

To minimize shock hazard, connect instrument chassis and cabinet to an electrical ground. The instrument comes with a 3-conductor AC power cable. Plug it into an approved three-contact electrical outlet or use a three-contact adapter with the green ground wire firmly secured to an electrical ground (safety ground) at the power outlet. The power cable jack and mating plug meet Underwriters Laboratories (UL) and International Electrotechnical Commission (IEC) safety standards.

Do Not Operate In An Explosive Atmosphere

Do not operate the instrument in the presence of flammable gases or fumes. Operation of any electrical instrument in such an environment constitutes a definite safety hazard.

Keep Away From Live Circuits

Operating personnel must not remove instrument covers. Refer component replacement and internal adjustments to qualified maintenance personnel. Do not replace components with power cable connected. To avoid injuries, always disconnect power and discharge circuits before touching them.

Do Not Substitute Parts Or Modify Instrument

Do not install substitute parts or perform any unauthorized modification to the instrument. Return the instrument to an authorized Lake Shore Cryotronics, Inc. representative for service and repair to ensure that safety features are maintained.

1.5 SAFETY SYMBOLS



Direct current (power line).



Alternating current (power line).



Alternating or direct current (power line).



Three-phase alternating current (power line).



Earth (ground) terminal.



Protective conductor terminal.



Frame or chassis terminal.



On (supply).



Off (supply).



Equipment protected throughout by double insulation or reinforced insulation (equivalent to Class II of IEC 536 - see Annex H).



Caution: High voltages; danger of electric shock.
Background color: Yellow; Symbol & outline: Black.



Caution or Warning - See instrument documentation. Background color: Yellow; Symbol and outline: Black.



Fuse.

CHAPTER 2

INSTALLATION

2.0 GENERAL

This chapter covers Inspection and Unpacking in Paragraph 2.1, Repackaging for Shipment in Paragraph 2.2, Power and Ground Requirements in Paragraph 2.3, and Sensor Installation Recommendations in Paragraph 2.4.

2.1 INSPECTION AND UNPACKING

Inspect shipping containers for external damage. Make all claims for damage (apparent or concealed) or partial loss of shipment in writing to Lake Shore within five (5) days from receipt of goods. If damage or loss is apparent, please notify the shipping agent immediately.

Open the shipping containers. Use the packing list included with the system to verify receipt of the instrument, sensor, accessories, and manual. Inspect for damage. Inventory all components supplied before discarding any shipping materials. If there is freight damage to the instrument, file proper claims promptly with the carrier and insurance company and notify Lake Shore. Notify Lake Shore immediately of any missing parts. Lake Shore cannot be responsible for any missing parts unless notified within 60 days of shipment. See the standard Lake Shore Warranty on the A Page (immediately behind the title page).

2.2 REPACKAGING FOR SHIPMENT

To return the Model 102 or accessories for repair or replacement, obtain a Return Goods Authorization (RGA) number from Technical Service in the United States, or from the authorized sales/service representative from which the product was purchased. Instruments may not be accepted without a RGA number. When returning an instrument for service, Lake Shore must have the following information before attempting any repair.

1. Instrument model and serial number.
2. User name, company, address, and phone number.
3. Malfunction symptoms.
4. Description of system.
5. Returned Goods Authorization (RGA) number.

Repack the system in its original container (if available). Affix shipping labels and FRAGILE warnings. Write RGA number on the outside of the container or on the packing slip. If not available, consult Lake Shore for shipping and packing instructions.

2.3 POWER AND GROUND REQUIREMENTS

The Model 102 requires a power source of 90 to 125 or 200 to 250 VAC, 50 or 60 Hz, single phase. The proper wall mounted AC power adapter ships with the Model 102. Connect to front panel power plug.

WARNING: To prevent electrical fire or shock hazards, do not expose this instrument to rain or excess moisture.

NOTE: Do not attach the shield to earth ground at the sensor end. It may introduce noise at the measurement end.

Shield sensor cables whenever possible. Attach shields to the connector shield pin.

2.4 SENSOR INSTALLATION RECOMMENDATIONS

Although the Model 102 acts as a current source for any application, it can provide the 10 μ A excitation current for Lake Shore 400-Series, 500-Series, and TG-120 Diode Sensors. See the Lake Shore Product Catalog for installation details and sensor specifications. Call Lake Shore for copies of application notes or sensor installation questions. Although a sensor is not provided with the Model 102, below are general recommendations on sensor installation:

1. Do not ground the sensor.
2. Shield leads and connect shield wire to SHIELD on screw terminal connector only. Do not connect shield at other end of cable.
3. Keep leads as short as possible.
4. Use twisted-pair wire. Use Lake Shore Duo-Twist™ wire (or equivalent) for two-wire, or Quad-Twist™ wire (or equivalent) for four-wire applications.
5. Thermally anchor lead wires.

2.4.1 Connecting Leads To The Sensor

Excessive heat flow through connecting leads to any temperature sensor may differ the temperature between the active sensing element and the sample to which the sensor mounts. This reflects as a real temperature offset between what is measured and the true sample temperature.

Eliminate such temperature errors with proper selection and installation of connecting leads.

To minimize heat flow through the leads, select leads of small diameter and low thermal conductivity. Phosphor-bronze or Manganin wire is commonly used in sizes 32 or 36 AWG. These wires have a fairly low thermal conductivity, yet electrical resistance is not large enough to create measurement problems.

Thermally anchor lead wires at several temperatures between room temperature and cryogenic temperatures to guarantee no heat conduction through the leads to the sensor.

2.4.2 Sensor Mounting

Before installing a diode sensor, identify which lead is the anode and which is the cathode. When viewed with the base down and the leads towards the observer, the anode is on the right and the cathode is on the left. The Lake Shore DT-470-SD silicon diode sensor lead configuration is shown to the right. For other sensors, read accompanying literature or consult the manufacturer to positively identify sensor leads. Lead identification should remain clear even after sensor installation. Record the sensor serial number and location.

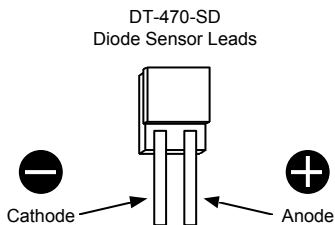

On the DT-470-SD, the base is the largest flat surface. It is sapphire with gold metalization over a nickel buffer layer. The base is electrically isolated from the sensing element and leads; make all thermal contact to the sensor through the base. A thin braze joint around the sides of the SD package electrically connect to the sensing element. Avoid contact to the sides with any electrically conductive material.

When installing the sensor, make sure there are no electrical shorts or current leakage paths between the leads or between the leads and ground. If IMI-7031 varnish or epoxy is used, it may soften varnish-type lead insulations so that high resistance shunts appear between wires if *sufficient time for curing is not allowed*.

Slide Teflon[®] spaghetti tubing over bare leads when the possibility of shorting exists. Avoid putting stress on the device leads and allow for thermal contractions that occur during cooling which could fracture a solder joint or lead if installed under tension at room temperature.

For temporary mounting in cold temperature applications, apply a thin layer of Apiezon[®] N Grease between the sensor and sample to enhance thermal contact under slight pressure. The preferred method for mounting the DT-470-SD sensor is the Lake Shore CO Adapter.

CAUTION: Lake Shore will not warranty replace any device damaged by user-designed clamps or solder mounting.

For semi-permanent mountings, use Stycast epoxy instead of Apiezon[®] N Grease. **NOTE:** Do not apply Stycast epoxy over the DT-470-SD package, sensor stress may shift the readings. In all cases, periodically inspect the sensor mounting to verify good thermal contact to the mounting surface is maintained.

2.4.3 Measurement Errors Due To AC Noise

Poorly shielded leads or improperly grounded measurement systems can introduce AC noise into the sensor leads. In diode sensors, the AC noise shifts the DC voltage measurement due to the diode non-linear current/voltage characteristics. When this occurs, measured DC voltage is too low and the corresponding temperature reading is high. The measurement error can approach several tenths of a kelvin. To determine if this problem exists, perform either procedure below.

1. Place a capacitor across the diode to shunt induced AC currents. Capacitor size depends on the noise frequency. If noise is related to power line frequency, use a 10 μF capacitor. If AC-coupled digital noise is suspected (digital circuits or interfaces), use a 0.1 to 1 μF capacitor. In either case, if measured DC voltage increases, there is induced noise in the measurement system.
2. Measure AC voltage across the diode with an AC voltmeter or oscilloscope. Most voltmeters do not have the frequency response to measure noise associated with digital circuits or interfaces (which operate in the MHz range). For a thorough discussion of this potential problem, and the magnitude of error which may result, request the paper "Measurement System-Induced Errors In Diode Thermometry," J.K. Krause and B.C. Dodrill, Rev. Sci. Instr. 57 (4), 661, April, 1986 from Lake Shore.

To greatly reduce potential AC noise, connect twisted leads (pairs) between the measurement instruments and the diode sensors. Use 32 or 36 AWG Lake Shore Duo-Twist™ Cryogenic Wire, which features phosphor bronze wire twisted at 3.2 twists per centimeter (8 twists per inch). See the Lake Shore Product Catalog or contact Lake Shore for further information.

CHAPTER 3

OPERATION

3.0 GENERAL

This chapter covers Front Panel Features and Functions in Paragraph 3.1 and Operational Notes in Paragraph 3.2.

3.1 FRONT PANEL FEATURES AND FUNCTIONS

COMPLIANCE LED. This indicator glows green when the unit operates with output within the specified compliance range (below 8 V.) The LED will not light if the current through the load is no longer at its rated level resulting in an invalid voltage reading. The LED will also go out if the unit is disconnected from power and no longer operates.

POWER Input Jack. Accepts the plug from the external wall-mounted AC transformer.

CURRENT OUTPUT Terminals. Accept standard dual banana plugs for voltmeter and sensor connection. The polarity of the terminals is marked on the front panel.

3.2 OPERATIONAL NOTES

1. Although the Model 102 is factory preset for current output of 10- μ A, it is actually "programmable" to any value between 1 μ A and 1 mA. See Paragraph 4.1.
2. To ensure accurate voltage readings across the sensor, use a voltmeter with high input impedance. This prevents the combined impedance (sensor in parallel with voltmeter) from causing a misleading measurement.
3. The Model 102 isolates AC line input noise from the current source circuitry. However, some AC noise pickup may still occur (from the test leads, AC-powered voltmeters, etc.), possibly affecting system accuracy.
4. If the unit is turned on without a load connected across the output terminals, the unit will be operating "out of compliance" and the green LED will not light. This may mislead user into thinking the unit is not functional. Add a load to correct the apparent problem.

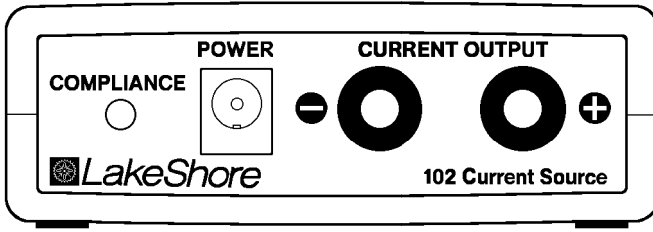

P-102-3-1.bmp

Figure 3-1. Model 102 Front Panel

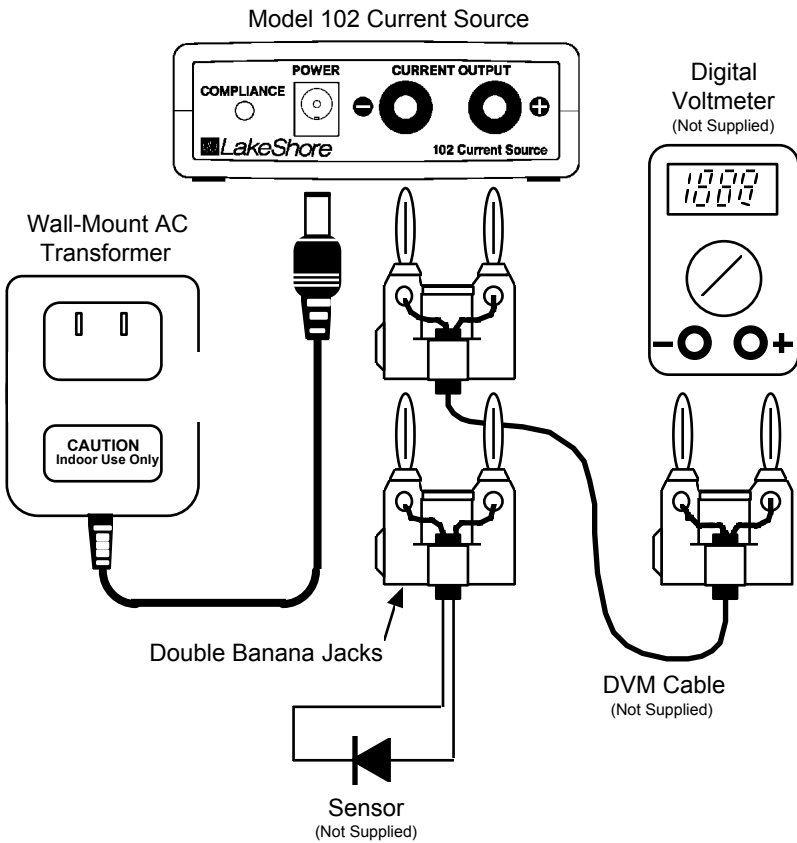

C-102-3-2.eps

Figure 3-2. Typical Model 102 Application

CHAPTER 4

SERVICE

4.0 GENERAL

This chapter covers Output Current Programming in Paragraph 4.1 and Calibration in Paragraph 4.2.

4.1 OUTPUT CURRENT REPROGRAMMING

Although the Model 102 is factory preset for a current output of 10 μA , users may set it to any value between 1 μA and 1 mA. The equation used to determine the value of the new programming resistor is:

$$I_{out} = \frac{2V}{R_{program}}$$

Use the following procedure to change the programming resistor.

1. To open the unit, remove the four rubber feet and four screws from the bottom of the unit. Gently separate the top half of the enclosure from the bottom half and front panel.
2. Remove factory-installed programming resistor R11 by clipping its leads. See Figure 4-1.
3. Install the new programming resistor by soldering it to the turrets provided on the circuit board.
4. Recalibrate the unit.
5. Replace top of enclosure, screws, and feet. Resume normal operation.

4.2 CALIBRATION

This unit has been thoroughly tested and calibrated to published specifications prior to shipment. However, periodic recalibration is recommended every six months to ensure accuracy. Recalibration is also necessary if the unit is reprogrammed to a different output current. Either of the following calibration methods are acceptable.

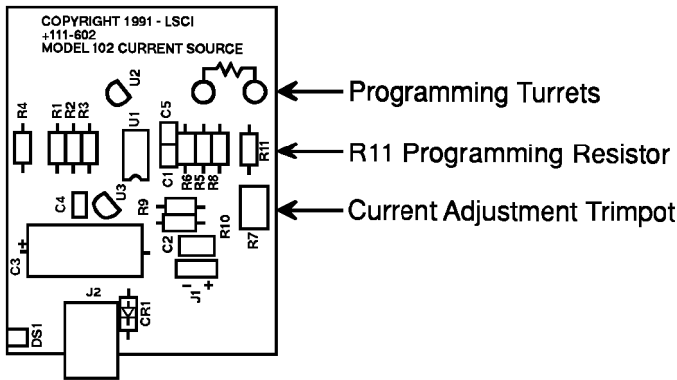

Figure 4-1. Model 102 PCB Layout

P-201-4-1.bmp

4.2.1 Current Calibration

To calibrate output current using the DC Ampere Range of a digital multimeter (DMM), use a DMM with 4-digit resolution or better and a 100 k Ω load resistor.

NOTE: If the output current has been reprogrammed to a value other than the factory preset 10 μ A, use a load resistor of the same value as the new programming resistor. Calibration accuracy is limited to DMM current measurement accuracy.

1. To open the unit, remove the four rubber feet and four screws from the bottom of the unit. Gently separate the top half of the enclosure from the bottom half and front panel.
2. Connect one end of the load resistor to the front panel **+CURRENT OUTPUT** terminal.
3. Connect the DMM HI terminal to the other end of the load resistor and the DMM LO terminal to the **-CURRENT OUTPUT** terminal.
4. Select DC Amperes on the DMM.
5. Adjust the **CURRENT ADJ** trimpot on the Model 102 circuit board until the DMM reads 10.000 μ A

NOTE: If output current has been reprogrammed to another value, adjust to that value.

6. Replace top of enclosure, screws, and feet. Resume normal operation.

4.2.2 Voltage Calibration

To calibrate output current using the DC Ampere Range of a digital multimeter (DMM), use a DMM with 4-digit resolution or better and a 100 k Ω load resistor.

NOTE: If the output current has been reprogrammed to a value other than the factory preset 10 μ A, use a load resistor of the same value as the new programming resistor. Calibration accuracy is limited to DMM current measurement accuracy.

1. To open the unit, remove the four rubber feet and four screws from the bottom of the unit. Gently separate the top half of the enclosure from the bottom half and front panel.
2. Using the DMM, measure the true resistance of the load resistor. (If the load is a precision resistor accurate to 0.01%, measuring is unnecessary.)
3. Place the load resistor between the front panel **CURRENT OUTPUT** terminals.
4. Connect the DMM HI terminal to the **+CURRENT OUTPUT** terminal, and the DMM LO terminal to the **-CURRENT OUTPUT** terminal.
5. Select DC Voltage on the DMM.
6. Adjust **CURRENT ADJ** trimpot on Model 102 circuit board until DMM reads a voltage equal to:
 $V_{load} = (\text{desired current}) \times (\text{load resistance})$
For example, if the desired current is 10 μ A and the load resistor was measured at 100.21 K, adjust the trimpot until the voltage reads 1.0021 V.
7. Replace top of enclosure, screws, and feet. Resume normal operation.

This Page Intentionally Left Blank

∞ NOTES ∞

Lake Shore

is a technology leader in the development of cryogenic temperature sensors, precision low temperature measurement and control instrumentation, and magnetic measurement and test systems. Since 1968, Lake Shore physicists, material scientists, and engineers have dedicated themselves to the development of tomorrow's technology today. Lake Shore serves a worldwide network of Customers including university and national laboratories, aerospace and other industries, as well as many of the premier companies around the world.