



# VIP2



## VK2-REC16HD

Network Video Recorder

**User Manual**



**WARNING**

TO REDUCE THE RISK OF FIRE OR ELECTRIC SHOCK, DO NOT EXPOSE THIS PRODUCT TO RAIN OR MOISTURE. DO NOT INSERT ANY METALLIC OBJECT THROUGH THE VENTILATION GRILLS OR OTHER OPENINGS ON THE EQUIPMENT.

**CAUTION**



**EXPLANATION OF GRAPHICAL SYMBOLS**



The lightning flash with arrowhead symbol, within an equilateral triangle, is intended to alert the user to the presence of uninsulated "dangerous voltage" within the product's enclosure that may be of sufficient magnitude to constitute a risk of electric shock.



The exclamation point within an equilateral triangle is intended to alert the user to the presence of important operating and maintenance (servicing) instructions in the literature accompanying the appliance.

**PRECAUTIONS**

**Safety** -----

Should any liquid or solid object fall into the cabinet, unplug the unit and have it checked by the qualified personnel before operating it any further.

Unplug the unit from the wall outlet if it is not going to be used for several days or more. To disconnect the cord, pull it out by the plug. Never pull the cord itself.

Allow adequate air circulation to prevent internal heat build-up. Do not place the unit on surfaces (rugs, blankets, etc.) or near materials (curtains, draperies) that may block the ventilation holes.

Height and vertical linearity controls located at the rear panel are for special adjustments by qualified personnel only.

**Installation** -----

Do not install the unit in an extremely hot or humid place or in a place subject to excessive dust, mechanical vibration.

The unit is not designed to be waterproof. Exposure to rain or water may damage the unit.

**Cleaning** -----

Clean the unit with a slightly damp soft cloth. Use a mild household detergent. Never use strong solvents such as thinner or benzene as they might damage the finish of the unit.

Retain the original carton and packing materials for safe transport of this unit in the future.

**Document Images** -----

**Note** – Images in this document are for graphical representation only and may vary slightly to the physical product.

## FCC COMPLIANCE STATEMENT

**INFORMATION TO THE USER:** THIS EQUIPMENT HAS BEEN TESTED AND FOUND TO COMPLY WITH THE LIMITS FOR A CLASS A DIGITAL DEVICE, PURSUANT TO PART 15 OF THE FCC RULES. THESE LIMITS ARE DESIGNED TO PROVIDE REASONABLE PROTECTION AGAINST HARMFUL INTERFERENCE WHEN THE EQUIPMENT IS OPERATED IN A COMMERCIAL ENVIRONMENT. THIS EQUIPMENT GENERATES, USES, AND CAN RADIATE RADIO FREQUENCY ENERGY AND IF NOT INSTALLED AND USED IN ACCORDANCE WITH THE INSTRUCTION MANUAL, MAY CAUSE HARMFUL INTERFERENCE TO RADIO COMMUNICATIONS.

**CAUTION:** CHANGES OR MODIFICATIONS NOT EXPRESSLY APPROVED BY THE PARTY RESPONSIBLE FOR COMPLIANCE COULD VOID THE USER'S AUTHORITY TO OPERATE THE EQUIPMENT.

THIS CLASS A DIGITAL APPARATUS COMPLIES WITH CANADIAN ICES-003.

CET APPAREIL NUMÉRIQUE DE LA CLASSE A EST CONFORME À LA NORME NMB-003 DU CANADA.

## CE COMPLIANCE STATEMENT

**WARNING:** This is a Class A product. In a domestic environment this product may cause radio interference in which case the user may be required to take adequate measures.

**CAUTION:**  
RISK OF EXPLOSION IF BATTERY IS REPLACED  
BY AN INCORRECT TYPE.  
DISPOSE OF USED BATTERIES ACCORDING  
TO THE INSTRUCTIONS

## IMPORTANT SAFETY INSTRUCTIONS

---

Read these instructions.

Keep these instructions.

Heed all warnings.

Follow all instructions.

Do not use this apparatus near water.

Clean only with dry cloth.

Do not block any ventilation openings. Install in accordance with the manufacturer's instructions.

Do not install near any heat sources such as radiators, heat registers, stoves, or other apparatus (including amplifiers) that produce heat.

Do not defeat the safety purpose of the polarized or grounding-type plug. A polarized plug has two blades with one wider than the other. A grounding type plug has two blades and a third grounding prong. The wide blade or the third prong are provided for your safety. If the provided plug does not fit into your outlet, consult an electrician for replacement of the obsolete outlet.

Protect the power cord from being walked on or pinched particularly at plugs, convenience receptacles, and the point where they exit from the apparatus.

Only use attachments/accessories specified by the manufacturer.

Use only with the cart, stand, tripod, bracket, or table specified by the manufacturer, or sold with the apparatus. When a cart is used, use caution when moving the cart/apparatus combination to avoid injury from tip-over.

Unplug this apparatus during lightning storms or when unused for long periods of time.

Refer all servicing to qualified service personnel. Servicing is required when the apparatus has been damaged in any way, such as power-supply cord or plug is damaged, liquid has been moisture, does not operate normally, or has been dropped.



**CAUTION – THESE SERVICING INSTRUCTIONS ARE FOR USE BY QUALIFIED SERVICE PERSONNEL ONLY. TO REDUCE THE RISK OF ELECTRIC SHOCK DO NOT PERFORM ANY SERVICING OTHER THAN THAT CONTAINED IN THE OPERATING INSTRUCTIONS UNLESS YOU ARE QUALIFIED TO DO SO.**

Use satisfy clause 2.5 of IEC60950-1/UL60950-1 or Certified/Listed Class 2 power source only.



# Contents

- 1. Description..... 1
  - 1.1 Components ..... 1
  - 1.2 Key Features ..... 2
  - 1.3 Overview..... 3
- 2. Installation ..... 4
  - 2.1 Connection..... 4
  - 2.2 Network Connection and IP assignment ..... 9
  - 2.3 Connecting to the Web Interface.....10
- 3. Configuration ..... 17
  - 3.1 NVR Setup.....17
    - 3.1.1 Basic Configuration .....18
    - 3.1.2 Date/Time .....19
    - 3.1.3 Internet .....20
    - 3.1.4 Intranet .....22
    - 3.1.5 Easy Install .....23
    - 3.1.6 Camera Registration .....23
    - 3.1.7 Record Storage.....24
  - 3.2 Camera Setup.....26
    - 3.2.1 Easy Install .....26
    - 3.2.2 Camera Registration .....27
- 4. Operation..... 60

4.1 Live Monitoring .....	60
4.2 Record Playback.....	63
4.3 Archive Playback .....	71
4.4 Backup Playback .....	72
5. Appendix.....	73
5.1 Troubleshooting .....	73
5.2 Comprehension about Archive and BACKUP function .....	74
5.3 Alarm Connection .....	74
5.4 Preventive Maintenance.....	75
5.5 Product Specification .....	75
5.6 Text-In Search .....	76



## 1. Description

This manual applies to the VK2 Recorder network video recorder (NVR).

The NVR supports up to 16 network cameras. The NVR can record more than 100 hours of high quality Full HD images onto its maximum capacity of hard disk drives.

The NVR is extremely straightforward to install and setup, as it detects network cameras and defines the parameters of each through a dedicated configuration wizard. You can start monitoring instantly, as the images are automatically assigned to a layout menu.

The Network Camera is fully featured for security surveillance and remote monitoring needs. It is based on an embedded linux and high performance, and makes it available on the network as real-time, full frame rate Motion JPEG and H.264 (or MPEG-4) video streams.

The alarm input and alarm output can be used to connect various third party devices, such as, door sensors and alarm bells.

### 1.1 Components

The system comes with the following components:

- Network Video Recorder unit
- Power Cord
- SATA Hard Disk Drive (Size based on Model)
- Rack-mount Kit
- Installation CD including VK2 Client Software and User Manual
- Installation Guide

**Note:** Check your package to make sure that you received the complete system, including all components shown above.

## 1.2 Key Features

The NVR provides recording capabilities up to 16 camera inputs. It provides exceptional picture quality in both live and playback modes, and offers the following features:

- Up to 16 network cameras can be connected and recorded.
- H.264, MPEG-4 and JPEG multi format.
- Quick setup by automatic camera detection and simple setup wizard without the use of PC.
- Supports HD network camera input.
- Continuous Recording with the overwrite Mode.
- Multiple Recording Mode. (Schedule, Pre-Event, Text-In and Event Recording)
- Multiple Search Engines. (Date/Time, Calendar, Event, Text-In, Bookmark)
- Daylight savings time change function.
- Alarm handling with history log and Pre-alarm recording.
- Text Input for POS.
- Network Time Synchronization.
- Self-diagnostics with automatic notification including hard disk drive S.M.A.R.T. protocol
- Live or Recorded Video Access via Ethernet.
- Built-in web client. (Live, Search & Playback)
- User authentication, 3 user levels and User level – Camera partitioning setup for user management of up to 32 user registrations
- Built-in network interface (10Base-T / 100Base-TX / 1000Base-T) for recording and client access.
- IP routing function for direct camera setup via client access.
- Up to 4 HDDs can be installed (8.89 cm (3.5 inch) Serial ATA HDD)
- Four USB 2.0 Ports
- Supports Vista VK2 IP Cameras\*

**\* Vista VK2 cameras have been integrated using the ONVIF protocol. Other third party cameras supporting the ONVIF protocol maybe compatible with the VK2 Recorder, however, Vista are unable to provide technical assistance regarding support for third party cameras.**

## 1.3 Overview

- Front View (2U Rack type)

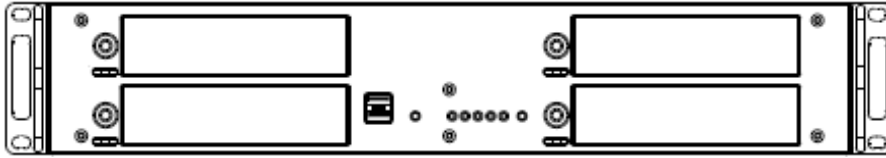

O	Function	Description
1	USB2.0 Port	Two USB ports are provided to connect external hard disk drives for data backup or USB-to-Serial text-in device.
2	RS232 Port	Connects to devices such as a text-in device.
3	VGA Port	Not used. Only for maintenance.
4	Client Ethernet Port	A network port that allows the client to connect to the product.
5	Camera Ethernet Port	A network port that the product connects to the network camera.
6	Power Cord Inlet	Used to connect the product power cable.
7	SMPS Fan	This fan cools the power supply.
8	eSATA Port	The eSATA port is provided to connect external hard disk drives for expanding storage or archiving video.
9	Alarm I/O Port	Used to connect a sensor or alarm. 1: Alarm Output 2 2: GND 3: Alarm Input 2 4: Alarm Output 1 5: GND 6: Alarm Input 1

- Rear View (2U Rack type)

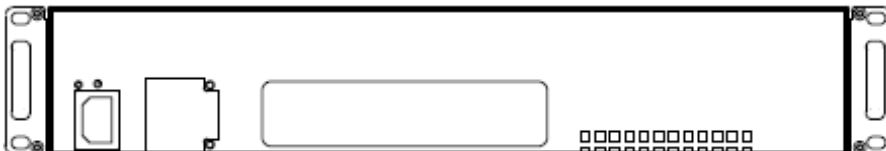

## 2. Installation

### 2.1 Connection

- Connecting to the RJ-45

Connect a standard RJ-45 cable to the network port of the network camera. Generally a cross-over cable is used for directly connection to PC, while a direct cable is used for connection to a hub.

The 2 network ports on the product back panel are for a computer and camera. The rear panel network ports can be used for devices within the same network, or in different networks as shown in the example diagram.

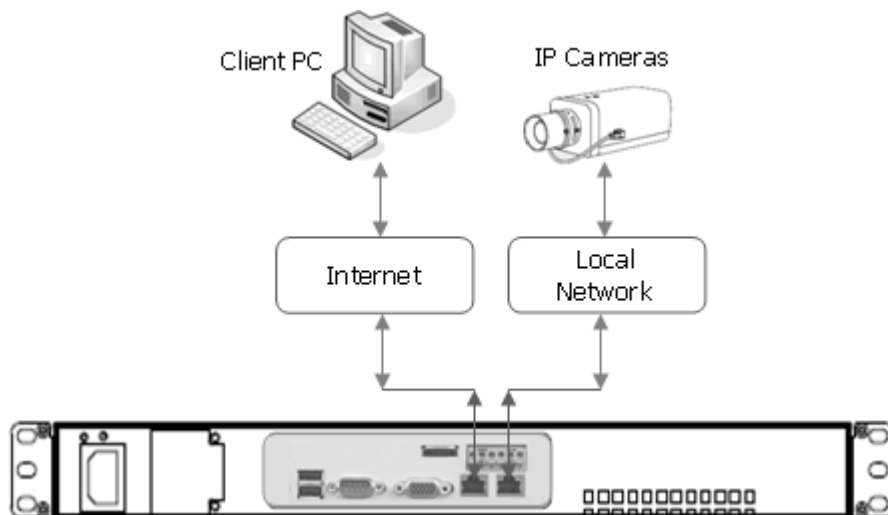

- **Connecting Alarms**

#### **Alarm Input :**

You can use external devices to signal the network camera to react on events. Mechanical or electrical switches can be wired to the Alarm Input1/2 and GND (Ground) connectors.

#### **GND(Ground) :**

Connect the ground side of the alarm input and/or alarm output to the G (Ground) connector.

#### **Alarm Output :**

The network camera can activate external devices such as buzzers or lights. Connect the device to the Alarm Output1/2 and GND(Ground) connectors.

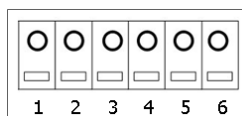

- **Connecting RS232**

An RS232 port is provided to connect a text-in device like a POS. Use a RS232 cable with a DB-9S (female) connector to connect to the NVR.

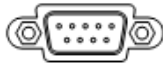

RS232

**Caution:** The VGA port is not used in the NVR.

- **Connecting USB**

The NVR supports four USB interface for connecting external storage devices; Two USB ports are located on the rear panel and other two ones are located on the front panel. You can backup some video clips of internal HDDs to the external HDDs or Memory Stick connected through USB port.

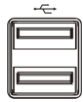

USB2.0

- **Connecting eSATA**

The NVR supports an eSATA interface for connecting external storage devices; one eSATA port is located on the rear panel. You can expand storage capacity by utilizing the internal HDDs and eSATA port.

An external eSATA HDD can be connected to the eSATA port on the rear panel. Note that an eSATA port does not supply power to the device connected to it; the external device must supply its own power.

You can also archive video data of internal HDDs to the external HDDs connected through eSATA port. When the NVR use eSATA port for archiving, it is impossible to expand storage capacity by utilizing the internal HDDs and eSATA port.



eSATA

- **Inserting SATA HDD**

Follow next steps.

1. Turn the Key Lock counterclockwise to unlock
2. Insert the SATA HDD supported to the NVR
3. Turn Key Lock clockwise to lock

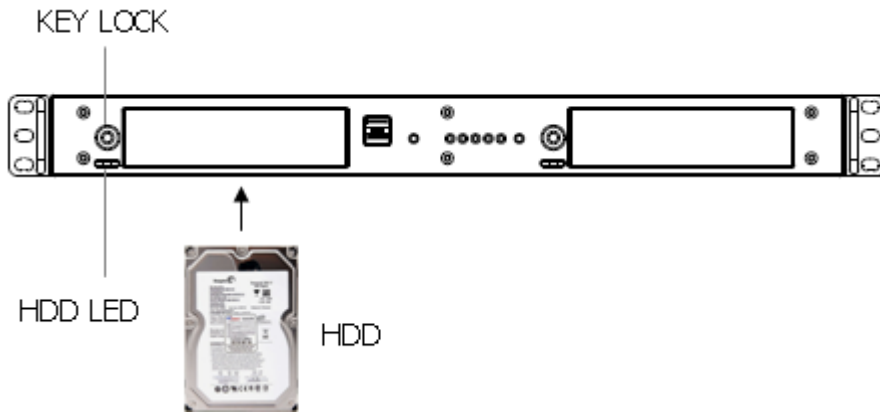

During the NVR operation, a blue HDD indicator means that internal HDD is installed and functioning normally.

**Caution:** For a proper operation, you must insert SATA HDD before turning on the power.

- **Connecting the Power Cord**

Connect the power cord to the NVR. As the power is supplied, the Power LED will start flickering, indicating stand-by mode. Pressing the POWER button will turn the power on and the Power LED will light.

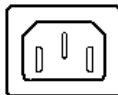

**Caution:** Power cords must be routed so that they are not likely to be walked on or pinched by furniture. Do not place the power cords under a carpet. The power plug of this equipment has a grounding pin. Use only a grounding-type power outlet. Do not destroy the plug even though you are not able to insert the plug into the outlet. Do not overload wall outlets and extension cords

- **Factory Reset**

The NVR has a Factory Reset switch to the left of the LED indicators on the front panel. This switch will only be used on the rare occasions that you want to return all the settings to the original factory settings.

To reset the unit, you will need to follow steps:

1. Press the Factory Reset button more than 5 seconds while the NVR is operating.
2. While the NVR is initializing, the alarm LED will blink.
3. After initializing, the NVR will restart.

**Caution:** When using the Factory Reset, you will lose any settings you have saved.

- **Configuration**

1. Standalone Configuration.

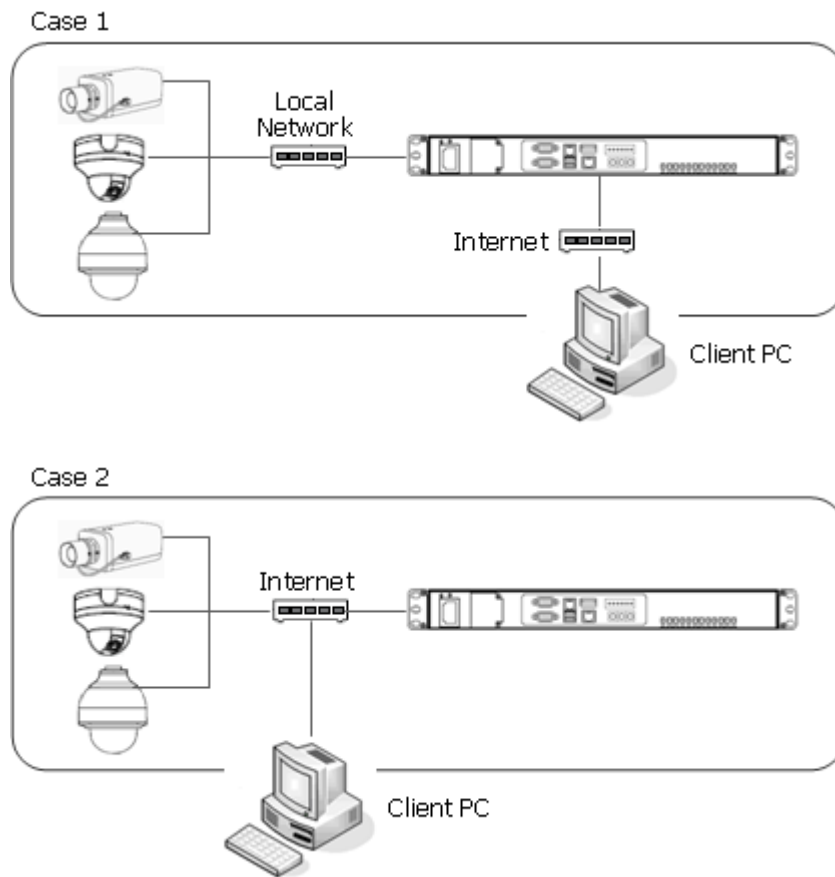

**Note:** IP cameras can be connected in the local network or in the internet, but **Client PC must be connected in the internet port**. For the best network bandwidth, it's is recommend that IP cameras and client PC are separated in the network. That is, Case 1 is recommended.

## 2. Multi-location Configuration.

Case1

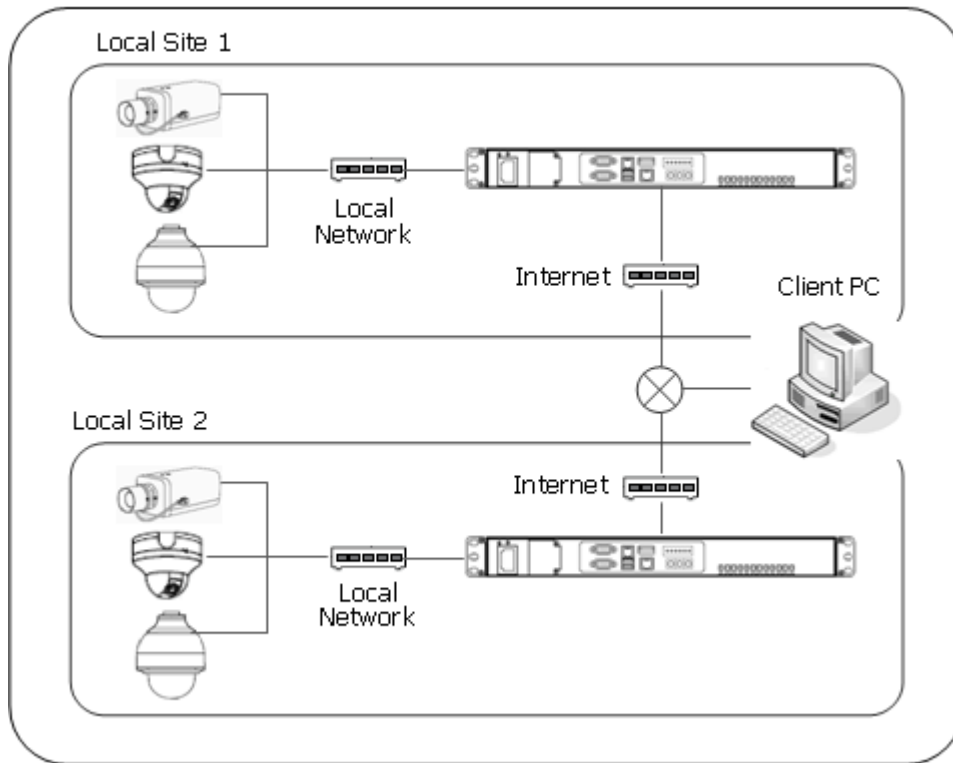

Case2

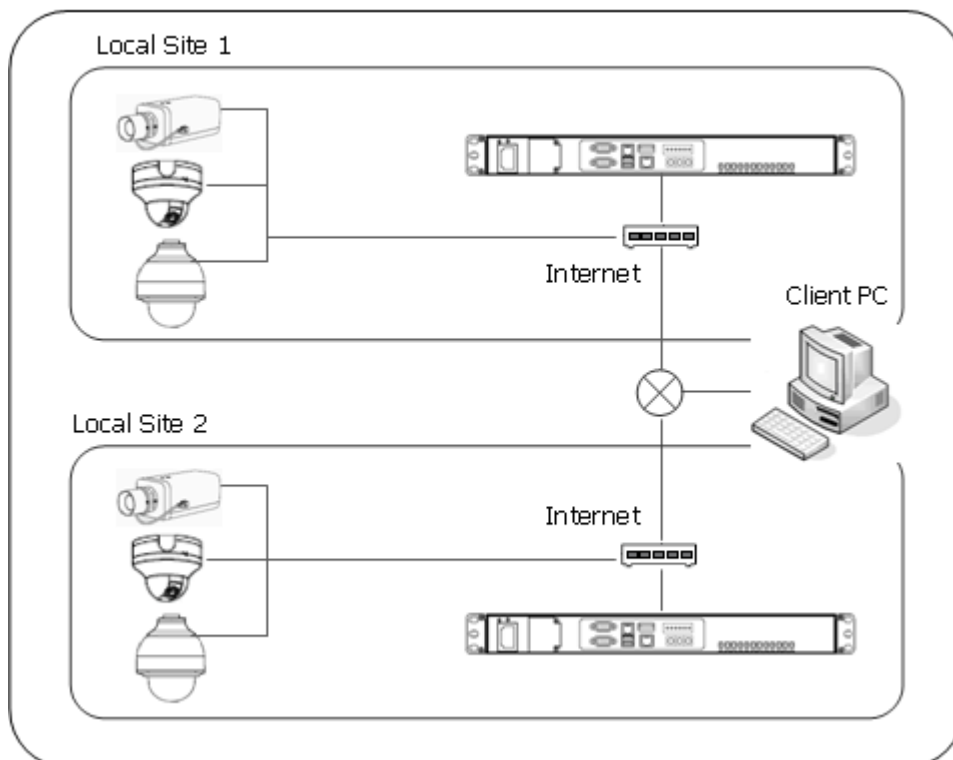



## 2.2 Network Connection and IP assignment

The Network Video Recorder supports the operation through the network. When the NVR is first connected to the network it has no IP address. So, it is necessary to allocate an IP address to the device with the “Smart Manager” utility on the CD.

1. Connect the NVR to the network and power up.
2. Start SmartManager utility ( All programs > SmartManager), the main window will be displayed, after a short while any network devices connected to the network will be displayed in the list.

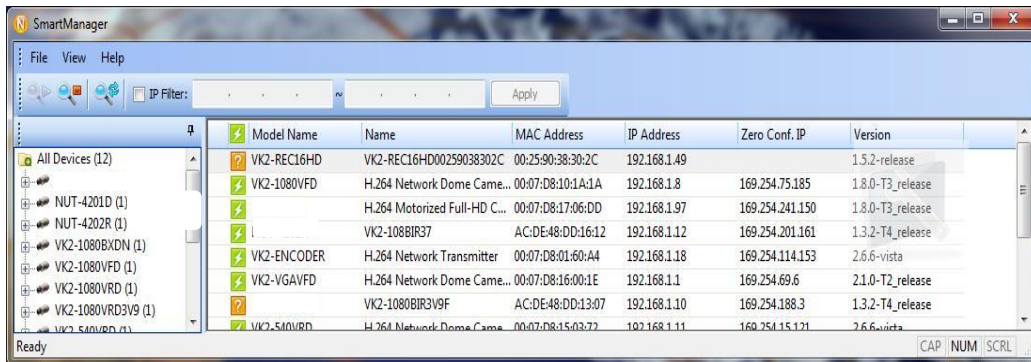

3. Select the NVR on the list and click right button of the mouse. You can see the pop-up menu as below.

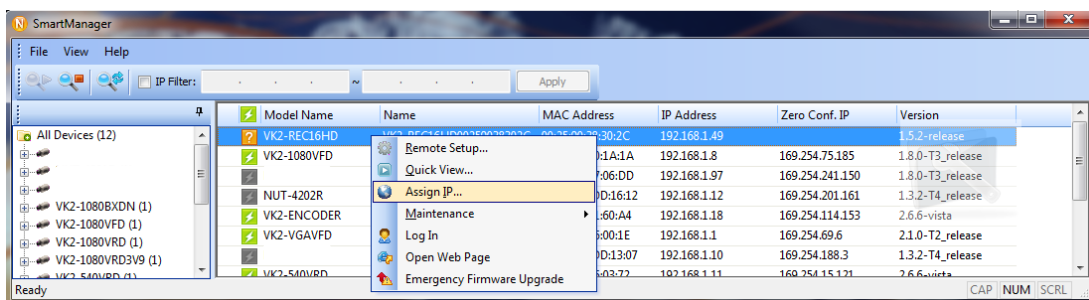

4. Select Assign IP. You can see an assign IP window. Enter the required IP address.

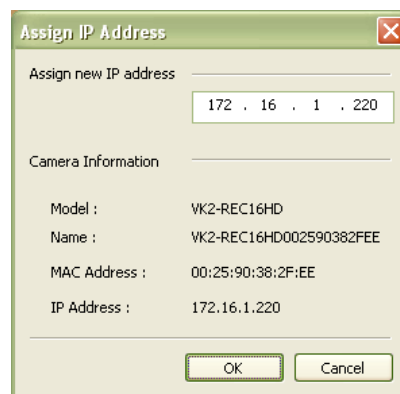

**Note:** For more information, refer to the Smart Manger User’s Manual.

## 2.3 Connecting to the Web Interface

The Network Video Recorder supports the operation through the network. When the NVR is first connected to the network, it has no IP address. So, it is necessary to allocate an IP address to the device with the “Smart Manager” utility on the CD.

**Note:** Factory Default IP address is 192.168.100.220

1. Start a browser (Internet Explorer).
2. Enter the IP address or host name of the Network Video Recorder in the Location/Address field of your browser. The VK2 Recorder installs and executes the client software automatically after installing ActiveX.
3. If the NVR has not been configured, Setup Wizard will be shown. This drastically reduces the time required for system installation. Images from cameras are connected and recorded automatically to the NVR, so that you can start monitoring and recording instantly.

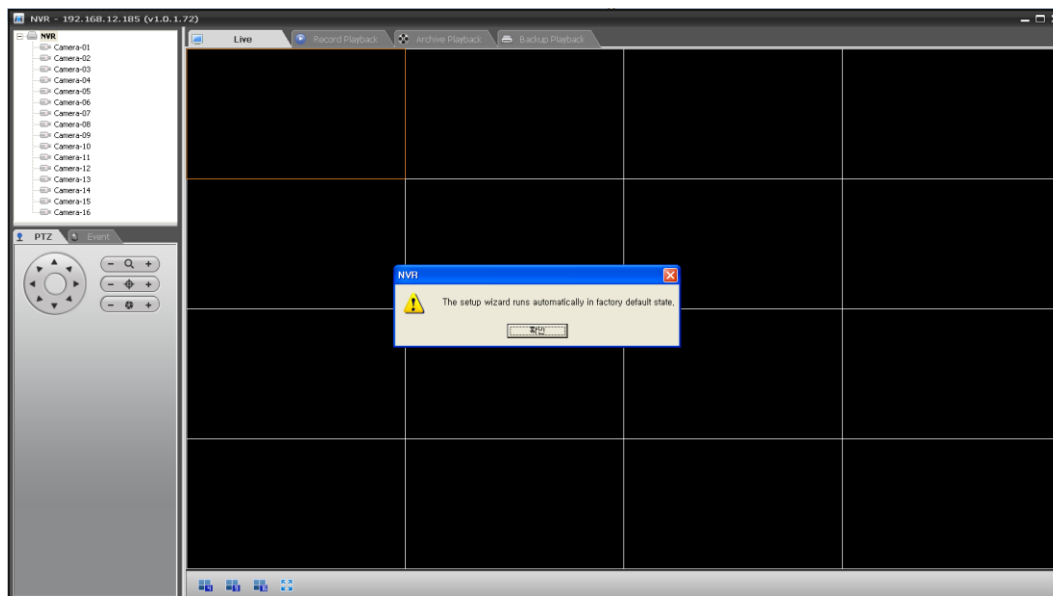

**Note:** Setup Wizard window will be shown only in factory default state.

Follow the instructions of the wizard to complete the system setup.

## [Step1]

Enter the date and time settings. You can select to synchronize the server time with an internet time server. If you enter a domain name for the NTP server, make sure you have set up a correct DNS server. Click the Next button to go to next page.

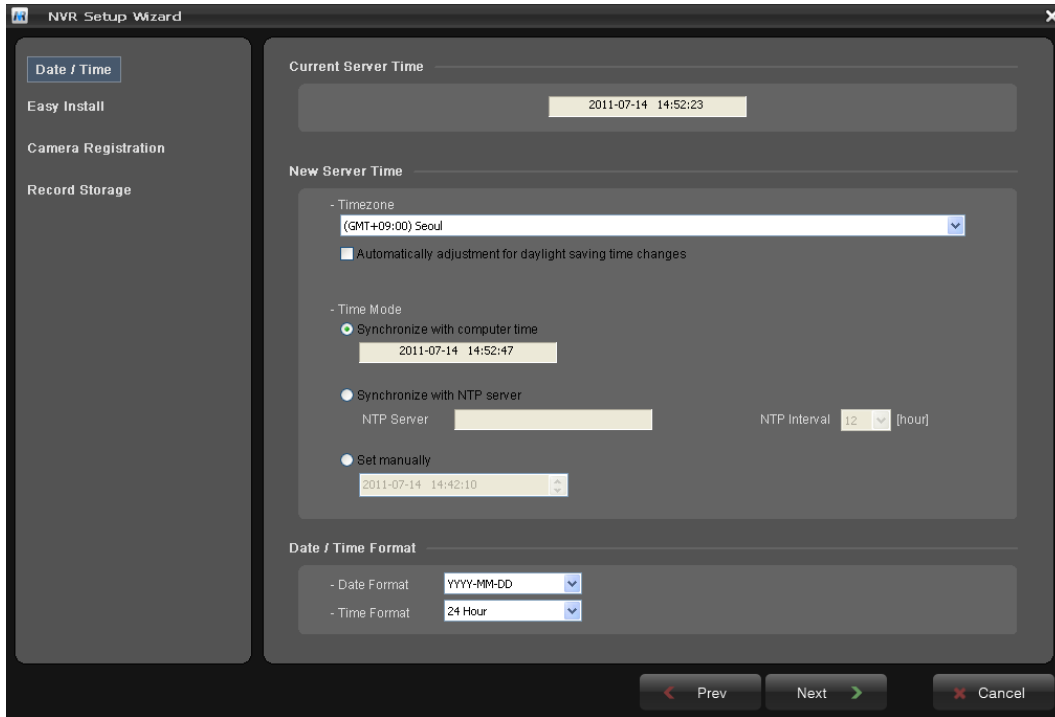

## [Step2]

Easy Installation means the NVR detects Vista VK2 Cameras based on the network and registers them automatically. Change the admin password or use the default password (admin) of cameras to be detected. If you don't want to use Easy Install function, inactivate checkbox. In case that you activated Easy Installation, you don't need to do Step3. Click the Next button to go to next page.

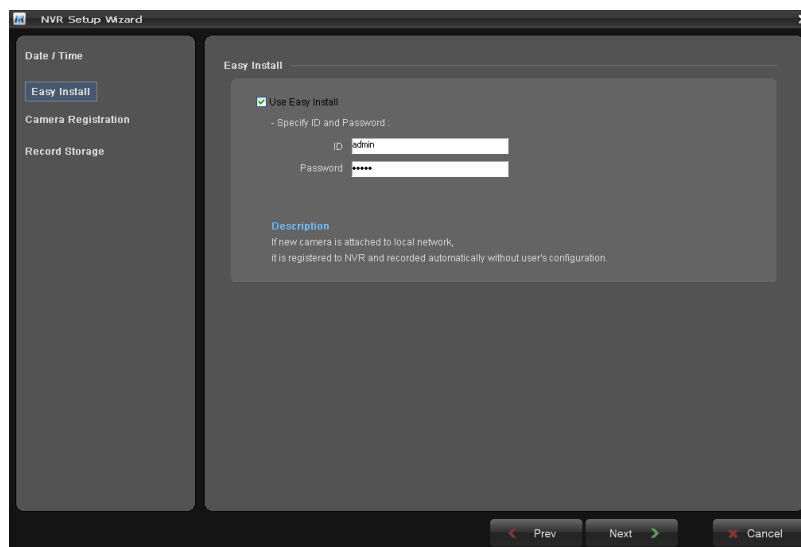

**Note:** Easy Install is inactivated in factory default.

## [Step3]

The NVR detects all of IP cameras connected in the intranet and displays in the camera list.

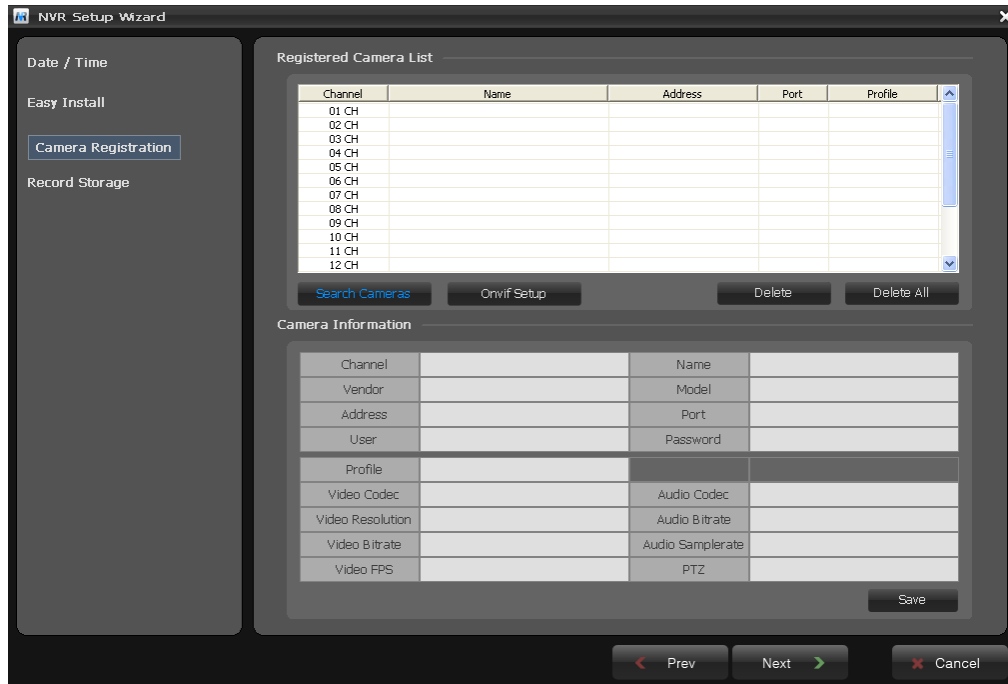

Click the Search Cameras button and the Camera Discovery window appears. Select one of three in Search Mode and click the Start Search button.

**Note:** The NVR supports only Vista VK2 Cameras.

- Search Mode:
  - Auto Search (LAN): Lists cameras in a LAN environment.
  - IP Search (Single): Allows you to enter the IP address of a device. You can search more than one device at a time by entering a range of IP addresses.
  - Domain Name Search: Allows you to enter the domain name registered on a DDNS server if the camera uses the DDNS function.

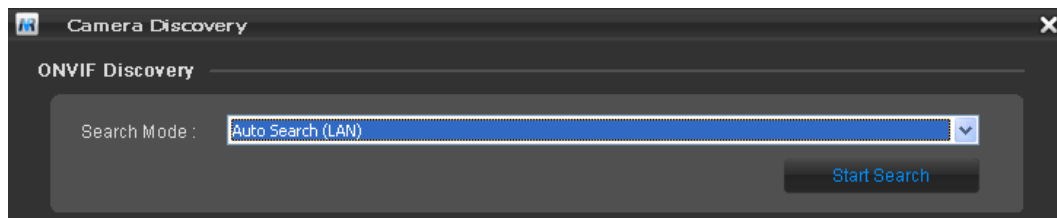

All cameras detected are displayed in the list. Display the name and IP address the selected camera. The name will be updated automatically depending on the settings of the network camera.

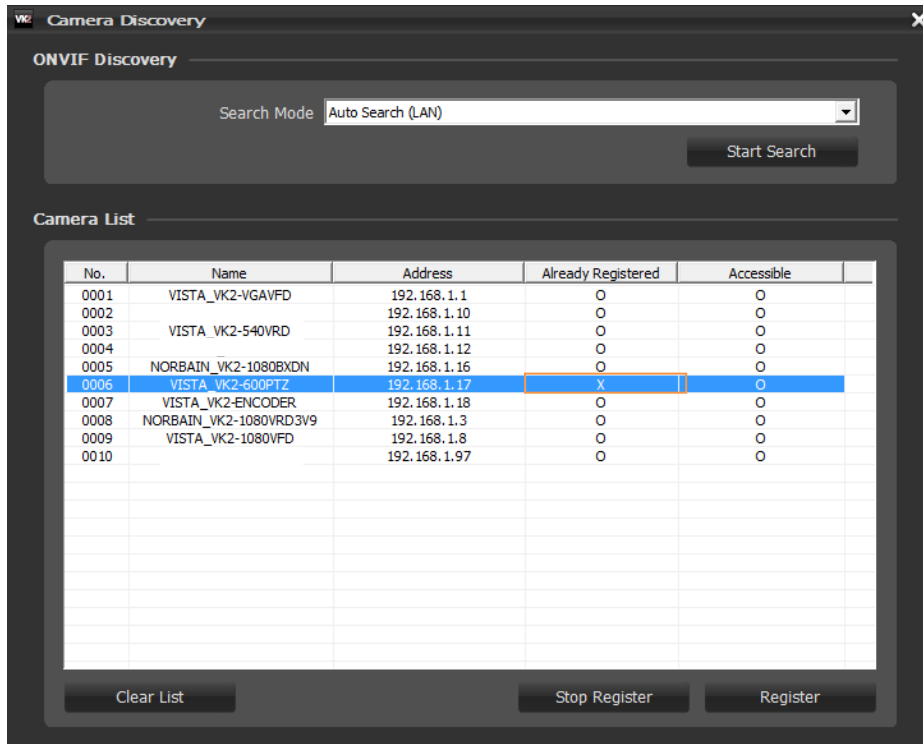

Select one or several cameras from the list and click the Register button to register. The Login window appears and inquires ID and Password.

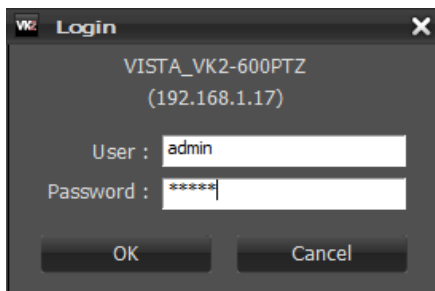

[One camera selection]

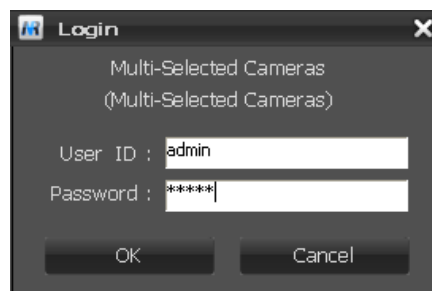

[Several camera selection]

Enter the user ID and password which you set in the camera and click the OK button in order to connect to that camera remotely. In case of selecting several cameras and registering, the username and password box will be displayed several times.

You can see the result in the Already Registered column of the ONVIF Discovery window whether succeed in registration or not.

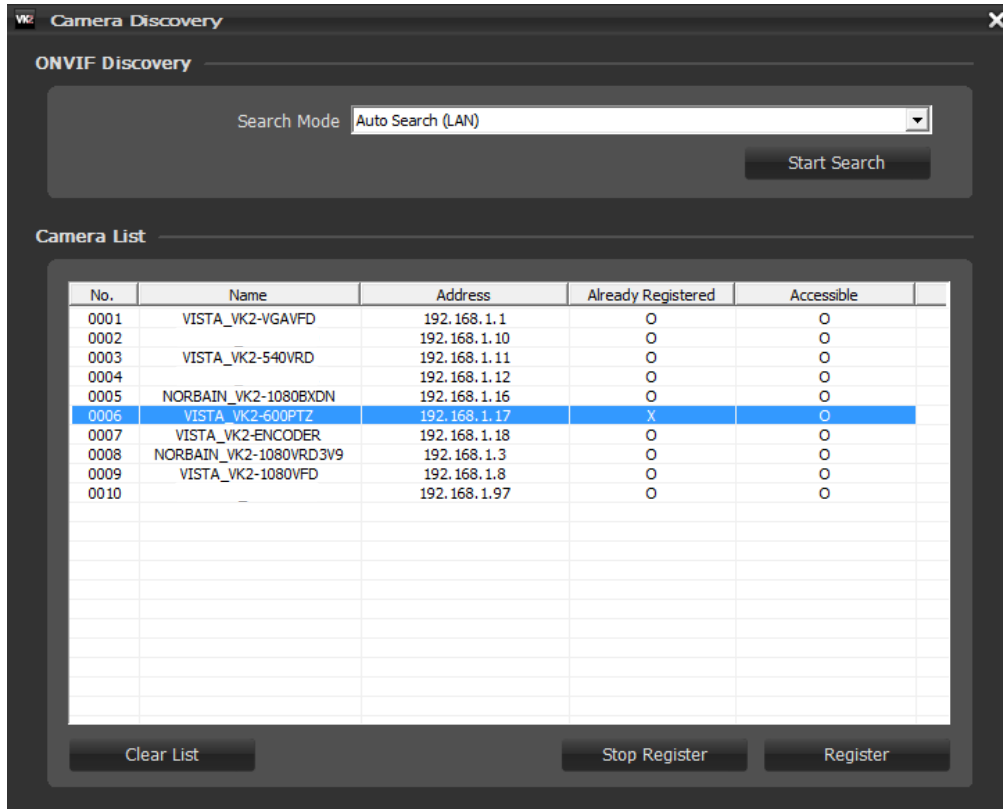

The NVR displays the registered camera list in the Camera Registration window.

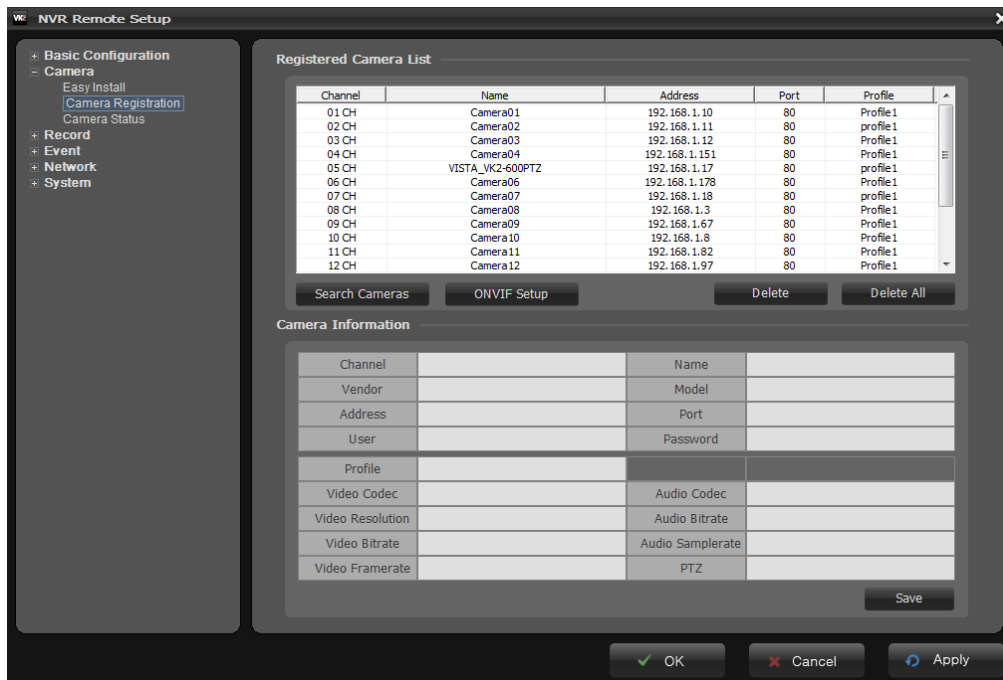

When you select a camera channel in the list, the basic information for that camera is displayed in Camera Information section. Configure camera settings you want to change. Click the Save button to save settings changed.

If you want to configure more detail information for a selected camera, click the ONVIF Setup button in the Setup Wizard window. You can configure camera settings about Profile, Video, Audio, and Network.

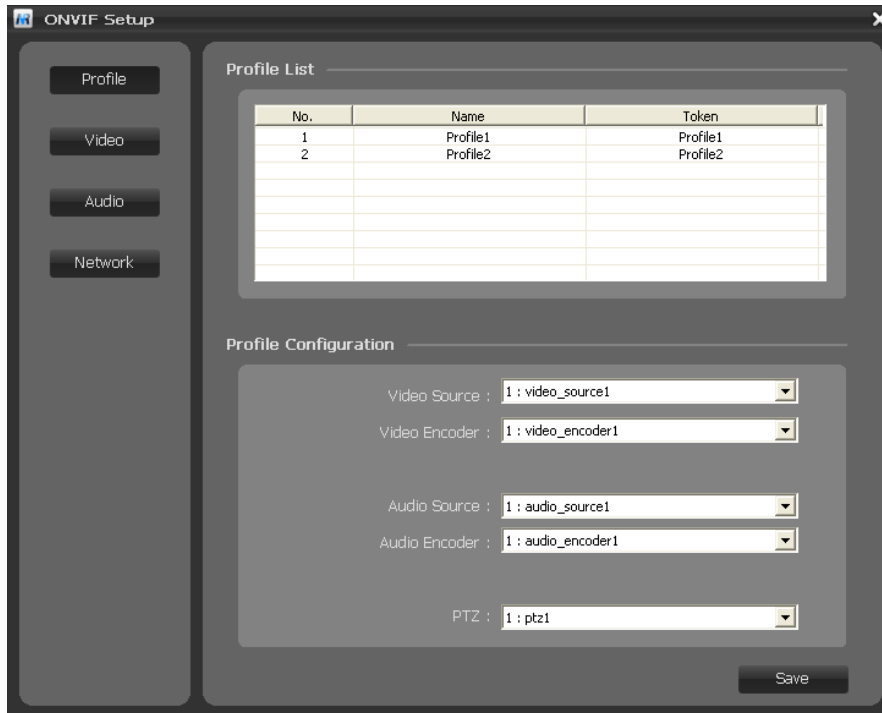

#### [Step4]

The list of available hard disk drives is displayed with the information of the hard disk drives. Select a hard disk drive from the list and click the Format button.

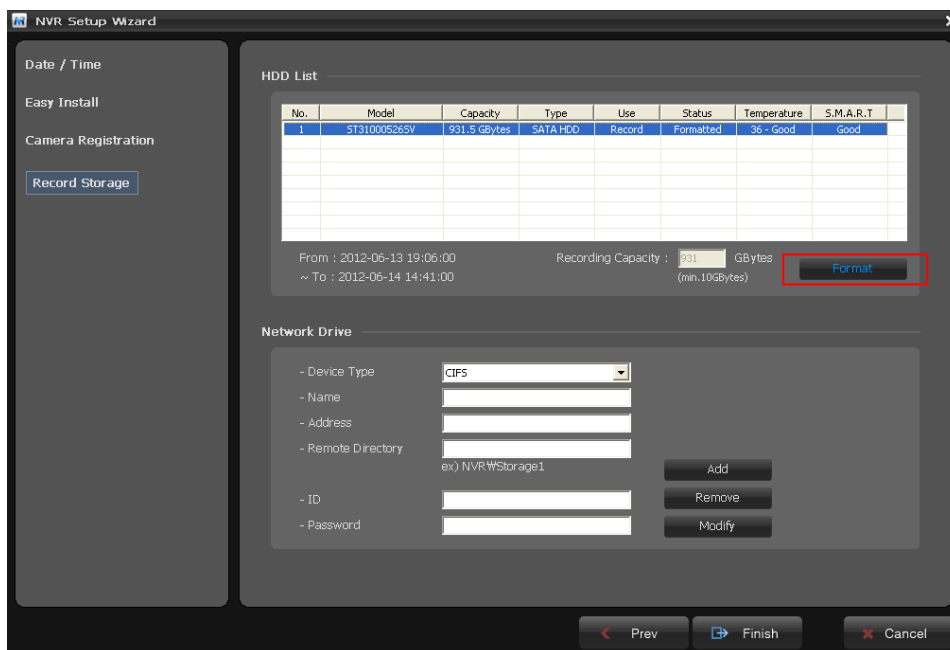

**Caution:** The HDD must be formatted before recordings will start.

When you click the Format button, the NVR asks you to set the storage to record or archive device. If the storage is formatted to archiving device, it can be used as a record storage.

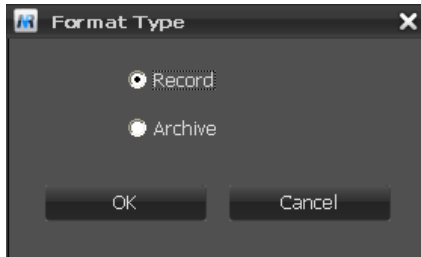

Note: Archive records a video to the recording storage and copies it to the archive storage at the same time. The external USB HDD can be set to backup device only.

Please refer to “5.2 Comprehension about Archive and BACKUP function” for more information.

The current temperature of the hard disk will be displayed in the Temperature column. The Temperature column displays Good if the temperature is below the limit and Bad if the temperature is above the limit.

If the hard disk installed in the NVR supports S.M.A.R.T. (Self-Monitoring Analysis and Reporting Technology) monitoring program, the status of the installed IDE hard disk is displayed. The current status of the Disk S.M.A.R.T. will be displayed in the S.M.A.R.T. column. The S.M.A.R.T. field displays Good if the Disk S.M.A.R.T. is good and Bad if it is bad.

The Disk Temperature and S.M.A.R.T. status is monitored in real-time.

Click the Finish button to exit Setup Wizard window. If you completed the Setup Wizard step successfully, the NVR displays a live screen and starts recording automatically.

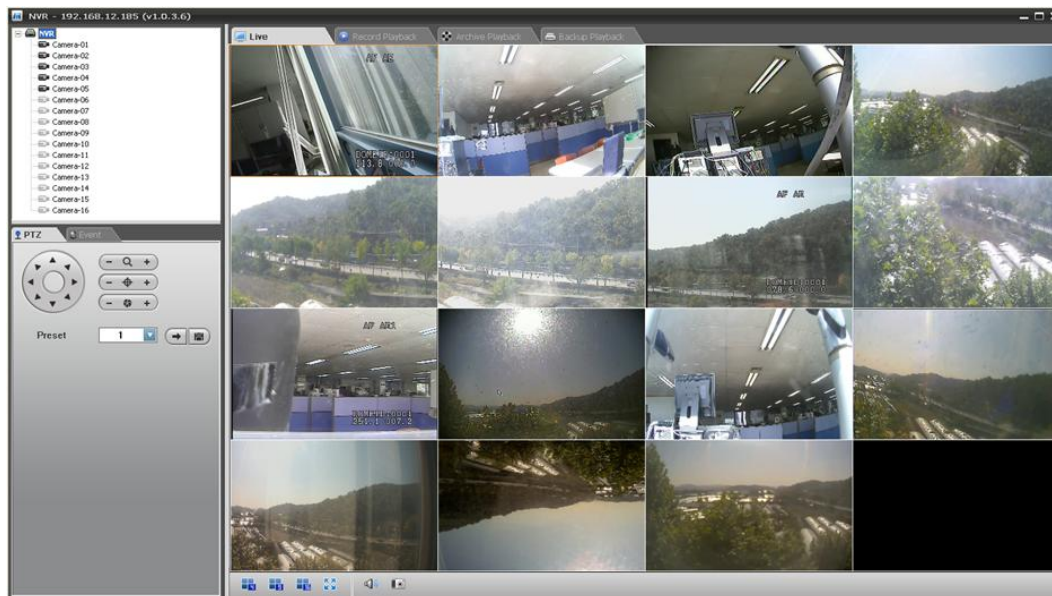

**Note:** In case that you don't use Easy Installation function, you must register and configure IP cameras manually for proper operation.



## 3. Configuration

### 3.1 NVR Setup

Select “Live” tab on the main window of the Client s/w. You can see the camera list currently registered. Select NVR or Camera in the list and right-click of mouse. The pop-up menu appears as below.

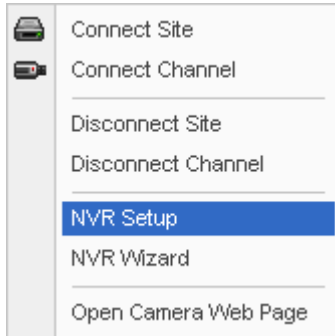

Select “NVR Setup” and the following screen appear.

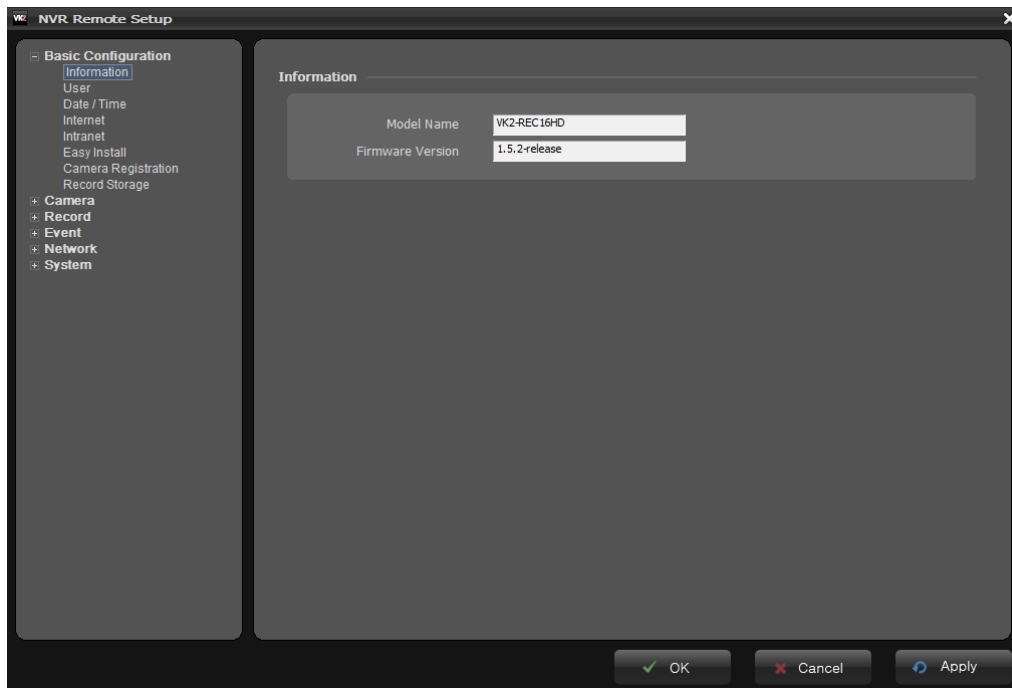

## 3.1.1 Basic Configuration

This menu offers basic settings in order to perform proper operation.

### 1) Information

You can name the Device Name for the NVR. This page is very useful when you refer device information after installation.

### 2) User

You can add and delete and users. When adding a user, you can assign authority levels to the users.

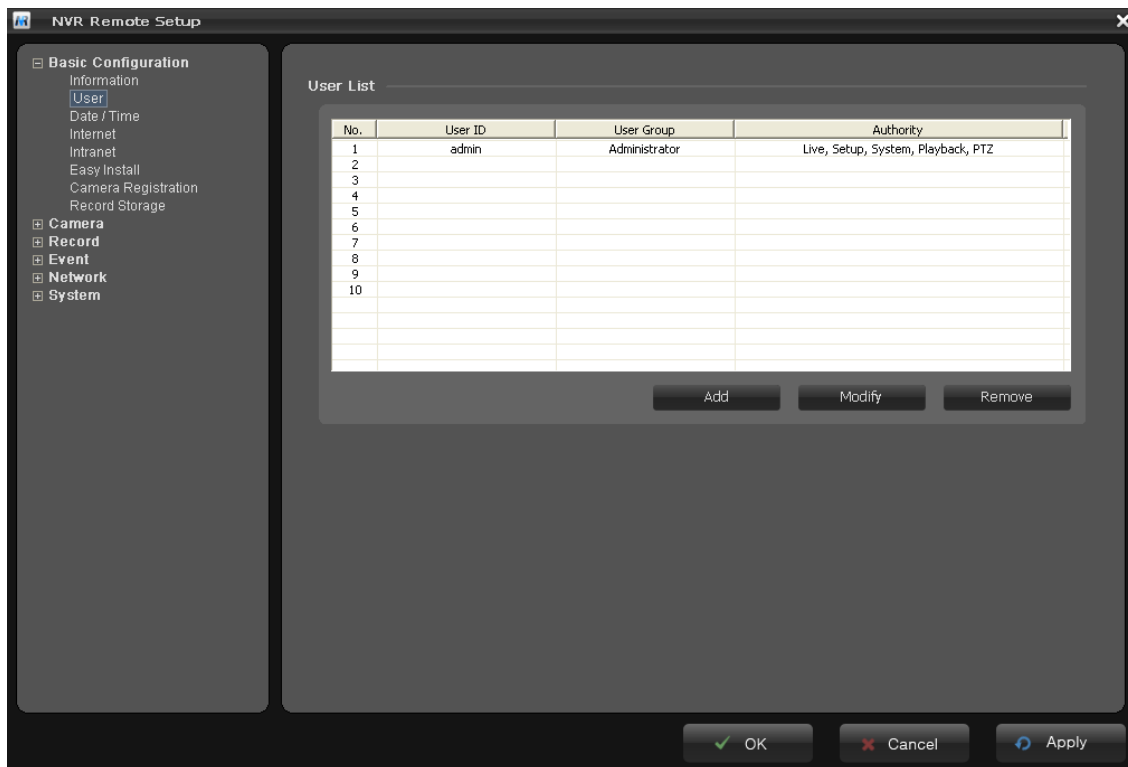

User access control is enabled by default. An administrator can set up other users, by giving these user IDs, passwords and access rights. Click the Add button to add a new user.

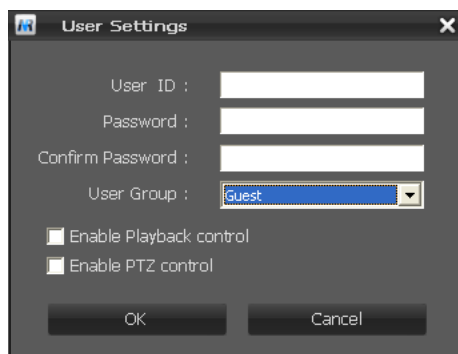

The **user list** displays the authorized users and user groups (levels):

User Group	Authority
Guest	Provides the lowest level of access, which only allows access to the Live View page.
Operator	An operator can view the Live View, Playback, create and modify events, and adjust certain other settings. Operators have no access to System Options.
Administrator	An administrator has unrestricted access to the Setup tools and can determine the registration of all other users.

- **User ID and Password**

The user ID and Password must be 1 to 15 characters in length. It supports alphabets (A-Z), numbers (0-9), and underscore(\_). It is case-insensitive and cannot contain the following characters:

“ / \ [ ] & % : ; | = , + \* ? < > ` ` ”

- **Access Control**

Assign the rights of playback, and PTZ control to the user.

**Note:** Factory default password for admin user is “admin”.

## 3.1.2 Date/Time

Set the date, time, and time zone according to your location. If the settings are incorrect, the following problems may occur:

- Incorrect time display on the video files.
- Incorrect time display on the event logs.

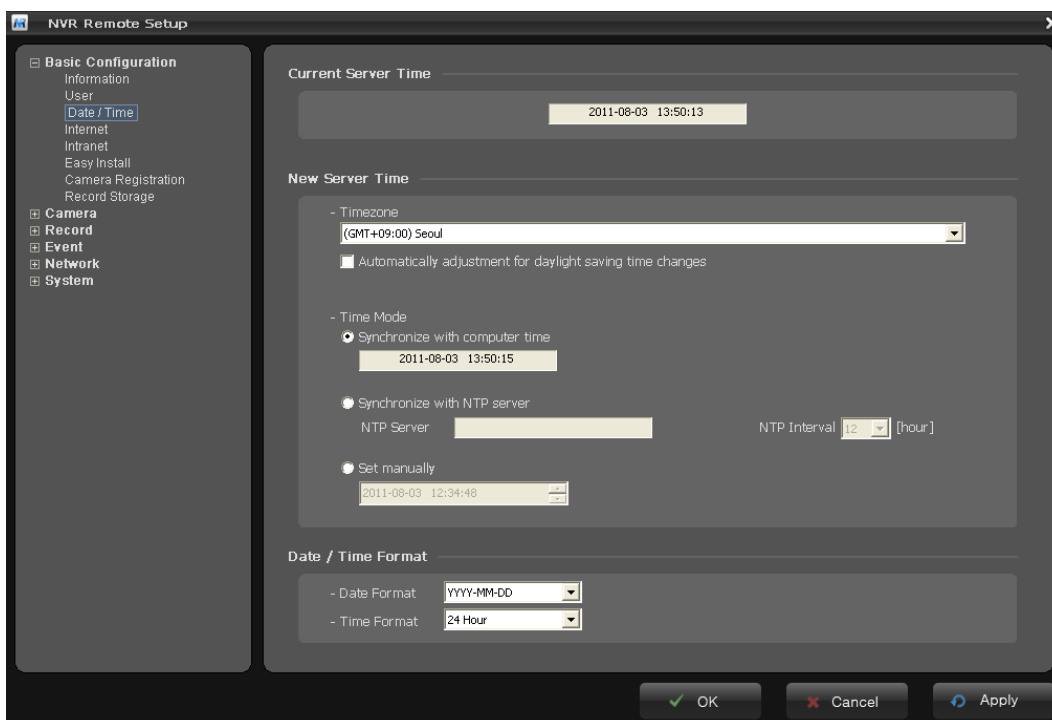

- Time Zone

Select your time zone from the drop-down list. If you want the server clock to automatically adjust for daylight savings time, select the “Automatically adjustment for daylight saving time changes”.

**Note:** The Factory default of time zone is “(GMT-05:00) EASTERN TIME (US & CANADA)”.

- Time Mode

- Synchronize with computer time:

Synchronize the date and time of the NVR automatically with your computer time.

- Synchronize with NTP server:

Synchronize the date and time of the NVR automatically with an NTP (Network Time Protocol) server. Enter the IP address or the domain name of the NTP server, for example, [time.nist.gov](http://time.nist.gov) or [time.windows.com](http://time.windows.com).

- Set manually:

This option allows you to manually set the time and date.

### 3.1.3 Internet

The NVR supports two LAN ports, so you can use one LAN port for the client monitoring through internet. To use these features, make sure both LAN ports are connected to the network.

Setting in regard to network can be executed

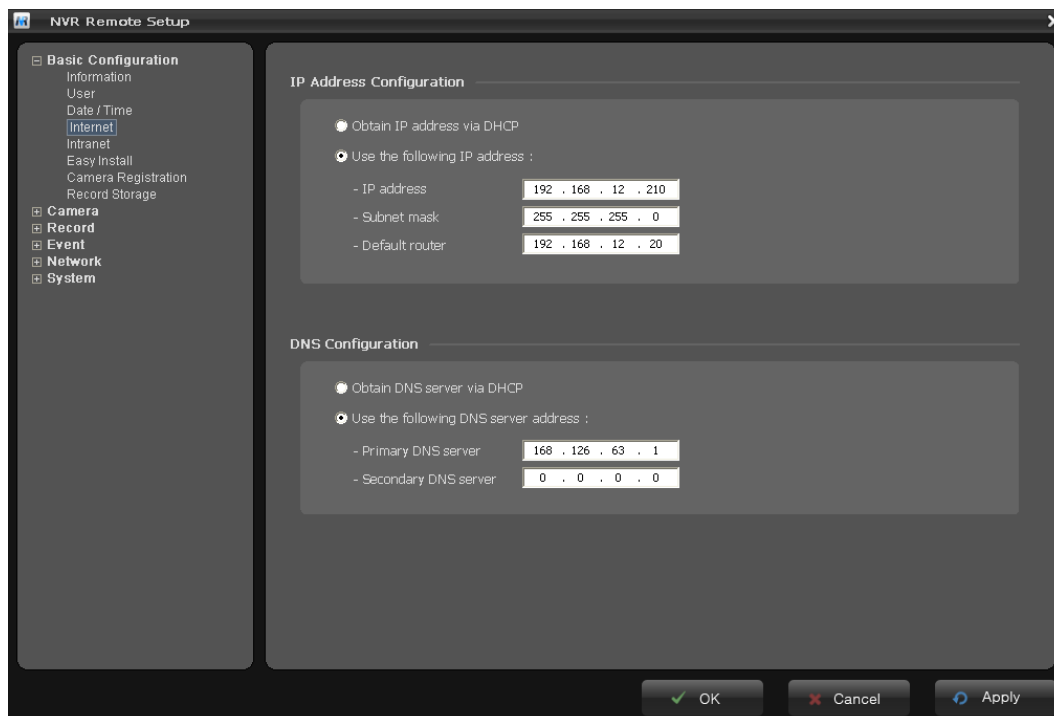

- **Obtain IP address via DHCP**

Dynamic Host Configuration Protocol (DHCP) is a protocol that lets network administrators centrally manage and automate the assignment of IP addresses on a network. DHCP is enabled by default. Although a DHCP server is mostly used to set an IP address dynamically, it is also possible to use it to set a static, known IP address for a particular MAC address.

- **Use the following IP address**

To use a static IP address for the Network Camera, check the radio button and then make the following settings:

- **IP address:**

Specify a unique IP address for your Network Camera.

- **Subnet mask:**

Specify the mask for the subnet the Network Camera is located on.

- **Default router:**

Specify the IP address of the default router (gateway) used for connecting devices attached to different networks and network segments.

- **DNS Configuration**

DNS (Domain Name Service) provides the translation of host names to IP addresses on your network.

- **Obtain DNS Server via DHCP:**

Automatically use the DNS server settings provided by the DHCP server. Click the View button to see the current settings.

- **Use the following DNS server address:**

Use to enter the desired DNS server by specifying the following:

\* **Domain name:** Enter the domain(s) to search for the host name used by the Network Camera.

Multiple domains can be separated by semicolons (;). The host name is always the first part of a Fully Qualified Domain Name, for example, myserver is the host name in the Fully Qualified Domain Name [myserver.mycompany.com](#) where mycompany.com is the Domain name.

\* DNS servers: enter the IP addresses of the primary and secondary DNS servers.

## 3.1.4 Intranet

The NVR supports two LAN ports, so you can use one LAN port for the camera connection through local network. To use these features, make sure both LAN ports are connected to the network. Setting in regard to network can be executed.

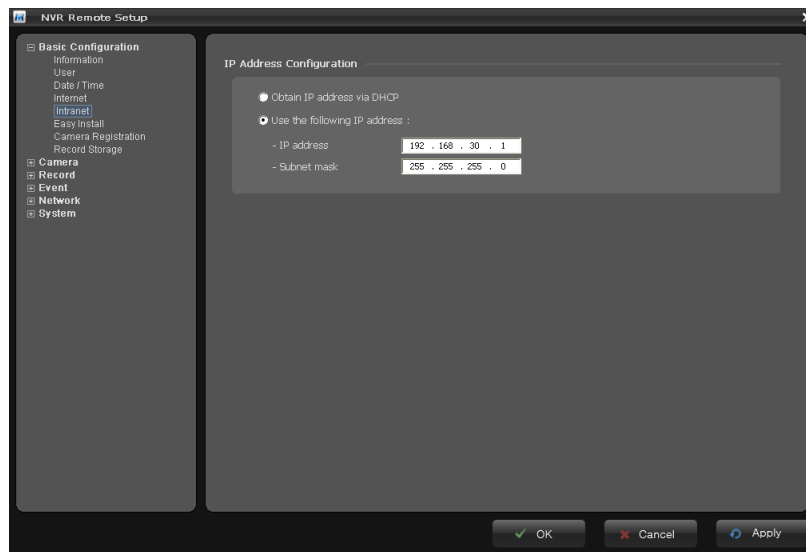

- **Obtain IP address via DHCP**

Dynamic Host Configuration Protocol (DHCP) is a protocol that lets network administrators centrally manage and automate the assignment of IP addresses on a network. DHCP is enabled by default. Although a DHCP server is mostly used to set an IP address dynamically, it is also possible to use it to set a static, known IP address for a particular MAC address.

- **Use the following IP address**

To use a static IP address for the NVR, check the radio button and then make the following settings:

- . **IP address:**

Specify a unique IP address for the NVR.

- . **Subnet mask:**

Specify the mask for the subnet the NVR is located on.

## 3.1.5 Easy Install

You can activate or inactivate the Easy Install function in this window.

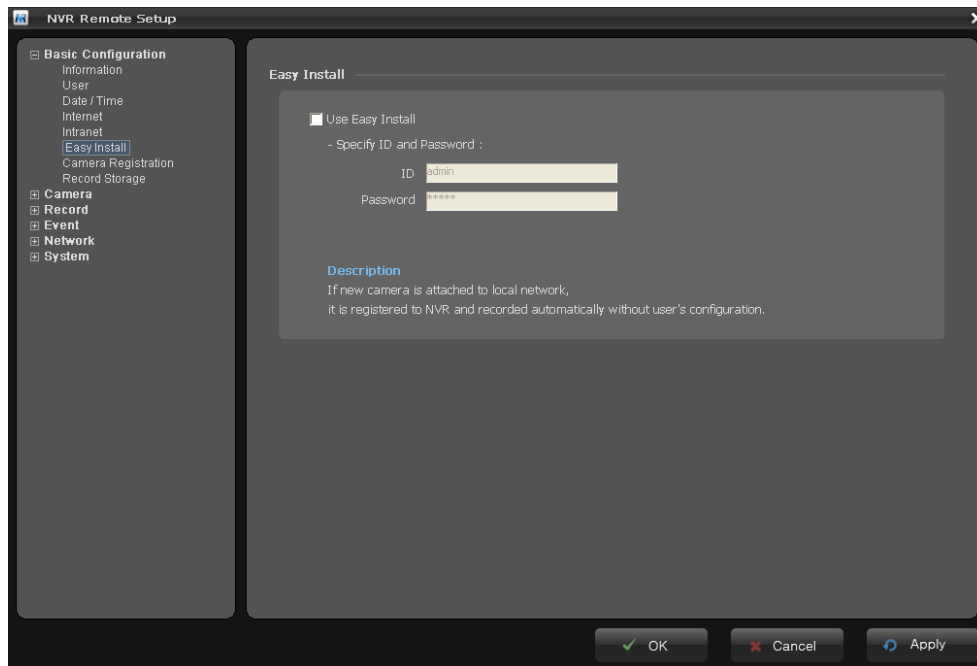

Change the admin password or use the default password (admin) of cameras to be detected. If you don't want to use easy install function, inactivate checkbox. Click the Next button to go to next page.

**Note:** Easy Install is inactivated in default. This ensures the NVR detects Vista VK2 cameras and registers automatically.

## 3.1.6 Camera Registration

You must register devices on the NVR system in order to perform any operation.

**Note:** If the NVR has activated the Easy Install function, skip this page and refer to [step3] of Chapter 2.3.

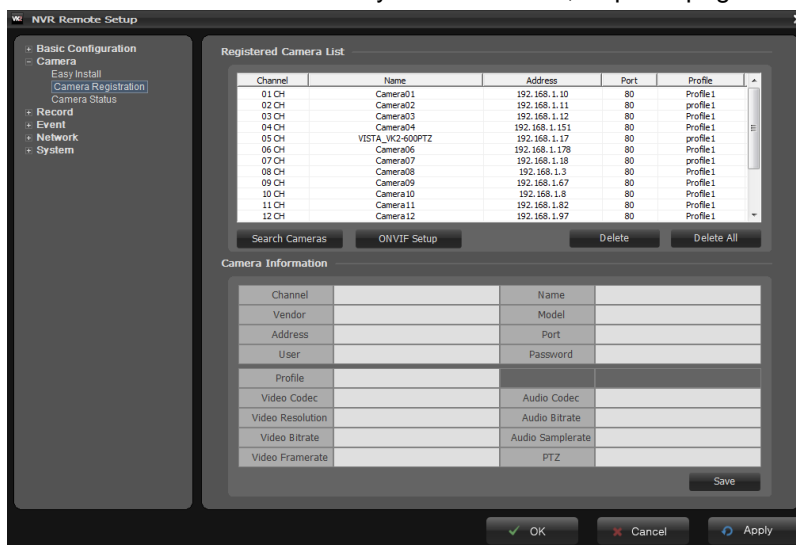

Refer to [step3] of Chapter 2.3 for more detail operation.

## 3.1.7 Record Storage

The list of available hard disk drives is displayed with the information of the hard disk drives. Select a hard disk drive from the list and click the Format button in case of unformatted storage.

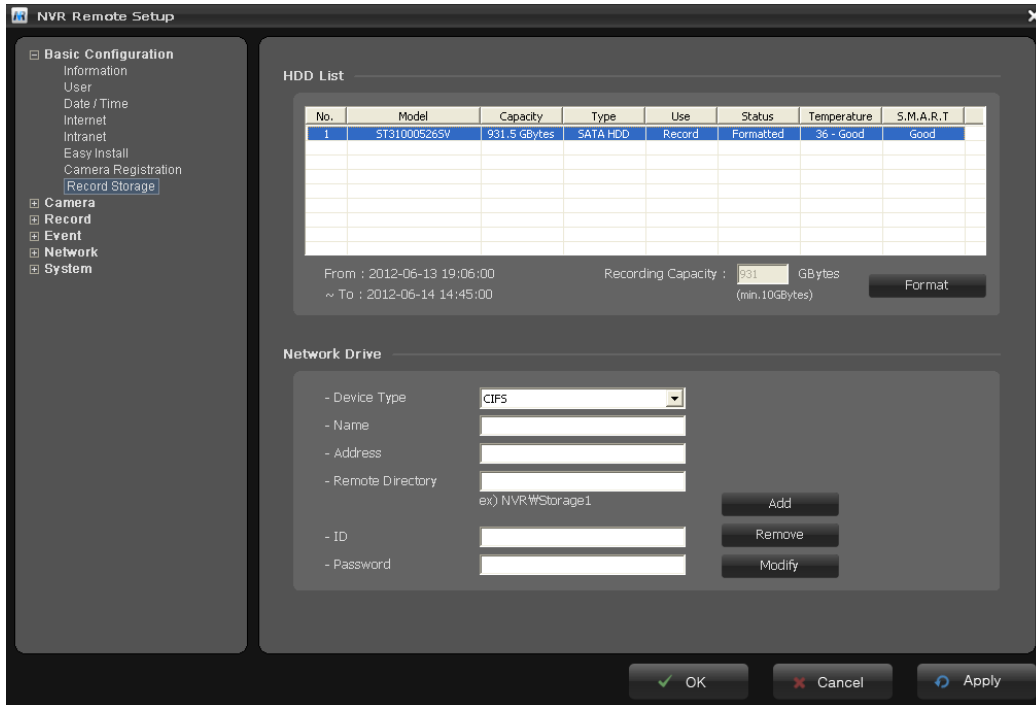

- HDD List

On top of the screen the types and statuses of internal HDDs, external HDDs, and/or NAS devices currently connected to the system are listed.

Select a hard disk drive from the list and click the Format button in case of unformatted storage.

When you click the Format button, the NVR asks you to set the storage to record or archive device. If the storage is formatted to archiving device, it can be used as a record storage.

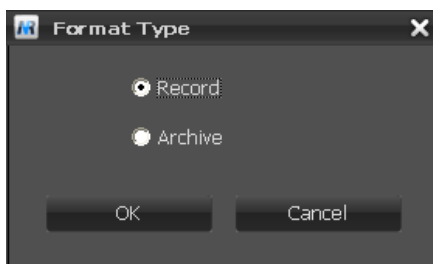

Note: Archive records a video to the record storage and copies it to the archive storage at the same time. The external USB HDD can be set to backup device only.

Please refer to “5.2 Comprehension about Archive and BACKUP function” for more information.

The current temperature of the hard disk will be displayed in the Temperature column. The Temperature column displays Good if the temperature is below the limit and Bad if the temperature is above the limit.



If the hard disk installed in the NVR supports S.M.A.R.T. (Self-Monitoring Analysis and Reporting Technology) monitoring program, the status of the installed IDE hard disk is displayed. The current status of the Disk S.M.A.R.T. will be displayed in the S.M.A.R.T column. The S.M.A.R.T field displays Good if the Disk S.M.A.R.T. is good and Bad if it is bad. The Disk Temperature and S.M.A.R.T. status is monitored in real-time.

- Network Drive

\* **Device Type:** Select Device Type to be recorded in the drop-down list.

- . CIFS: A file format for a NAS device.

- . NFS: A file format for a NAS device.

\* **Address:** Enter IP address for NAS device.

\* **Remote Directory:** Enter directory or folder location to be recorded in the NAS device.

\* **ID/Password:** Enter ID and Password. The network camera will ask them whenever you access NAS device.

\* **Capacity:** Enter the capacity of storage to be used. It must be less than the total storage capacity.

Select a NAS device from the list and click the Format button in case of unformatted storage. You must enter total size to be used in Recording Capacity before formatting.

**Note1:** Common Internet File System (CIFS) is a remote file access protocol that forms the basis for Windows file sharing, network printing, and various other network services. CIFS requires a large number of request/response transactions and its performance degrades significantly over high-latency WAN links such as the Internet.

**Note2:** Network File System (NFS) is a network file system protocol, allowing a user on a client computer to access files over a network in a manner similar to how local storage is accessed. NFS, like many other protocols, builds on the Open Network Computing Remote Procedure Call (ONC RPC) system.

## 3.2 Camera Setup

You can set the NVR to detect and register your cameras connected from network.

### 3.2.1 Easy Install

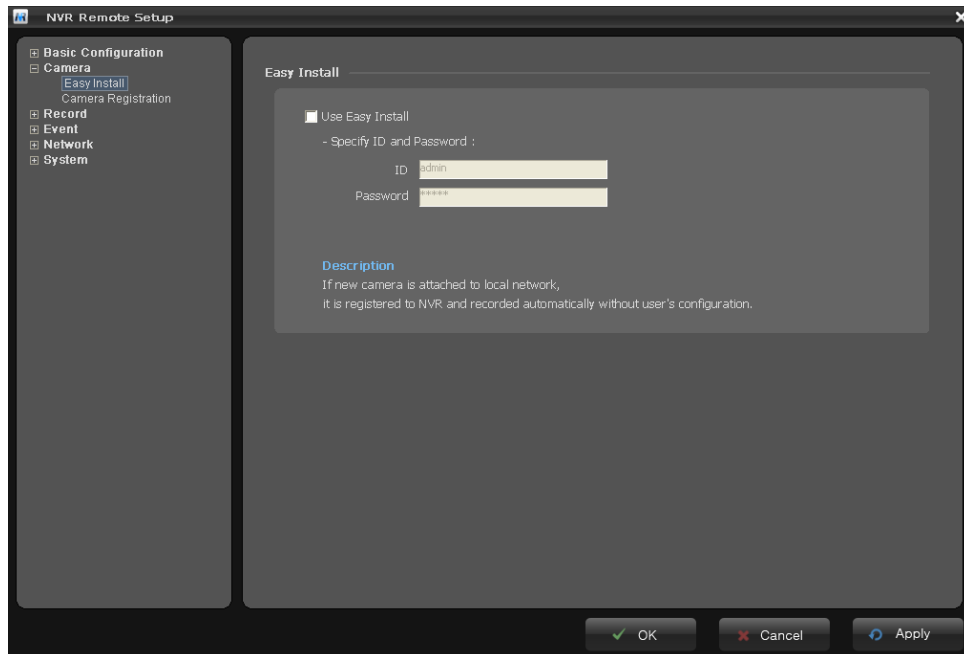

Refer to [step3] of Chapter 2.3 for more detail operation

## 3.2.2 Camera Registration

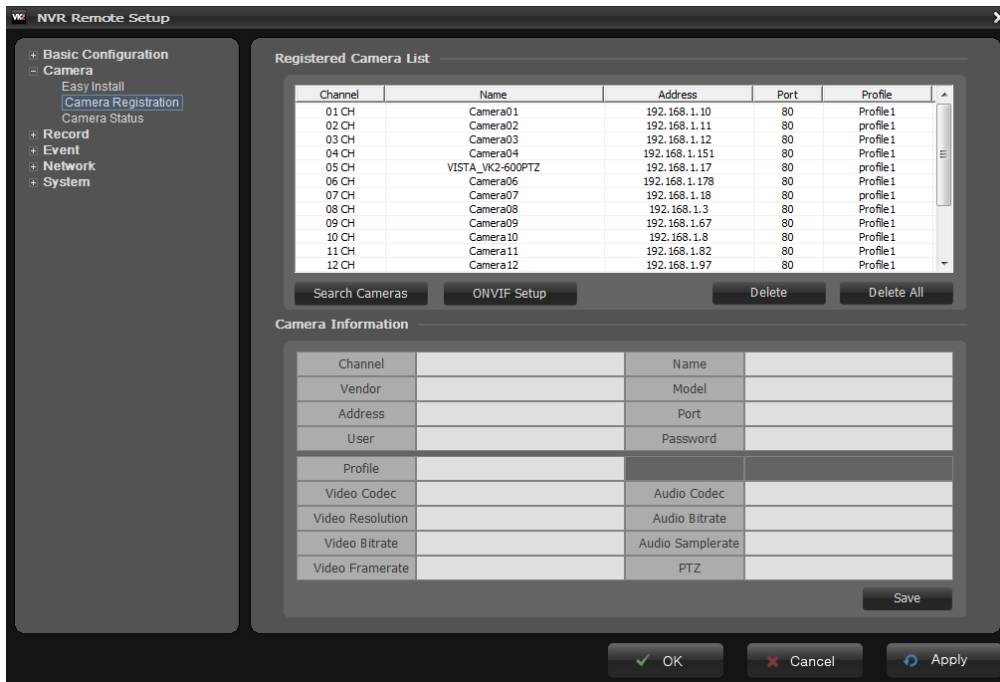

The NVR searches and displays all cameras connected in the internet besides the intranet. All cameras are displayed in the camera list.

**Note:** The NVR supports only Vista VK2 cameras.

- **Camera Information**

Click a camera in the camera list, and the NVR displays camera information in the Camera Information section.

- **Name:** Displays the camera name.
- **Address:** Displays the camera's IP address.
- **Port:** Displays the port numbers.
- **ID: Password:** The user ID and password for connection to the device.
- **Profile:** Displays the ONVIF profile.
- **Protocol:** Displays the protocol for streaming
- **Vendor:** Displays the camera manufacturer.
- **Model:** Displays the model name.

- Search Camera  
Click the Search Cameras button to search cameras and the Camera Discovery window appears. Select one of three in Search Mode and click the Start Search button.

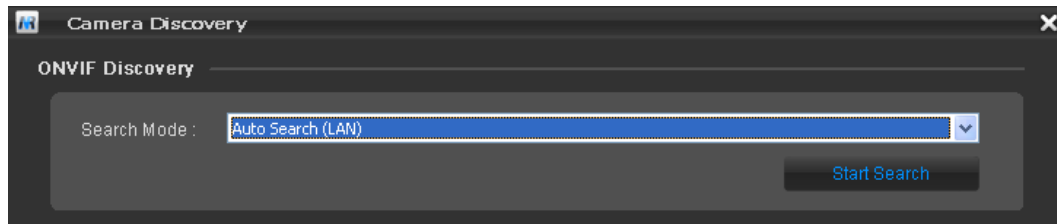

## - Search Mode:

- \* Auto Search (LAN): Lists cameras in a LAN environment.
- \* IP Search (Single): Allows you to enter the IP address of a device. You can search more than one device at a time by entering a range of IP addresses.
- \* Domain Name Search: Allows you to enter the domain name registered on a DDNS server if the camera uses the DDNS function.

All cameras detected are displayed in the list. Display the name and IP address the selected camera. The name will be updated automatically depending on the settings of the network camera.

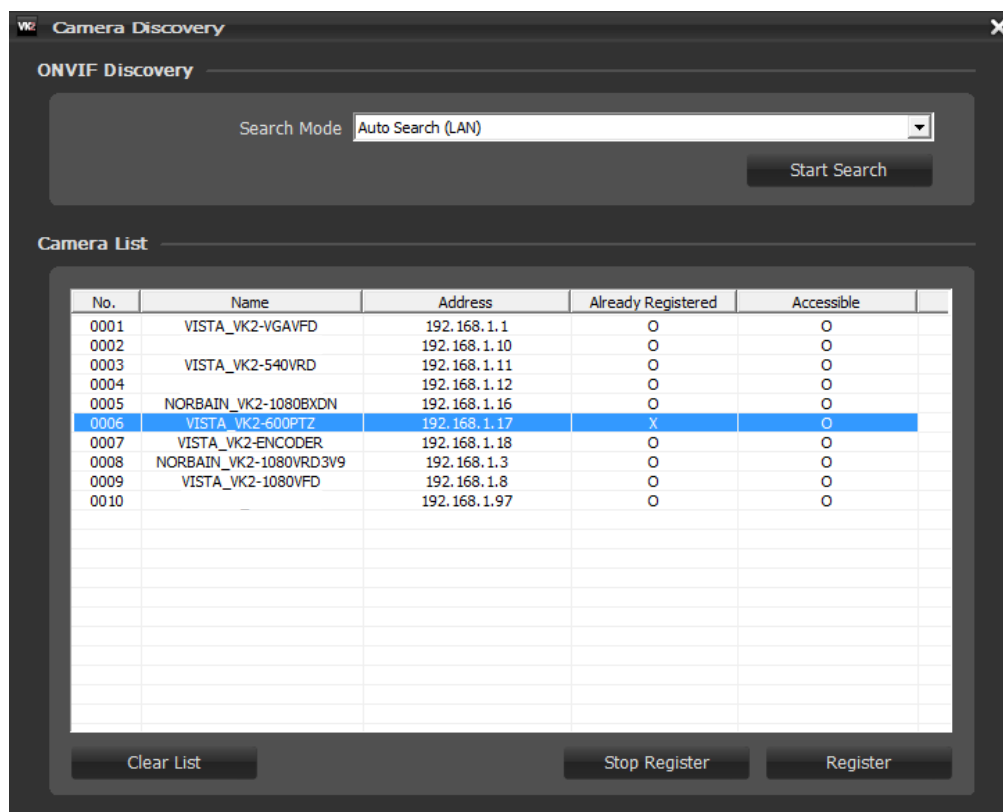

Select one or several cameras from the list and click the Register button to register. The Login window appears and inquires ID and Password.

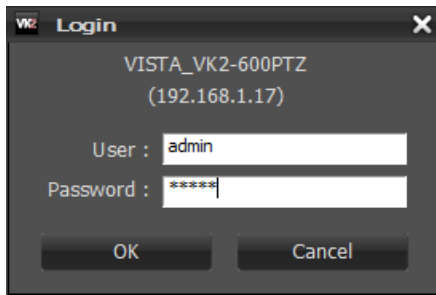

[One camera selection]

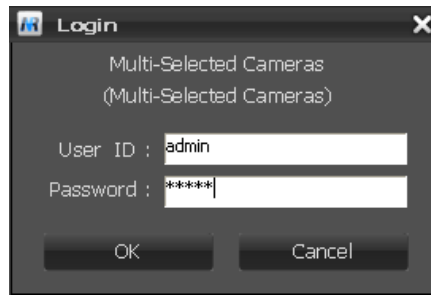

[Several camera selection]

Enter the user ID and password which you set in the device in order to connect to that camera remotely. Only the admin user is allowed to connect to a network camera device.

You can see the result in the Already Registered column of the ONVIF Discovery window whether succeed in registration or not.

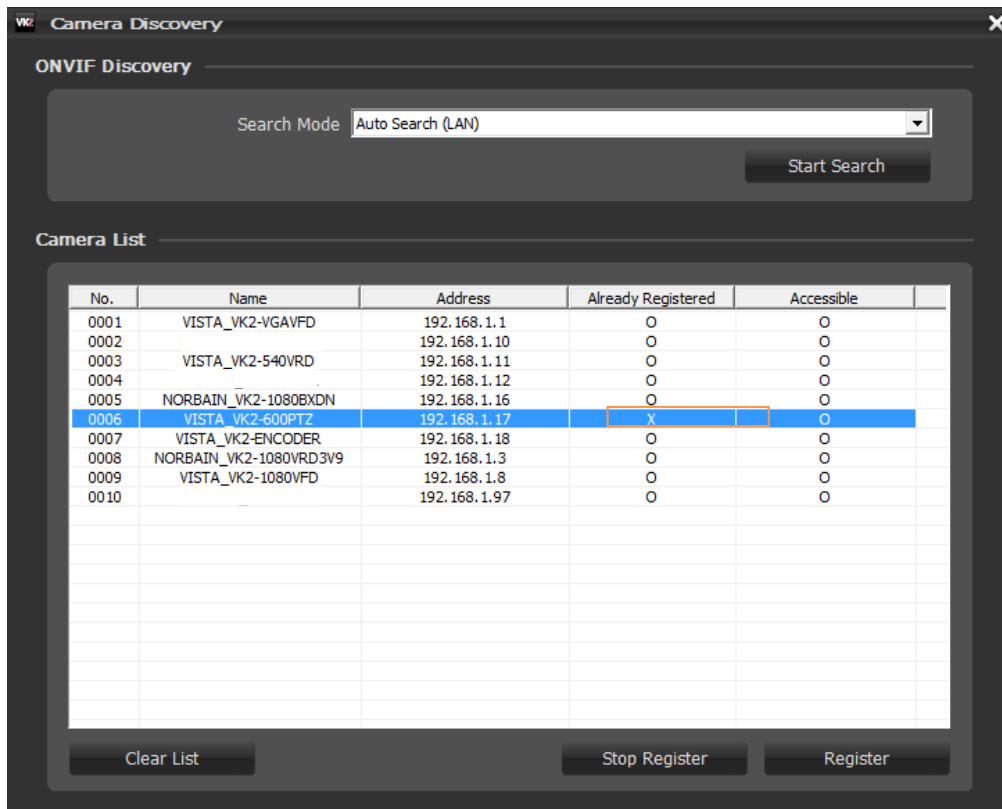

The NVR displays the registered camera list in Camera Registration window.

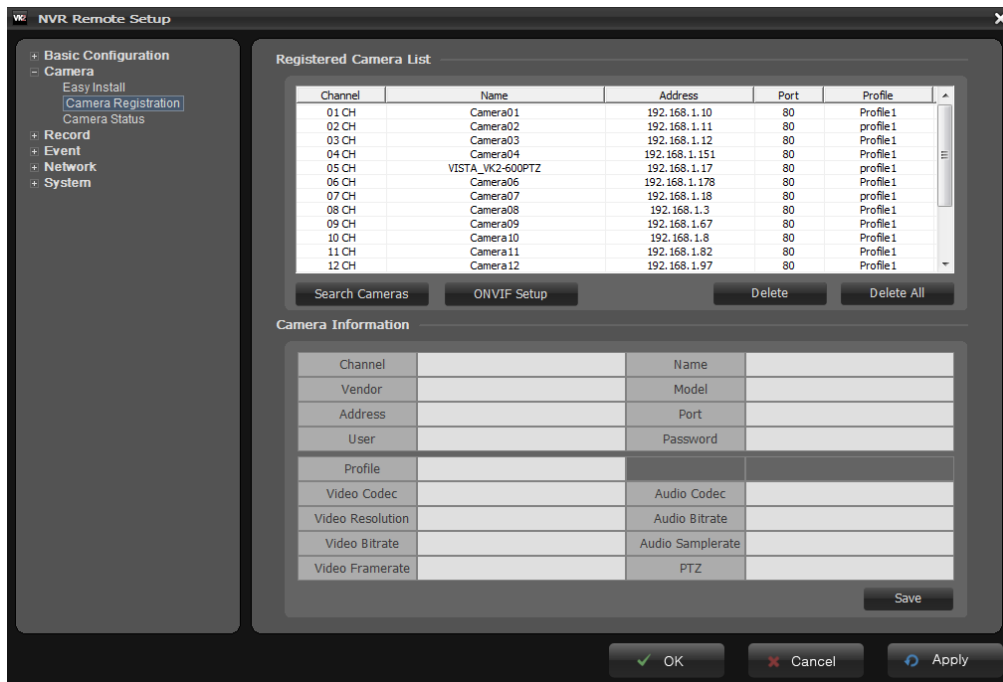

When you select a camera channel in the list, the basic information for that camera is displayed in Camera Information section. Configure camera settings you want to change. Click the Save button to save settings changed.

- **Onvif Setup**  
Click the Onvif Setup button in the Camera Registration window to configure more detail information for a selected camera. You can configure camera settings about Video, Audio, Profile, and Network.

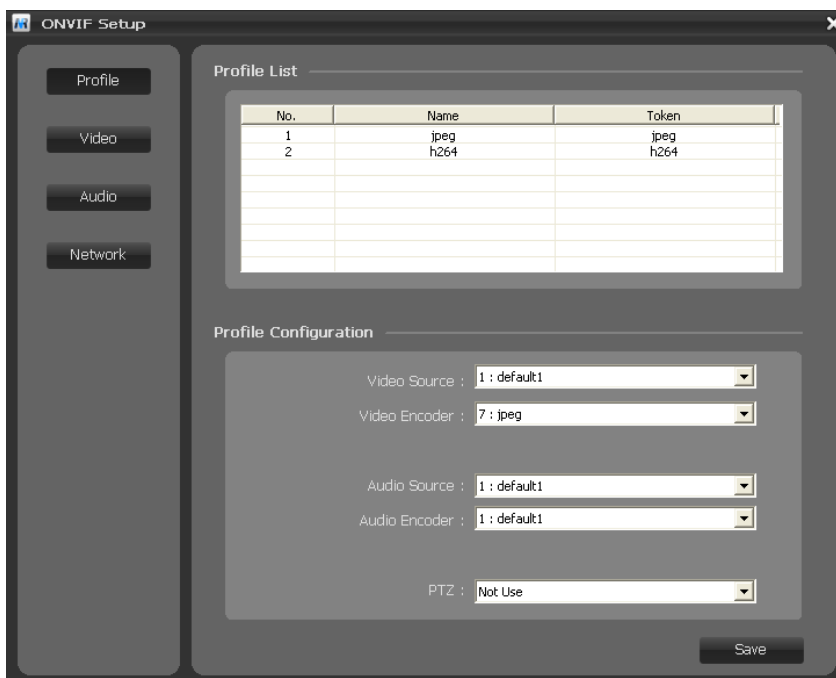

The network camera provides access to H.264, and Motion JPEG video streams, and to the list of available stream profiles. The NVR and clients can also access these video streams/images directly.

The number of profile depends on the kind of camera device.

- **Profile:** Select a profile from the profile list. The NVR displays live video based on the settings of the selected profile. Each profile consists of stream characters, describing its audio and video encoder, PTZ control.

\* Video Source: Select the desired video source from the list of video sources supported in the device.

\* Video Encoder: Select a video encoder configuration.

\* Audio Source: Select a desired audio source from the list of audio sources supported in the device. When Not Use is selected, audio monitoring and recording for the device will not be supported.

\* Audio Encoder: Select an audio encoder configuration.

\* PTZ: Select a PTZ setting. When Not Use is selected, PTZ control of the device will not be supported.

- **Video:** Set up an encoder for video. Select a video source to configure in the Source list. Clicking the Video button allows you to configure the details of the selected video encoder configuration.

\* Token: The number of tokens.

\* Name: Assign a name to the selected video encoder.

\* Codec: Select a video compression codec.

\* Resolution: Select a video resolution.

\* Quality: Set the video quality.

\* Bitrate: Enter the maximum bit rate. You can control the network bandwidth by limiting the bit rate depending on the network traffic.

\* Framerate: Select a maximum frame rate.

The screenshot shows the ONVIF Setup window with a sidebar on the left containing buttons for Profile, Video, Audio, and Network. The main area is divided into two sections: Source List and Encoder Configuration.

**Source List:** A table with columns No., Name, and Token. It contains one entry: No. 1, Name default1, Token 1.

No.	Name	Token
1	default1	1

**Encoder Configuration:** A form with the following fields:

- Token: 1 (dropdown)
- Name: default1 (text input)
- Codec: JPEG (dropdown)
- Resolution: 640\*480 (dropdown)
- Quality: 50 (dropdown)
- Bitrate: 0 (text input)
- Framerate: 30 (dropdown)

A Save button is located at the bottom right of the Encoder Configuration section.

- **Audio:** Set up an encoder for audio. Select an audio source to configure in the Source list. Clicking the Audio button allows you to configure the details of the selected audio encoder configuration.

\* **Token:** The number of tokens.

\* **Name:** Assign a name to the selected video encoder.

\* **Codec:** Select an audio compression codec.

\* **Bitrate:** Enter the maximum bit rate. You can control the network bandwidth by limiting the bit rate depending on the network traffic.

\* **Sampling rate:** Select the sampling rate. The higher the value is, the better the sound quality and the larger the data size.

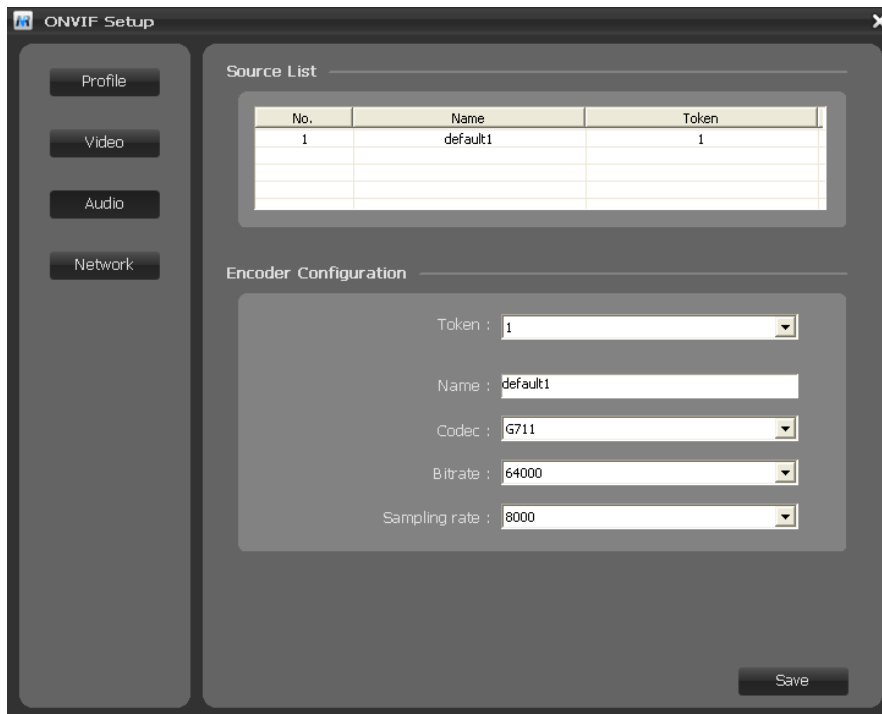



- **Network:** Set up IP Address.

\* Obtain IP address via DHCP:

Dynamic Host Configuration Protocol (DHCP) is a protocol that lets network administrators centrally manage and automate the assignment of IP addresses on a network. DHCP is enabled by default. Although a DHCP server is mostly used to set an IP address dynamically, it is also possible to use it to set a static, known IP address for a particular MAC address.

\* Use the following IP address:

To use a static IP address for the NVR, check the radio button and then make the following settings:

- IP address: Specify a unique IP address for the NVR.
- Subnet mask: Specify the mask for the subnet the NVR is located on.
- Default router: Specify the IP address of the default router (gateway) used for connecting devices attached to different networks and network segments.

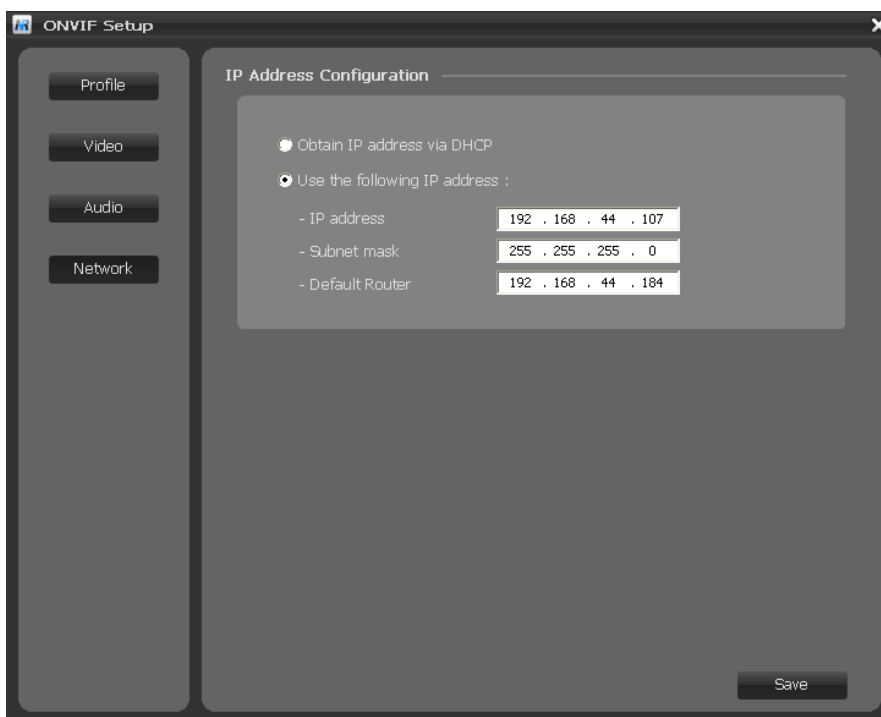

## 3.1.3 Record

### 1) Storage

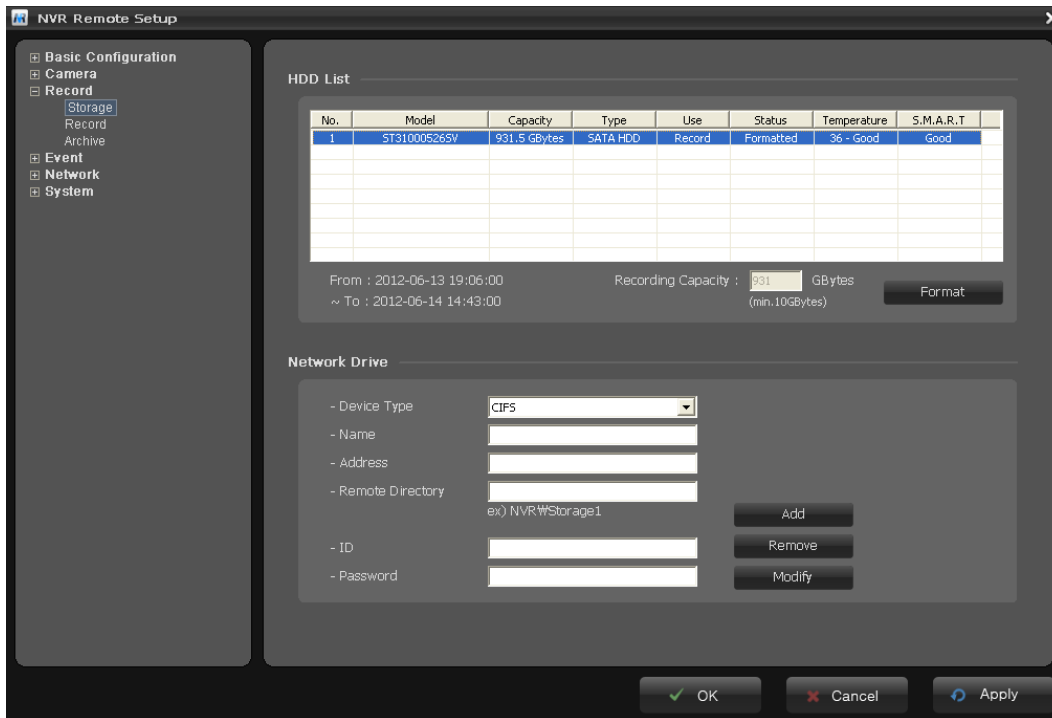

Refer to “Record Storage of Chapter 3.1.1”.

### 2) Record

Set a weekly recording schedule for each channel. A combination of a schedule and an event is possible.

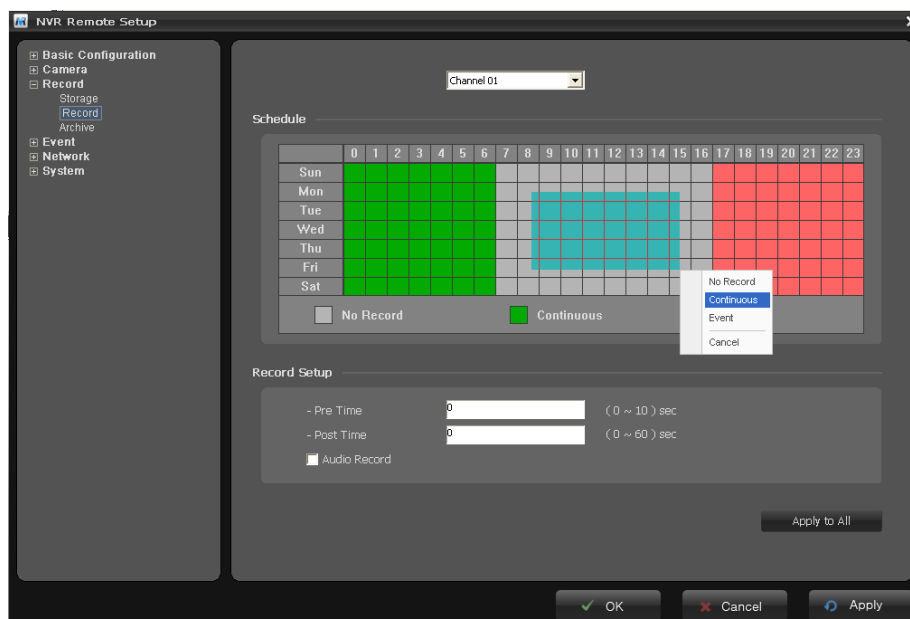

- Schedule

Drag or click area by a box unit at first. A pop up window will appear. Then, set recording settings for the corresponding day. Click the “Apply to All” button to apply the same settings to all channels.

- Record Setup

- Pre Time: Enter the pre-recording time. When the NVR is in the Event Record mode it is possible to have it record images before the event occurs.

- Post Time: Enter the post-recording time. When the NVR is in the Event Record mode it is possible to have it record images after the event occurs.

- Audio Record: Mark checkbox to activate audio recording.

Click the OK button to save your changes and exit the schedule setup screen.

## 3) Archive

The NVR supports schedule data backup which archives periodically video data in record storage to archive storage. You can set storages to record or archive device when configuring them.

You can change configurations for the control of all archive devices and for the archive of recorded data in this menu.

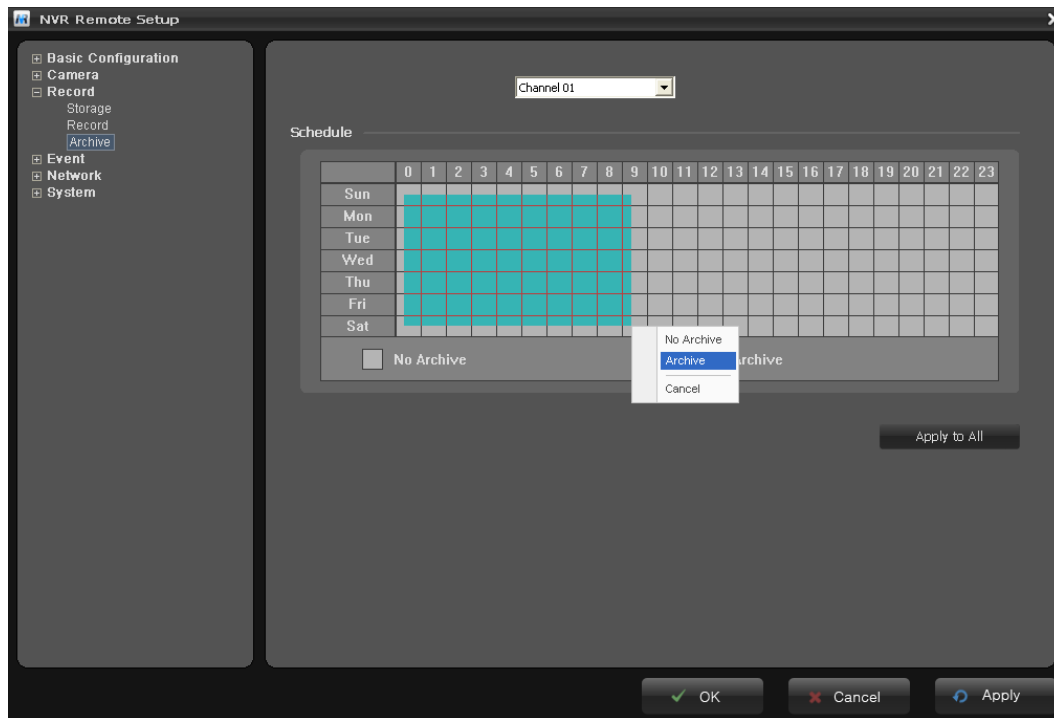

- Schedule

Drag or click area by a box unit at first. A pop up window will appear. Then, set archiving settings for the corresponding day. Click the “Apply to All” button to apply the same settings to all channels.

### 3.1.4 Event

This menu allows setting event options such as Alarm-In, Motion, Video Loss, System Event, and Log. The NVR starts recording with settings configured here when an event occurs. The types of event include External Alarm, Motion Detection, Video Loss, and System Event. An occurred event can be notified by Alarm Output (2 Channel), and Email.

## 1) Alarm

You can configure settings for the alarm input from network cameras, or from the NVR.



Set the On/Off, Dwell Time, Action, Recording. Click each column in the list to configure settings.

- **Camera Alarm Event**

- **On/Off:** Choose an item from the drop-down list. When an item is On, the event for alarm input is activated.
- **Dwell Time:** Set the dwell time an event lasts for the specified dwell time from the point of detection of an alarm input.
- **Action:** Set the actions the NVR will take whenever it senses an alarm input. Select items in the pop-up Action screen.
  - \* E-mail: Select email addresses you want to send via email that an event has occurred.
  - \* HTTP: The NVR sends notification messages to an HTTP server that listens for these. The destination server must first be configured on the Network page for a proper operation.
  - \* Alarm: The NVR can control external equipment connected to its alarm output port.
- **Recording:** Select the cameras that you want the NVR to record whenever it detects an alarm input. Select items in the pop-up Recording screen.

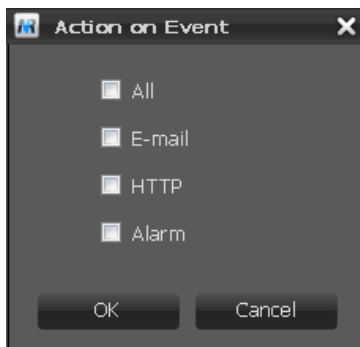

- **NVR Alarm Event**

The NVR have 2 input and 2 output alarm ports for itself.

- **On/Off:** Choose an item from the drop-down list. When an item is On, the event for alarm input is activated.
- **Dwell Time:** Set the dwell time an event lasts for the specified dwell time from the point of detection of an alarm input.
- **Type:** Choose the type of alarm you wish to use from the drop-down list.
- **Action:** Set the actions the NVR will take whenever it senses an alarm input. Select items in the pop-up Action screen.
- **Recording:** Select the cameras that you want the NVR to record whenever it detects an alarm input. Select items in the pop-up Recording screen.

## 2) Motion

You can configure settings for the motion event.



Set the On/Off, Dwell Time, Action, Recording. Click each column in the list to configure settings.

- **Motion Event**

- **On/Off:** Choose an item from the drop-down list. When an item is On, the motion event is activated.
- **Dwell Time:** Set the dwell time an event lasts for the specified dwell time from the point of detection of a motion event.
- **Action:** Set the actions the NVR will take whenever it senses a motion event. Select items in the pop-up Action screen.
- **Recording:** Select the cameras that you want the NVR to record whenever it detects a motion event. Select items in the pop-up Recording screen.

### 3) Video Loss

You can configure settings for the video loss event. When there is a channel with no input stream from the network camera, it can be processed as an event.

The screenshot shows the 'NVR Remote Setup' window with a sidebar on the left containing a tree view of configuration categories: Basic Configuration, Camera, Record, Event (with sub-items Alarm, Motion, Video Loss, System), Text-In, Network, and System. The main area is titled 'Video Loss Event' and contains a table with 16 rows. Each row represents a configuration entry with columns for No., On/Off, Dwell Time, Action, and Recording. At the bottom of the window are three buttons: OK, Cancel, and Apply.

No.	On/Off	Dwell Time	Action	Recording
01	Off	3	All	All
02	Off	3	E-mail, HTTP, Alarm1	1, 3, 4
03	Off	3	HTTP, Alarm1, Alarm2	5, 6, 7, 8
04	Off	3	E-mail	9, 10, 11, 12
05	Off	3	HTTP	13, 14, 15, 16
06	Off	3	E-mail	1, 5, 9, 13
07	Off	3	HTTP	2, 6, 10, 14
08	Off	3	All	3, 7, 11, 15
09	Off	3	All	3, 4, 7, 8, 11, 12, 15, 16
10	Off	3	Alarm1, Alarm2	4, 8, 12, 16
11	Off	3	Alarm1, Alarm2	1, 2, 3, 4, 5, 6, 7, 8, 9, 10, 12, 13, 14, 15, 16
12	Off	3	E-mail	1, 2, 3, 4, 5, 6, 7, 8, 9, 10, 11, 13, 14, 15, 16
13	Off	3	E-mail, HTTP	1, 2, 3, 4, 5, 6, 7, 8, 9, 10, 11, 12, 14, 15, 16
14	Off	3	HTTP	1, 2, 3, 4, 5, 6, 7, 8, 9, 10, 11, 12, 13, 15, 16
15	Off	3	All	1, 2, 3, 4, 5, 6, 7, 8, 9, 10, 11, 12, 13, 14, 16
16	Off	3	All	1, 2, 3, 4, 5, 6, 7, 8, 9, 10, 11, 12, 13, 14, 15

Set the On/Off, Dwell Time, Action, Recording. Click each column in the list to configure settings.

- **Video Loss Event**

- **On/Off:** Choose an item from the drop-down list. When an item is On, the event for alarm input is activated.
- **Dwell Time:** Set the dwell time an event lasts for the specified dwell time from the point of detection of a video loss.
- **Action:** Set the actions the NVR will take whenever it senses a video loss. Select items in the pop-up Action screen.
- **Recording:** Select the cameras that you want the NVR to record whenever it detects a video loss. Select items in the pop-up Recording screen.

#### 4) System

You can configure settings for the system event. The Disk Temperature and S.M.A.R.T. in the System Event are supported.

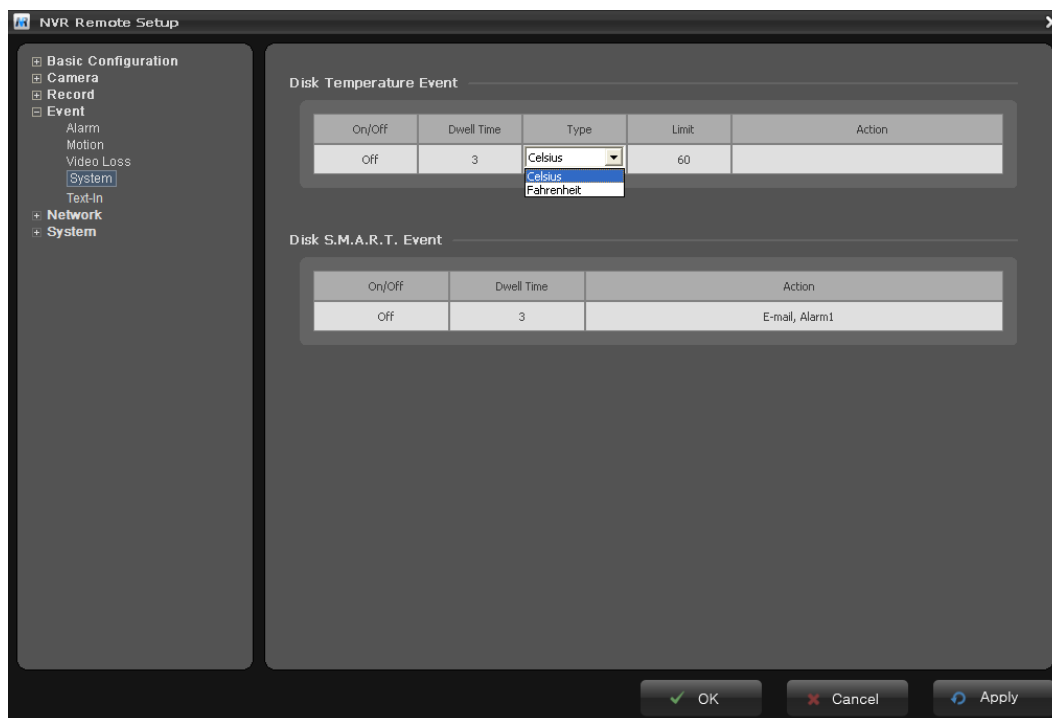

- **Disk Temperature Event**

- **On/Off:** Choose an item from the drop-down list. When an item is On, the event for disk temperature event is activated.
- **Dwell Time:** Set the dwell time an event lasts for the specified dwell time from the point of detection of a disk temperature event.
- **Type:** Choose the type of temperature you wish to use from the drop-down list. Select either °C (Celsius) or °F (Fahrenheit).
- **Limit:** Choose the limit of temperature you wish to use from the drop-down list. You can set the Disk Temperature, and the NVR will trigger an alert whenever it exceeds the defined threshold temperature.
- **Action:** Set the actions the NVR will take whenever it senses a video loss. Select items in the pop-up Action screen.



- **Disk S.M.A.R.T Event**

- **On/Off:** Choose an item from the drop-down list. When an item is On, the event for S.M.A.R.T event is activated.
- **Dwell Time:** Set the dwell time an event lasts for the specified dwell time from the point of detection of S.M.A.R.T event.
- **Action:** Set the actions the NVR will take whenever it senses S.M.A.R.T event. Select items in the pop-up Action screen.

**Note:** The Disk Temperature and S.M.A.R.T. status is monitored in real-time. Temperature and S.M.A.R.T. information will be available only for hard disk drives supporting the SMART (Self-Monitoring Analysis and Reporting Technology) monitoring program.

## 5) Text-In

You can configure settings for the text-in event.

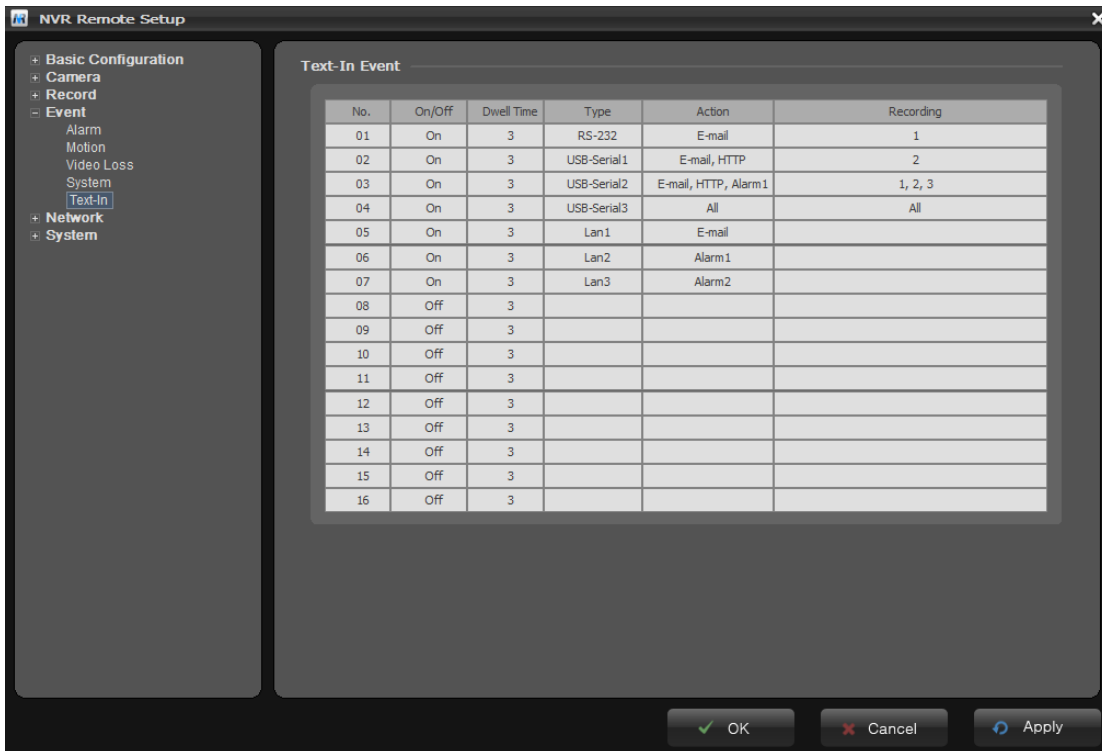

Set the On/Off, Dwell Time, Type, Action, Recording. Click each column in the list to configure settings.

- **Text-In Event**

- **On/Off:** Choose an item from the drop-down list. When an item is On, the text-in event is activated.
- **Dwell Time:** Set the dwell time an event lasts for the specified dwell time from the point of detection of a text-in event.
- **Type:** Set the type and additional configuration such as port, baudrate, protocol and so on of text-in device.
- **Action:** Set the actions the NVR will take whenever it senses a text-in event. Select items in the pop-up Action screen.
- **Recording:** Select the cameras that you want the NVR to record whenever it detects a text-in event. Select items in the pop-up Recording screen.

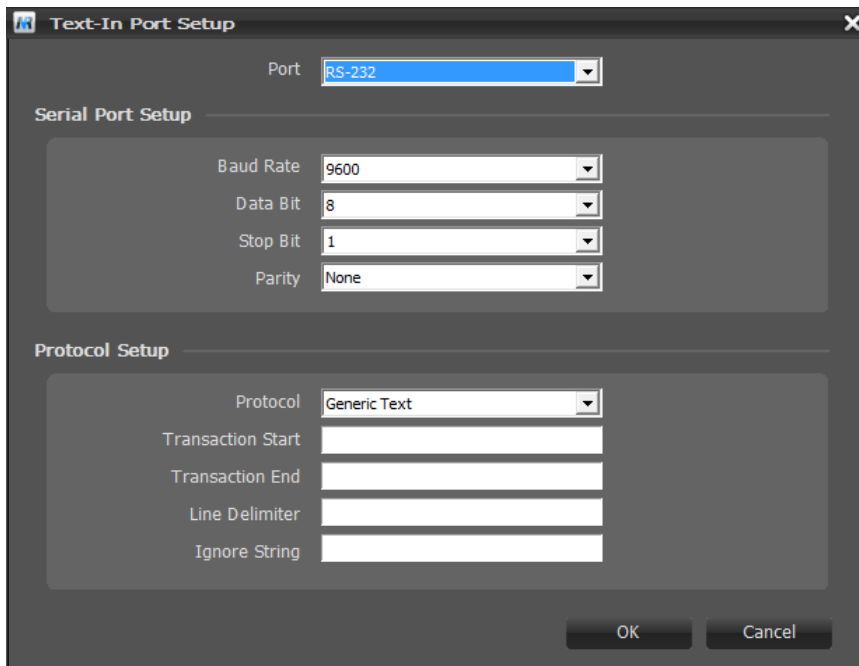

- **Port Setup**
  - . **Port:** Select from RS-232, USB-Serial(1~16) and Lan(1~16).
  - . **Serial Port Setup:** If RS-232 or USB-Serial is selected, set baud rate, data bit, stop bit and parity depending on text-in device.
  - . **Network Port Setup:** If Lan is selected, set the network port depending on text-in device.
  - . **Protocol Setup:** Currently only generic text device is supported. Set the other configurations depending on text-in device.

## 3.1.5 Network

Setting in regard to network can be executed. Settings for IP, DNS, Host Name, Port, and ARP/Ping can be established, along with setting for SNMP, DDNS, uPnP, QoS, NAT Traversal, Zeroconfig, and Bonjour.

### 1) Internet

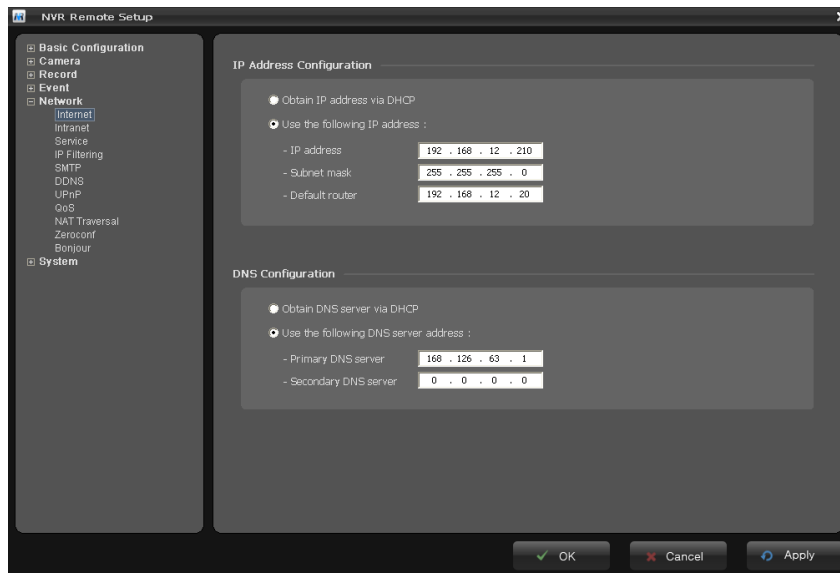

Refer to “Internet of Chapter 3.1.1”.

### 2) Intranet

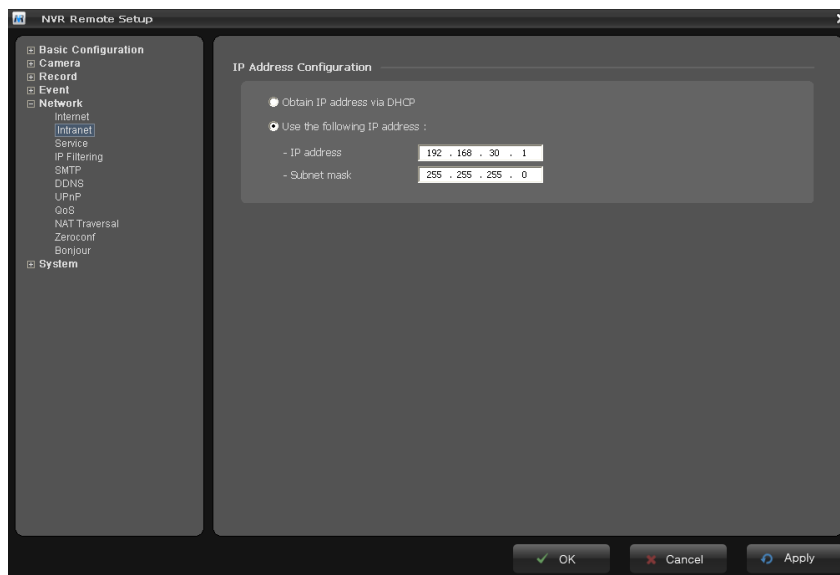

Refer to “Intranet of Chapter 3.1.1”.

## 3) Service

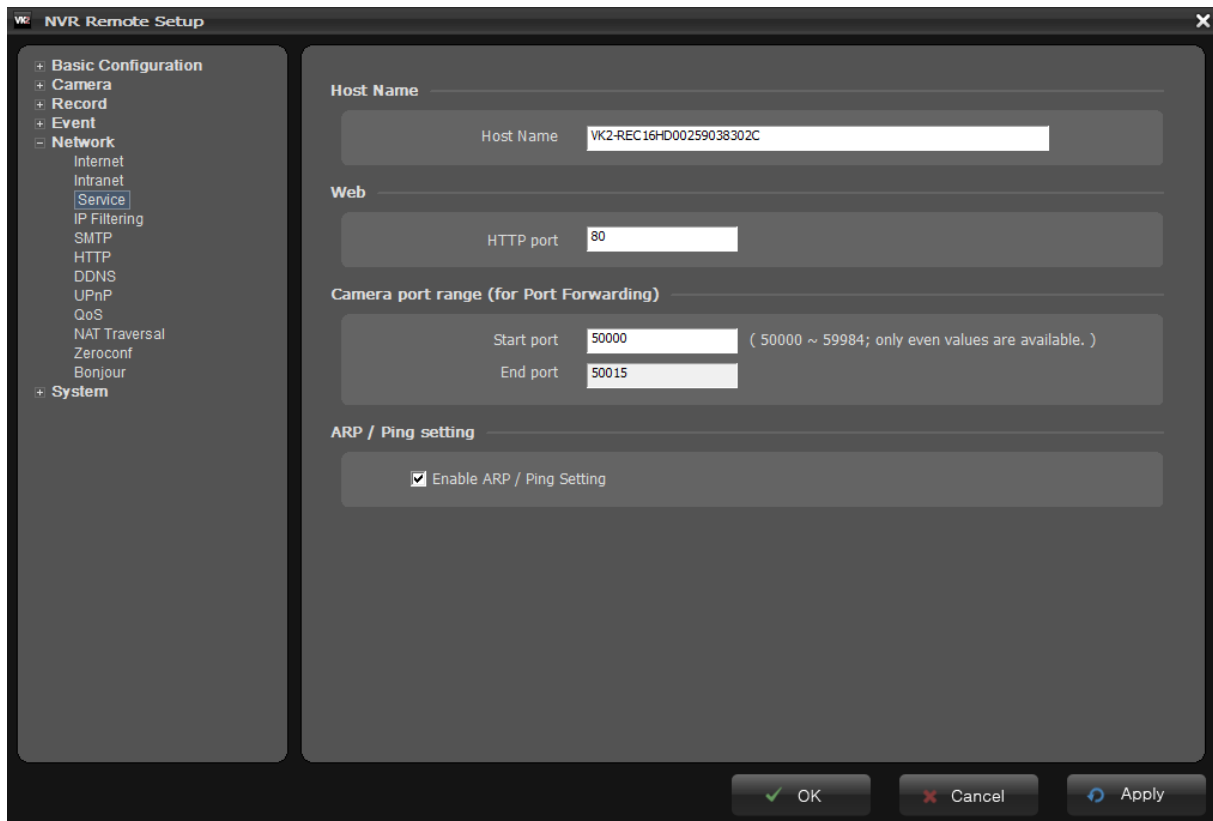

- **Host Name Configuration**
  - **Host Name** – enter the host name to be used as device information in the client software or SmartManager.
- **Services**
  - **HTTP port:** Enter a port to receive a service through the HTTP. Default Port Number is '80'.
- **Web port range**

The NVR acts as the port forwarding device like a router when you access network cameras connected on a camera (LAN) port of the NVR from the other (WAN) side through a client port of the NVR.

  - **Start port:** Enter a starting port number to be mapped as router. Default Port Number is '50000'.
  - **End port:** Displays an ending port number for the router in the field provided.
- **ARP/Ping Setting**
  - Enable ARP/Ping setting of IP address - The IP address can be set using the ARP/Ping method, which associates the unit's MAC address with an IP address. Check this box to enable the service.  
Leave disabled to prevent unintentional resetting of the IP address.

## 4) IP Filtering

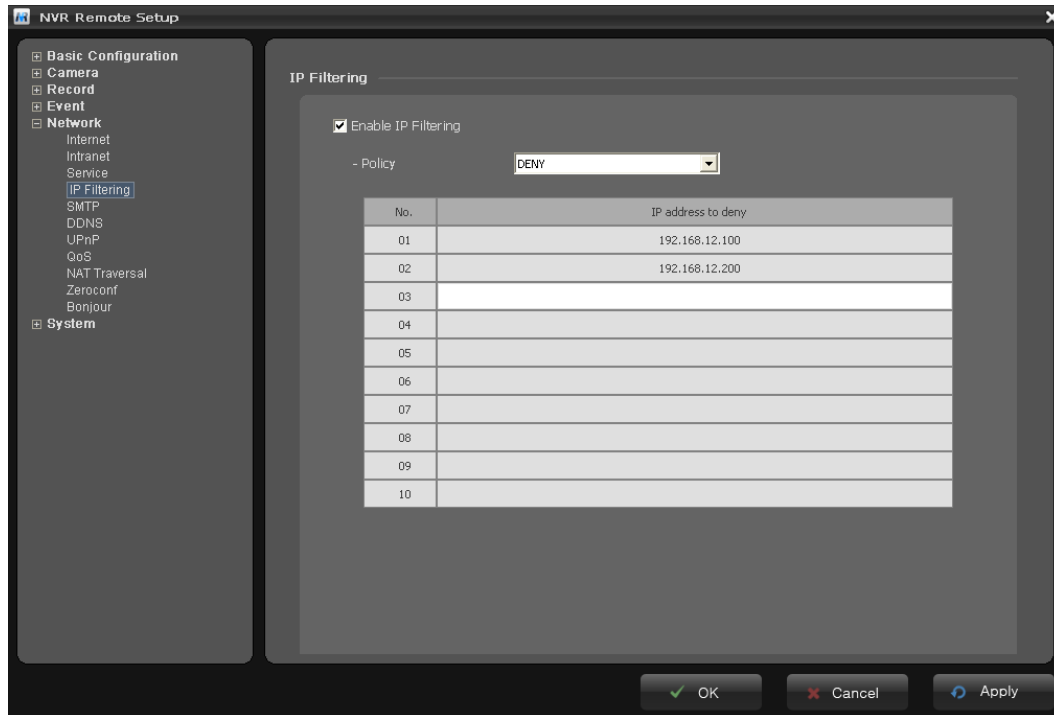

Checking the **Enable IP address filtering** box enables the IP address filtering function. Up to 10 IP addresses can be specified. Click a column of the list and enter new filtered addresses.

When the IP address filter is enabled, addresses added to the list are set as allowed **or** denied addresses. All other IP addresses not in this list will then be allowed or denied access accordingly, that is, if the addresses in the list are allowed, then all others are denied access, and vice versa. See also the online help for more information.

Note that users from IP addresses that will be allowed must also be registered with the appropriate access rights (Guest, Operator or Administrator). This is done from Setup>System>Users.

## 5) SMTP

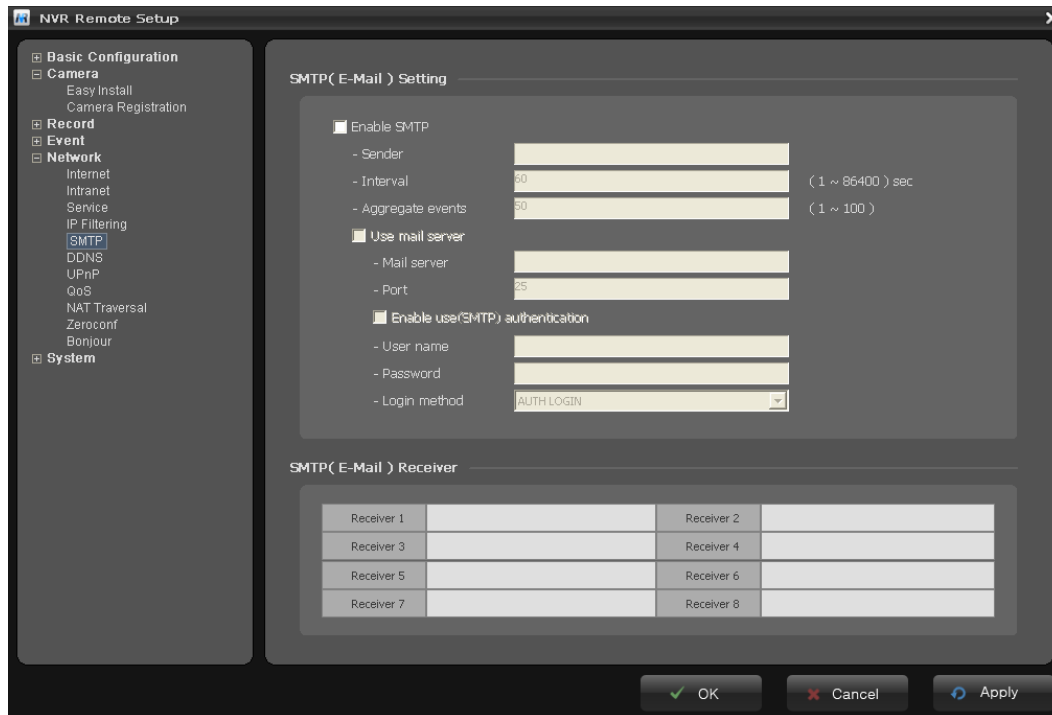

The NVR can be configured to send event and error email messages via SMTP (Simple Mail Transfer Protocol).

- **SMTP(E-Mail) Setting**

Select “Enable” to activate the SMTP operation.

- **Mail Server / Port:**

Enter the host names (or IP addresses) and port numbers for your mail server in the fields provided, to enable the sending of notifications and image email messages from the camera to predefined addresses via SMTP.

- **Sender:**

Enter the email address to be used as the sender for all messages sent by the Network Transmitter.

- **Interval:**

Represent the frequency of the email notification when an event occurs.

- **Aggregate events:**

Shows the maximum number of emails sent within each interval.

If your mail server requires authentication, check the box for Use authentication to log in to this server and enter the necessary information.

- **User Name/Password:**

Enter the User Name and Password as provided by your network administrator or ISP (Internet Service Provider).

To ensure that the login procedure is performed as securely as possible when using SMTP authentication, you must define the weakest authentication method allowed.

## - Login Method:

Set the Weakest method allowed to the highest/safest method supported by the mail server.

The most secure method is listed in the drop-down list:

Login / Plain

## • SMTP(E-Mail) Receiver

### - Receiver:

Enter an email address. You can also register the e-mail address of recipients up to 8.

## • SMTP(E-Mail) Test

### - Receiver:

Enter an email address and click the Test button to test that the mail servers are functioning and that the email address is valid.

## 6) DDNS

The screenshot displays the 'NVR Remote Setup' window with the 'DDNS' configuration page selected in the left-hand navigation menu. The main content area is titled 'DDNS' and features a checkbox for 'Enable DDNS' which is currently checked. Below this, a 'Note' states: 'Please remember you have to configure at least primary DNS server in DNS configuration settings to use Dynamic DNS.' The configuration fields include: 'DDNS Server' (a dropdown menu showing 'cctv-network.co.kr'), 'Registered host' (a text input field), 'User name' (a text input field), 'Password' (a text input field), 'Confirm password' (a text input field), 'Maximum time interval' (a dropdown menu showing '1 hour'), and 'Register local network IP address' (a checked checkbox). Below this checkbox is a 'Registered IP address' text input field. At the bottom of the window, there are three buttons: 'OK' (with a green checkmark), 'Cancel' (with a red X), and 'Apply' (with a blue refresh icon).



- **Internet DDNS(Dynamic Domain Name Service)**

When using the high-speed Internet with the telephone or cable network, users can operate the Network Camera even on the floating IP environment in which IPs are changed at every access.

Users should receive an account and password by visiting a DDNS service like

<http://www.dyndns.com/>, or <http://www.cctv-network.co.kr/>.

- **Enable DDNS:**

Check to get DDNS service to be available.

- \* **DDNS Server:** Select the DDNS server.

- \* **Registered host:** Enter an address of the DDNS server.

- \* **Username:** Enter an ID to access to the DDNS server.

- \* **Password:** Enter a password to be used for accessing the DDNS server.

- \* **Confirm:** Enter a password again to confirm it.

- \* **Maximum time interval:** Set a time interval to synchronize with the DDNS server. Select an item in the interval drop-down list.

- \* **Register local network IP address:** Register a Network Video Server IP address to the DDNS server

## 7) UPnP

The NVR includes support for UPnP™. UPnP™ is enabled by default, and the NVR then is automatically detected by operating systems and clients that support this protocol.

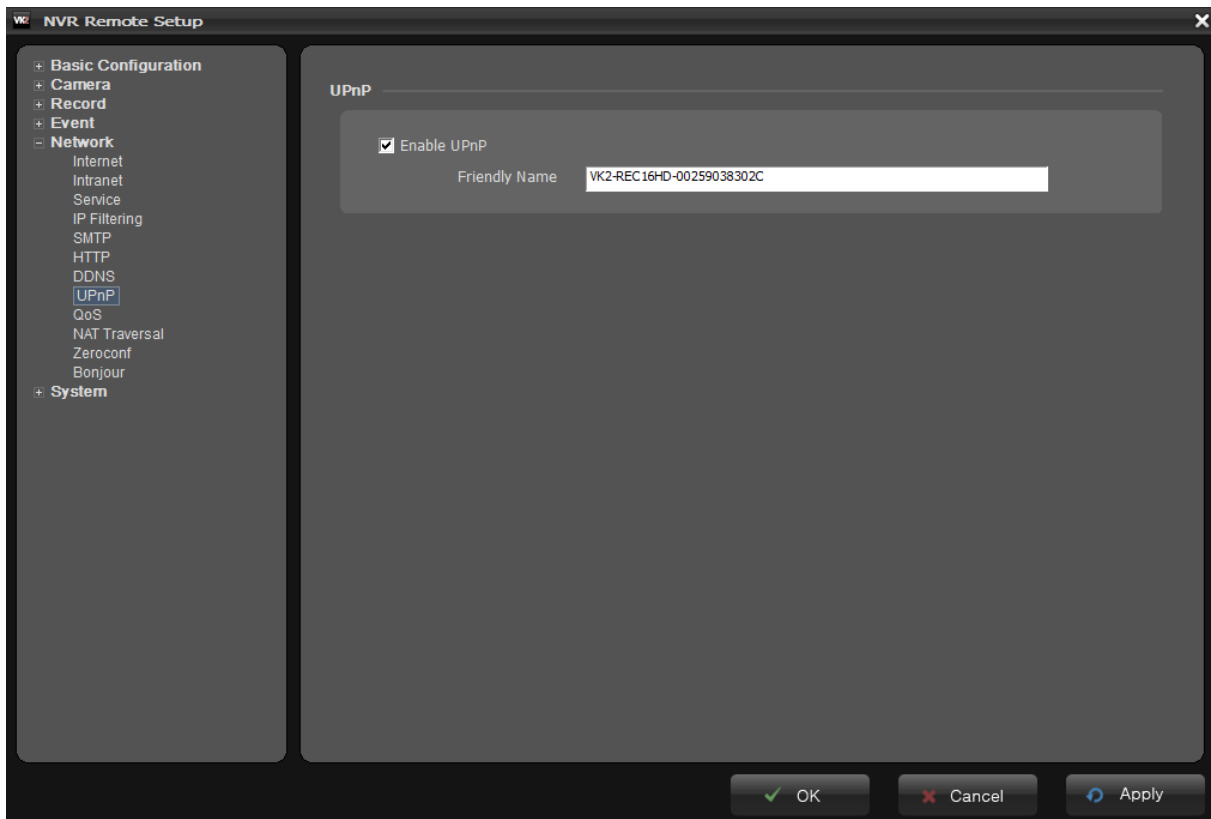

**Note:** UPnP™ must be installed on your workstation if running Windows 7 pro. To do this, open the Control Panel from the Start Menu and select Add/Remove Programs. Select Add/Remove Windows Components and open the Networking Services section. Click Details and then select UPnP™ as the service to add.

## 8) QoS

Quality of Service (QoS) provides the means to guarantee a certain level of a specified resource to selected traffic on a network. Quality can be defined as a maintained level of bandwidth, low latency, and no packet losses.

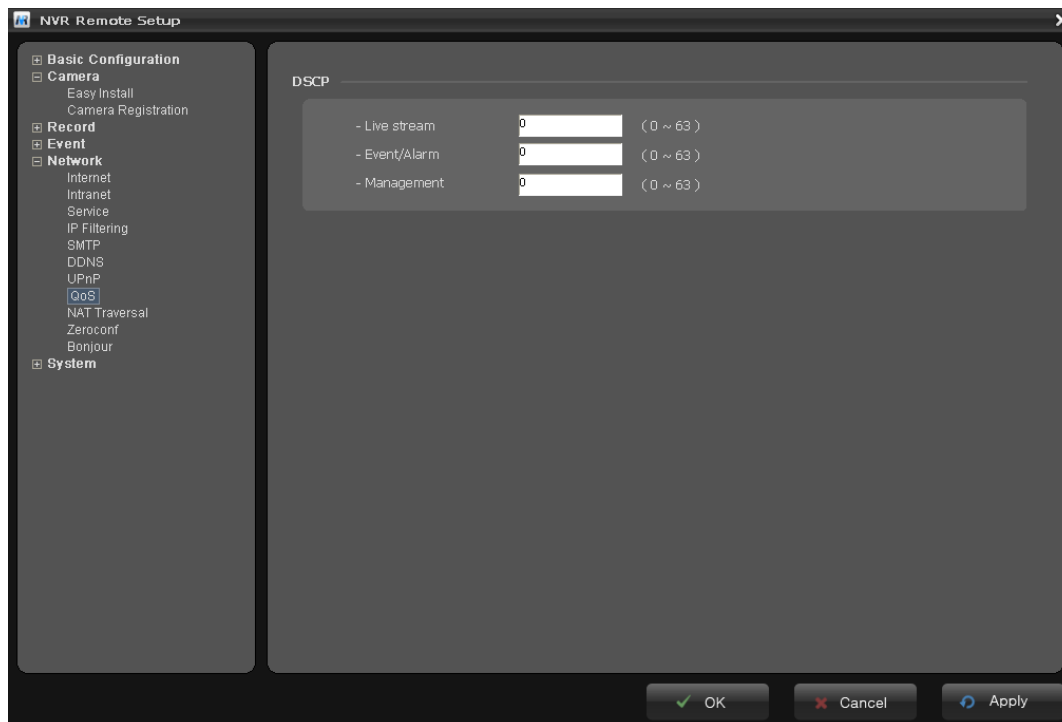

The main benefits of a QoS-aware network are:

- The ability to prioritize traffic and thus allow critical flows to be served before flows with lesser priority.
- Greater reliability in the network, thanks to the control of the amount of bandwidth an application may use, and thus control over bandwidth races between applications.

- **DSCP Settings**

For each type of network traffic supported by your network video product, enter a DSCP (Differentiated Services Code Point) value. This value is used to mark the traffic's IP header. When the marked traffic reaches a network router or switch, the DSCP value in the IP header tell the router or switch which type of treatment to apply to this type of traffic, for example, how much bandwidth to reserve for it. Note that DSCP values can be entered in decimal or hex form, but saved values are always shown in decimal.

The following types of traffic are marked:

- **Live Stream DSCP:**
- **Event/Alarm DSCP:**
- **Management DSCP:**

## 9) NAT Traversal

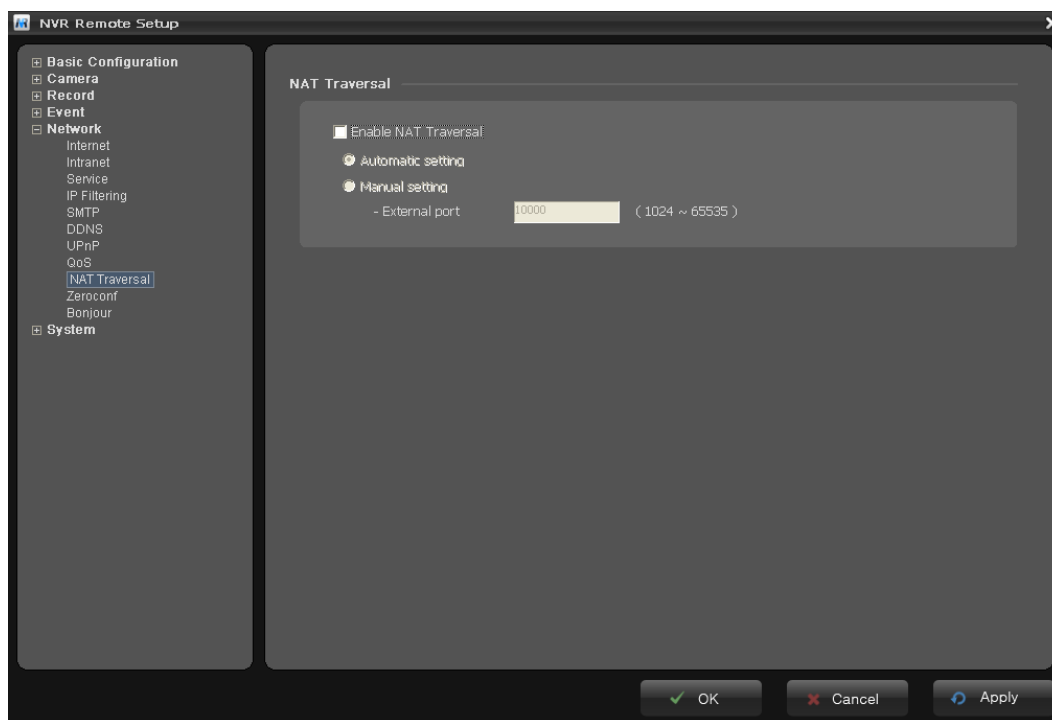

A broadband router allows devices on a private network (LAN) to share a single connection to the Internet. This is done by forwarding network traffic from the private network to the “outside”, that is, the Internet. Security on the private network (LAN) is increased since most broadband routers are pre-configured to stop attempts to access the private network (LAN) from the public network/Internet.

Use **NAT traversal** when your NVR is located on an intranet (LAN) and you wish to make it available from the other (WAN) side of a NAT router. With NAT traversal properly configured, all HTTP traffic to an external HTTP port in the NAT router is forwarded to the NVR.

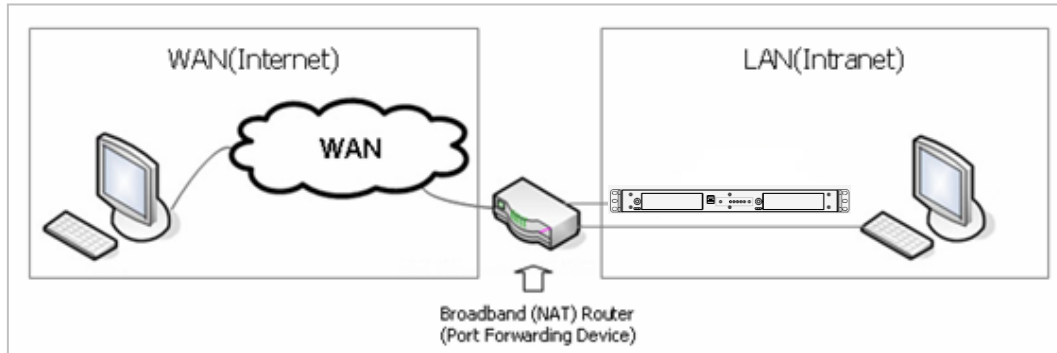

## Notes:

- For NAT traversal to work, this must be supported by the broadband router.
- The broadband router has many different names: "NAT router", "Network router", "Internet Gateway", "Broadband sharing device" or "Home firewall" but the essential purpose of the device is the same.
- **NAT traversal Settings**
  - **Enable** - when enabled, the NVR attempt to configure port mapping in a NAT router on your network, using UPnP™.  
Note that UPnP™ must be enabled in the NVR (see System>Network>UPnP).
  - \* **Automatic setting:** The NVR automatically search for NAT routers on your network.
  - \* **Manual setting:** Select this option to manually select a NAT router and enter the external port number for the router in the field provided.

## Notes:

- If you attempt to manually enter a port that is already in use, an alert message will be displayed.
- When the port is selected automatically it is displayed in this field. To change this enter a new port number and click Save.

## 10) Zeroconfig

Zeroconfig allows the NVR to create and assign IP address for network cameras and connect to a network automatically.

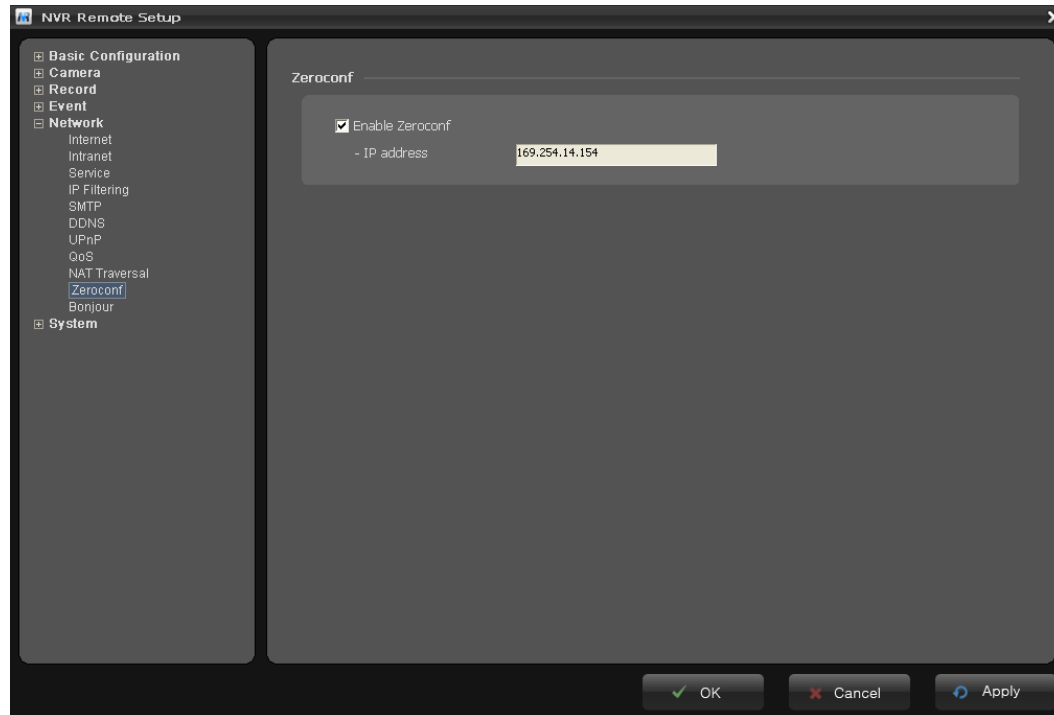

Zero configuration networking (zeroconf), is a set of techniques that automatically creates a usable Internet Protocol (IP) network without manual operator intervention or special configuration servers.

Zero configuration networking allows devices such as computers and printers to connect to a network automatically. Without zeroconf, a network administrator must set up services, such as Dynamic Host Configuration Protocol (DHCP) and Domain Name System (DNS), or configure each computer's network settings manually, which may be difficult and time-consuming.

Zeroconf is built on three core technologies:

- Assignment of numeric network addresses for networked devices (link-local address auto configuration)
- Automatic resolution and distribution of computer hostnames (multicast DNS)
- Automatic location of network services, such as printing devices through DNS service discovery.

**Note:** In case that the network devices connected to the NVR have not IP addresses, Zeroconfig must be enabled to allow IP addresses by the Easy Install function.

## 11) Bonjour

The NVR includes support for Bonjour. When enabled, the NVR is automatically detected by operating systems and clients that support this protocol.

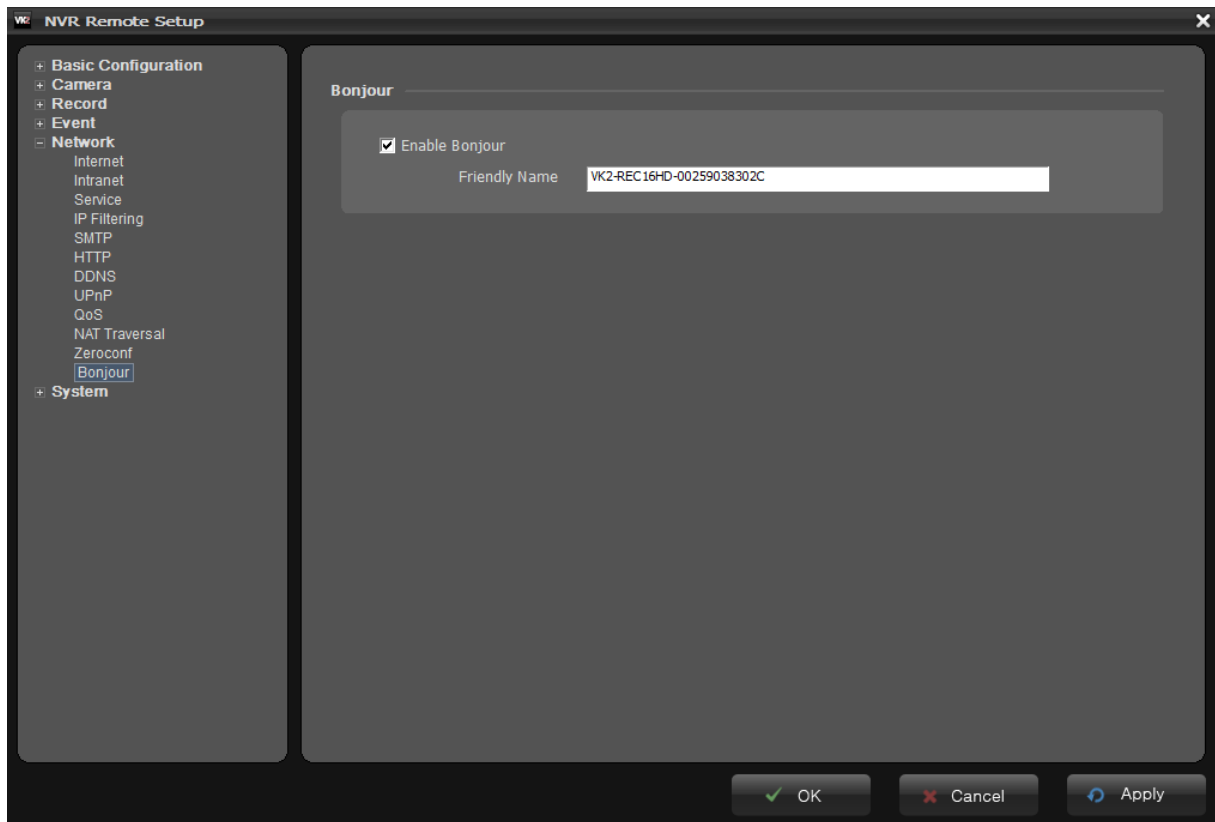

**Note:** Bonjour - Also known as zero-configuration networking, Bonjour enables devices to automatically discover each other on a network, without having to enter IP addresses or configure DNS servers. Bonjour is a trademark of Apple Computer, Inc.

## 3.1.6 System

### 1) Information

You can name the Device Name for the NVR. This page is very useful when you refer device information after installation.

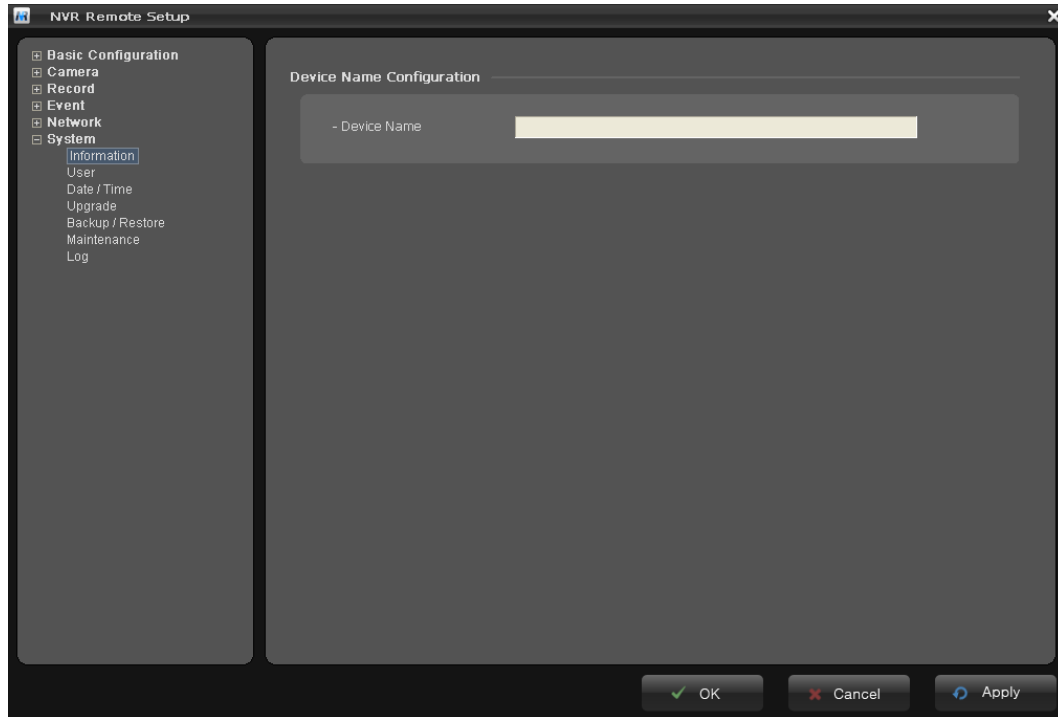

### 2) User

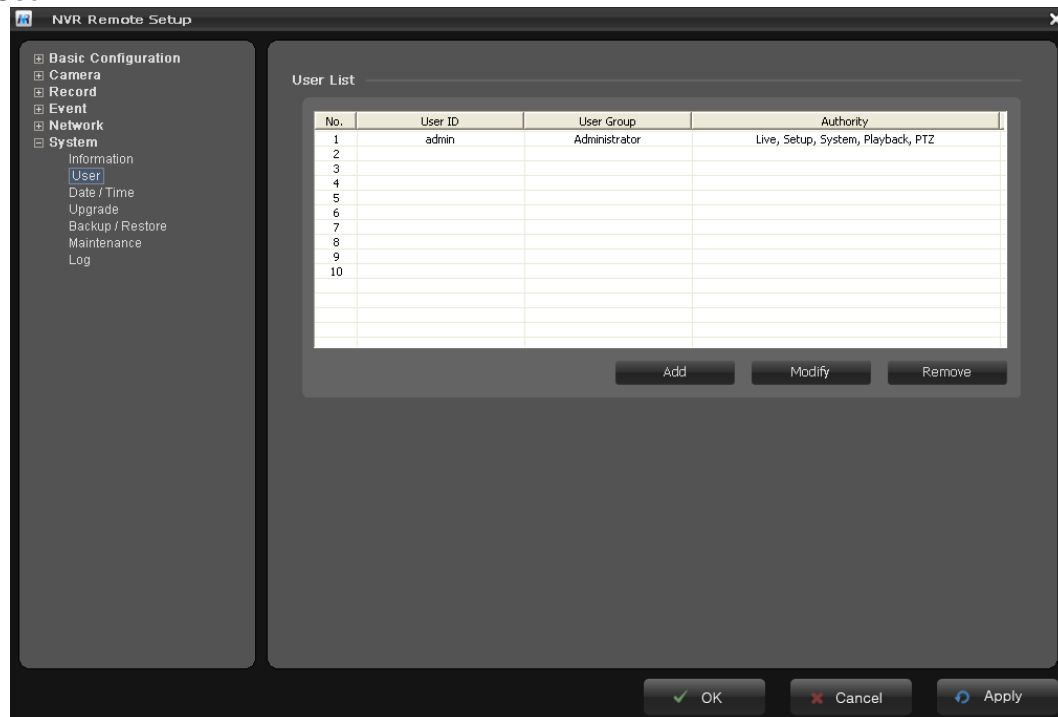

Refer to "User of Chapter 3.1.1".

## 3) Date/Time

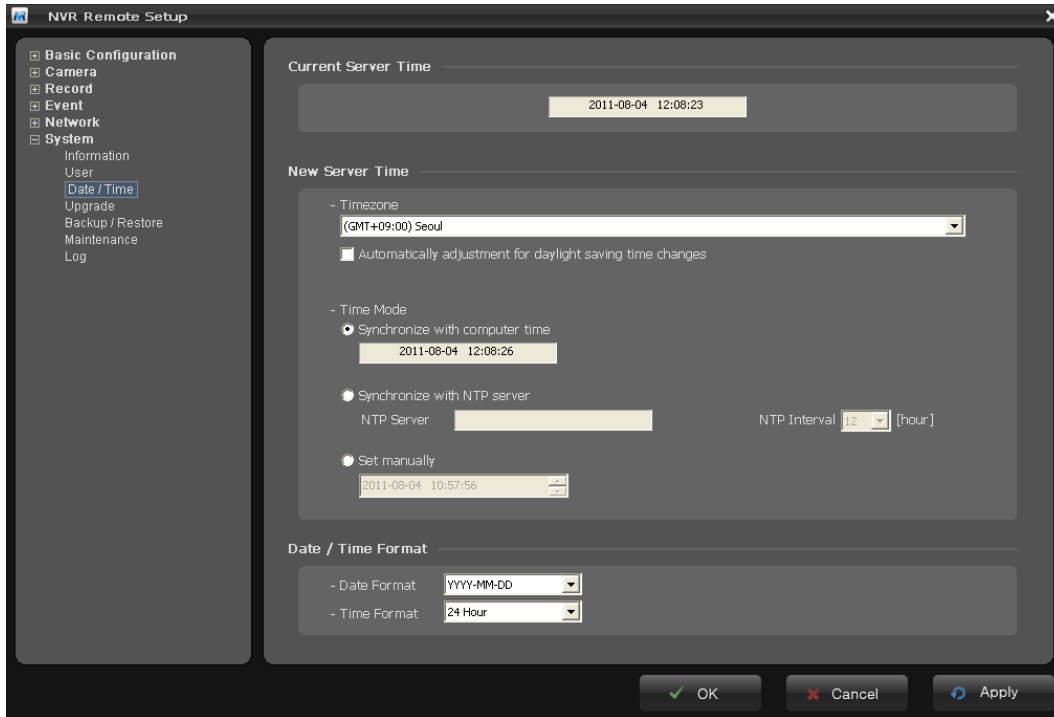

Refer to "Date/Time of Chapter 3.1.1".

## 4) Upgrade

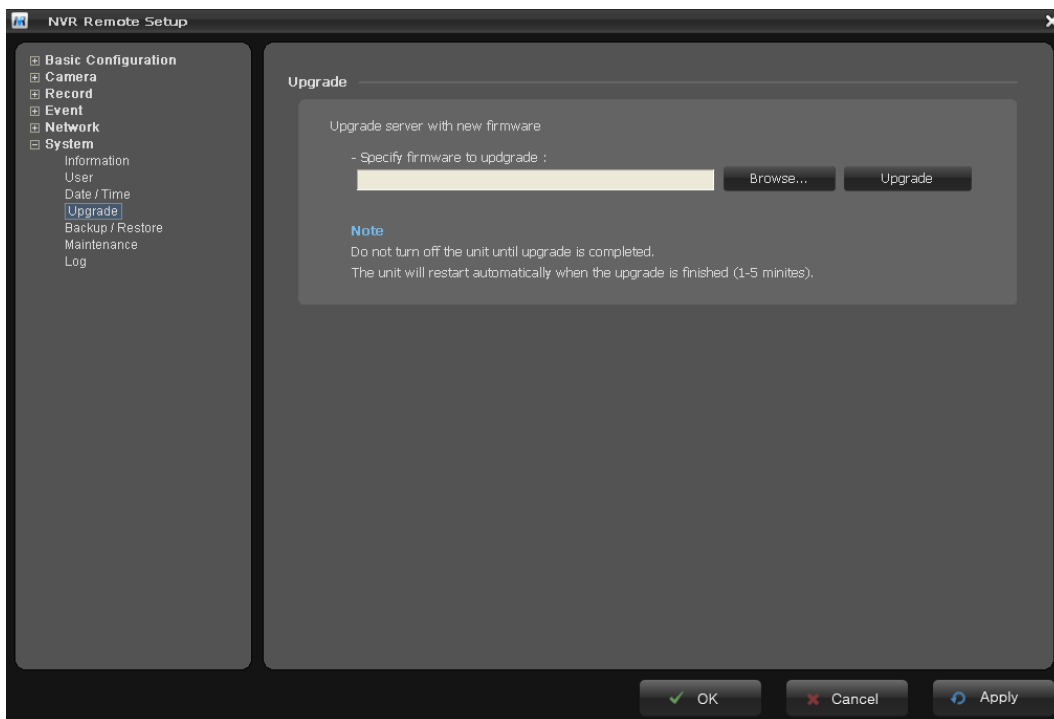



Carry out the upgrade by importing an upgrade file and pressing the Upgrade button. During the upgrade, do not turn off the power of the NVR. And try an access again after waiting five minutes or longer.

## 5) Backup/Restore

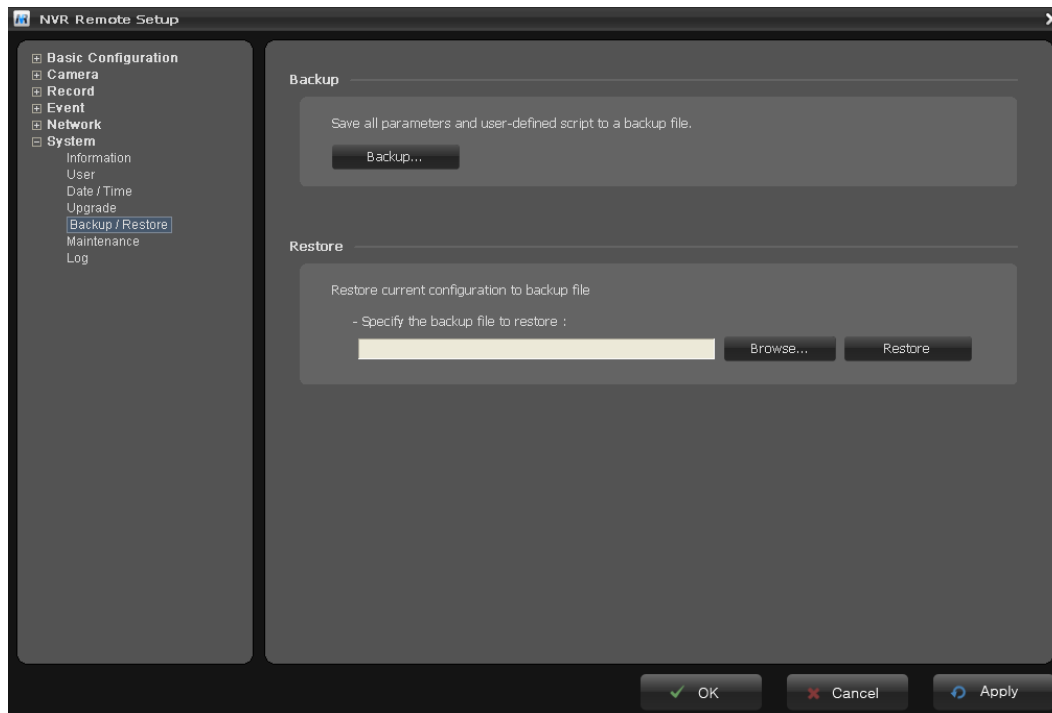

- **Backup**  
Save a setting value that users enter to the NVR, to a user PC.
- **Restore**  
Import and apply a setting value saved to a user PC.

**Note:** Backup and Restore can only be used on the same unit running the same firmware. This feature is not intended for multi-configurations or for firmware upgrades.

## 6) Maintenance

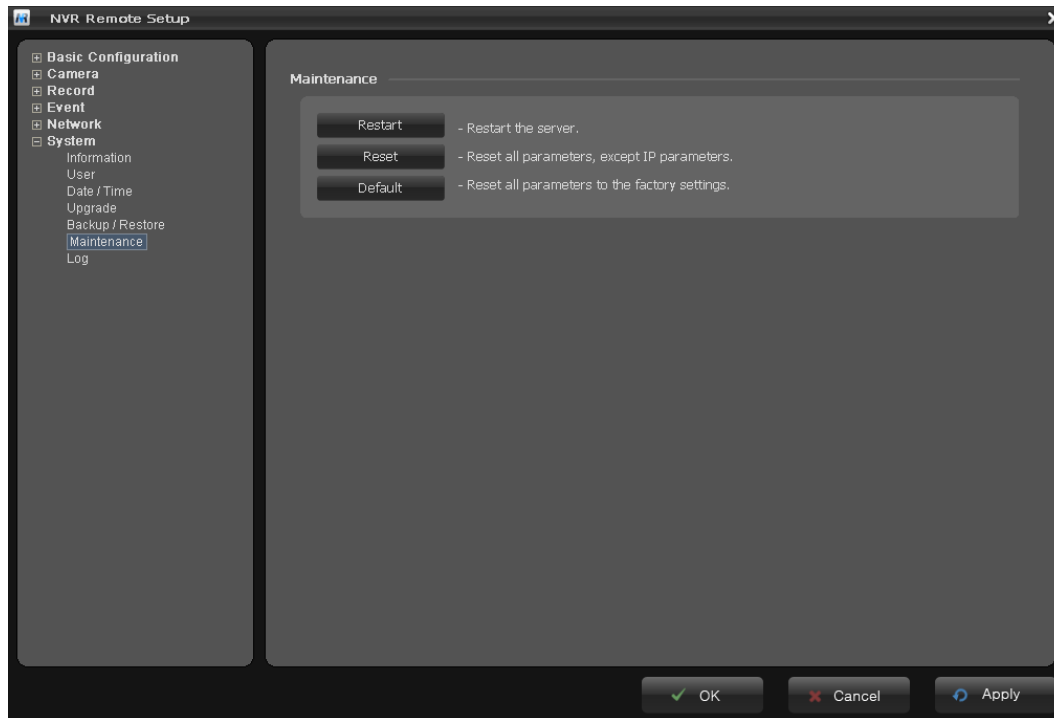

- **Maintenance**

- **Restart:**

- The system is restarted without changing any of the settings. Use this method if the unit is not behaving as expected.

- **Reset:**

- The unit is restarted and most current settings are reset to factory default values. The settings that are not affected are:

- \* the boot protocol (DHCP or static)
    - \* the static IP address
    - \* the default router
    - \* the subnet mask

- **Default:**

- The default button should be used with caution. Pressing this will return all of the NVR's settings to the factory default values (including the IP address).

## 6) Log

The support page provides valuable information on troubleshooting and contact information, should you require technical assistance.

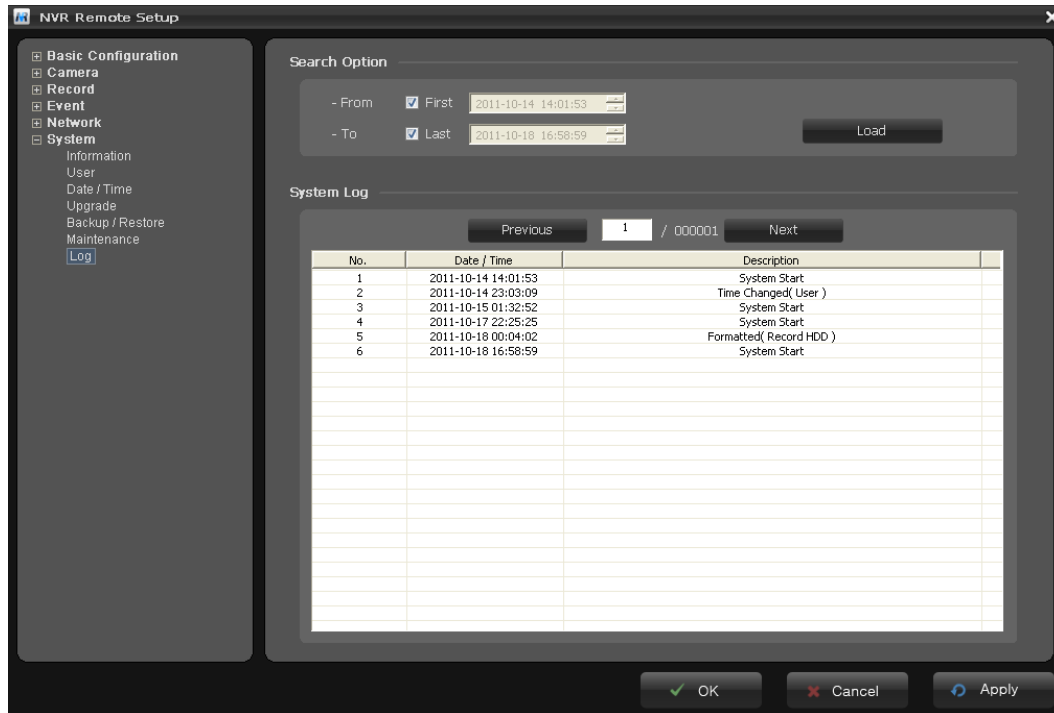

- **Logs**

The network Camera support system log information. Click the System Log button to get the log data.

You can search log from the first to last system logs, or you can set the start and stop times and dates. Click the Load button to start searching.

24 logs are displayed per page and you can scroll through the log pages by using the Previous and Next button. A maximum entry of 10,000 logs can be recorded.

## 4. Operation

### 4.1 Live Monitoring

The Client Live View provides a remote monitoring function for video images in real time from either a single site or multiple sites. In addition, when events are detected at a remote site, the Client Live View displays the event information, and allows users to access the remote site directly to search the image associated with the event.

Select “Live” tab on main window of the Client s/w. You can see the camera list currently registered. Select NVR or Camera in the list and right-click of mouse. The pop-up menu appears as below.

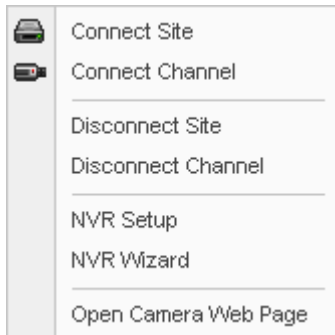

The description of each field follows.

**Connect Site:** Connects all cameras currently registered.

**Connect Channel:** Connects a channel selected.

**Disconnect Site:** Disconnects all cameras currently connected.

**Disconnect Channel:** Disconnects a channel selected.

**NVR Setup:** Set the configuration of NVR.

**NVR Wizard:** Display the pop-up window for Wizard setup.

**Open Camera Web Page:** Display Web page of the network camera selected.

Note: The NVR allows you to access directly in your PC the network camera connected to the local network of the NVR because it has routing function.

Select “Connect Site” in the pop-up menu and check whether the client s/w displays camera videos on the screen. If you can't see camera videos, check the camera information in the Camera Registration menu.

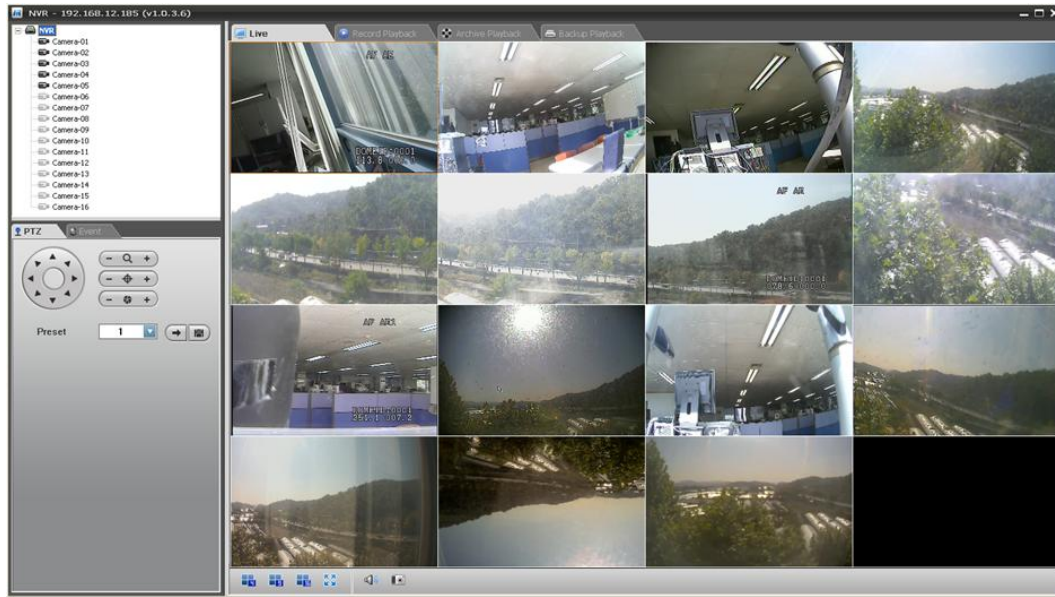

## 4.1.1. Screen Division

You can select the number of video feeds to simultaneously display on-screen by clicking the Screen Division button in the lower left of the screen. You can have 1, 4, 9, 16 channel video feed(s) displayed simultaneously on-screen.

- Screen Division buttons:

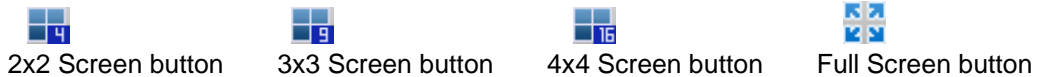

## 4.1.2 Audio Control

The NVR displays mute button, instead audio button, . Pressing the button toggles the mute between on and off

## 4.1.3 PTZ Control

Click on a channel displayed on-screen; a blue border appears around that channel to indicate that the channel has been selected. With a channel selected, you can use the button on the left side of the page to control the PTZ (pan, tilt, zoom) of the camera for the selected channel.

- PTZ Control buttons:

- Direction button:

Change the direction that the camera faces. Click a direction on the circular button to pan the camera in that direction.



- Zoom button:

Adjust the zoom of a selected camera. Click “+” and “-” to zoom in and out.



- Focus button:

Adjust the focus of a selected camera. Click “+” and “-” to adjust the focus.





- IRIS button:

Adjust the iris of a selected camera. Click “+” and “-” to adjust the iris.



- Preset button:

Set the preset position for the PTZ camera. Select “Number” to set preset number and click the button  to save a current video position. Select “Number” and click the  button to move the PTZ camera to preset position.





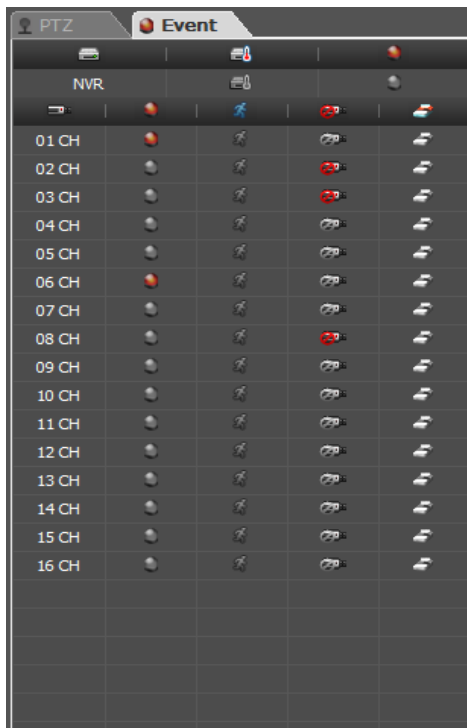

## 4.1.4 Event Status Screen

You can monitor live video from a camera where an event is detected. The event list on the left side display live events detected at the network video device. The live events are listed only during live monitoring. Click the Event tab, and the Event Status screen appears.



- Event status icons:

Display the status of event such as Alarm-In, Motion, and Video Loss from each came and Alarm-In and System Event by NVR itself.

-  Alarm In, displays the detection of an alarm input.
-  Motion, displays the detection of a motion event
-  Video Loss, displays the detection of network fail from camera.
-  Text-In, displays the detection of text-in data.
-  System Event, displays the detection of HDD high temperature.

## 4.2 Record Playback

Select “Record Playback” tab on main window of the Client s/w. You can see the camera list currently registered. Select NVR or Camera in the list and right-click of mouse. The pop-up menu appears as below.

Select “Connect Site” in the pop-up menu. You can see the camera videos recorded in the NVR.

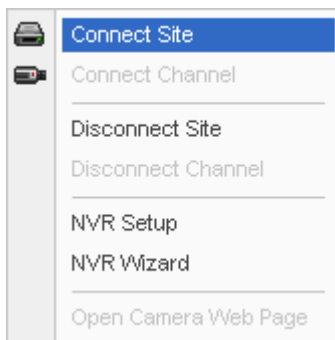

There are two ways to use the Playback option; Time-Lapse Search enables you to search and watch videos by the recorded time and date, while Event Search lets you view videos according to events that have occurred. When connecting to the Playback screen for the first time, the Time-Lapse Search menu appears as the default.

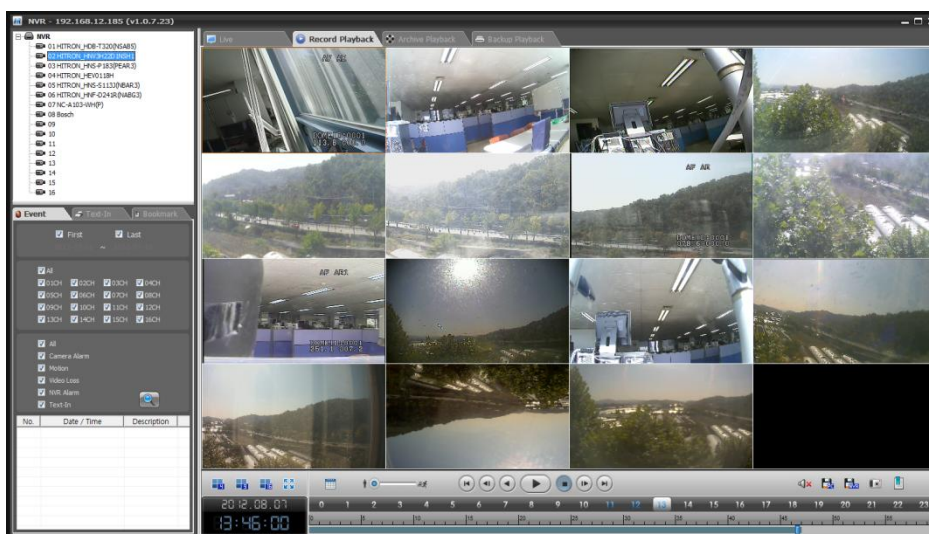

## 4.2.1 Time-Lapse Search

In the calendar, if you succeed with a connection with the remote site and there is a recorded data for a particular date, a blue square on the date will be displayed. Selecting a blue date by clicking the mouse displays an hour-based search screen for the chosen date.



**Note:** Click the “Calendar” icon to see calendar window

If there is data for a channel, a white section will be displayed on a 24-hour based time chart.

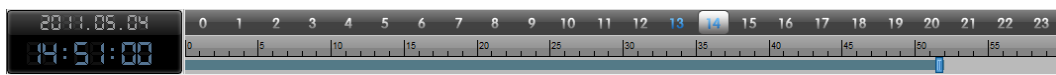

Go to a specific hour by clicking the mouse on the desired hour segment. A minute-based search window is as below. If there is data for a channel, a blue section will be displayed on a 60-minute basis.

Go to a specific minute by clicking the mouse on the desired minute segment. Video images will be played back starting with the first image captured within the one-hour segment.

If you drag the slide bar in the time chart, you can play video image by 1 minute unit very conveniently.

- **General Controls**

The descriptions of each button used for the playback operation are as follows.

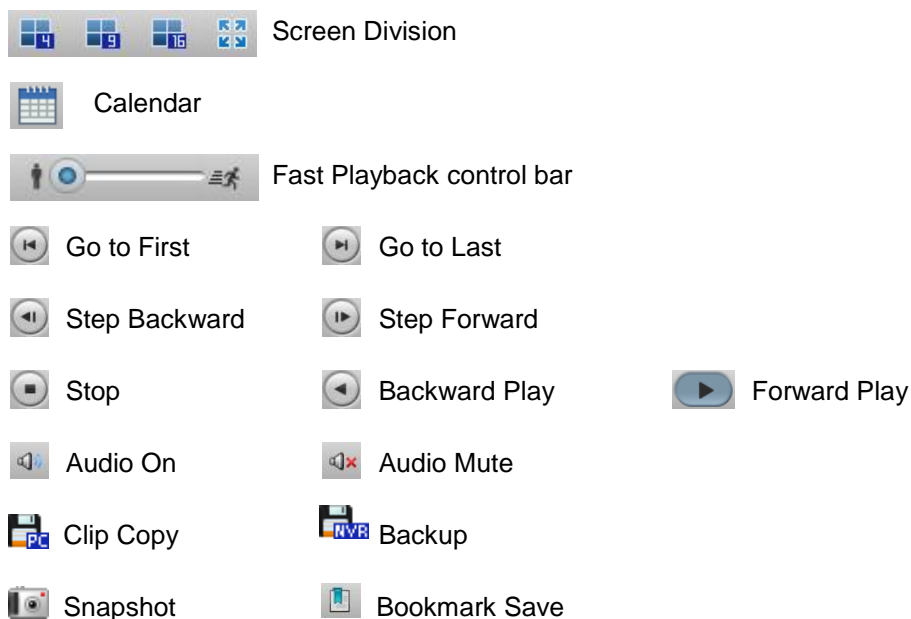



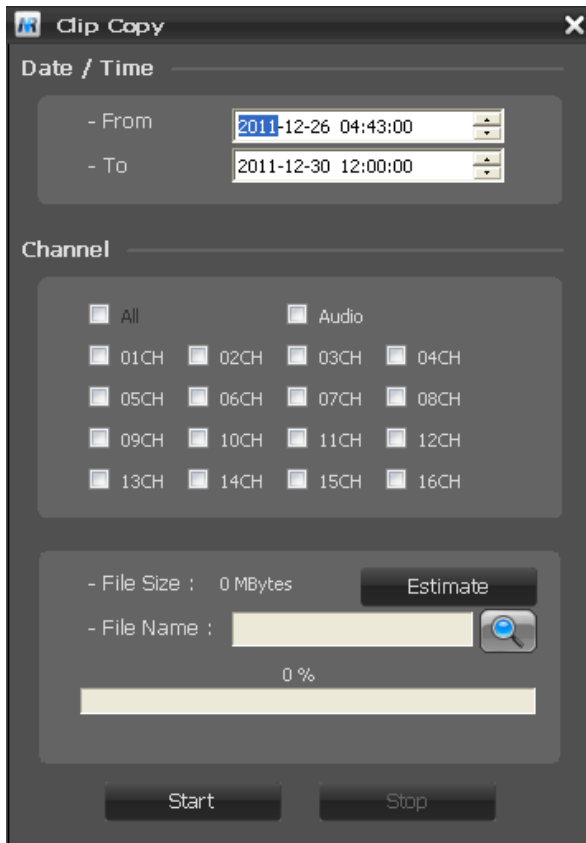

- **Clip Copy**

Click the  button to start the clip-copy. Clip-Copy allows the NVR to clip a video segment already stored in the storage and save it to your remote PC. The clip-copy setup screen appears.



Change the Days and Time range, the Channel you want to clip and press the Estimate button to calculate the size of the data to be copied. The size is displayed in the File Size field. Click the  button to enter the name and location of the file to be copied and press the Start button. The progress bar will be displayed.

- **Backup**

Click the  button to start the backup. Backup allows the NVR to clip a video segment already stored in the storage and save it to the external storage. The backup screen appears.

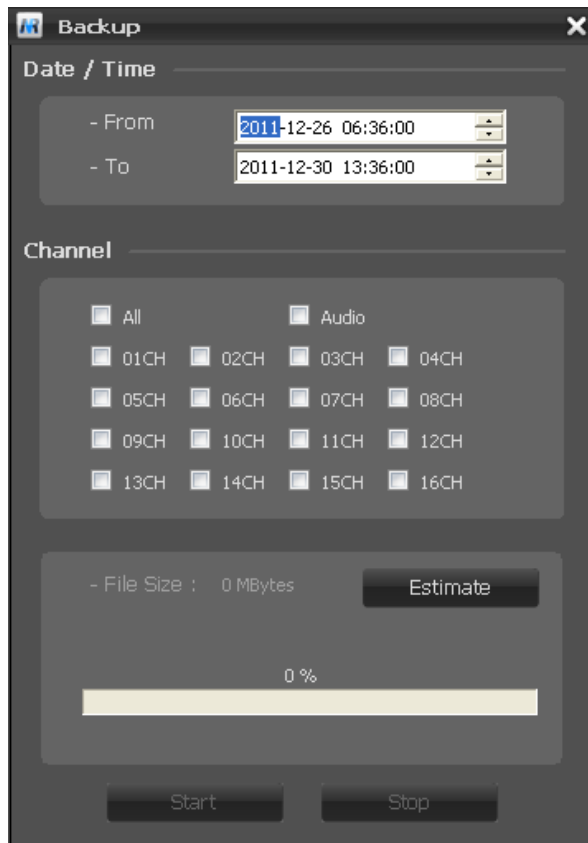

Change the Days and Time range, the Channel you want to clip and press the Estimate button to calculate the size of the data to be copied. The size is displayed in the File Size field. Click the  button to enter the name and location of the file to be copied and press the Start button. The progress bar will be displayed.

- **Snapshot**

The NVR allows you to capture an image on playing. Click the  button to capture a playing image.

- **Bookmark Save**

The NVR allows you to mark the important date and time on playing. Click the  button to save bookmark.

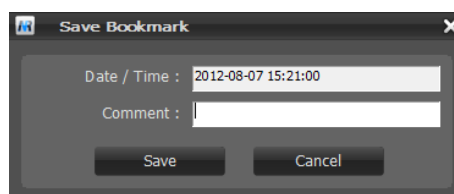

## 4.2.2 Event Search

The event search screen is located on the left side Record Playback window.

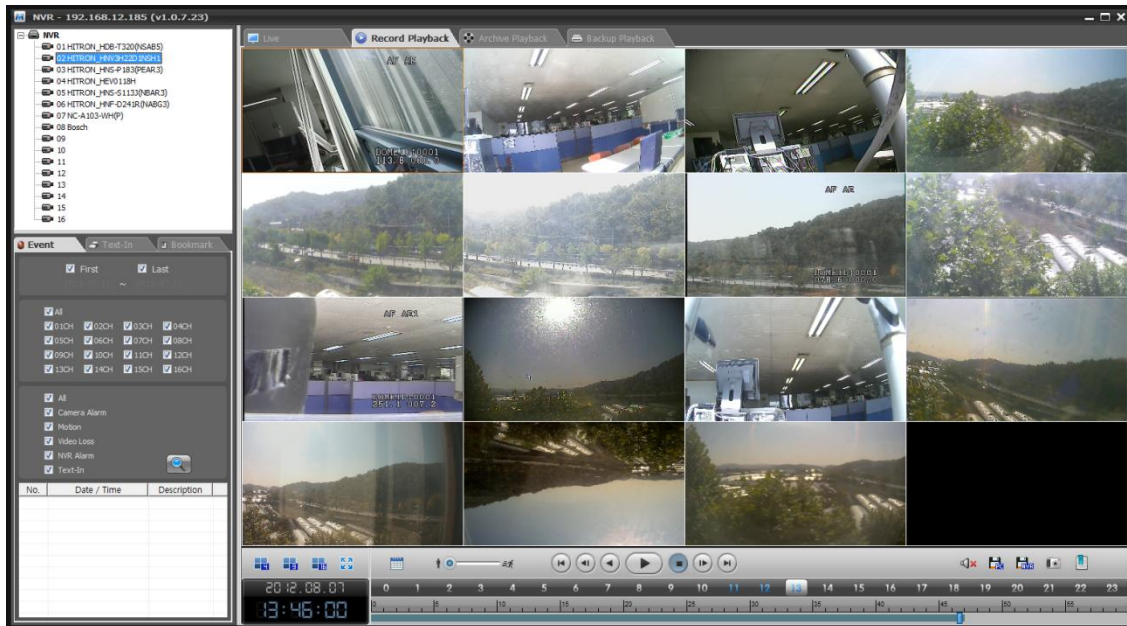

The NVR maintains a log of each time the Alarm Input port is activated. The Event Log Search screen displays this list. You can select the event for which you would like to see video.

You can search video from the first to last recorded images, or you can set the start and stop times and dates.

Inactivating the First and Last box will allow the user to manually change the time to be searched.

Select the box beside of the cameras you want to search. You can select the events for which you want to search. Once you set your desired search conditions, select the  button to display the search results.

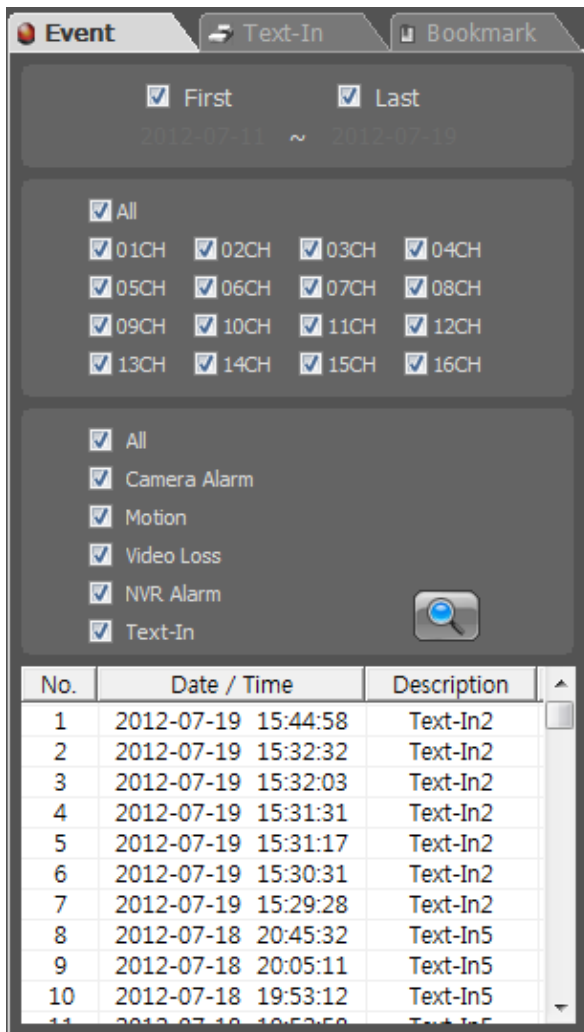

Clicking an event for which you would like to see video. The NVR will extract the event video and display the first image of the event. Pressing the PLAY, ► button will start playing the “event” video segment.

### 4.2.3 Text-In Search

The NVR maintains a log of each time the text-in data is detected. The Text-In Search screen displays this list. You can select the event for which you would like to see video.

You can search video from the first to last recorded images, or you can set the start and stop times and dates.

Deactivating the First and Last box will allow the user to manually change the time to be searched. Select the box beside of the cameras you want to search. Once you set your desired search conditions, select the  button to load option dialog box and display the search results. Refer to “Appendix 5.6 Text-In Search” for more information.

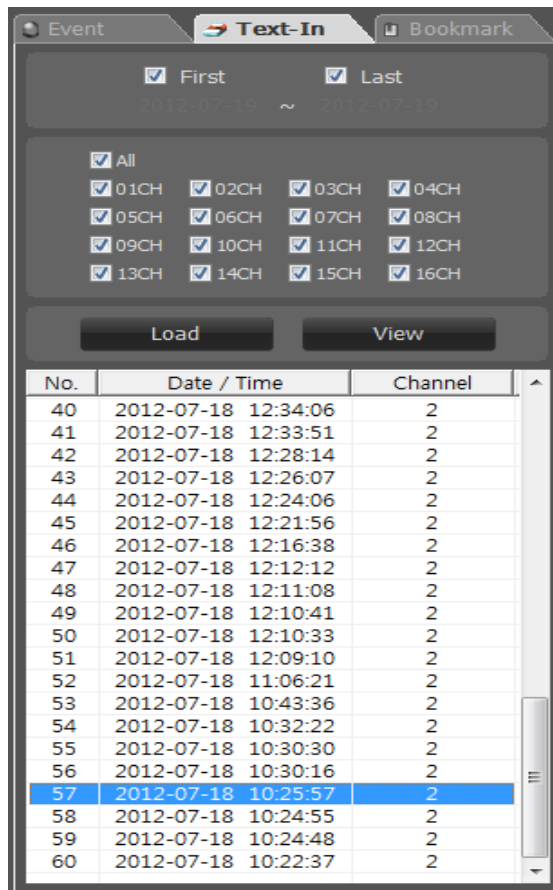

Clicking an event list for which you would like to see video. The NVR will extract the event video and display the first image of the event. Pressing the PLAY, ► button will start playing the “text-in” video segment.

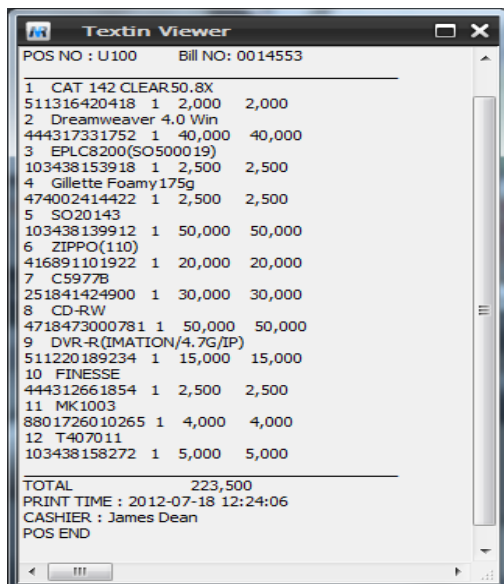

You can see the detail text-in data by clicking  button to show pop-up window as below.

## 4.2.4 Bookmark Search

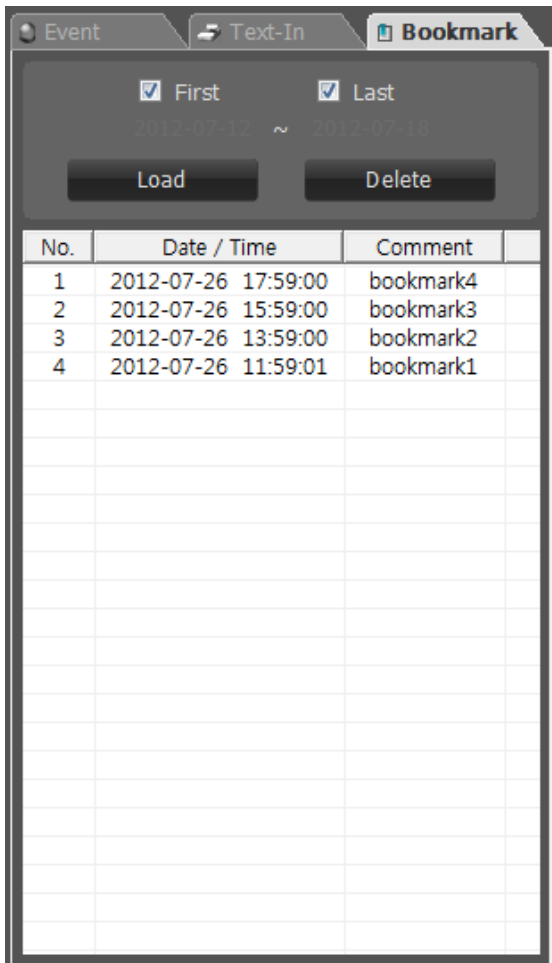

The NVR maintains a log of bookmark data. The Bookmark Search screen displays this list. You can select the bookmark for which you would like to see video.

You can search video from the first to last recorded images, or you can set the start and stop times and dates.

Inactivating the First and Last box will allow the user to manually change the time to be searched.

Once you set your desired search conditions, select the **Load** button to display the search results.

Clicking an bookmark list for which you would like to see video. The NVR will extract the bookmarked video and display it. Pressing the PLAY, ► button will start playing the “bookmarked” video segment.

Select the bookmark item in list and click **Delete** button to delete it.

## 4.3 Archive Playback

Select “Archive Playback” tab on main window of the Client s/w. You can see the camera list currently registered. Select NVR or Camera in the list and right-click of mouse. The pop-up menu appears as below.

Select “Connect Site” in the pop-up menu. You can see the camera videos from archive storage in the NVR.

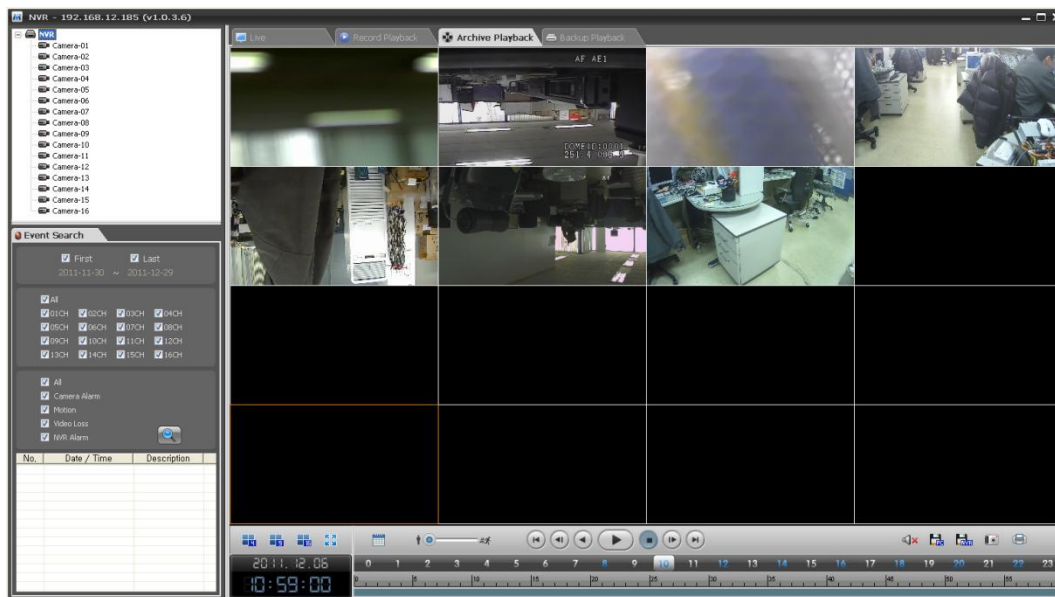
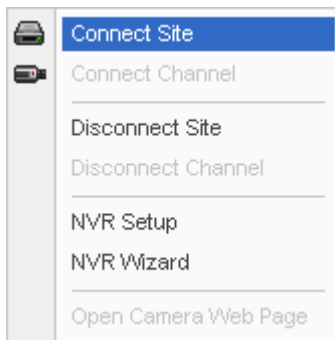

There are four ways to use the Playback option; Time-Lapse Search, Event Search, Text-In Search and Bookmark Search. All functions for Archive Playback are same as Record Playback.

## 4.4 Backup Playback

Select "Backup Playback" tab on main window of the Client s/w. You can see the camera list currently registered. Select NVR or Camera in the list and right-click of mouse. The pop-up menu appears as below.

Select "Connect Site" in the pop-up menu. You can see the camera videos from the external USB storage connected as a backup device to the NVR.

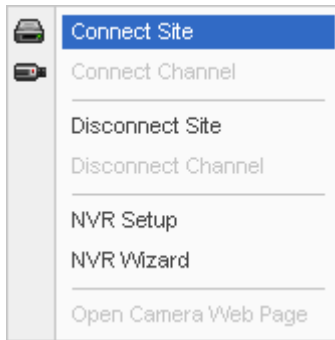

All functions for Archive Playback are same as Record Playback except for backup function.

**Caution:** For a proper operation, check if the external USB storage is connected to the NVR.



## 5. Appendix

### 5.1 Troubleshooting

Troubleshooting if problems occur, verify the installation of the NVR with the instructions in this manual and with other operating equipment. Isolate the problem to the specific piece of equipment in the system and refer to the equipment manual for further information.

Problems/Symptoms	Possible Causes or Corrective Actions
The NVR cannot start or boot.	<ul style="list-style-type: none"> <li>▪ Check AC power and power cord.</li> </ul>
The NVR is powered up but do not respond any operation.	<ul style="list-style-type: none"> <li>▪ Turn the main power off and wait for 5 seconds. The LED indicator on the front panel should be turned off.</li> <li>▪ Turn the main power on again.</li> </ul>
The camera cannot be accessed from the NVR.	<ul style="list-style-type: none"> <li>▪ Check all cabling and local network port connection.</li> <li>▪ Check NVR network settings.</li> <li>▪ Run ping test for IP camera in the local network.</li> </ul>
The camera works locally, but cannot be accessed from the NVR.	<ul style="list-style-type: none"> <li>▪ Check all cabling and internet network port connection.</li> <li>▪ Check if there are firewall settings that need to be adjusted.</li> <li>▪ Check if there are router settings that need to be configured.</li> <li>▪ Check NVR network settings.</li> <li>▪ Check PC network settings.</li> <li>▪ Run ping test for the NVR's IP in the internet network.</li> </ul>
The camera web viewer cannot be accessed through internet port of the NVR from PC.	<ul style="list-style-type: none"> <li>▪ Check NVR setting on network routing.</li> <li>▪ Check PC network settings.</li> <li>▪ Run ping test for the camera's IP in the internet network.</li> </ul>
Poor or intermittent network connection.	<ul style="list-style-type: none"> <li>▪ If using a network switch, check that the port on that device uses the same setting for the network connection type (speed/duplex).</li> </ul>
The NVR has stopped recording	<ul style="list-style-type: none"> <li>▪ If hard disk drive is full, you will either need to delete video or set the system to the Overwrite Mode.</li> <li>▪ Check recording schedule settings.</li> </ul>
Not possible to log in.	<ul style="list-style-type: none"> <li>▪ When HTTPS is enabled, ensure that the correct protocol (HTTP or HTTPS) is used. When attempting to log in, you may need to manually type in http or https in the browser's address bar.</li> </ul>
Poor image quality.	<ul style="list-style-type: none"> <li>▪ Check camera settings.</li> </ul>
If you are experiencing any of the following issues, you must stop using the product and turn the power off immediately, then contact Vista for assistance.	<ul style="list-style-type: none"> <li>▪ Product is behaving strangely (example: unusual noises, smells, or smoke is coming from the product.)</li> <li>▪ The power cable connector has been damaged.</li> <li>▪ Rain or other liquid has entered the product.</li> <li>▪ You have spilled liquid into the product, or foreign material has entered the product.</li> <li>▪ The product does not work as specified in this instruction manual.</li> <li>▪ The product has been dropped and severely damaged.</li> <li>▪ There is a noticeable degradation in the performance of the product.</li> </ul>

## 5.2 Comprehension about Archive and BACKUP function

		ARCHIVE	BACKUP
Description		Records a video to the internal storage and copies it to the external storage at the same time.	Clips a video segment already stored in the storage and saves it to the external storage.
Available Media		eSATA HDD	USB CD-RW/USB DVD-RW USB STICK USB HDD
Playback	Windows	○	○
	NVR	○	○

## 5.3 Alarm Connection

The following connection diagram gives an example of how to connect alarm input and output to the NVR.

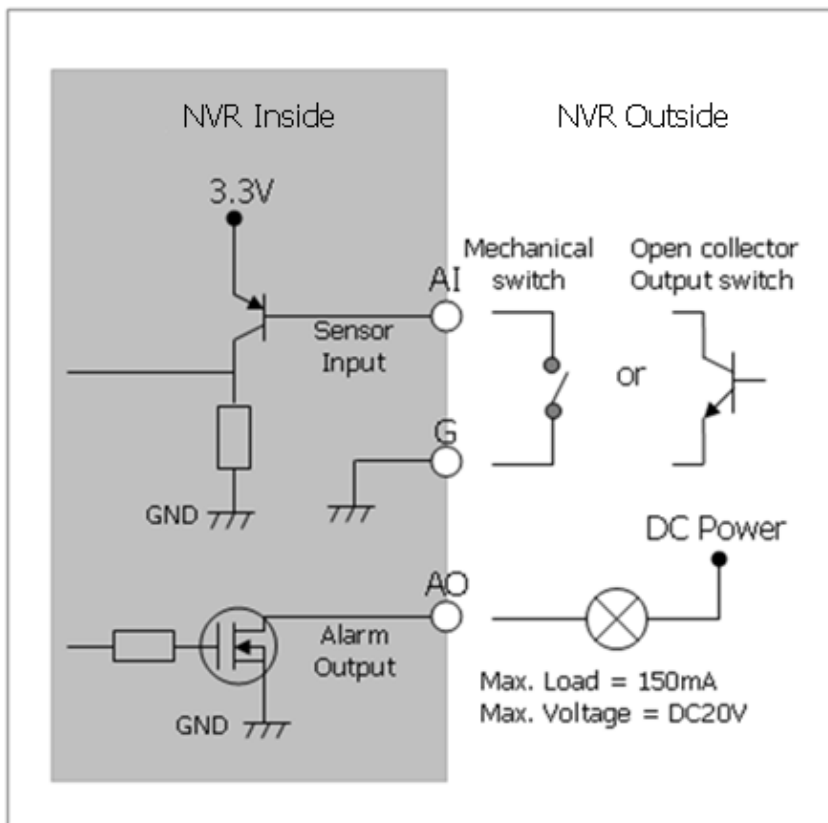

## 5.4 Preventive Maintenance

Preventive maintenance allows detection and correction of minor that faults before they become serious and cause equipment failure.

Every three-month, perform the following maintenance.

1. Inspect all connection cables for deterioration or other damage.
2. Clean components with a clean damp cloth.
3. Verify that all the mounting hardware is secure.

## 5.5 Product Specification

Specification		VK2-REC16HD
<b>Video</b>	IP Camera Input	16
	Supported Cameras	Vista VK2 Cameras
	Supported Video Format	H.264, MPEG-4, MJPEG
	Supported Video Resolution	320x240 ~ 1920x1080
<b>Recording</b>	Recording Mode	Schedule, Text-In, Event
	Pre-Alarm Recording	Up to 15 Seconds
	Frame Rate (NTSC)	Max 480fps @ 16ch x1920 x 1080, 4Mbits
	Frame Rate (PAL)	Max 400fps @ 16ch x1920 x 1080, 4Mbits
<b>Search &amp; Playback</b>	Search Mode	Calendar, Time, Event, Text-In, Bookmark
	Playback Control	PLAY, Rev PLAY, Pause, Stop, FF, FR, Step Forward, Step Backward, Goto First, Goto Last
<b>Network</b>	Bandwidth Control	Automatic
	No. of simultaneous users	3
	Supported Protocol	TCP/IP, UDP, IPv4/v6, HTTP, HTTPS, QoS, FTP, SNMP, uPnP, RTP, RTSP, RTCP, DHCP, ARP, Zeroconfig, Bonjour
	User Registration	20
	Monitoring	VK2 Client Software, Built-in web browser
<b>Storage</b>	Internal HDD	Up to 4 SATA
	External HDD	Expansion by 1 eSATA port
<b>Input/Output</b>	Alarm	Terminal TTL 2 Input, Terminal TTL 2 Output
	Ethernet	2 x 100/1000 Base-T
	USB	2 x USB2.0 (Front), 2 x USB2.0 (Rear)
	eSATA	1 External SATA port
<b>Electrical</b>	Power Source	100 - 240 V AC ±10%, 50/60 Hz
	Power Consumption	550mA (70W)
<b>Environment</b>	Operating Temperature	0°C ~ +45°C (+36°F ~ +114°F)
	Humidity	0%RH ~ 60%RH
<b>Mechanical</b>	Dimension (W x H x D) mm unit	435 x 89 x 425.6 (without rack mount) 6.9kg, Without HDD
	Weight	

## System Requirement for Web Browser

Operating System: Microsoft Windows 7 pro, Microsoft Windows 8 Pro.

CPU: Intel® Core™ i7-920 or faster, RAM: 3 GB or more, VRAM: 128 MB or more (Min. 64 MB), Microsoft® DirectX® 9.0c or later

## 5.6 Text-In Search

1234567890123456789012345678901234567890123456789012345678901234567890

Item	Price	Qty	amount
Gillette Foamy	\$ 10.1	1	\$ 10.1
CD-RW	\$ 5.1	1	\$ 5.1
Coke	\$ 2.2	2	\$ 4.4

In the above text-in data, you can find that the comparison value is located at 21<sup>th</sup> (Price), 33<sup>th</sup>(Qty), and 45<sup>th</sup>(amount) characters (including spaces) from the left. In this case, you can enter “21”, “33” and “45” in each column box. For example, if you want to search for Gillete with a Price over \$10 and CD-RW with an Qty of more than 1, the following search condition can be set.

Use	Name	Compare	Value	Column	Line
O	Gillette	>=	10	21	0
O	CD-RW	>=	1	33	0
X		=		0	0
X		=		0	0
X		=		0	0