

# Multibeam 2

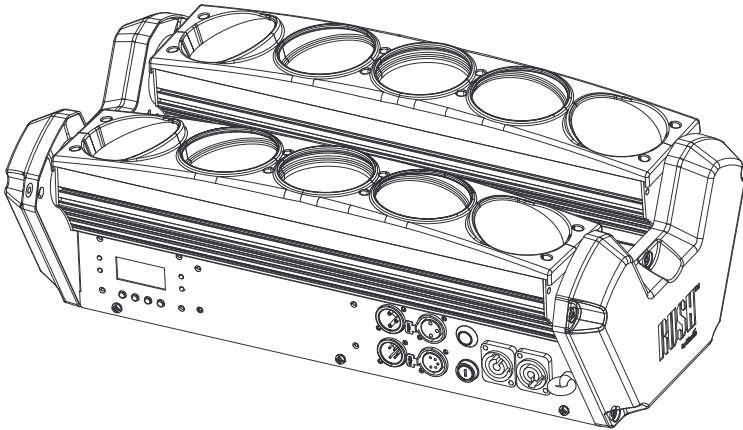

## User Manual



Professional Entertainment Technology

© 2013-2014 Martin Professional . Information subject to change without notice. Martin Professional and all affiliated companies disclaim liability for any injury, damage, direct or indirect loss, consequential or economic loss or any other loss occasioned by the use of, inability to use or reliance on the information contained in this manual. The Martin logo, the RUSH by Martin logo, the RUSH by Martin name, the Martin name and all other trademarks in this document pertaining to services or products by Martin Professional or its affiliates and subsidiaries are trademarks owned or licensed by Martin Professional or its affiliates or subsidiaries.

Martin Professional • Olof Palmes Allé 18 • 8200 Aarhus N • Denmark • [www.martin.com](http://www.martin.com)

**Manual: Revision B**

# Table of contents

Safety information .....	4
Introduction .....	8
Before using the product for the first time .....	8
Physical installation .....	9
Fastening the fixture to a flat surface .....	9
Mounting the fixture on a truss .....	9
Securing with a safety cable .....	10
AC power .....	11
Linking fixtures to power in a chain .....	12
Fixture overview .....	12
Control data link .....	14
Tips for reliable data transmission .....	14
Connecting the DMX data link .....	14
Fixture setup .....	15
Using the control menus .....	15
DMX function settings .....	15
Show settings .....	16
Fixture settings .....	18
Fixture test .....	18
Fixture information .....	19
Reset functions and settings .....	19
Effects .....	19
Tilt movement .....	19
Strobe effects .....	20
Electronic dimming .....	20
Individual RGBW color control .....	20
Maintenance .....	20
Cleaning .....	20
Fuse replacement .....	21
Service and repairs .....	21
DMX protocol .....	23
Control menus .....	25
Troubleshooting .....	26
Specifications .....	28

# Safety information



## WARNING!

**Read the safety precautions in this manual before installing, powering, operating or servicing this product.**

The following symbols are used to identify important safety information on the product and in this manual:



### Warning!

Safety hazard.  
Risk of severe injury or death.



### Warning!

LED light emission. Risk of eye injury.



### Warning!

Refer to manual before installing, powering or servicing.



### Warning!

Hazardous voltage. Risk of lethal or severe electric shock.



### Warning!

Hot surfaces and fire hazard.



**Risk Group 2 LED product according to EN 62471. Do not view the light output with optical instruments or any device that may concentrate the beam.**

This product is for professional use only. It is not for household use. It product presents risks of severe injury or death due to fire hazards, electric shock and falls.

Respect all locally applicable laws, codes and regulations when installing, powering, operating or servicing the fixture.



Read this manual before installing, powering or servicing the fixture, follow the safety precautions listed below and observe all warnings in this manual and printed on the fixture. Keep this manual for future use. If you have questions about how to operate the fixture safely, please contact your RUSH by Martin™ dealer or call the Martin™ 24-hour service hotline on +45 8740 0000, or in the USA on 1-888-tech-180.

For the latest user documentation and other information about this and all Martin™ products, please visit the Martin website at <http://www.martin.com>



## **Protection from electric shock**

Do not expose the fixture to rain or moisture.

Shut down power to the fixture before carrying out any installation or maintenance work and when the fixture is not in use.

Ensure that the fixture is electrically connected to ground (earth).

Use only a source of AC power that complies with local building and electrical codes and has both overload and ground-fault (earth-fault) protection.

Socket outlets or external power switches used to supply the fixture with power must be located near the fixture and easily accessible so that the fixture can easily be disconnected from power.

Replace defective fuses with ones of the specified type and rating only.

Isolate the fixture from power immediately if the power plug or any seal, cover, cable, or other component is damaged, defective, deformed, wet or showing signs of overheating. Do not reapply power until repairs have been completed.

Before using the fixture, check that all power distribution equipment and cables are in perfect condition and rated for the current requirements of all connected devices.

Use only Neutrik PowerCon cable connectors to connect to power sockets.

Do not connect devices to power in a chain that will exceed the electrical ratings of any cable or connector used in the chain.

The supplied power input cable is rated 6 A and can safely supply only one fixture with mains power. Do not connect any device to the fixture's MAINS OUT connector when using this cable. If you replace this cable and also use the replacement cable to supply only one fixture with mains power, the replacement cable must also be rated 6 A minimum, have three conductors 18 AWG or 0.75 mm<sup>2</sup> minimum conductor size, have an outer cable diameter of 6 - 15 mm (0.2 - 0.6 in.) and be temperature-rated to suit the application. In the USA and Canada the cable must be UL listed, type SJT or equivalent. In the EU the cable must be type H05VV-F or equivalent.

To connect fixtures to mains power in a chain, you must first

obtain 12 AWG or 2.5 mm<sup>2</sup> power input and throughput cables that are 16 A rated and temperature-rated to suit the application. In the USA and Canada the cables must be UL-listed, type SJT or equivalent. In the EU the cables must be type H05VV-F or equivalent. Suitable cables with Neutrik PowerCon connectors are available from Martin™ (see Accessories on page 29). If you use these cables, you can connect fixtures to power in a linked chain, MAINS OUT throughput socket to MAINS IN input socket, but do not link more than:

- seven (7) RUSH Multibeam 2 fixtures in total at 100-120 V, or
- twelve (12) RUSH Multibeam 2 fixtures in total at 200-240 V.

The voltage and frequency at the MAINS OUT socket are the same as the voltage and frequency applied to the MAINS IN socket. Only connect devices to the MAINS OUT socket that accept this voltage and frequency.



### **Protection from burns and fire**

Do not operate the fixture if the ambient temperature ( $T_a$ ) exceeds 40° C (104° F).

The surface of the product casing can reach up to 85° C (185° F) during operation. Avoid contact by persons and materials. Allow the fixture to cool for at least 15 minutes before handling.

Keep flammable materials well away from the fixture. Keep all combustible materials (e.g. fabric, wood, paper) at least 100 mm (4 in.) away from the lenses on the LED bars.

Ensure that there is free and unobstructed airflow around the fixture. Provide a minimum clearance of 100 mm (4 in.) around air vents.

Do not illuminate surfaces within 200 mm (7.9 ins.) of the fixture.

Do not attempt to bypass thermostatic switches or fuses.

Do not stick filters, masks or other materials onto any optical component.



### **Protection from eye injury**

Do not look at LEDs with magnifiers, telescopes, binoculars or similar optical instruments that may concentrate the light output.



## **Protection from injury**

Fasten the fixture securely to a fixed surface or fixed structure when in use. The fixture is not portable when installed.

Ensure that any supporting structure and/or hardware used can hold at least 10 times the weight of all the devices they support.

If suspending from a rigging structure, fasten the fixture to a rigging clamp. Do not use safety cables as the primary means of support.

If the fixture is installed in a location where it may cause injury or damage if it falls, install as directed in this manual a secondary attachment such as a safety cable that will hold the fixture if a primary attachment fails. The secondary attachment must be approved by an official body such as TÜV as a safety attachment for the weight that it secures, must comply with EN 60598-2-17 Section 17.6.6 and must be capable of bearing a static suspended load that is ten times the weight of the fixture and all installed accessories.

Allow enough clearance around the fixture to ensure that it cannot collide with an object or another fixture when it moves.

Check that all external covers and rigging hardware are securely fastened.

Do not operate the fixture with missing or damaged covers, shields or any optical component.

Block access below the work area and work from a stable platform whenever installing, servicing or moving the fixture.

In the event of an operating problem, stop using the fixture immediately and disconnect it from power. Do not attempt to use a fixture that is obviously damaged.

Do not modify the fixture or install other than genuine RUSH by Martin™ parts.

Refer any service operation not described in this manual to a qualified technician.

# Introduction

The RUSH Multibeam 2™ is a versatile effect featuring two moveable LED bars, each with 5 individually controllable narrow beams for powerful mid-air effects. It punches out 10 intense and narrow long-throw beams and features electronic dimming and strobe effects.

The Multibeam 2 can be controlled via DMX or set to stand-alone operation, where you can choose from Auto trig (preprogrammed shows) or Music trig (sound-activated shows). Preprogrammed shows can also be selected via DMX. Fixtures can be linked together and set to master/slave stand-alone operation for synchronized stand-alone shows across multiple fixtures.

The fixture is supplied with a 1.5 m (5 ft) power cable (local power plug not included) and an omega-type mounting bracket.

## Before using the product for the first time

1. Read 'Safety information' on page 4 before installing, powering, operating or servicing the fixture.
2. Unpack and ensure that there is no transportation damage before using the fixture. Never attempt to operate a damaged fixture.
3. If the fixture is not going to be hard-wired to an AC mains power source, install a local power plug (not supplied) on the end of the supplied power cable.
4. Before operating, ensure that the voltage and frequency of the local power supply match the mains power requirements of the fixture.
5. Check the Martin Professional website at [www.martin.com](http://www.martin.com) for the most recent user documentation and technical information about the fixture. RUSH by Martin™ user manual revisions are identified by the revision letter at the bottom of the inside cover.

Note that whenever AC mains power is applied to the fixture, it will reset all effects and functions to their home positions. The LED bars will move. This process usually takes around 20 seconds.



# Physical installation



**Read ‘Safety information’ on page 4 before installing the fixture.**

The fixture is designed for indoor use only and must be used in a dry location with adequate ventilation. Ensure that none of the fixture’s ventilation slots are blocked and ensure that the product is fastened to a secure structure or surface.

## Fastening the fixture to a flat surface

The fixture can be fastened to a hard, fixed, flat surface that is oriented at any angle. Ensure that the surface and all fasteners used can support at least 10 times the weight of all fixtures and equipment they will support.

Fasten the fixture securely. Do not stand it on a surface or leave it where it can be moved or fall over. If you install the fixture in a location where it may cause injury or damage if it falls, secure it as directed below with a securely anchored safety cable that will hold the fixture if the primary fastening method fails.

## Mounting the fixture on a truss

The fixture can be clamped to a truss or similar rigging structure in any orientation. When installing the fixture hanging vertically down, you can use an open-type clamp such as a G-clamp. When installing in any other orientation, you must use a half-coupler clamp (see illustration on right) that completely encircles the truss chord.



To clamp the fixture to a truss:

1. Check that the rigging structure can support at least 10 times the weight of all fixtures and equipment to be installed on it.
2. Block access under the work area.
3. The fixture is supplied with an omega-type bracket to which a rigging clamp can be attached. Bolt a rigging clamp securely to the bracket. The bolt used must be M12, grade 8.8 steel minimum, and fastened with a self-locking nut.
4. Fasten the omega bracket to the base of the fixture using the bracket’s quarter-turn fasteners. Turn quarter-turn fasteners a full 90° to lock them (see illustration on right).
5. Working from a stable platform, hang the fixture on the truss and fasten the rigging clamp onto the truss.

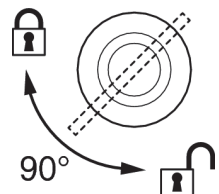

6. Secure the fixture with a safety cable as directed below.
7. Check that the LED bars will not collide with other fixtures or objects.

### **Securing with a safety cable**

Secure the fixture with a safety cable (or other secondary attachment) that is approved for the weight of the fixture so that the safety cable will hold the fixture if a primary attachment fails. Loop the safety cable through the eyebolt in the side of the fixture (see **9** in illustration on page 12) and around a secure anchoring point.

## AC power



**Read 'Safety information' on page 4 before connecting the fixture to AC mains power.**



**Warning! The mains power input cable supplied with the fixture is rated 6 A and can supply only one fixture with mains power. Do not connect any device to the fixture's MAINS OUT power throughput socket when using this input cable. If you want to connect other fixtures to the MAINS OUT socket, see 'Linking fixtures to power in a chain' on page 12.**

For protection from electric shock, the fixture must be grounded (earthed). The power distribution circuit must be equipped with a fuse or circuit breaker and ground-fault (earth-fault) protection.

Socket outlets or external power switches used to supply the fixture with power must be located near the fixture and easily accessible so that the fixture can easily be disconnected from power.

Do not insert or remove live Neutrik PowerCon connectors to apply or cut power, as this may cause arcing at the terminals that will damage the connectors.

Do not use an external dimming system to supply power to the fixture, as this may cause damage to the fixture that is not covered by the product warranty.

The fixture can be hard-wired to a building electrical installation if you want to install it permanently, or a power plug (not supplied) that is suitable for the local power outlets can be installed on the power cable.

If you install a power plug on the power cable, follow the plug manufacturer's instructions and connect the wires in the power cable as shown in this table:

	Earth, Ground or 	Neutral or N	Live or L
<b>US system</b>	Green	White	Black
<b>EU system</b>	Yellow/green	Blue	Brown

The fixture has an auto-ranging power supply that accepts AC mains power at 100-240 V at 50/60 Hz. Do not apply AC mains power at any other voltage or frequency to the fixture.

## Linking fixtures to power in a chain

If you obtain a 12 AWG or 2.5 mm<sup>2</sup> power input cable and 12 AWG or 2.5 mm<sup>2</sup> throughput cables from Martin™ (see Accessories on page 29), you can relay mains power from one fixture to another by connecting fixtures to power in a linked daisy-chain, MAINS OUT throughput socket to MAINS IN input socket.

Using 12 AWG or 2.5mm<sup>2</sup> cables from Martin™, you can link:

- Maximum seven (7) RUSH Multibeam 2 fixtures in total at 100-120 V, or
- Maximum twelve (12) RUSH Multibeam 2 fixtures in total at 200-240 V.

## Fixture overview

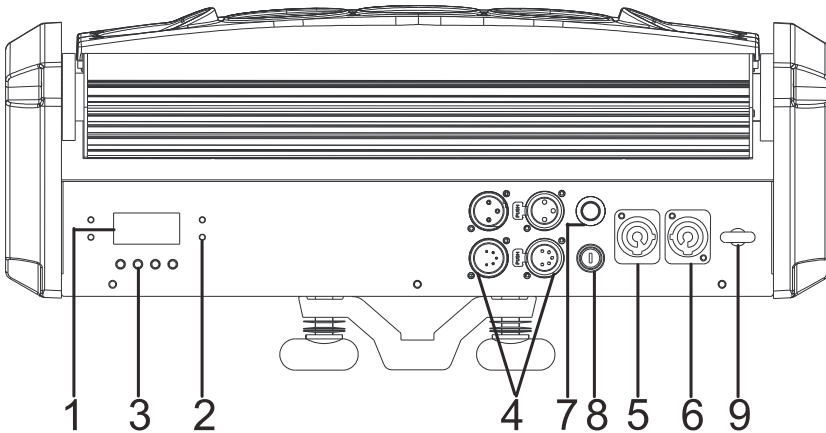

**1 - Display**

**2 - LEDs**

The four LEDs on the rear of the fixture have the following functions:

DMX	On	Valid DMX signal present
MASTER	On	Master mode
SLAVE	On	Slave mode
SOUND	Flashing	Sound activation (Music trig)

### 3 - Buttons

MENU	<ul style="list-style-type: none"><li>• Activate the menu mode functions, or</li><li>• Return to the previous level of the menu structure, or</li><li>• Press and hold to exit the menus</li></ul>
DOWN	Go down a menu branch
UP	Go up a menu branch
ENTER	Confirm the selected function

### 4 - DMX XLR input/output sockets

3-pin and 5-pin XLR sockets are provided for DMX input and output (throughput).

### 5 - Mains power input

A blue Neutrik PowerCon socket is provided to connect the fixture to AC mains power.

### 6 - Mains power throughput

See Safety information on page 4. The light-grey Neutrik PowerCon socket can be used to supply power to other fixtures only if the supplied power input cable is replaced as directed in this manual and safety limits are respected.

### 7 - Microphone

Built-in microphone for sound-activated scene changes in stand-alone Music trig mode.

### 8 - Fuse

The T 6.3A fixture fuse is located in a fuse holder next to the power input/output connectors.

### 9 - Safety cable attachment

Eyebolt for securing the fixture with a secondary attachment such as a safety cable.

## Control data link

A DMX 512 data link is required in order to control the fixture via DMX. The fixture has 3-pin and 5-pin XLR connectors for DMX data input and output.

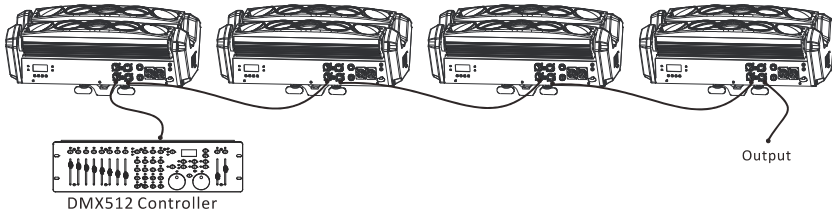

The number of daisy-chained fixtures is limited by the number of DMX channels required by the fixtures in relation to the maximum 512 channels available in one DMX universe. Note that if independent control of a fixture is required, it must have its own DMX channels. Fixtures that are required to behave identically can share the same DMX address and channels. To add more fixtures or groups of fixtures when the above limit is reached, add a DMX universe and another daisy-chained link.

### Tips for reliable data transmission

Use shielded twisted-pair cable designed for RS-485 devices: standard microphone cable cannot transmit control data reliably over long runs. 24 AWG cable is suitable for runs up to 300 meters (1000 ft.). Heavier gauge cable and/or an amplifier is recommended for longer runs. The pin-out on all connectors is pin 1 = shield, pin 2 = cold (-), and pin 3 = hot (+). Pins 4 and 5 in the 5-pin XLR connectors are not used in the fixture but are available for possible additional data signals as required by the DMX512-A standard. Standard pin-out is pin 4 = data 2 cold (-) and pin 5 = data 2 hot (+).

To split the link into branches, use a splitter such as the Martin 4-Channel Opto-Isolated RS-485 Splitter/Amplifier. Terminate the link by installing a DMX termination plug in the output socket of the last fixture. The termination plug, which is a male XLR plug with a 120 Ohm, 0.25 W resistor soldered between pins 2 and 3, “soaks up” the control signal so it does not reflect and cause interference. If a splitter is used, terminate each branch of the link.

### Connecting the DMX data link

To connect the fixture to data:

1. Connect the DMX data output from the controller to the first fixture’s male XLR DMX input connector.

2. Connect the first fixture's DMX output to the DMX input of the next fixture and continue connecting fixtures output to input. Terminate the last fixture on the link with a DMX termination plug.

## Fixture setup

This section explains the options available to change the fixture's settings. Settings are made using the menus available in the control panel and are retained when the fixture is powered off.

A complete map of the control menu structure and brief explanations of their purposes can be found in 'Control menus' on page 23.

### Using the control panel

- To access the control menus in the control panel, press the MENU button.
- Navigate the menu structure using the ENTER, DOWN and UP buttons.
- Scroll between menu items using the DOWN and UP buttons.
- Select any required menu option using the ENTER button.
- To return to the previous level in the menu structure without making a change, press the MENU button.
- To exit the menus, press and hold the MENU button.

### DMX function settings

DMX function settings include the DMX address and Master/Slave mode.

#### *DMX addressing*

The fixture can be controlled using signals sent by a DMX controller over up to 45 channels. The DMX address, also known as the start channel, is the first channel used to receive instructions from the DMX controller. Each DMX-controlled fixture must have a DMX address set. For example, if a fixture has a DMX address of 1 and you want to use all 45 channels, then the next fixture can have a DMX address of 46, the next 91, then 136, until the 512 channels in one DMX universe have all been allocated.

For independent control, each fixture must be assigned its own DMX channels. Two fixtures of the same type may share the same address, if identical behavior is desired. Address sharing can be useful for diagnostic purposes and symmetric control, particularly when combined with the inverse pan and tilt options.

To set the fixture's DMX address:

1. In the fixture's control panel, use the UP and DOWN buttons to select DMX ADDRESS and press ENTER. The fixture's currently set DMX address will blink in the display.

2. Use the UP and DOWN buttons to select a new address (1 to 512).
3. Once the address has been selected, press ENTER to set it (or to return to the previous menu level without making a change, press MENU).

### ***Master/slave mode***

Fixtures on a data link can run synchronized shows in stand-alone operation if you set the first fixture on the data link to Master mode and the other fixtures to Slave mode. In Master/Slave mode, the first fixture runs a preprogrammed or sound-activated stand-alone show, and the other fixtures run a show that is synchronized with the first fixture.

In Master/Slave mode, all fixtures must be in stand-alone operation: they must not be receiving a DMX signal and BLACKOUT must be set to No.

Fixtures' MASTER and SLAVE LEDs light to indicate the mode they are set to. If the master fixture is set to Music trig, its SOUND LED flashes in sync with the music beat.

*Important: set only the first fixture on the data link to MASTER mode.*

To adjust a fixture's MASTER/SLAVE settings:

1. Select SLAVE MODE and press the ENTER button.
2. Use the UP and DOWN buttons to select from:
  - **Master** – fixture runs a stand-alone show (sound-activated or preprogrammed) and sends synchronizing information to connected slave fixtures, or
  - **Slave 1** – fixture receives synchronizing information and runs the same show as the master fixture, or
  - **Slave 2** – fixture receives synchronizing information and runs a show that is in sync with the master fixture's show but is not identical to it.
3. Once the mode has been selected, press the ENTER button to set it. Or to return to the higher level of the menu structure without making a change, press the MENU button again.

### **Show settings**

Show settings determine the behavior of the fixture when it is disconnected from DMX and configure the fixture's stand-alone behavior.

### ***Blackout mode***

The fixture can be set so that, if it does not receive a DMX signal, it either blacks out or runs its stand-alone show. This is set to No (fixture runs stand-alone show when it does not receive DMX) by default.

To adjust the blackout settings:

1. Select BLACKOUT and press the ENTER button to confirm.



2. Use the DOWN and UP buttons to select Yes (blackout if no DMX) or No (run stand-alone show if no DMX).
3. Press the ENTER button to confirm (or, to return to the higher level of the menu structure without any change, press the MENU button).

### ***Show mode (Auto trig)***

Show mode provides 12 preprogrammed stand-alone shows.

To set a fixture's show mode:

1. Set BLACKOUT to No (see above).
2. Select SHOW MODE and press the ENTER button to confirm.
3. Use the DOWN and UP buttons to select Show 0 (random show) or Show 1 to Show 12 (preprogrammed shows).
4. Once the show has been selected, press the ENTER button to set (or, to return to the higher level of the menu structure without any change press the MENU button).

### ***Sound state (Music trig)***

The fixture has a built-in microphone that allows its show to be triggered by a music beat, for example.

To turn on Music trig:

1. Set BLACKOUT to No (see above).
2. Select SOUND STATE and press the ENTER button to confirm.
3. Use the DOWN and UP buttons to select On (Music trig on) or Off (Music trig off).
4. Press the ENTER button to set it (or, to return to the higher level of the menu structure without any change press the MENU button).

### ***Automatically turn off display backlight***

The display backlighting remains on permanently by default when power is applied to the fixture. If you prefer, you can enable Sleep mode, where the backlighting goes off automatically when the buttons and menus have not been used for a short period:

1. Select BACKLIGHT and press the ENTER button to confirm.
2. Use the DOWN and UP buttons to select LED Off (Sleep mode disabled) or LED On (Sleep mode enabled) and press the ENTER button to confirm.
3. Press the ENTER button to confirm (or, to return to the higher level of the menu structure without any change press the MENU button).

## **Fixture settings**

Tilt can be inverted and the LED activation sequence can be reversed on one or both LED bars. These options can be used to create symmetrical effects.

### ***Tilt inverse 1***

To adjust the LED Bar 1 tilt settings:

1. Select TILT 1 INVERSE and press the ENTER button to confirm.
2. Use the DOWN and UP buttons to select Yes (movable LED bar 1 inversion) or No (normal).
3. Press the ENTER button to confirm (or, to return to the higher level of the menu structure without any change press the MENU button).

### ***Tilt inverse 2***

To adjust the LED Bar 2 tilt settings:

1. Select TILT 2 INVERSE and press the ENTER button to confirm.
2. Use the DOWN and UP buttons to select Yes (movable LED bar 2 inversion) or No (normal).
3. Press the ENTER button to confirm (or, to return to the higher level of the menu structure without any change press the MENU button).

### ***LED reverse***

To adjust the LED sequence reversal settings.

1. Select REVERSE and press the ENTER button to confirm.
6. Use the DOWN and UP buttons to select the Yes (LED sequence left to right) or No (normal, LED sequence from right to left). Press the ENTER button to set it (or, to return to a higher level of the menu structure without any change press the MENU button).

## **Fixture test**

Automatic tests of all functions can be run from the control menus.

### ***Auto test***

To perform a complete test of all of the fixture functions:

1. Select AUTO TEST and press the ENTER button to confirm. The fixture will run the auto test routine.
7. To return to the higher level of the menu structure without any change press the MENU button.

## **Fixture information**

### ***Fixture temperature readout***

To check the onboard temperature of the fixture:

1. Select TEMP and press ENTER. The display will show the temperature of the unit.
2. To return to a higher level of the menu structure, press MENU.

### ***Fixture operating hours counter***

To see how many hours the fixture has been used:

1. Select FIXTURE HOURS and press the ENTER button to confirm. The number of hours will be shown.
8. To return to the higher level of the menu structure without any change press the MENU button.

### ***Software version***

To see what software version is installed in the fixture:

1. Select SOFTWARE VERSION and press the ENTER button to confirm. The firmware version will be shown.
2. To return to the higher level of the menu structure without any change press the MENU button.

## **Reset functions and settings**

1. Select RESET and press the ENTER button to confirm. The fixture will reset the fixture.
2. To return to the higher level of the menu structure without any change press the MENU button.

## **Effects**

This section describes DMX-controllable effects that require particular explanation. See DMX protocol starting on page 23 for a full list of the DMX channels and values required to control the different effects.

## **Tilt movement**

Each of the two moveable LED bars can be tilted from 50° to 170° independently.

## Strobe effects

The strobe effect provides instant open and blackout, variable speed regular strobe, random strobe and various pulse effects.

## Electronic dimming

The overall intensity of all the beams can be adjusted 0-100 %.

## Individual RGBW color control

Individual control of red, green, blue and white intensity in each of the 10 LED beams is available.

## Maintenance



**Read Safety information on page 4 before servicing the fixture.**

Refer any service operation not described in this user manual to a qualified service technician.

Disconnect mains power before cleaning or servicing the fixture.

Fixtures must be serviced in an area where there is no risk of anyone being injured by failing parts, tools or other materials.

## Cleaning

Excessive dust, smoke fluid, and particle buildup degrades performance, causes overheating and will damage the fixture. Damage caused by inadequate cleaning or maintenance is not covered by the product warranty.

The cleaning of external optical lenses must be carried out periodically to optimize light output. Cleaning schedules for lighting fixtures vary greatly depending on the operating environment. It is therefore impossible to specify precise cleaning intervals for the fixture. Environmental factors that may result in a need for frequent cleaning include:

- Use of smoke or fog machines.
- High airflow rates (near air conditioning vents, for example).
- Presence of cigarette smoke.
- Airborne dust (from stage effects, building structures and fittings or the natural environment at outdoor events, for example).

If one or more of these factors is present, inspect fixtures within their first 100 hours of operation to see whether cleaning is necessary. Check again at frequent intervals. This procedure will allow you to assess cleaning

requirements in your particular situation. If in doubt, consult your RUSH by Martin dealer about a suitable maintenance schedule.

Use gentle pressure only when cleaning, and work in a clean, well-lit area. Do not use any product that contains solvents or abrasives, as these can cause surface damage.

To clean the fixture:

1. Disconnect the fixture from power and allow it to cool for at least 15 minutes.
2. Vacuum or gently blow away dust and loose particles from the outside of the fixture and the air vents with low-pressure compressed air.
3. Clean the LED lenses by wiping gently with a soft, clean lint-free cloth moistened with a weak detergent solution. Do not rub the surface hard: lift particles off with a soft repeated press. Dry with a soft, clean, lint-free cloth or low-pressure compressed air. Remove stuck particles with an unscented tissue or cotton swab moistened with glass cleaner or distilled water.
4. Check that the fixture is dry before reapplying power.

## **Fuse replacement**

If the fixture is completely dead, the fixture's primary fuse F1 may have blown and it may be necessary to install a new fuse. This fuse is located in a fuseholder next to the Mains OUT socket on the connections panel. (see Fixture overview on page 11).

To change the fuse:

1. Disconnect the fixture from power and allow it to cool for at least 15 minutes.
2. Use a large flat-bladed screwdriver to unscrew the cap of the fuseholder.
3. Replace the fuse with one of the same type and rating only.
4. Reinstall the fuseholder cap before reapplying power.

## **Service and repairs**

There are no user serviceable parts inside the fixture. Do not open the housing.

Do not try to repair the fixture by yourself as this may result in damage or malfunction, and it may potentially void your product warranty. The fixture must be serviced or repaired by an authorized RUSH by Martin™ service technician only.

Installation, on-site service and maintenance can be provided worldwide by the Martin Professional Global Service organization and its approved agents, giving owners access to Martin's expertise and product knowledge in a

partnership that will ensure the highest level of performance throughout the product's lifetime. Please contact your RUSH by Martin supplier for details.

# DMX protocol

Channel	Value	Function
1		<b>Preprogrammed shows</b>
	0-7	Blackout
	8-27	Show 1
	28-47	Show 2
	48-67	Show 3
	68-87	Show 4
	88-107	Show 5
	108-127	Show 6
	128-147	Show 7
	148-167	Show 8
	168-187	Show 9
	188-207	Show 10
	208-227	Show 11
	228-247	Show 12
248-255	Random Show	
2	0-255	Tilt 1 movement: 50° - 170°
3	0-255	Tilt 2 movement: 50° - 170°
4	0-255	Dimmer 0-100%
5		<b>Strobe</b>
	0-7	Open
	8-131	Strobe, slow-fast
	132-139	Open
	140-181	Pulse effect, fast close, slow open
	182-189	Open
	190-231	Pulse effect, slow close, fast open
	232-239	Open
	240-247	Random strobe
248-255	Open	
6	0-255	Red LED 1 - 0-100%
7	0-255	Green LED 1 - 0-100%
8	0-255	Blue LED 1 - 0-100%
9	0-255	White LED 1 - 0-100%
10	0-255	Red LED 2 - 0-100%
11	0-255	Green LED 2 - 0-100%
12	0-255	Blue LED 2 - 0-100%
13	0-255	White LED 2 - 0-100%
14	0-255	Red LED 3 - 0-100%
15	0-255	Green LED 3 - 0-100%
16	0-255	Blue LED 3 - 0-100%

Channel	Value	Function
17	0-255	White LED 3 - 0-100%
18	0-255	Red LED 4 - 0-100%
19	0-255	Green LED 4 - 0-100%
20	0-255	Blue LED 4 - 0-100%
21	0-255	White LED 4 - 0-100%
22	0-255	Red LED 5 - 0-100%
23	0-255	Green LED 5 - 0-100%
24	0-255	Blue LED 5 - 0-100%
25	0-255	White LED 5 - 0-100%
26	0-255	Red LED 6 - 0-100%
27	0-255	Green LED 6 - 0-100%
28	0-255	Blue LED 6 - 0-100%
29	0-255	White LED 6 - 0-100%
30	0-255	Red LED 7 - 0-100%
31	0-255	Green LED 7 - 0-100%
32	0-255	Blue LED 7 - 0-100%
33	0-255	White LED 7 - 0-100%
34	0-255	Red LED 8 - 0-100%
35	0-255	Green LED 8 - 0-100%
36	0-255	Blue LED 8 - 0-100%
37	0-255	White LED 8 - 0-100%
38	0-255	Red LED 9 - 0-100%
39	0-255	Green LED 9 - 0-100%
40	0-255	Blue LED 9 - 0-100%
41	0-255	White LED 9 - 0-100%
42	0-255	Red LED 10 - 0-100%
43	0-255	Green LED 10 - 0-100%
44	0-255	Blue LED 10 - 0-100%
45	0-255	White LED 10 - 0-100%



## Control menus

To access the control menus, press the MENU button. Use the UP and DOWN buttons to navigate the menus. Select any required menu option using the ENTER button. For more information, see 'Using the control ' on page 13.

Default fixture settings are shown in **bold**.

Menu	Setting/value	Explanation
DMX Address	<b>001</b> –512	Fixture DMX address setting
Slave Mode	Master	Set fixture to act as Master
	Mode 1	Set fixture to act as Slave, Mode 1
	Mode 2	Set fixture to act as Slave, Mode 2
Show Mode	Show 0	Random show
	Show 1 - Show 12	Pre-programmed shows 1 - 12
Sound State	<b>Off</b>	Music trig off
	On	Music trig on
Blackout	<b>No</b>	Fixture runs in stand-alone mode when it is not receiving a DMX signal
	Yes	Fixture blacks out when it does not receive a DMX signal.
Backlight	<b>Off</b>	Display backlight does not go into sleep mode, remains on permanently
	On	Display backlight goes into sleep mode if control buttons not used for a short period
Tilt 1 Inverse	Yes/ <b>No</b>	Invert tilt direction, LED bar 1
Tilt 2 Inverse	Yes/ <b>No</b>	Invert tilt direction, LED bar 2
Reverse	Yes/ <b>No</b>	Reverse LED sequence
Auto Test		Automatic test of all functions
Temp		Display fixture's current temperature
Fixture Hours		Fixture operating hour counter
Software Version		Currently installed firmware version
Reset	Yes/ <b>No</b>	Reset all effects

# Troubleshooting

This section describes a few common problems that may occur during operation and provides some suggestions for easy troubleshooting:

Symptom	Potential cause	Remedies
No light from fixture or fans not working.	Power supply issue, such as blown fuse, faulty connector or damaged cable.	Check whether fixture's power indicator LED is lit. Check all power connections and cables. Replace fixture's primary fuse.
Fixture does not react to music beat.	Sound activation disabled. Sound level too low to activate music trigger.	Ensure that fixture is not connected to a DMX signal. Check master/slave settings Tap the microphone to ensure that it is functioning. The fixture should react when in Music trig mode. Place fixture and music source closer together.
One of the control channels is unresponsive or only responds intermittently.	DMX setup or DMX link fault. Damaged step motor or cable connection between LED bars and body.	See next section. Contact your RUSH by Martin authorized distributor for assistance.

Symptom	Potential cause	Remedies
Fixture does not respond to DMX control.	<p>Incorrect DMX addressing.</p> <p>Fault on DMX link due to damaged connector or cable, or potential interference from proximity to a high-voltage installation.</p>	<p>Ensure that fixture's DMX address matches address set on DMX control device.</p> <p>Check that fixture DMX LED is on, and if not, check all DMX cables and connections.</p> <p>Ensure that DMX link is terminated.</p> <p>Check that all devices on DMX link use standard DMX polarity.</p> <p>Attempt to control the fixture with another DMX control device.</p> <p>Move or shield link if it is very close to an unshielded high-voltage installation.</p>

# Specifications

## Physical

Weight ..... 8 kg (17.7 lbs.)  
Dimensions ..... 473 x 248 x 167 mm (18.6 x 9.8 x 6.6 in.)

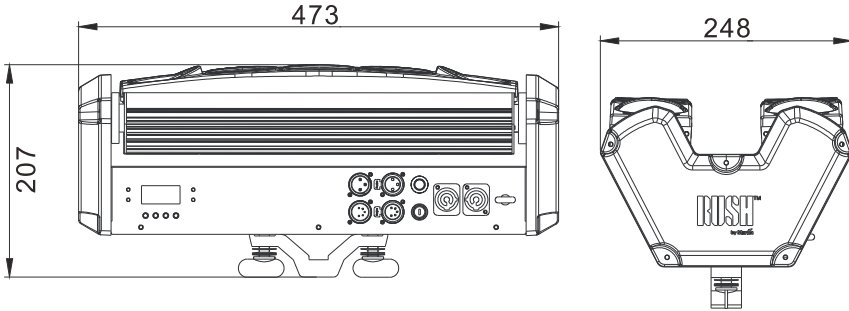

## Dynamic Effects

Color mixing ..... RGBW  
Color selection ..... 32 color presets  
Electronic 'shutter' effect ..... Strobe and pulse effects, instant  
..... open and blackout  
Pre-programmed shows ..... Choice of 12  
Electronic dimming ..... 0 - 100%

## Control and Programming

Control options ..... DMX, stand-alone, master/slave  
DMX channels ..... 45  
Stand-alone trigger options ..... Music trig, Auto trig  
Setting and addressing ..... Control panel with LCD display  
DMX compliance ..... USITT DMX512/1990

## Optics and Photometric Data

Light source ..... 10 x 10 W RGBW Cree XM L-LEDs  
Minimum LED lifetime ..... 50 000 hours (to >70% luminous output)\*  
Beam angle ..... 8°

*\*Figure obtained under manufacturer's test conditions*

## Construction

Color ..... Black  
Housing ..... High-impact flame-retardant thermoplastic  
Protection rating ..... IP 20

## Installation

Mounting points ..... Pair of quarter-turn fastener sockets  
Location ..... Indoor use only, must be fastened to surface or structure  
Orientation ..... Any  
Minimum distance to illuminated surfaces ..... 2 m (6.4 ft.)  
Minimum distance to combustible material ..... 0.2 m (8 in.)

## Connections

AC power input ..... Neutrik PowerCon  
AC power throughput ..... Neutrik PowerCon  
DMX data in/out ..... 3-pin & 5-pin locking XLR

## Electrical

AC power ..... 100-240 V nominal, 50/60 Hz  
Power consumption ..... 137 W  
Fuse ..... T 6.3 A  
Power supply unit ..... Auto-ranging electronic switch mode  
*Power consumption figures are typical, not maximum. Allow for +/-10% variation*

## Thermal

Cooling ..... Forced air  
Maximum ambient temperature ( $T_a$  max.) ..... 40° C (104° F)  
Minimum ambient temperature ( $T_a$  min) ..... 0° C (32° F)

## Included Items

Power cable, 6 A, 18 AWG, 0.75 mm<sup>2</sup>, UL- listed, H05VV-F, 1.5 m, without mains plug  
Omega-type mounting bracket for rigging clamp attachment

## Accessories

### *Cables for connection to power in chains, 16 A, US/Canada*

Power input cable, 12 AWG, SJT,  
with PowerCon input connector, 3 m (9.8 ft.) ..... P/N 11541503  
Power relay cable, 12 AWG, SJT,  
with PowerCon connectors, 1.4 m (4.6 ft.) ..... P/N 11850099  
Power relay cable, 12 AWG, SJT,  
with PowerCon connectors, 2.25 m (7.4 ft.) ..... P/N 11850100  
Power relay cable, 12 AWG, SJT,  
with PowerCon connectors, 3.25 m (10.7 ft.) ..... P/N 11850101

### *Cables for connection to power in chains, 16 A, EU*

Power input cable, 2.5 mm<sup>2</sup>, H05VV-F,  
with PowerCon input connector, 3 m (9.8 ft.) ..... P/N 11541007

Power relay cable, 2.5 mm <sup>2</sup> , H05VV-F, with PowerCon connectors, 1.4 m (4.6 ft.).....	P/N 11541008
Power relay cable, 2.5 mm <sup>2</sup> , H05VV-F, with PowerCon connectors, 2.25 m (7.4 ft.).....	P/N 11541009
Power relay cable, 2.5 mm <sup>2</sup> , H05VV-F, with PowerCon connectors, 3.25 m (10.7 ft.).....	P/N 11541010

*Power connectors*

Neutrik PowerCon NAC3FCA power input connector, cable mount, blue .....	P/N 05342804
Neutrik PowerCon NAC3FCB power output connector, cable mount, light grey .....	P/N 05342805

*Installation hardware*

Half-coupler clamp .....	P/N 91602005
G-clamp (suspension vertically downwards only).....	P/N 91602003
Quick-trigger clamp (suspension vertically downwards only)....	P/N 91602007
Safety wire, safe working load 50 kg .....	P/N 91604003

**Related Items**

RUSH Software Uploader 1™ .....	P/N 91611399
---------------------------------	--------------

**Ordering Information**

RUSH Multibeam 2™ in cardboard box.....	P/N 90480030
---	--------------

*Specifications are subject to change without notice. For latest product specifications, see [www.martin.com](http://www.martin.com)*



**Disposing of this product**

RUSH by Martin™ products are supplied in compliance with Directive 2012/19/EC of the European Parliament and of the Council of the European Union on WEEE (Waste Electrical and Electronic Equipment), where applicable. Help preserve the environment! Ensure that this product is recycled at the end of its life. Your supplier can give details of local arrangements for the disposal of RUSH by Martin products





Innovation • Quality • Performance