

Membrane System User's Manual

L1-Series



This Page
Left Blank

TABLE OF CONTENTS

INTRODUCTION 4

SAFETY 5

FEED WATER AND OPERATION SPECIFICATIONS 6

REJECTION, RECOVERY AND FLOW RATES 7

SYSTEM INSTALLATION AND START-UP PROCEDURES..... 8

MEMBRANE ELEMENTS..... 10

SYSTEM IDENTIFICATION..... 11

MEMBRANE INSTALLATION, REMOVAL AND REPLACEMENT 12

OPERATION DO’S AND DON’TS 14

SPECIFICATIONS..... 15

OPERATION AND MAINTENANCE..... 16

PREPARING UNIT FOR STORAGE OR SHIPMENT..... 17

REVERSE OSMOSIS TROUBLESHOOTING 18

TEMPERATURE CORRECTION FACTORS FOR MEMBRANE 20

SERVICE ASSISTANCE 21

OPERATION LOG 22

SYSTEM DRAWING..... 23

L1-200 SERIES FLOW DIAGRAM..... 24

L1 - SERIES ELECTRICAL SCHEMATIC 110V/60HZ 24

L1 - SERIES ELECTRICAL SCHEMATIC 220V/50HZ 26

REVERSE OSMOSIS SYSTEM WARRANTY 27

INTRODUCTION

Your L1 - Series RO System is a durable piece of equipment which, with proper care, will last for many years. This User's Manual outlines installation, operation, maintenance and troubleshooting details vital to the sustained performance of your system.

If your system is altered at the site of operation, or if the feed water conditions change, please consult your local dealer or distributor for assistance.



NOTE: IN ORDER TO MAINTAIN THE MANUFACTURER'S WARRANTY, AN OPERATING LOG MUST BE MAINTAINED AND COPIES WILL NEED TO BE SENT TO YOUR LOCAL DEALER OR DISTRIBUTOR FOR REVIEW.



NOTE: PRIOR TO OPERATING OR SERVICING THE REVERSE OSMOSIS SYSTEM, THIS USER'S MANUAL MUST BE READ AND FULLY UNDERSTOOD. KEEP THIS AND OTHER ASSOCIATED INFORMATION FOR FUTURE REFERENCE AND FOR NEW OPERATORS OR QUALIFIED PERSONNEL NEAR THE SYSTEM.

SAFETY

The Safety section of this User's Manual outlines the various safety headings used throughout this manual's text and are enhanced and defined below:

NOTE: INDICATES STATEMENTS THAT PROVIDE FURTHER INFORMATION AND CLARIFICATION.



CAUTION: INDICATES STATEMENTS THAT ARE USED TO IDENTIFY CONDITIONS OR PRACTICES THAT COULD RESULT IN EQUIPMENT OR OTHER PROPERTY DAMAGE.



WARNING: INDICATES STATEMENTS THAT ARE USED TO IDENTIFY CONDITIONS OR PRACTICES THAT COULD RESULT IN INJURY OR LOSS OF LIFE. FAILURE TO FOLLOW WARNINGS COULD RESULT IN SERIOUS INJURY OR EVEN DEATH.



DO NOT UNDER ANY CIRCUMSTANCE REMOVE ANY CAUTION, WARNING, OR OTHER DESCRIPTIVE LABELS FROM THE SYSTEM.



PLEASE READ THE ENTIRE MANUAL BEFORE PROCEEDING WITH THE INSTALLATION AND STARTUP. YOUR FAILURE TO FOLLOW ATTACHED INSTRUCTIONS OR OPERATING PARAMETERS MAY LEAD TO THE PRODUCT'S FAILURE, WHICH CAN CAUSE PROPERTY DAMAGE AND/OR PERSONAL INJURY.

- DO NOT USE WHERE THE WATER IS MICROBIOLOGICALLY UNSAFE OR OF UNKNOWN QUALITY WITHOUT ADEQUATE DISINFECTION BEFORE OR AFTER THE SYSTEM.
- PRETREATMENT MUST BE SUFFICIENT TO ELIMINATE CHEMICALS, ORGANICS OR INORGANICS THAT COULD ATTACK THE MEMBRANE MATERIAL.
- ALWAYS TURN OFF THE UNIT, SHUT OFF THE FEED WATER, AND

DISCONNECT THE ELECTRICAL POWER BEFORE WORKING ON THE UNIT.

- NEVER ALLOW THE PUMP TO RUN DRY.
- NEVER ALLOW THE UNIT TO FREEZE OR OPERATE WITH A FEED WATER TEMPERATURE ABOVE 100°F.

FEED WATER AND OPERATION SPECIFICATIONS

Nothing has a greater effect on a reverse osmosis system than the feed water quality.



NOTE: IT IS VERY IMPORTANT TO MEET THE MINIMUM FEED WATER REQUIREMENTS. FAILURE TO DO SO WILL CAUSE THE MEMBRANE TO FOUL AND VOID THE MANUFACTURER'S WARRANTY.

OPERATING LIMITS

Operating Parameters:*

Feed Temperature	40 - 85°F
System Inlet Pressure	45 - 85 PSIG
Maximum Operating Pressure (@77°F)	120 PSIG (Nominal)

*If any of the feed water parameters are not within the limits given, consult your local dealer or distributor for assistance.

Feed Water Requirements:**

Maximum SDI Rating	< 3
Maximum Turbidity	1 NTU
Maximum Free Chlorine and/or Chloramines	0 PPM
pH (continuous)	3 - 11
pH (cleaning - 30 min.)	2 - 12

**If any of the feed water parameters are not within the limits given, consult your local dealer or distributor for assistance.



NOTE: HIGHER TDS AND/OR LOWER TEMPERATURES WILL REDUCE THE SYSTEM'S PRODUCTION.

REJECTION, RECOVERY AND FLOW RATES

L1 - Series Reverse Osmosis Systems are designed to produce permeate water at the capacities indicated by the suffix in the system's name under the conditions listed above. For example, the L1-300 produces 300 gallons per day of permeate water at the listed operating test conditions.

The amount of total dissolved solids (TDS) rejected by the membrane is expressed as a percentage. For example, a 98.5% rejection rate means that 98.5% of total dissolved solids do not pass through the membrane. To calculate the % rejection, use the following formula:

$$\% \text{ Rejection} = [(\text{Feed TDS} - \text{Product TDS}) / \text{Feed TDS}] \times 100$$

Example:

$$98.5\% = [(550-8.25)/550] \times 100$$



NOTE: ALL TDS FIGURES MUST BE EXPRESSED IN THE SAME UNITS, TYPICALLY PARTS PER MILLION (PPM) OR MILLIGRAMS PER LITER (MG/L).

L1 - Series Reverse Osmosis Systems are designed to reject up to 98.5% NaCl, unless computer projections have been provided or stated otherwise.

The amount of permeate water recovered for use is expressed as a percentage. To calculate % recovery, use the following formula:

$$\% \text{ Recovery} = (\text{Product Water Flow Rate} / \text{Feed Water Flow Rate}) \times 100$$

Example:

$$28\% = (0.14/0.50) \times 100$$



NOTE: ALL FLOW RATES MUST BE EXPRESSED IN THE SAME UNITS, TYPICALLY GALLONS PER MINUTE (GPM).

SYSTEM INSTALLATION AND START-UP PROCEDURES

1. Inspect the system for any damage that could have occurred during shipment. Although our systems have been individually inspected, complete a quick inspection of the fittings, tubing and other components.
2. Please provide a reasonable amount of space for installation and leave 6 inches of space below the filter housings for ease of maintenance.



NOTE: THE REVERSE OSMOSIS SYSTEM SHOULD BE INSTALLED INDOORS AND IT IS SUGGESTED THAT IT NOT BE IN DIRECT SUNLIGHT OR EXTREME COLD.

3. Connect the 3/8" tube fitting to an incoming water source. The minimum water pressure should be at least 30 psi. The system's minimum operating pressure is 80 PSI, but the optimum operating pressure is 100 psi.



NOTE: DO NOT OPERATE AT A PRESSURE EXCEEDING 125 PSI. *The operating pressure can be increased on the face of the booster pump by turning the hex screw clockwise.*

4. Connect the concentrate 3/8" tubing (waste) line to drain.
5. Plug the booster pump transformer into a power supply of 110 volts 60 Hz.
6. This system has been designed with an auto-flush restrictor. This restrictor automatically flushes the reverse osmosis system for 30 seconds every time it starts up and once every hour when the system is producing water.



NOTE: THE TANK PRESSURE SWITCH WILL SHUT THE SYSTEM OFF AUTOMATICALLY WHEN THE BLADDER TANK IS FULL.

7. The sediment filter and carbon must be serviced regularly for optimal performance. The filters and water quality should be checked every two weeks minimum.
8. Dispose of the product water until the conductivity of the product water reaches your desired level. Use any TDS or Conductivity meter to monitor the product water quality. A minimum quality of 96% NaCl rejection is recommended.



NOTE: ANY CHLORINE EXPOSURE WILL DAMAGE THE MEMBRANE PERMANENTLY.

9. This system has been factory wired and preset with a pressure switch at 20 - 40 psi, which is only to be used with a pressurized bladder tank. If using an atmospheric storage tank, a float switch will be required to turn the system on and off.

MEMBRANE ELEMENTS

L1 - Series Reverse Osmosis Systems equipped with Thin Film Composite (TFC) HF4 Extra Low Energy membranes, unless otherwise specified. General membrane element performance characteristics are listed below.

HF4 – Extra Low Energy Membranes

Operating Limits

■ Membrane Type:	Polyamide Thin-Film Composite	■ pH Range, Short Term Cleaning (30 Min.):	1 – 13
■ Maximum Operating Temperature:	113°F (45°C)	■ Maximum Feed Silt Density Index:	5
■ Maximum Operating Pressure:	600 psi (41 bar)	■ Chlorine Tolerance:	0 ppm
■ pH Range, Continuous Operation*:	2 – 11		

* Maximum temperature for continuous operations above pH10 is 95° F (35°c)

Product Specifications

Part Number	Description	Applied Pressure psi (bar)	Permeate Flow Rate gpd (m3/d)	Nominal Salt Rejection (%)	Part Number	Description	Applied Pressure psi (bar)	Permeate Flow Rate gpd (m3/d)	Nominal Salt Rejection (%)
200386	HF4 – 2514	100 (6.89)	225 (0.85)	99.0	200389	HF4 – 4014	100 (6.89)	600 (2.27)	99.0
200387	HF4 – 2521	100 (6.89)	400 (1.51)	99.0	200390	HF4 – 4021	100 (6.89)	1000 (3.79)	99.0
200388	HF4 – 2540	100 (6.89)	850 (3.22)	99.0	200391	HF4 – 4040	100 (6.89)	2500 (9.46)	99.0

Test Parameters: 550 TDS Filtered (5 Micron), De-Chlorinated, Municipal Feed Water, 77 Degrees F, 15% Permeate Recovery, 6.5 - 7.0 pH Range, at the Specified Operating Pressure. Data Taken After 30 Minutes of Operation. Maximum Pressure drop for each element is 13 psi. Minimum salt rejection is 96%. Permeate flow for individual elements may vary +/- 20%.

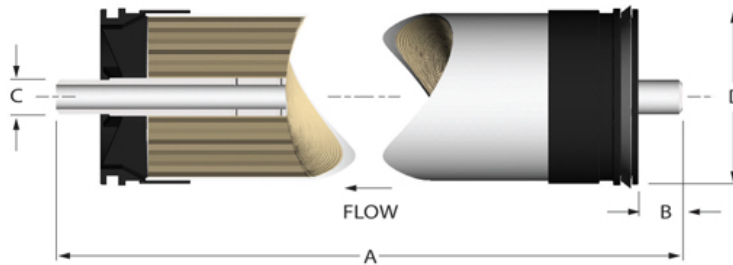

Dimensions inch (mm)

Description	A	B	C	D	Description	A	B	C	D
HF4 – 2514	14 (355.6)	1.1 (27.94)	0.75 (19.05)	2.4 (60.96)	HF4 – 4014	14 (355.6)	1.1 (27.94)	0.75 (19.05)	3.95 (100.3)
HF4 – 2521	21 (533.4)	1.1 (27.94)	0.75 (19.05)	2.4 (60.96)	HF4 – 4021	21 (533.4)	1.1 (27.94)	0.75 (19.05)	3.95 (100.3)
HF4 – 2540	40 (1016.0)	1.1 (27.94)	0.75 (19.05)	2.4 (60.96)	HF4 – 4040	40 (1016.0)	1.1 (27.94)	0.75 (19.05)	3.95 (100.3)

Under certain conditions, the presence of free chlorine and other oxidizing agents will cause premature membrane failure. Since oxidation damage is not covered under warranty, the manufacturer recommends removing residual free chlorine by pretreatment prior to membrane exposure. Wet tested membrane elements must be kept sealed and moist when in storage. Drying out may occur and damage the membrane permanently. Prevent elements from freezing or being exposed to direct sunlight. Wet tested elements are vacuum sealed in a polyethylene bag containing AXEON M100 Membrane Preservative and then packaged in a cardboard box. Discard the permeate for the first twenty-four hours of operation. The permeate flow (product water flow) varies with feed water temperature. For membrane warranty information, please contact the manufacturer.

The manufacturer believes the information and data contained herein to be accurate and useful. The information and data are offered in good faith, but without guarantee, as conditions and methods of use of products are beyond the manufacturer's control. The manufacturer assumes no liability for results obtained or damages incurred through the application of the presented information and data. It is the user's responsibility to determine the appropriateness of these products for the user's specific end uses.

SYSTEM IDENTIFICATION

ISO VIEW
TOP COVER REMOVED FOR CLARITY

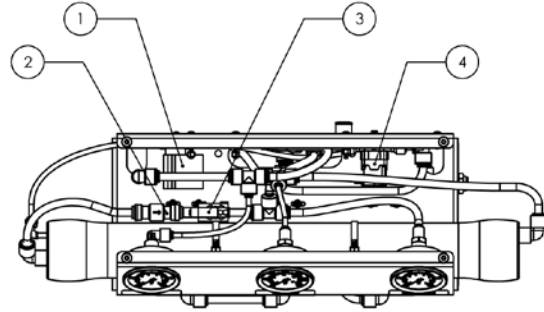
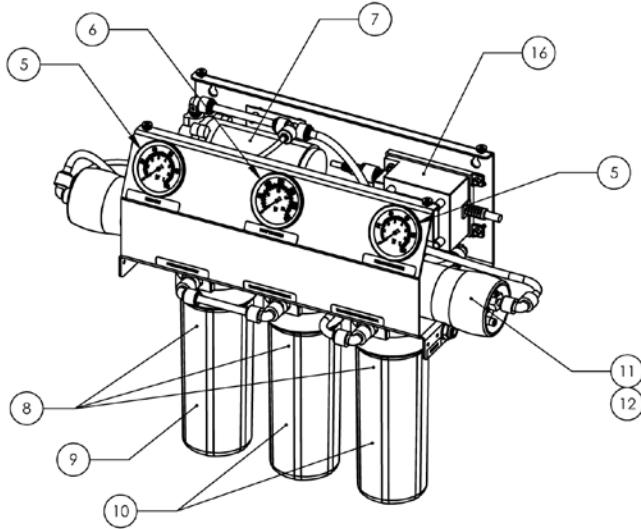

TOP VIEW
TRANSFORMER, MOTOR, AND TOP COVER REMOVED FOR CLARITY

ITEM NO	PART NUMBER	DESCRIPTION	MODEL
1	200772	RESTRICTOR, FIXED, 800 ML/MIN, AUTO FLUSH, 1/4" QC, AQUATEC	200, 300
2	200962	VALVE, CHECK, ACETAL, 3/8" QC X 3/8" QC, JG	200, 300
3	200771	SWITCH, TANK, PRESSURE, 20-40 PSI, 3/8" QC, AQUATEC	200, 300
4	207974	VALVE, SOLENOID, 3/8" QC, 24V, INTERELEKTRIK	200, 300
5	204165	GAUGE, PM, GLY FILL, 0-100 PSI/BAR, 2.5" DIA, 1/4" MNPT, AXEON	200, 300
6	200904	GAUGE, PM, GLY FILL, 0-300 PSI/BAR, 2.5" DIA, 1/4" MNPT, AXEON	200, 300
7	200768	PUMP, BOOSTER, 8800, 3/8" QC, AQUATEC	200
7	207039	PUMP, BOOSTER, 5800, 3.5GPM, 50PSI, 12V, 3/8" JG, AQUATEC	300
8	207282	HOUSING, FILTER, WHT/WHT, 2.5" X 10", SGL O-RING, NPR, 3/8" FNPT, AXEON	200, 300
9	200621	CARTRIDGE, SEDIMENT, POLYPRO, 2.5" X 10", 5 MIC, SDF-25-1005, AXEON	200, 300
10	200658	CARTRIDGE, CARBON, BLOCK, 2.5" X 10", 10 MIC, CBF-25-1010, AXEON	200, 300
11	208122	HOUSING, MEMBRANE, FRP, 2514, 1/4" P X 1/4" C FNPT	200
11	204229	HOUSING, MEMBRANE, FRP, 2521, 1/4" P X 1/4" C FNPT	300
12	200386	MEMBRANE, HF4, 2514, DRY, AXEON	200
12	200387	MEMBRANE, HF4, 2521, DRY, AXEON	300
13	202862	PLUG, 1/4", GRAY	200, 300
14	207702	O-RING, EPDM, 1/2", FRP-300E	200, 300
15	207701	O-RING, EPDM, 2.5", FRP-300E	200, 300
16	207704	CLAMP, TRUE-LOCK, 304SS, 2.5", FRP-300E	200, 300
17	207917	TRANSFORMER, 110V 60HZ 24VAC, 4.0 AMP, TDC	200, 300
17	207918	TRANSFORMER, 230V 50HZ 24VAC, 4.0 AMP, TDC	200, 300
18	206806	WRENCH, HOUSING, FILTER, SGL O-RING, 360 DEG, 2.5", SLIM LINE, PENTEK	200, 300
19	207705	SCREW, TRUE-LOCK, M6X25, 316SS, FASTENER, FRP-300E	200, 300

MEMBRANE INSTALLATION, REMOVAL AND REPLACEMENT

Installation and replacing membranes in the pressure vessels is an easy process if you have the proper information and tools at hand. Please refer to the following instructions when removing and replacing membrane elements:



WARNING: ALL PRESSURE GAUGES MUST READ ZERO BEFORE PROCEEDING. BEFORE ATTEMPTING, DISCONNECT THE POWER FROM THE SYSTEM AND BLEED ALL WATER PRESSURE FROM THE SYSTEM.

1. Remove the end cap from the right (feed water) side of the membrane housings. This is done by removing the two half-moon retaining disks using a #5 Allen wrench, the end plug should then freely slide out of the pressure vessel.
2. Remove the membrane bag containing the membrane element from the shipping box. The membrane should be contained within a plastic oxygen barrier bag.

NOTE: WEAR GLOVES FOR THE FOLLOWING STEPS IN ORDER NOT TO CONTAMINATE THE MEMBRANE.

3. Cut the bag open as close as possible to the seal at one end of the bag, so the bag may be re-used if necessary.
4. Make sure that all parts are clean and free from dirt. Examine the brine seal, and permeate tube for nicks or cuts. Replace the O-rings or brine seal if damaged.
5. Flow directions should be observed for installation of the membrane element into the pressure vessels.

REPLACING THE MEMBRANE ELEMENT:



WARNING: THE BRINE SEAL MUST BE IN THE SAME POSITION AS IT WAS FOR FACTORY PRE-INSTALLED MEMBRANE ELEMENT. THE BRINE SEAL IS A

RUBBER SEAL THAT PROTRUDES ON ONE SIDE OF THE MEMBRANE AND IS ALWAYS ON THE FEED SIDE OF THE MEMBRANE ELEMENT. FOR L1 SERIES RO SYSTEMS THE BRINE SEAL SHOULD BE ON THE RIGHT SIDE OF THE MEMBRANE HOUSING.

1. Remove membrane element from the right (feed water) side of the membrane housing. Long nose pliers may be necessary to pull the old membrane element out of the membrane element housing.
2. Lubricate the brine seal and o-rings with a non-petroleum based lubricant, such as Dow Corning® 111. Do not use a petroleum-based lubricant.
3. Install membrane through the right side (feed water) of the membrane housing with brine seal located on the feed water side.
4. With a smooth and constant motion, push the membrane element into the housing so the brine seal enters the housing without coming out of the brine seal groove.
5. Re-install the end plug (6, Figure 1.A) on the right side by gently twisting the end cap, while pushing it onto the housing. Ensure that you do not pinch or fatigue any o-rings while re-installing the end plug. Push the end plug on until the outer diameter of the plug is flush with the outer diameter of the pressure vessel.
6. Insert the two half-moon retaining disks until they are fully seated. Subsequently fasten using a #5 Allen wrench.
7. Reconnect any fittings that may have been disconnected when the membrane pressure vessels were disassembled.
8. To Start-Up the system, please refer to the Initial Start-Up section of this manual.



CAUTION: WET MEMBRANES ARE SHIPPED IN A PRESERVATIVE SOLUTION. THE MEMBRANES MUST BE FLUSHED FOR AT LEAST 30 MINUTES TO REMOVE THE PRESERVATIVE FROM THE MEMBRANE. DISCARD ALL OF THE PERMEATE, WHICH IS PRODUCED DURING THE FLUSH PERIOD.

OPERATION DO'S AND DON'TS

DO:

- Change the cartridge filters regularly
- Monitor the system and keep a daily log
- Run the system as much as possible on a continuous basis
- Always feed the pump with filtered water

DON'T

- Permit chlorine to enter membrane housing with the feed water
- Shut down the system for extended periods
- Operate the system with insufficient feed flow
- Operate the pump dry

SPECIFICATIONS

Product Specifications		
	L1-200	L1-300
Design		
Configuration	Single Pass	Single Pass
Feed Water Source (ppm)	TDS <1000	TDS <1000
Standard Recovery*	40%	50%
Rejection and Flow Rates		
Nominal Salt Rejection	98.5%	98.5%
Permeate Flow* (gpm / lpm)	0.14 / 0.53	0.21 / 0.79
Concentrate Flow (gpm / lpm)	0.21 / 0.79	0.21 / 0.79
Connections		
Feed (in)	3/8 Tube	3/8 Tube
Permeate (in)	3/8 Tube	3/8 Tube
Concentrate (in)	3/8 Tube	3/8 Tube
Membranes		
Membrane Per Vessel	1	1
Membrane Quantity	1	1
Membrane Size	2514	2521
Vessels		
Vessel Array	1	1
Vessel Quantity	1	1
Pumps		
Pump Type	Aquatec 5800	Aquatec 5800
Motor (hp / kw)	N/A	N/A
Electrical		
Standard Voltage	110V, 60Hz, 1Ph, 1.0A	110V, 60Hz, 1Ph 1.0A
Voltage Options	220V, 50Hz, 1Ph, 0.5A	220V, 50Hz, 1Ph, 0.5A
System Dimensions		
L x W x H (in / cm)	9 x 20 x 19 / 22.9 x 50.8 x 48.3	9 x 27 x 19 / 22.9 x 68.6 x 48.3
Weight (lb / kg)	42 / 19.1	50 / 22.7

* Product flow and recovery rates are based on feedwater conditions of 550 ppm TDS at 77°F. Treatment ability of the RO system is dependent on feed water quality. Higher TDS and/or lower temperatures will reduce product flow. Performance projections should be run for each installation.

Operating Limits

Design Temperature	77°F	Max. Turbidity NTU ^	1
Max. Feed Temperature	85°F	Max. Free Chlorine ppm	0
Min. Feed Temperature	40°F	Max. TDS ppm	1,000
Max. Ambient Temperature	120°F	Max. Hardness GPG ^^	1
Min. Ambient Temperature	40°F	Max. pH (Continuous)	11
Max. Feed Pressure psi	85	Min. pH (Continuous)	3
Min. Feed Pressure psi	45	Max. pH (Cleaning 30 Min.)	12
Max. Operating Pressure psi	120	Min. pH (Cleaning 30 Min.)	2
Max. SDI Rating	<3		

Test Parameters: Static pressure test for 5 minutes.

^ Appropriate filtration must be installed in order to prevent premature membrane fouling.

^^ Scale prevention measures must be taken to prolong membrane life.

OPERATION AND MAINTENANCE

The reverse osmosis process causes the concentration of impurities. The impurities may precipitate (come out of solution) when their concentration reaches saturation levels.



NOTE: PRECIPITATION CAN SCALE OR FOUL MEMBRANES AND MUST BE PREVENTED.

1. Periodically observe the quality and quantity of product water from the system.



NOTE: CHECK THE FEED WATER PRESSURE GOING INTO THE REVERSE OSMOSIS MEMBRANE, A SIGNIFICANT DROP IN PRESSURE COULD INDICATE A FOULED PRE-FILTER.

2. A 20% increase in TDS when checking the permeate water indicates possible membrane damage, and the membrane may need to be replaced.
3. It is suggested that a hand held TDS digital meter is used once per week to monitor the water quality.



NOTE: IF THE TDS OF THE FEED WATER EXCEEDS 1000 PPM, A LARGER FLOW RESTRICTOR SHOULD BE USED TO EXTEND THE MEMBRANE LIFE.

4. It is important to maintain and/or replace the carbon block regularly since the Thin Film Composite membranes are chlorine sensitive. Irreversible damage will occur with any chlorine present in the feed water. For additional information, please review the manufacturer's membrane specification sheets.
5. The product line has a one way check valve installed. The check valve should be checked regularly and replaced if it is not properly sealing.
6. Keep the feed water temperature above 4°C (36°F).



NOTE: EXTREMELY COLD FEED WATER WILL LOWER THE PRODUCT WATER OUTPUT AND INCREASE PUMP PRESSURE.



PREPARING UNIT FOR STORAGE OR SHIPMENT

Prior to shipping or storing your system, the system should be cleaned with an appropriate cleaner, flushed with water and protected from biological attack with an appropriate solution for membrane elements. The membrane housing(s) and plumbing lines of the system must be completely drained. Any water remaining in the plumbing of a system may freeze, causing serious damage.

Preparing system for storage:

1. Totally fill membrane elements in the membrane housing with 2 % M-100 solution, venting the air outside of the pressure vessels. Use the overflow technique: circulate the M-100 solution in such a way that the remaining air in the system is minimized after the recirculation is completed.
2. Check the pH once a week. When the pH becomes 3 or lower, change the preservation solution.
3. Repeat this process at least once a month.

During the shutdown period, the plant must be kept frost-free, or the temperature must not exceed 113°F (45°C).

Preparing unit for shipment:

4. Disconnect the inlet, concentrate, pre-filter, and permeate plumbing.
5. Drain all water from the pre-filter cartridge housings by unscrewing the housings, removing the pre-filter cartridges, and drain the water from the housings.
6. Disconnect the tubing from the connectors on the permeate and concentrate inlets and outlets.

Allow the system to drain for a minimum of eight hours or until the opened ports quit dripping.

After draining is complete, reconnect all of the plumbing.

REVERSE OSMOSIS TROUBLESHOOTING

SYMPTOMS	POSSIBLE CAUSES	CORRECTIVE ACTION
Low Inlet Pressure	Low supply pressure	Increase inlet pressure
	Cartridge filters plugged	Change filters
	Solenoid valve malfunction	Replace sol. valve and/or coil
	Motor may not be drawing correct current	Use clamp-on amp meter to check the motor amp draw.
	Leaks	Fix any visible leaks
Low Permeate Flow	Cold feed water	See temperature correction sheet
	Low operating pressure	See low inlet pressure
	Defective membrane brine seal	Inspect and/or replace brine seal
	Fouled or scaled membrane	Clean membranes
High permeate flow	Damaged product tube o-rings	Inspect and/or replace
	Damaged or oxidized membrane	Replace membrane
	Exceeding maximum feed water temperature	See temperature correction sheet
Poor permeate quality	Low operating pressure	See low inlet pressure
	Damage product tube o-rings	Inspect and/or replace
	Damaged or oxidized membrane	Replace membrane
Membrane fouling	Metal Oxide Fouling	Improve pretreatment to remove metals. Clean with acid cleaners.
	Colloidal Fouling	Optimize pretreatment for colloid removal. Clean with high pH anionic cleaners.
	Scaling (CaSO ₄ , CaSO ₃ , BaSO ₄ , SiO ₂)	Increase acid addition and antiscalant dosage for CaVO ₃ and CaCO ₄ . Reduce recovery. Clean with acid cleaners
	Biological Fouling	Shock dosage of Sodium Bi-Sulfate. Continuous feed of Sodium Bi-Sulfate at reduced pH. Chlorination and de-chlorination. Replace cartridge filters.
	Organic Fouling	Activated Carbon or other pretreatment. Clean with high pH cleaner.
	Chlorine Oxidation	Check Chlorine feed equipment and de-chlorination system.
	Abrasion of membrane by Crystalline Material	Improve pretreatment. Check all filters for media leakage.

ABNORMAL PERMEATE FLOW

Permeate flow should be within 20% of the rated production, after correcting the feed water temperatures above or below 77°F. Check your permeate flow meter to determine the permeate flow rate.



NOTE: TO DETERMINE THE TEMPERATURE CORRECTION FACTOR, LOCATE THE TEMPERATURE CORRECTION TABLE IN THIS USER'S MANUAL AND FOLLOW THE DIRECTIONS.

TEMPERATURE CORRECTION FACTORS FOR MEMBRANE

Find the temperature correction factor (TCF) from the table below. Divide the rated permeate flow at 77°F by the temperature correction factor. The result is the permeate flow at the desired temperature. (See example on the next page)

Temperature °F (°C)	Temperature Correction Factor	Temperature °F (°C)	Temperature Correction Factor	Temperature °F (°C)	Temperature Correction Factor	Temperature °F (°C)	Temperature Correction Factor	Temperature °F (°C)	Temperature Correction Factor
50.0 (10.0)	1.711	57.2 (14.0)	1.475	64.4 (18.0)	1.276	71.6 (22.0)	1.109	78.8 (26.0)	0.971
50.2 (10.1)	1.705	57.4 (14.1)	1.469	64.6 (18.1)	1.272	71.8 (22.1)	1.105	79.0 (26.1)	0.968
50.4 (10.2)	1.698	57.6 (14.2)	1.464	64.8 (18.2)	1.267	72.0 (22.2)	1.101	79.2 (26.2)	0.965
50.5 (10.3)	1.692	57.7 (14.3)	1.459	64.9 (18.3)	1.262	72.1 (22.3)	1.097	79.3 (26.3)	0.962
50.7 (10.4)	1.686	57.9 (14.4)	1.453	65.1 (18.4)	1.258	72.3 (22.4)	1.093	79.5 (26.4)	0.959
50.9 (10.5)	1.679	58.1 (14.5)	1.448	65.3 (18.5)	1.254	72.5 (22.5)	1.090	79.7 (26.5)	0.957
51.1 (10.6)	1.673	58.3 (14.6)	1.443	65.5 (18.6)	1.249	72.7 (22.6)	1.086	79.9 (26.6)	0.954
51.3 (10.7)	1.667	58.5 (14.7)	1.437	65.7 (18.7)	1.245	72.9 (22.7)	1.082	80.1 (26.7)	0.951
51.4 (10.8)	1.660	58.6 (14.8)	1.432	65.8 (18.8)	1.240	73.0 (22.8)	1.078	80.2 (26.8)	0.948
51.6 (10.9)	1.654	58.8 (14.9)	1.427	66.0 (18.9)	1.236	73.2 (22.9)	1.075	80.4 (26.9)	0.945
51.8 (11.0)	1.648	59.0 (15.0)	1.422	66.2 (19.0)	1.232	73.4 (23.0)	1.071	80.6 (27.0)	0.943
52.0 (11.1)	1.642	59.2 (15.1)	1.417	66.4 (19.1)	1.227	73.6 (23.1)	1.067	80.8 (27.1)	0.940
52.2 (11.2)	1.636	59.4 (15.2)	1.411	66.6 (19.2)	1.223	73.8 (23.2)	1.064	81.0 (27.2)	0.937
52.3 (11.3)	1.630	59.5 (15.3)	1.406	66.7 (19.3)	1.219	73.9 (23.3)	1.060	81.1 (27.3)	0.934
52.5 (11.4)	1.624	59.7 (15.4)	1.401	66.9 (19.4)	1.214	74.1 (23.4)	1.056	81.3 (27.4)	0.932
52.7 (11.5)	1.618	59.9 (15.5)	1.396	67.1 (19.5)	1.210	74.3 (23.5)	1.053	81.5 (27.5)	0.929
52.9 (11.6)	1.611	60.1 (15.6)	1.391	67.3 (19.6)	1.206	74.5 (23.6)	1.049	81.7 (27.6)	0.926
53.1 (11.7)	1.605	60.3 (15.7)	1.386	67.5 (19.7)	1.201	74.7 (23.7)	1.045	81.9 (27.7)	0.924
53.2 (11.8)	1.600	60.4 (15.8)	1.381	67.6 (19.8)	1.197	74.8 (23.8)	1.042	82.0 (27.8)	0.921
53.4 (11.9)	1.594	60.6 (15.9)	1.376	67.8 (19.9)	1.193	75.0 (23.9)	1.038	82.2 (27.9)	0.918
53.6 (12.0)	1.588	60.8 (16.0)	1.371	68.0 (20.0)	1.189	75.2 (24.0)	1.035	82.4 (28.0)	0.915
53.8 (12.1)	1.582	61.0 (16.1)	1.366	68.2 (20.1)	1.185	75.4 (24.1)	1.031	82.6 (28.1)	0.913
54.0 (12.2)	1.576	61.2 (16.2)	1.361	68.4 (20.2)	1.180	75.6 (24.2)	1.028	82.8 (28.2)	0.910
54.1 (12.3)	1.570	61.3 (16.3)	1.356	68.5 (20.3)	1.176	75.7 (24.3)	1.024	82.9 (28.3)	0.908
54.3 (12.4)	1.564	61.5 (16.4)	1.351	68.7 (20.4)	1.172	75.9 (24.4)	1.021	83.1 (28.4)	0.905
54.5 (12.5)	1.558	61.7 (16.5)	1.347	68.9 (20.5)	1.168	76.1 (24.5)	1.017	83.3 (28.5)	0.902
54.7 (12.6)	1.553	61.9 (16.6)	1.342	69.1 (20.6)	1.164	76.3 (24.6)	1.014	83.5 (28.6)	0.900
54.9 (12.7)	1.547	62.1 (16.7)	1.337	69.3 (20.7)	1.160	76.5 (24.7)	1.010	83.7 (28.7)	0.897
55.0 (12.8)	1.541	62.2 (16.8)	1.332	69.4 (20.8)	1.156	76.6 (24.8)	1.007	83.8 (28.8)	0.894
55.2 (12.9)	1.536	62.4 (16.9)	1.327	69.6 (20.9)	1.152	76.8 (24.9)	1.003	84.0 (28.9)	0.892
55.4 (13.0)	1.530	62.6 (17.0)	1.323	69.8 (21.0)	1.148	77.0 (25.0)	1.000	84.2 (29.0)	0.889
55.6 (13.1)	1.524	62.8 (17.1)	1.318	70.0 (21.1)	1.144	77.2 (25.1)	0.997	84.4 (29.1)	0.887
55.8 (13.2)	1.519	63.0 (17.2)	1.313	70.2 (21.2)	1.140	77.4 (25.2)	0.994	84.6 (29.2)	0.884
55.9 (13.3)	1.513	63.1 (17.3)	1.308	70.3 (21.3)	1.136	77.5 (25.3)	0.991	84.7 (29.3)	0.882
56.1 (13.4)	1.508	63.3 (17.4)	1.304	70.5 (21.4)	1.132	77.7 (25.4)	0.988	84.9 (29.4)	0.879
56.3 (13.5)	1.502	63.5 (17.5)	1.299	70.7 (21.5)	1.128	77.9 (25.5)	0.985	85.1 (29.5)	0.877
56.5 (13.6)	1.496	63.7 (17.6)	1.294	70.9 (21.6)	1.124	78.1 (25.6)	0.982	85.3 (29.6)	0.874
56.7 (13.7)	1.491	63.9 (17.7)	1.290	71.1 (21.7)	1.120	78.3 (25.7)	0.979	85.5 (29.7)	0.871
56.8 (13.8)	1.486	64.0 (17.8)	1.285	71.2 (21.8)	1.116	78.4 (25.8)	0.977	85.6 (29.8)	0.869
57.0 (13.9)	1.480	64.2 (17.9)	1.281	71.4 (21.9)	1.112	78.6 (25.9)	0.974	85.8 (29.9)	0.866

T = [°C x 9/5] + 32

Corrected Flow Rate = [Measured Flow Rate] * [TCF @ Feed Water Temp.]

If a system is rated to produce 5 gpm of permeate water @ 77° F, the same system will produce more water at a higher temperature. It will also produce less water at a lower temperature. Use the temperature correction table to obtain the correct flow.

Example:

5 gpm @ 59° F ($5 \div 1.42 = 3.52$ gpm)

5 gpm @ 77° F ($5 \div 1 = 5$ gpm)

5 gpm @ 84° F ($5 \div 0.89 = 5.62$ gpm)

SERVICE ASSISTANCE

If service assistance is required, please complete the following process:

Contact your local dealer or distributor. Prior to making the call, have the following information available: system installation date, serial number, daily log sheets, current operating parameters (e.g. flow, operating pressures, pH, etc.) and a detailed description of the problem.

OPERATION LOG

Company: _____	Date of Start-Up: _____
Location: _____	Date of Last Cleaning: _____
Week Of: _____	
System Serial #: _____	

DATE					
TIME					
HOUR OF OPERATION					
FILTER INLET PRESSURE (PSI)					
FILTER OUTLET PRESSURE (PSI)					
CONCENTRATE PRESSURE (PSI)					
PUMP DISCHARGE PRESSURE (PSI)					
FEED FLOW (GPM)					
PERMEATE FLOW (GPM)					
CONCENTRATE FLOW (GPM)					
RECOVERY %					
FEED TEMPERATURE					
FEED TDS (PPM)					
PERMEATE TDS (PPM)					
REJECTION %					
FEED PH					
PERMEATE PH					
SCALE INHIBITOR FEED (PPM)					
IRON (mg/L)					
FREE CHLORINE (mg/L)					
HARDNESS (GPG CaCO ₃)					

SYSTEM DRAWING

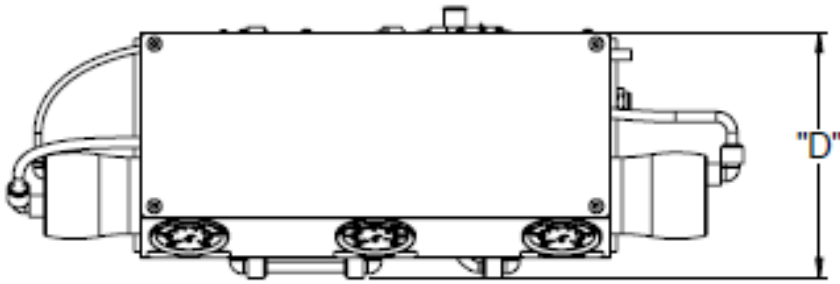

DIMMENSIONS	L1-200	L1-300
"A" DIM	20.17	26.67
"B" DIM	17.00	17.00
"C" DIM	18.92	18.92
"D" DIM	9.05	9.05

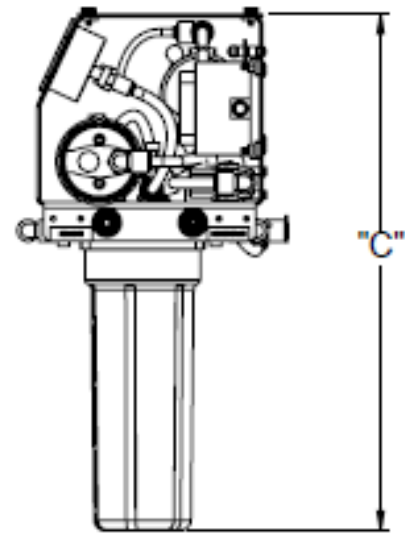
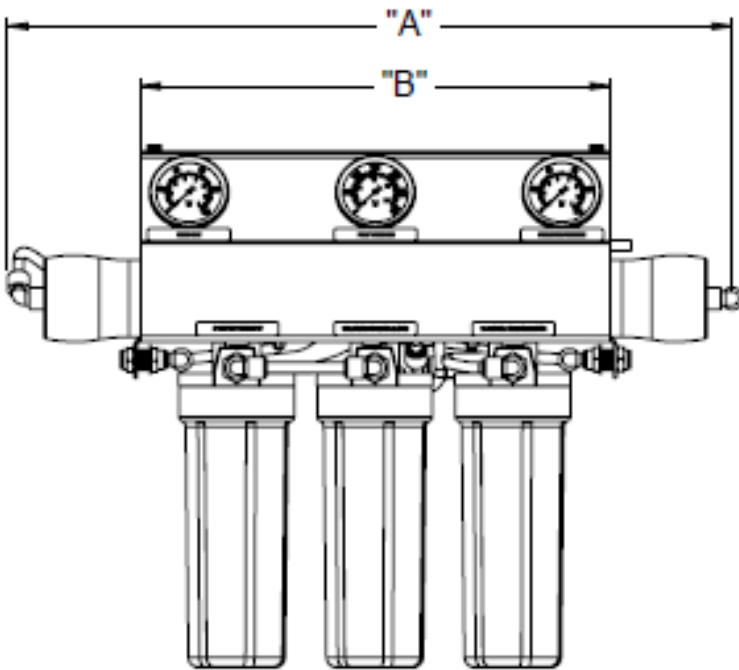

L1-300 FLOW DIAGRAM

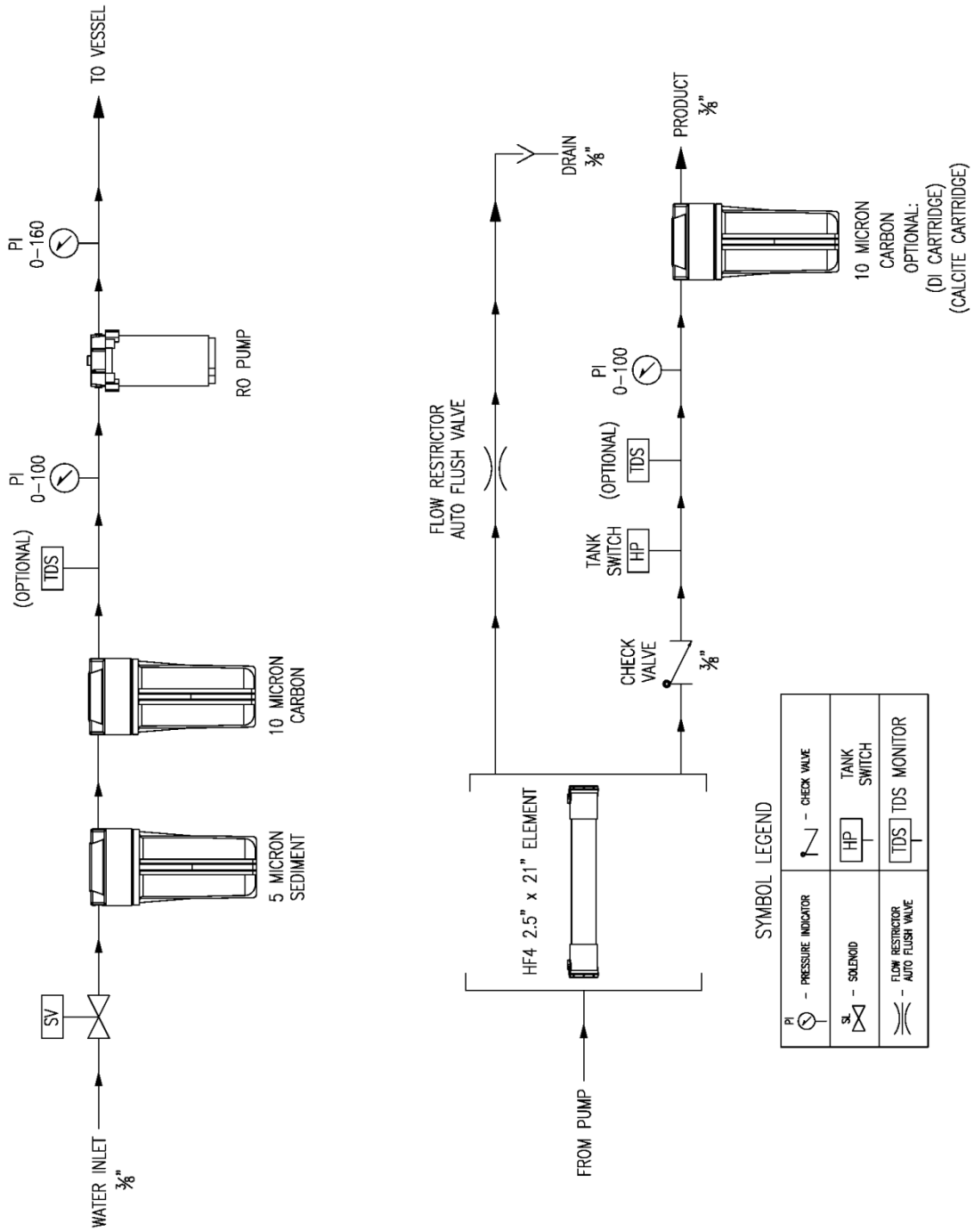

SYMBOL LEGEND

PI	- PRESSURE INDICATOR		- CHECK VALVE
SV	- SOLENOID	HP	TANK SWITCH
	FLOW RESTRICTOR	TDS	TDS MONITOR
	- AUTO FLUSH VALVE		

L1 - SERIES ELECTRICAL SCHEMATIC 110V/60HZ

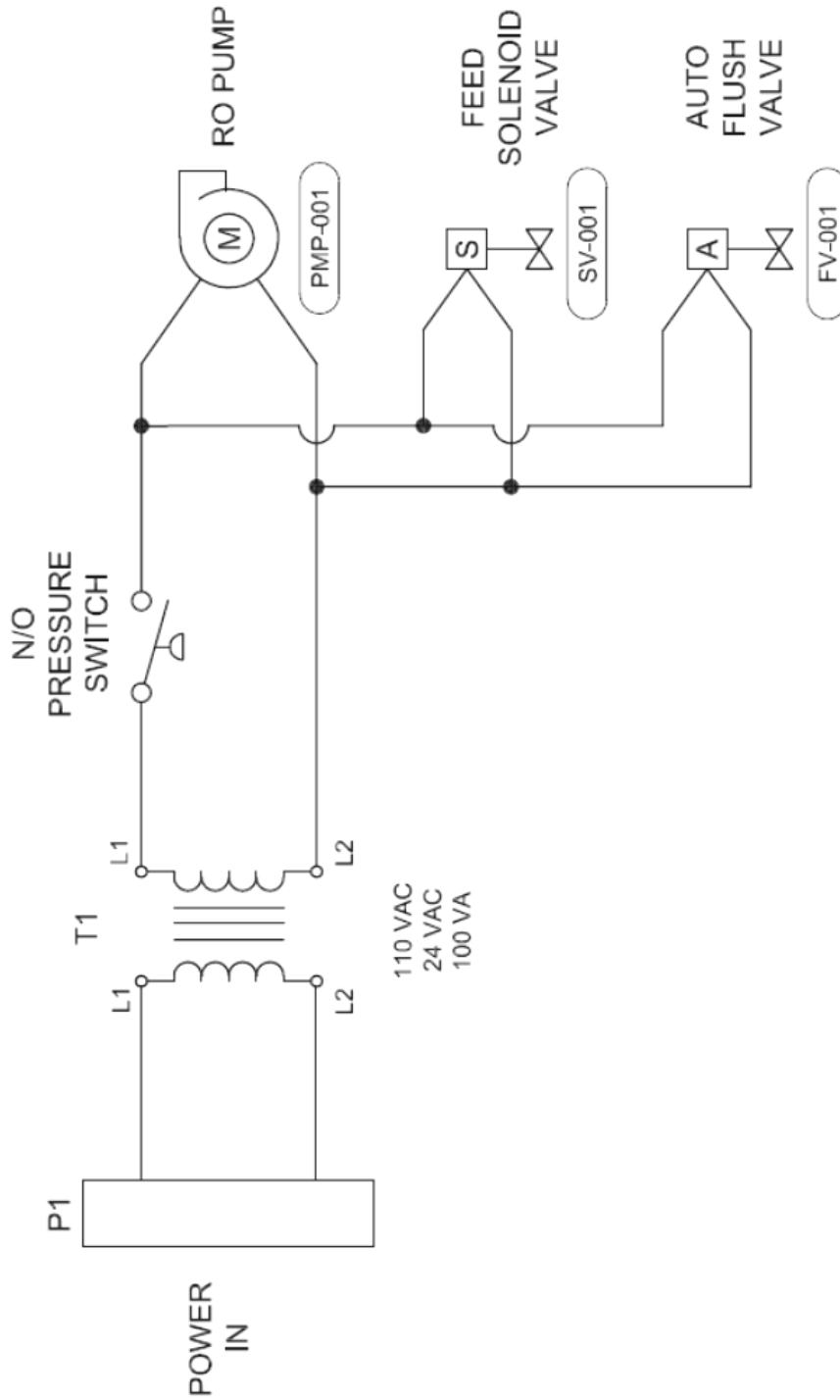

L1 - SERIES ELECTRICAL SCHEMATIC 220V/50HZ

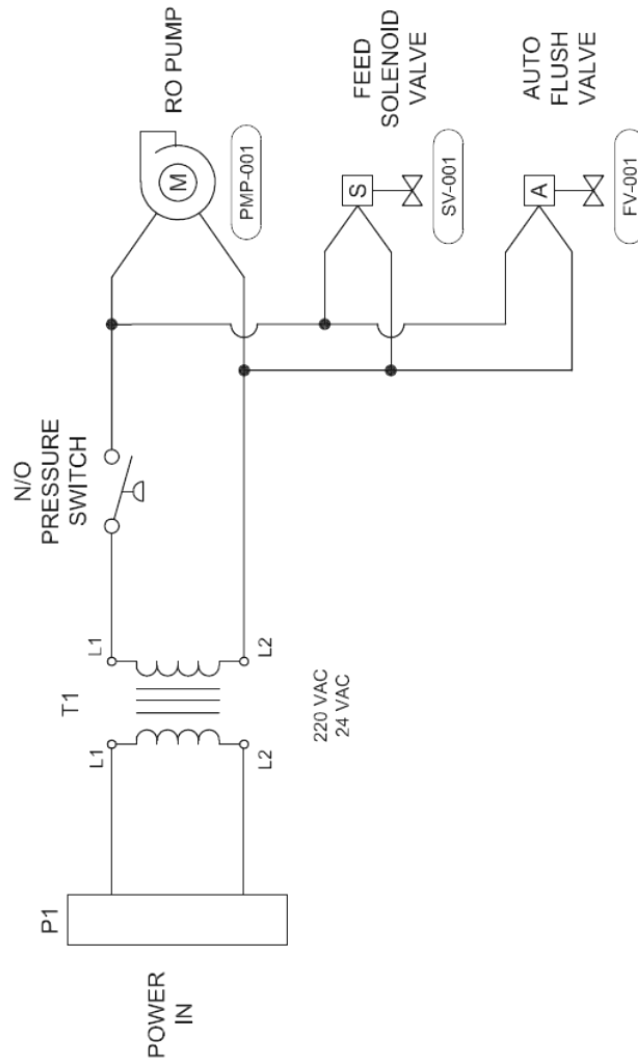

REVERSE OSMOSIS SYSTEM WARRANTY

One-Year Limited Warranty

Warranty Terms

Subject to the terms and conditions set forth hereinafter, AXEON Water Technologies (hereafter "AXEON") warrants to the original purchaser (hereafter the "Customer") that the systems and products manufactured by AXEON are free from defects in material and in workmanship for twelve (12) months from the Warranty Commencement Date (as defined below) only when used strictly in accordance with the applicable operating instructions and within the range of the operating conditions specified by AXEON for each such product.

This Warranty does not extend to systems, equipment, or components manufactured by others, nor to systems, equipment, or components manufactured by others and distributed by AXEON. This Warranty does not extend to equipment or components manufactured by others which have been incorporated into an AXEON product but, if allowable, AXEON hereby assigns, without warranty, to the Customer its interest, if any, under any warranty made by the manufacturer of such equipment or component. This Warranty does not cover disposable items such as fuses, o-rings, regeneration materials/chemicals, or other such disposable items, which must be replaced periodically under the normal and foreseeable operating conditions of the goods warranted hereby.

Warranty Commencement Date

The Warranty Commencement Date for each AXEON product shall be the later of the date of: (1) receipt by the Customer, or (2) the date of installation at the Customer's premises provided that such installation must occur within three (3) months of shipment from the AXEON's manufacturing facility in Temecula, California. In no event shall the Warranty Commencement Date exceed three (3) months from the shipment from AXEON's manufacturing facility. The Customer shall provide proof of purchase in order to exercise rights granted under this Warranty. If requested by AXEON, the Customer must also provide proof of the installation date. Proof of installation shall be returned by Customer to AXEON within thirty (30) days after installation by virtue of supplying a Warranty Validation Card supplied with each AXEON product fully completed and signed in ink by Customer and the authorized installer of the product.

Warranty Service

AXEON'S OBLIGATION UNDER THIS WARRANTY IS LIMITED TO THE REPAIR OR REPLACEMENT (AT AXEON'S SOLE DISCRETION) OF ANY PRODUCT, OR

COMPONENT THEREOF, PROVED TO BE DEFECTIVE IN MATERIAL OR WORKMANSHIP WITHIN THE COVERED WARRANTY PERIOD.

The Customer, at the Customer's risk and expense, shall be responsible for returning such product or component, only after obtaining a Return Goods Authorization (RGA) number from AXEON, arranging for freight prepaid, and in conformance with any special packaging and shipping instructions set forth on the operation documentation or RGA instructions, or as otherwise reasonably required, to AXEON's address set forth below, together with (1) RGA number issued by AXEON at Customer's request; (2) proof of purchase and, if necessary, proof of installation date; (3) a Return Goods Authorization Form; (4) a description of the suspected defects; (5) the serial number of the AXEON product alleged to be defective; and (6) a description of the type of water and pretreatment equipment which has been utilized in connection with the product, if any. AXEON shall, in AXEON's reasonable discretion, be the sole judge of whether a returned product or component is defective in material or workmanship. Required or replaced products or components shall be returned surface freight. In genuine emergency situations, AXEON will (at AXEON's sole discretion) forward replacement parts to Customer without waiting for authorized return of the questionable part(s). In such cases, Customer will issue a purchase order or other payment guarantee prior to shipment. If the returned part is found to have been misused or abused, or the defective part is not received by AXEON within thirty (30) days; the Customer will be invoiced for the replacement part(s) provided. This Warranty does not cover or include labor and/or travel to the Customer's premise or location or any other location. Charges of \$1000 per day plus associated travel expenses will be incurred by the Customer in providing the Warranty Service at any location other than AXEON's main headquarters; that is if AXEON deems that the product is not covered by said Warranty. AXEON reserves the right to precondition such travel to Customer's premises upon prepayment of AXEON's anticipated costs of attending such premises.

Voidability of Warranty

This Warranty shall be void and unenforceable as to any AXEON product which has been damaged by accident, mishandling, abuse or has been repaired, modified, altered, disassembled or otherwise tampered with by anyone other than AXEON or an authorized AXEON service representative; or, if any replacement parts are not authorized by AXEON have been used, or, the product has not been installed, operated and maintained in strict accordance and adherence with the operating documentation and manuals for such product. Any expressed warranty, or similar representation of performance set forth in the operation documentation for media or resin incorporated into an AXEON product shall be void and unenforceable unless the feed water requirements set forth in the operating documentation for such product are unequivocally and strictly adhered to.

Limitations and Exclusions

THIS WARRANTY AND REMEDIES DESCRIBED HEREIN AND HEREINABOVE ARE EXCLUSIVE AND IN LIEU OF ANY AND ALL OTHER WARRANTY OR REMEDIES, EXPRESSED OR IMPLIED, INCLUDING WITHOUT LIMITATION, ANY IMPLIED WARRANTY OF MERCHANTABILITY OR FITNESS FOR A PARTICULAR PURPOSE. IN NO EVENT SHALL AXEON BE LIABLE FOR ANY CONSEQUENTIAL, INCIDENTAL OR OTHER SIMILAR TYPES OF DAMAGES, FOR DAMAGES FOR THE LOSS OF PRODUCTION OR PROFITS, OR INJURY TO PERSON OR PROPERTY. NO PERSON HAS ANY AUTHORITY TO BIND AXEON TO OTHER THAN WHAT IS SET FORTH ABOVE.

THIS WARRANTY GIVES THE CUSTOMER SPECIFIC LEGAL RIGHTS AND THE CUSTOMER MAY ALSO HAVE OTHER RIGHTS WHICH VARY FROM JURISDICTION TO JURISDICTION. THE PARTIES RECOGNIZE AND AGREE, THAT IN ALL RESPECTS THE LAWS OF THE STATE OF CALIFORNIA SHALL APPLY TO AND SHALL GOVERN ANY INTERPRETATION OR LEGAL SIGNIFICANCE OF THIS DOCUMENT.

NO WARRANTY OR OTHER LIABILITY OF AXEON TO CUSTOMER UNDER THIS AGREEMENT OR OTHERWISE WILL IN ANY EVENT EXCEED THE COST OF REPLACEMENT OF THE APPLICABLE AXEON PRODUCT, PART, OR ACCESSORY THAT IS SUBJECT TO ANY BREACH OF AXEON'S WARRANTY. AXEON WILL NOT BE LIABLE FOR ANY DAMAGE TO ANY PROPERTY OF CUSTOMER OR TO CUSTOMER'S CUSTOMERS FOR ANY CONSEQUENTIAL, INCIDENTAL, OR ECONOMIC LOSS OR COMMERCIAL DAMAGE WHATSOEVER. REMEDIES HEREIN PROVIDED ARE EXPRESSLY MADE THE SOLE AND EXCLUSIVE REMEDIES FOR BREACH OF ANY WARRANTY OR OTHER OBLIGATION HEREUNDER EXPRESS OR IMPLIED OR FROM THE OPERATION OF LAW.