

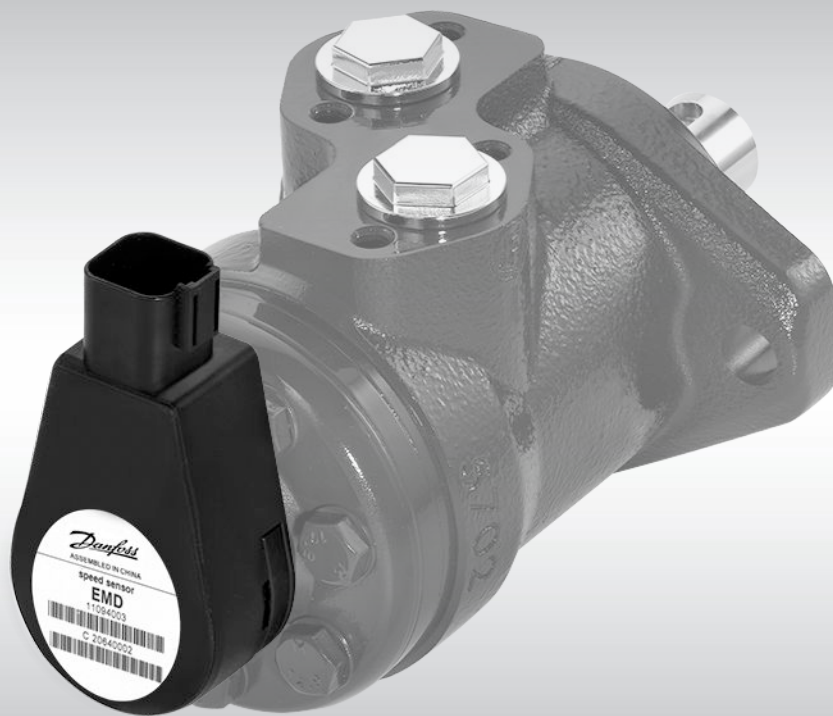

User Manual
Orbital Motor
EMD Speed Sensor



Revision history*Table of revisions*

Date	Changed	Rev
April 2015	CG150 updated to CG150-2	BD
January 2015	Various updates	BC
April 2014	Various updates	BB
March 2014	Converted to Danfoss layout - DITA CMS	BA
May 2012	Conversion Diagram text updated	AB
May 2012	First edition	AA

Contents
Product Overview

Description.....4

General data

EMD Speed Sensor specifications.....5

Signal definition

Pulse mode.....6

Quadrature mode.....6

CAN mode.....6

Filter parameter

Positioning.....8

Product overview

Dimensions.....9

Sensor pinout.....9

Mating connector.....10

Wiring diagram.....10

Conversion diagram.....11

Mounting of EMD Speed Sensor

Mounting of EMD Speed Sensor on LSHT Motors.....12

Configuration of EMD-Speed Sensor to other settings

Connect configuration box.....13

Changing of numbers of pulses/rev in pulse mode.....13

Change of MA-Filter in Pulse mode.....14

Changing of Pulse mode into Quadrature mode.....15

Changing of pulse mode into CAN mode.....16

Changing of Node Id in CAN mode.....16

Changing of Message Transmission Rate in CAN mode.....16

Change of MA-Filter in CAN mode.....16

Configuration box

Configuration box.....18

Product Overview

Warning

Please note that the EMD speed sensor may fail. Output signals may not represent correct rotation speed or direction.

Any application of the EMD speed sensor should be subjected to appropriate hazard and risk assessment, according to relevant safety standards for the application.

Reliability data MTBF for the EMD speed sensor are available on request from your Danfoss representative.

Description

Function of the speed sensor is to detect shaft speed and the direction of rotation. The sensor is mounted to the endcover of a Danfoss LSHT Orbital Motor and senses the speed from a magnet that is rotating inside the motor.

The magnet is connected to the cardan shaft (spool valve motor) or valve drive (disc valve motor) by a shaft.

Rotation of the magnet generate a rotating magnetic field that is a function of motor speed and direction.

EMD-Speed sensor convert this magnetic field into output signal of speed and direction.

Sensor princip

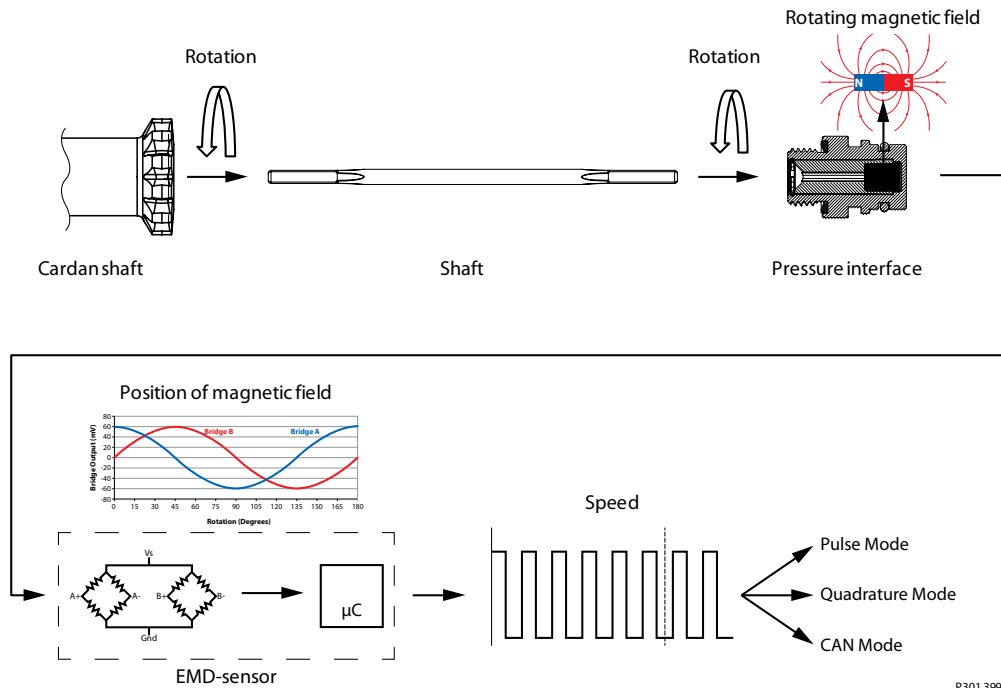

P301 399

After each Power-Up the shaft must rotate 1-2 revolutions before an output signal is generated.

General data
EMD Speed Sensor specifications
Specifications:

Output signal *			D1	D2
	Pulse mode	Push-pull output. Direction = CCW: high, CW: low Configurable up to 180 pulse/revolutions	Square Wave	Direction
	Quadrature mode	2 channels with 90° phaseshift each with 90 pulses/revolution Push-pull output	Square Wave Phase A	Square Wave Phase B
	CAN mode	Supports CAN 2.0B with SAE J1939 Message Protocol with Proprietary Messages Baudrate: 250 kbaud (fixed) Shaft velocity: ± 2500 rpm		
Speed range		0 - 2500 rpm		
Supply voltage		9 - 36 Vdc		
Maximum power		0.8 W		
Temperature range (ambient)		-30 °C to 60 °C		
EMC-Immunity (EMI):		100 V/m ISO 13766		
Grade of enclosure †		IP 69 K		
Vibration		30 G (294 m/s ²)		
Shock		50 G (490 m/s ²)		

* Configurable with PLUS+1® Service Tool - Please contact Danfoss for further information.

† According to IEC 529.

Signal definition

Pulse mode

The sensor generates a speed dependent pulse on D1 and a direction signal on D2.

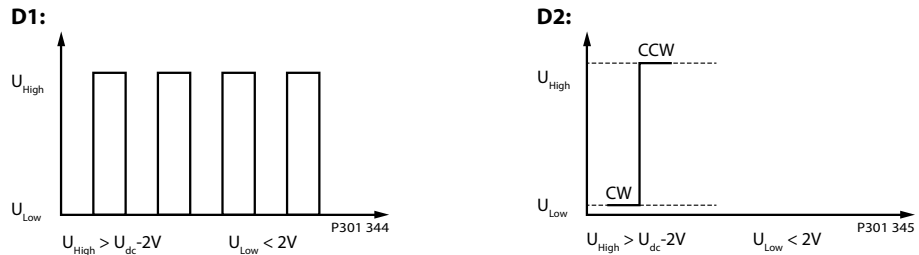

Quadrature mode

The sensor generates a speed dependent pulse on D1 and D2 with a 90 degree phaseshift.

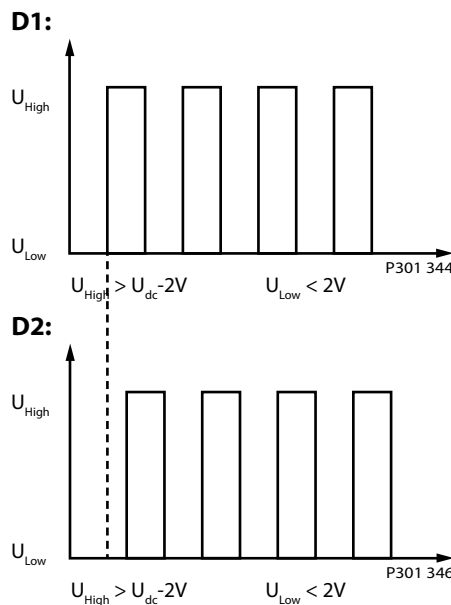

It's not recommended to use quadrature mode for OMM orbital motors. Please contact Danfoss for further information.

CAN mode

Cyclic message specification

Interface: CAN 2.0 B
 Baud rate: 250 kBaud
 Transmit rate: 10, 20, 50 (default), 100 or 200 ms (cyclic message transmission)

Proprietary B 29 bit	Data							
	0 (LSB)	1 (MSB)	2	3 (LSB)	4 (MSB)	5	6 (LSB)	7 (MSB)
CAN ID	Reserved		Sequence number	Angular velocity		Reserved	CRC-16	

Signal definition

CAN ID:	J1939 proprietary B. Programmable 29 bit message id. ID = \$18FF20XX (source address XX is programmable, default value is \$51)
Sequence no.:	byte (0-255) Increments 1 for each message
Angular velocity:	Angular velocity of the shaft. 16 bit integer with 2's complementary encoding for negative values (-25,000 to 25,000). -25,000 = -2,500 RPM (CCW) 0 = 0 RPM 25,000 = 2,500 RPM (CW)
CRC-16:	The standard CRC16 polynomial is used to calculate the checksum for byte 0 – 5. ($x^{16}+x^{15}+x^2+1$)

Filter parameter

In order to reduce noise when the frequency is calculated in pulse mode or the angular velocity is calculated in CAN mode, a moving average filter can be activated by setting a filter parameter (MA-filter) when configuring the sensor.

Valid range for the **M**oving **A**verage **P**ulse period time **N**umber (MAPN): 1, 2, 4, 8, 16, 32 & 64.

The (MAPN) can also be dynamic. Valid range is the same 1,2,4...64, the calculation is dependent on the detected speed and 2 types of filter-calculation, Dynamic 1 (default) & Dynamic 2 can be used.

How Dynamic 1 and Dynamic 2 select the MAPN see the table below.

RPM	MAPN	
	Dynamic 1	Dynamic 2
2.0 – 3.4	1	1
3.5 - 5.1	1	2
5.2 - 10	2	4
10 - 20	4	8
20 - 80	8	16
81 - 163	16	32
164 - 2500	32	64

Configuration of filter, see [Configuration of EMD-Speed Sensor to other settings](#) on page 13.

Positioning

When use the EMD-sensor in positioning applications.

It's possible to use the EMD sensor as feed-back / "encoder" in positioning applications.

In such applications use pulse mode 180 PPR or Quadrature mode, as you in all other settings will get an adding error.

The typical backlash in the Orbit motors are shown in the table below:

Motor	Backlash Output shaft -> Sensor shaft				
	OMP	OMR	OMS	OMT	OMV
Minimum	1.2°	1.2°	9.1°	7.9°	8.0°
Maximum	2.2°	2.2°	14.0°	12.4°	12.1°

Danfoss don't recommend to use OMM orbit motors in positioning applications where EMD sensor is used.

Product overview

Dimensions

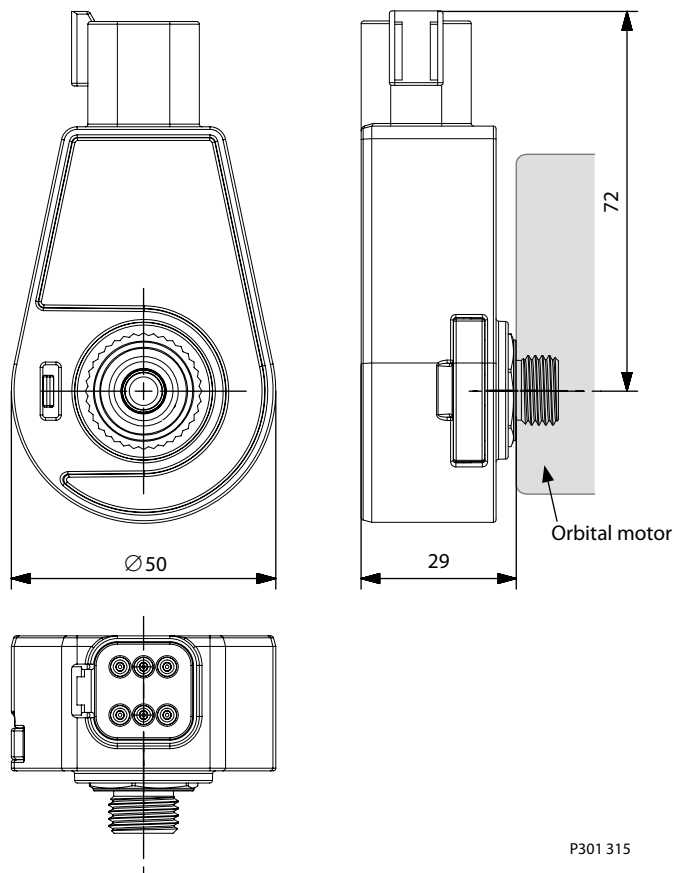

P301 315

Sensor pinout

Sensor pinout

Pin	Controller function
1	Power supply 9-36 V dc
2	Power ground -
3	D 1 (configurable output)
4	CAN L
5	CAN H
6	D 2 (configurable output)

Product overview

Deutsch DT connector – 6 pin

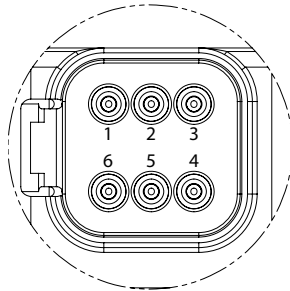

P301 314

Mating connector

Deutsch DT connector 6 pin Mating connector assembly: (Not offered by Danfoss).

Pcs	Description	Deutsch® part no.	Color
1	Plug	DT06-6S-PO12	(black)
1	Wedgelock	W6S-PO12	(green)
6	Solid Contacts	0462-209-16141	(nickel)
Options			
1	Boot	DT6S-BT-BK	(black)

For correct mounting please see Deutsch® homepage: www.deutsch.net

Wiring diagram

Wiring diagram: Pulse and quadrature mode

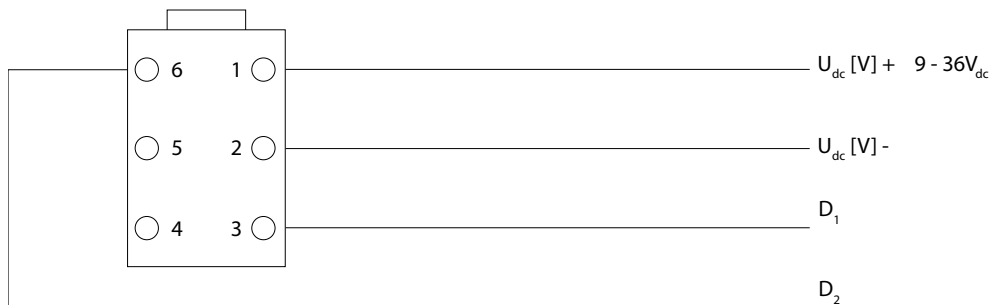

P301 400

Wiring diagram: CAN mode

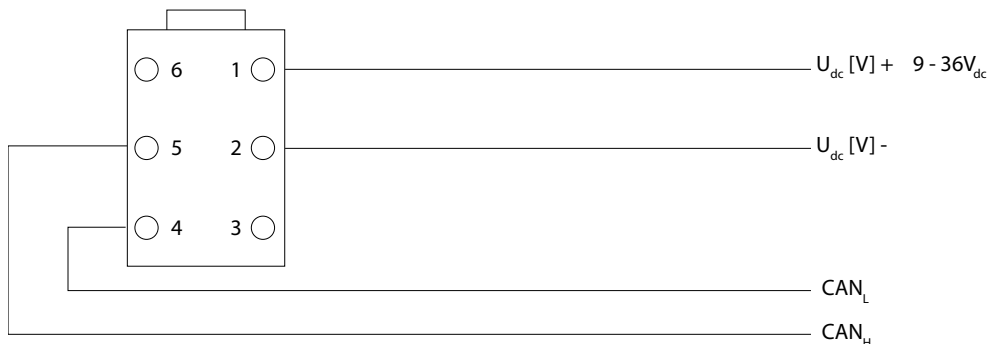

P301 401

Product overview

Conversion diagram

It is possible to replace an Orbital Motor with EM-sensor with PNP or NPN open collector output with an Orbital Motor with EMD-sensor. Conversion diagrams show how it is possible to replace present sensor with EMD-sensor.

The resistor R_L which is used in the current NPN/PNP diagram is not needed but can under certain conditions remain in the circuit:

- If $R_L < U_{DC}/10 \text{ mA}$ remove or increase the size of the resistor.
- If $R_L > U_{DC}/10 \text{ mA}$ no change needed.

In case the EM-sensor and the controller have different power supply, it is needed to modify the circuit so that the EMD-sensor has the same power supply as the controller.

PNP Open Collector Output

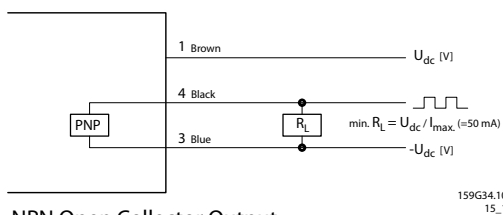

NPN Open Collector Output

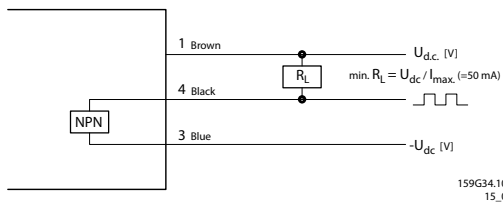

EMD-Speed Sensor

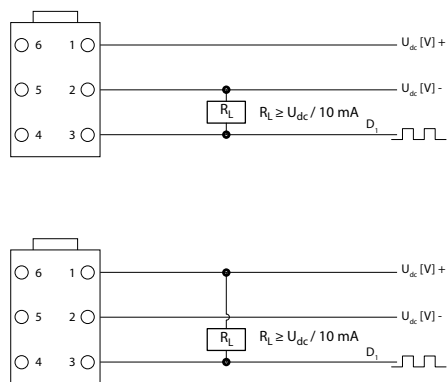

P301 402

Mounting of EMD Speed Sensor

Mounting of EMD Speed Sensor on LSHT Motors

Turn the sensor to the desired position and mount the sensor on the plug.

It is possible to mount the sensor in 36 positions.



To lock the sensor, push the clip into the sensor as shown.



Configuration of EMD-Speed Sensor to other settings

Connect configuration box

Use CG150-2 CAN/USB gateway interface communicator and configuration box. See [Configuration box](#) on page 18.

1. Switch on power supply.
2. Upstart PLUS+1® Service Tool (P1D software).

P1D file for EMD can be found here:

<http://powersolutions.danfoss.com/products/PLUS-1-GUIDE/GUIDE-service-tool-software-and-license>

Start Screen

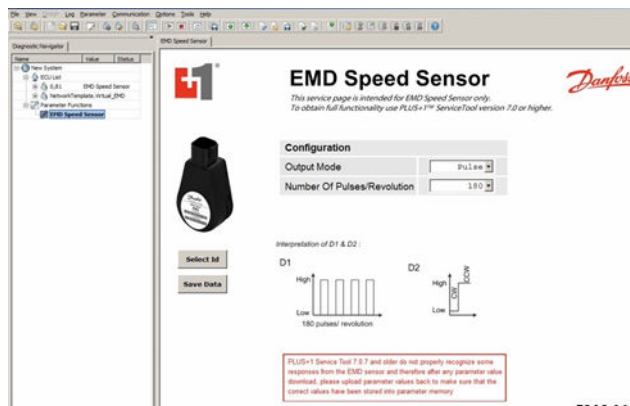

F302 066

Changing of numbers of pulses/rev in pulse mode

Configuration of EMD-Speed Sensor to other settings

1. Upload the EMD-speed sensor setting to computer 
 OEM configurable sensor 11114575 has following default setting:

Configuration	
Output Mode	Pulse
Number Of Pulses/Revolution	180

F302 067

2. Change of numbers of Pulses/Rev in Pulse mode for example to 60 pulses / rev: Select 60
 Valid range for pulses: 20 – 120 pulses / rev + 180 pulses / rev.

Configuration	
Output Mode	Pulse
Number Of Pulses/Revolution	60
MA-Filter	Dynamic 1

F302 068

MA-Filter is default Dynamic 1 (See below for change of MA-Filter).

3. Download selected parameter to EMD speed sensor 

PLUS+1 Service Tool 7.0.7 and older do not properly recognize some responses from the EMD sensor and therefore after any parameter value download, please upload parameter values back to make sure that the correct values have been stored into parameter memory

F302 069

Change of MA-Filter in Pulse mode

MA-Filter is default Dynamic 1 in the range 20 - 120 pulses / rev.

Configuration of EMD-Speed Sensor to other settings

MA-Filter is not available at 180 pulses / rev.

1. Change MA-Filter in Pulse mode for example to 16: Select 16

Configuration	
Output Mode	Pulse
Number Of Pulses/Revolution	60
MA-Filter	16

F302 070

2. Download selected parameter to EMD speed sensor

Changing of Pulse mode into Quadrature mode

1. Upload the EMD-speed sensor setting to computer

OEM configurable sensor 11114575 has following default setting:

Configuration	
Output Mode	Pulse
Number Of Pulses/Revolution	180

F302 067

2. Change of mode from Pulse mode to Quadrature mode. Select Quadrature

Configuration	
Output Mode	Quadrature

F302 071

3. Download selected parameter to EMD speed sensor

Configuration of EMD-Speed Sensor to other settings

Changing of pulse mode into CAN mode

1. Upload the EMD-speed sensor setting to computer

OEM configurable sensor 11114575 has following default setting:

Output Mode	Pulse
Number of Pulses/Revision	180

F302 072

2. Change of mode from Pulse mode to CAN mode. Select CAN

Configuration	
Output Mode	CAN
Node Id	0x51
Message Transmission Rate	50 ms
MA-Filter	Dynamic 1

Interpretation of D1 & D2 :

No output on pins. Information about speed and direction can be read on CAN bus.

Live Data	
Speed [RPM]	0

F302 073

3. Download selected parameter to EMD speed sensor

Changing of Node Id in CAN mode

OEM configurable sensor 11114575 has following default Node Id: 0x51

1. Change Node Id from 0x51 to for example to 0x54. Select 0x54

Node Id	0x54
---------	------

F302 075

2. Download selected parameter to EMD speed sensor:

Changing of Message Transmission Rate in CAN mode

OEM configurable sensor 11114575 has following default Message Transmission Rate: 50 ms.

EMD speed sensor has following Message Transmission Rate setting range: 10, 20, 50, 100, 200 ms

1. Change Message Transmission Rate from 50 ms to for example 100 ms. Select 100 ms

Message Transmission Rate	100 ms
---------------------------	--------

F302 076

2. Download selected parameter to EMD speed sensor:

Change of MA-Filter in CAN mode

OEM configurable sensor 11114575 has following default MA-Filter: Dynamic 1

MA-Filter	Dynamic 1
-----------	-----------

F302 077

Configuration of EMD-Speed Sensor to other settings

EMD speed sensor has following MA-Filter setting range: 1, 2, 4, 8, 16, 32, 64, Dynamic 1, Dynamic 2

1. Change MA-Filter from Dynamic 1 to for example 16. Select 16

Configuration	
Output Mode	<input type="text" value="CAN"/>
Node Id	<input type="text" value="0x51"/>
Message Transmission Rate	<input type="text" value="50 ms"/>
MA-Filter	<input type="text" value="16"/>

F302 078

2. Download selected parameter to EMD speed sensor: 

Configuration box

Configuration box

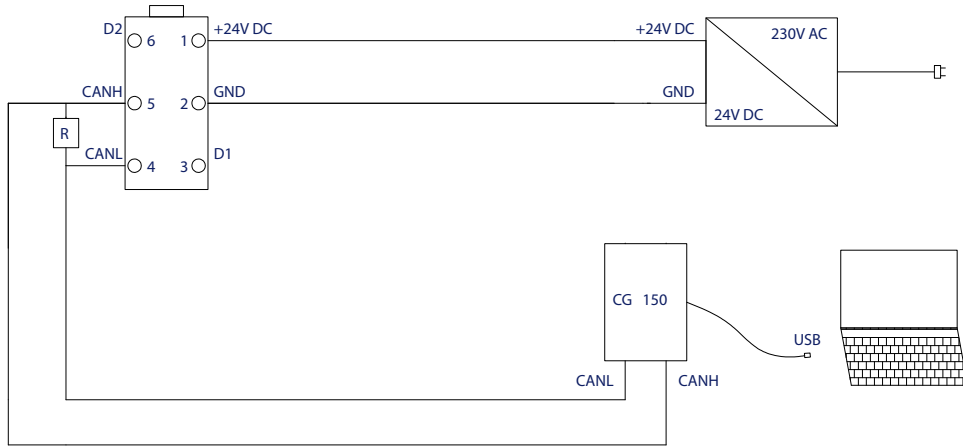

R = 120Ω

P301 410

Order information: CG150-2 CAN/USB gateway interface communicator: Danfoss part number 11153051.

[PLUS+1® Service Tool V7.1.10 is needed to support CG150-2](#)



Products we offer:

- Bent Axis Motors
- Closed Circuit Axial Piston Pumps and Motors
- Displays
- Electrohydraulic Power Steering
- Electrohydraulics
- Hydraulic Power Steering
- Integrated Systems
- Joysticks and Control Handles
- Microcontrollers and Software
- Open Circuit Axial Piston Pumps
- Orbital Motors
- PLUS+1® GUIDE
- Proportional Valves
- Sensors
- Steering
- Transit Mixer Drives

Danfoss Power Solutions is a global manufacturer and supplier of high-quality hydraulic and electronic components. We specialize in providing state-of-the-art technology and solutions that excel in the harsh operating conditions of the mobile off-highway market. Building on our extensive applications expertise, we work closely with our customers to ensure exceptional performance for a broad range of off-highway vehicles.

We help OEMs around the world speed up system development, reduce costs and bring vehicles to market faster.

Danfoss – Your Strongest Partner in Mobile Hydraulics.

Go to www.powersolutions.danfoss.com for further product information.

Wherever off-highway vehicles are at work, so is Danfoss. We offer expert worldwide support for our customers, ensuring the best possible solutions for outstanding performance. And with an extensive network of Global Service Partners, we also provide comprehensive global service for all of our components.

Please contact the Danfoss Power Solution representative nearest you.

Comatrol

www.comatrol.com

Schwarzmueller-Inverter

www.schwarzmueller-inverter.com

Turolla

www.turollaocg.com

Valmova

www.valmova.com

Hydro-Gear

www.hydro-gear.com

Daikin-Sauer-Danfoss

www.daikin-sauer-danfoss.com

Local address:

Danfoss Power Solutions (US) Company
2800 East 13th Street
Ames, IA 50010, USA
Phone: +1 515 239 6000

Danfoss Power Solutions GmbH & Co. OHG
Krokamp 35
D-24539 Neumünster, Germany
Phone: +49 4321 871 0

Danfoss Power Solutions ApS
Nordborgvej 81
DK-6430 Nordborg, Denmark
Phone: +45 7488 2222

Danfoss Power Solutions (Shanghai) Co., Ltd.
Building #22, No. 1000 Jin Hai Rd
Jin Qiao, Pudong New District
Shanghai, China 201206
Phone: +86 21 3418 5200

Danfoss can accept no responsibility for possible errors in catalogues, brochures and other printed material. Danfoss reserves the right to alter its products without notice. This also applies to products already on order provided that such alterations can be made without changes being necessary in specifications already agreed. All trademarks in this material are property of the respective companies. Danfoss and the Danfoss logotype are trademarks of Danfoss A/S. All rights reserved.