

# Galaxy

## DX 2547

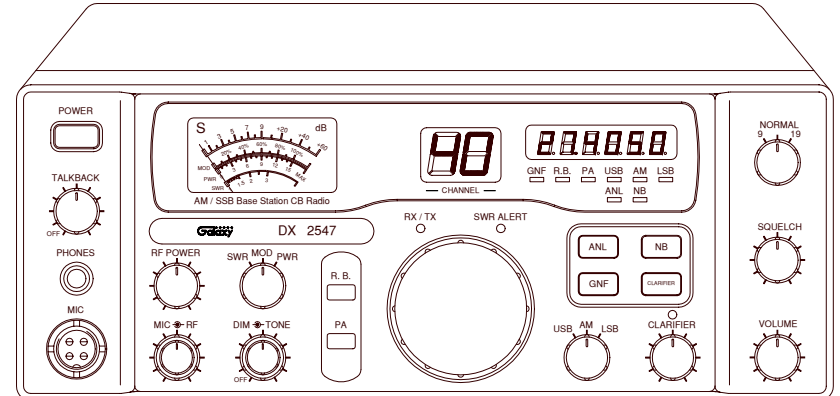

**AM/ SSB Two Way  
Citizen Band Base Station Transceiver**

Printed In Malaysia  
AT2547010A  
PD0009028

## OWNER'S MANUAL

## TABLE OF CONTENTS

	PAGE
<b>CHAPTER 1</b>	
<b>Specifications</b> .....	2
<b>CHAPTER 2</b>	
<b>Installation</b> .....	3
Location .....	3
Ignition Noise Interference .....	3
Antenna .....	3
External Speaker .....	5
Phone Jack .....	5
Public Address .....	5
<b>CHAPTER 3</b>	
<b>Operation</b> .....	6
Control Function .....	6
Front Panel .....	6
Rear Panel .....	10
Frequency Chart .....	11
Procedure to Receive And Transmit .....	12
Receiving SSB Signals .....	13
Alternate Microphone And Installation .....	15
Maintenance and Adjustment .....	18
A Few Rules That Should Be Obeyed .....	19
How Your CB can Serve You .....	19
Use Channel 9 for Emergency Message Only .....	20
Warranty .....	21

## CHAPTER 1 SPECIFICATIONS

### GENERAL

Channels	40
Frequency Range	26.965 ~ 27.405 MHz
Emission	AM/USB/LSB
Frequency Control	Phase-Lock-loop (PLL) Synthesizer
Frequency Tolerance	0.005%
Frequency Stability	0.003%
Temperature Range	-30°C to +50°C
Antenna Impedance	50 Ohms
Antenna Connectors	Standard SO-239 type
Meter Function	Meter#1 RF output Power / Antenna SWR Meter#2 Received signal strength / MOD %
Input Voltage	AC 120V, 60Hz

### TRANSMITTER

RF Power Output	AM 4W ; USB/LSB 12W PEP
Antenna Connector	UHF Type, 50 Ohms
AM Modulation	Up to 100%
Spurious Emission	Better than -60 dB
Unwanted Sideband	Better than -60 dB

### RECEIVER

Sensitivity for 10 dB (S+N)/N	AM : 0.5 uV, USB/LSB : 0.15 uV
Adjacent Channel Rejection	-60dB
Image Rejection	-50dB
AGC Figure of Merit	50 mV for 10dB Change in Audio Output
Audio Power Output	2.5W @ 10% Distortion
Audio Response	300 to 2500 Hz

## CHAPTER 2 INSTALLATION

### LOCATION

Choose a location close to an AC power outlet and convenient for running the antenna lead-in cable. This transceiver is attached with the AC power cord set. Proceed as follows to complete all necessary connections to the transceiver.

1. Your transceiver has a standard antenna connector type, SO-239 located on the rear panel for easy connection to the standard PL-259 coax plugs. If the coax antenna cable must be made longer, use only enough coax cable to suit your needs with impedance of 50 ohms, frequency range from 26.965 to 27.405 MHz. This will insure proper impedance match and maximum power transfer from the transmitter to the antenna.
2. Use 120V AC power for the base station.

### NOISE INTERFERENCE

There are several kinds of noise interference you may encounter in base station operation. Some of these noises come from fluorescent light, electrical appliance, lawnmower, nearby commercial broadcast etc. Commercial products are available to reduce interference from these sources. Consult your dealer or professional amateur radio supplier.

Even though the transceiver has ANL and NB controls, in some installation ignition interference may be high enough to make good communications impossible. The electrical noise may come from several sources. Many possibilities exist as variations between vehicles require different solutions to reduce the noise.

### ANTENNA

For best transmission and reception, your transceiver should use an antenna especially designed for a frequency of 27 MHz. Antenna is to be purchased separately and it comes with the installation instructions. Numerous types of antennas are available. Some emphasize on ease of installation while others emphasize on performance. Often the difference in performance for these antennas is modest.

1. **Vertical Ground Plane Antenna :** Omni directional antennas provide optimum performance for contacting other fixed stations using vertical type antennas in addition to all mobile stations. For medium long range communications work.

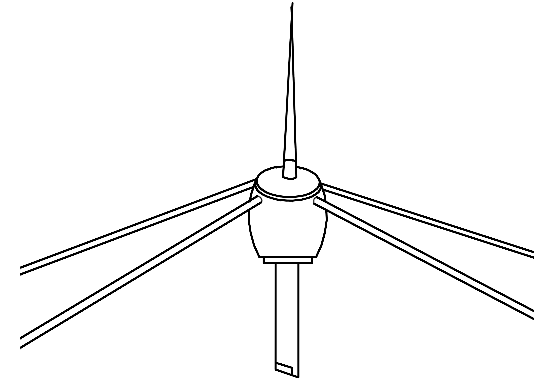

Ground Plane

2. **Directional Beam Antenna :** Highly efficient and directional antenna generally intended for fixed-to-fixed long range communications.

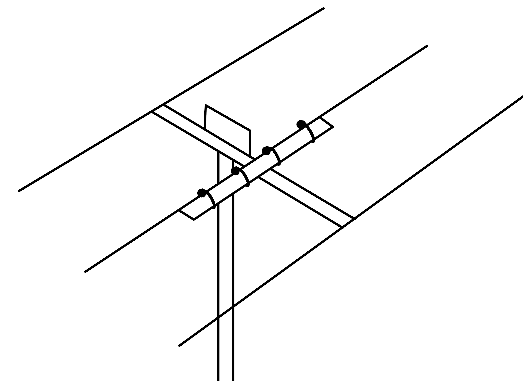

Directional Beam Antenna

# CHAPTER 3 OPERATION

## CONTROL FUNCTIONS FRONT PANEL

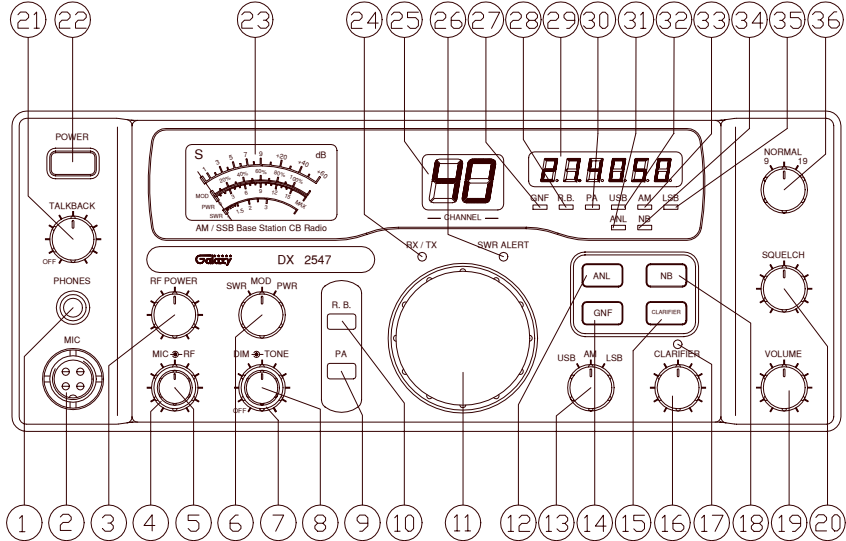

- 1. PHONE JACK :** Used to connect headphones for listening.
- 2. MICROPHONE JACK :** Used to connect microphone for voice source.
- 3. RF POWER CONTROL :** This control allows the user to adjust RF power output.
- 4. RF GAIN CONTROL :** This control is used to reduce the gain of the RF amplifier under strong signal conditions.
- 5. MIC GAIN CONTROL :** Adjust the microphone gain in the transmit and PA modes. This controls the gain to the extent that full talk power is available several inches away from the microphone. In the Public Address (PA) mode, the control function as the volume control.

### EXTERNAL SPEAKER

The external speaker jack (EXT. SP.) on the rear panel is used for remote receiver monitoring. The external speaker should have 8 ohms impedance and be able to handle at least 4 watts. When the external speaker is plugged in, the internal speaker is disconnected.

### PHONE JACK

This PHONE jack accepts headphone of 4 to 32 ohms impedance. When a headphone is plugged into this jack, both internal and external speakers are silenced simultaneously.

### PUBLIC ADDRESS

To use the transceiver as a public address system, connect an external 8 ohms speaker (4 watts minimum) to the PA. SP. jack located on the rear panel. Direct speaker away from the microphone to prevent acoustic feedback. Physical separation or isolation of the microphone and speaker is important when operating the PA at high output levels.

6. **SWR/MOD/PWR SWITCH** : This switch controls the function of the meter during the transmit mode. In the “SWR” position, the meter indicates the Standing Wave Ratio (SWR) of your antenna. There are no adjustments because the SWR circuit in this radio calibrates itself automatically. When the switch is in the “MOD” position, the green scale on the meter indicates your percentage of modulation. It is most accurate when testing at 4 watts output. This operates in AM only, not in SSB. When this switch is in “PWR” position, the meter indicates your power output.
7. **DIMMER CONTROL** : This knob controls the level of brightness for the meter lamp and channel display.
8. **TONE CONTROL** : This control changes tone quality in receive only. In clockwise rotation, treble is increased and in counter clockwise rotation, bass is increased.
9. **PA/OFF SWITCH** : In the “PA” position, your voice will come out of the speaker that you need to plug in to the “PA.SP” jack on the back of the radio. The radio does not operate when you are in the “PA” mode.
10. **ROGER BEEP SWITCH** : In the Roger Beep position, the radio transmits an audio tone at the end of your transmission to indicate that transmission has ended. As a courtesy to others, use the Roger Beep only when necessary.
11. **CHANNEL SELECTOR** : This control is used to select a desired transmit and receive channel.
12. **ANL/OFF SWITCH** : In the “ANL” position, the Automatic Noise Limiter is activated.
13. **MODE SWITCH** : This control allows you to select one of the following operating modes: USB/AM/LSB.
14. **GNF/OFF SWITCH** : In the “GNF” mode, you are in CB operation but the Galaxy Noise Filter is engaged. This is a special noise filter that de-emphasizes audio high frequency response in order to increase the signal-to-noise ratio of weak signals. While you will notice a dramatic reduction in the “rushing” sound when this filter is activated, it does not have much effect on the signal-to-noise of strong signals.
15. **CLARIFIER/OFF SWITCH** : Pushing this switch turns the Clarifier on and off.
16. **CLARIFIER CONTROL** : Allows tuning of the receive frequency above or below the channel frequency by up to 1.0KHz. Although this control is intended primarily to tune in SSB signals, it may be used to optimize AM signals.
17. **CLARIFIER LED** : This LED lights when the clarifier is on.
18. **NB/OFF SWITCH** : In the “NB” position, the Noise Blanker is activated. The Noise Blanker is very effective in eliminating repetitive impulse noise such as ignition interference.
19. **VOLUME CONTROL** : Turn clockwise to set the desired listening level.
20. **SQUELCH CONTROL** : This switch is used to eliminate background noise being heard through the receiver which can be disturbing when no transmission are being heard through the received. To use this feature, turn the switch fully counterclockwise and then turn clockwise slowly until the background noise is just eliminated. Further clockwise rotation will increase the threshold level which a signal must overcome in order to be heard. Only strong signal will be heard at a maximum clockwise setting.
21. **TALKBACK CONTROL** : Turn clockwise to activate Talkback circuit. Adjust this knob for desired volume of Talkback. This is used to monitor your own voice. For example, you could use this feature to compare different microphones.
22. **POWER ON/OFF CONTROL** : Pushing this switch to apply power to the unit.
23. **FRONT PANEL METER** : The Front Panel Meter allows the user to monitor signal strength, RF output power, SWR level and AM Modulation level.
24. **TX/RX LED** : The red LED indicates the unit is in the transmit mode. The green LED indicates the unit is in the receive mode.
25. **CHANNEL DISPLAY** : The channel display indicates the current selected channel.
26. **SWR ALERT LED** : This LED lights red when your SWR is higher than about 3:1. This is not an exact indicator of 3:1 SWR, but it is an indication that you should check your SWR reading.

- 27. **GNF LED** : This LED lights red when the GNF is on.
- 28. **R.B. LED** : This LED lights green when the Roger Beep is on.
- 29. **FREQUENCY COUNTER** : This display indicates the frequency of the selected channel.
- 30. **PA LED** : This LED lights red when the radio is in the PA mode.
- 31. **ANL LED** : This LED lights red when the ANL is on.
- 32. **USB LED** : This LED lights red when the radio is in the USB mode.
- 33. **AM LED** : This LED lights red when the radio is in the AM mode.
- 34. **NB LED** : This LED lights red when the NB is on.
- 35. **LSB LED** : This LED lights red when the radio is in the LSB mode.
- 36. **CH9/CH19 SWITCH** : This control allows you to select CH 9 or CH19 instantly. When the switch is placed in the “NORMAL” position, the user is allow to select a desired transmit and receive channel.

## REAR PANEL

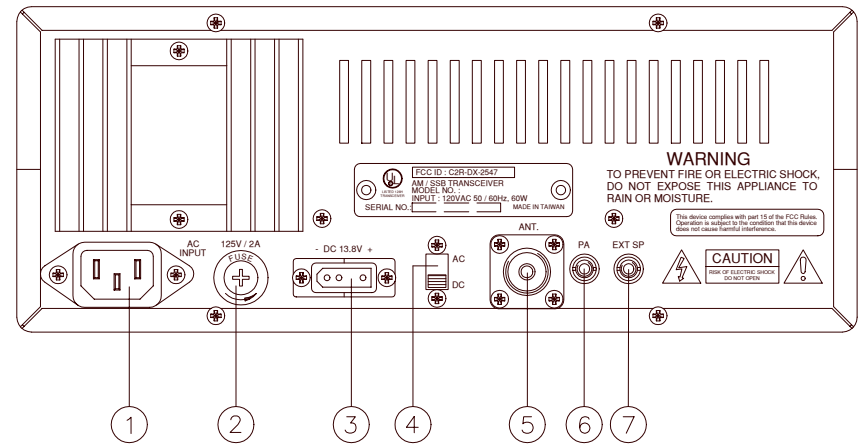

1. **AC POWER CORD** : Connect to AC power outlet for ac main supply.
2. **FUSE** : Accommodates a fuse for AC input circuit protection. Use 125V 2A fuse for replacement.
3. **DC POWER** : This accepts 13.8V DC power cable with built-in 7A fuse. The power cord provided with the radio has a black and red wire. The black goes to negative and red goes to positive.
4. **AC/DC POWER SELECTOR** : This control is used to select a desired power supply of AC power or DC power.
5. **ANTENNA** : This jack accepts 50 ohms coaxial cable with a PL-259 type plug.
6. **PA SP.** : This jack is for PA operation. Before operating, you must first connect a PA speaker (8 ohms, 4W) to this jack.
7. **EXT. SP** : This jack accepts 4 to 8 ohms, 5 watts external speaker. When the external speaker is connected to this jack, the built-in speaker will be disabled.

## FREQUENCY CHART

Channel	Channel Frequency	Channel	Channel Frequency
1	26.965 MHz	21	27.215 MHz
2	26.975 MHz	22	27.225 MHz
3	26.985 MHz	23	27.255 MHz
4	27.005 MHz	24	27.235 MHz
5	27.015 MHz	25	27.245 MHz
6	27.025 MHz	26	27.265 MHz
7	27.035 MHz	27	27.275 MHz
8	27.055 MHz	28	27.285 MHz
9	27.065 MHz	29	27.295 MHz
10	27.075 MHz	30	27.305 MHz
11	27.085 MHz	31	27.315 MHz
12	27.105 MHz	32	27.325 MHz
13	27.115 MHz	33	27.335 MHz
14	27.125 MHz	34	27.345 MHz
15	27.135 MHz	35	27.355 MHz
16	27.155 MHz	36	27.365 MHz
17	27.165 MHz	37	27.375 MHz
18	27.175 MHz	38	27.385 MHz
19	27.185 MHz	39	27.395 MHz
20	27.205 MHz	40	27.405 MHz

## PROCEDURE TO RECEIVE AND TRANSMIT

### A. MICROPHONE

The receiver and transmitter are controlled by the push-to-talk switch on the microphone. Press the switch and the transmitter is activated, release switch to receive. When transmitting, hold the microphone two inches from the mouth and speak clearly in a normal voice. This transceiver comes complete with a low impedance dynamic microphone.

### B. PROCEDURE TO RECEIVE

1. Be sure that power source, microphone and antenna are connected to the proper connectors before going to the next step.
2. Press the **POWER** switch to apply power to the radio.
3. Set the **VOL** for a comfortable listening level.
4. Set the **MODE** switch to the desired mode.
5. Listen to the background noise from the speaker. Turn the **SQ** knob slowly clockwise until the noise just disappears. The **SQ** is now properly adjusted. The receiver will remain quiet until a signal is actually received. Do not advance the control too far or some of weaker signals will not be heard.
6. Set the **CHANNEL** selector switch to the desired channel.
7. Set the **RF GAIN** control fully clockwise for maximum RF gain.

### C. RF POWER CONTROL

This feature allows for the adjustment of the RF power output continuously over the range of 1 to 4 watts in AM and 4 to 12 watts in USB or LSB.

### D. PROCEDURE TO TRANSMIT

1. Select the desired channel of transmission
2. Set the **MIC GAIN** control fully clockwise.
3. If the channel is clear, depress the push-to-talk switch on the microphone and speak in a normal voice.

## RECEIVING SSB SIGNALS

There are three types of signals presently used for communications in the Citizens Band : AM, USB, LSB. When the MODE switch on your unit is placed in the AM position, only standard double-side band, full carrier signals will be detected. An SSB signal may be recognized while in the AM mode by its characteristic "Donald Duck" sound and the inability of the detector to produce an intelligible output. The USB and LSB modes will detect upper side band and lower side band respectively, and standard AM signals.

SSB reception differs from standard AM reception in that an SSB receiver does not require a carrier or opposite side band to produce an intelligible signal. A single-side band transmitted signal consists only of the upper or the lower side band and no carrier is transmitted. The elimination of the carrier from the AM signal helps to eliminate the biggest cause of whistles and tones heard on channels which make even moderately strong AM signals unreadable. Also, SSB takes only half the space of an AM channel, therefore two SSB conversations will fit into each channel, expanding the 40 AM channels to 80 SSB channels. The reduction in channel space required also helps in the receiver because only half of the noise and interference can be received with 100% of the SSB signal.

An SSB signal may be received only when the listening receiver is functioning in the same mode. In other words, an upper side band signal (USB) may be made intelligible only if the receiver is functioning in the USB position.

If a lower side band (LSB) signal is heard when the receiver is in the USB mode, no amount of tuning will make the signal intelligible. The reason for this may be understood if you consider that when the modulation is applied to the transmitter's microphone in the USB mode, the transmitter output frequency is increased whereas in the LSB mode the transmitter's output frequency is decreased.

The result in listening to the receiver is that when the MODE switch is in the proper position (either USB or LSB), a true reproduction of a single tone of modulation will result, and if the tone is increased in frequency (such as a low-pitched whistle or a high-pitched whistle) you will hear the increase in the output tone of the receiver. If the incorrect mode is selected, an increase in tone of a whistle applied to the transmitter will cause a decrease in the resultant tone from the receiver.

Thus when a voice is used in place of a whistle or tone, in the proper listening mode the voice will be received correctly whereas in the incorrect mode, the voice will be translated backwards and cannot be made intelligible by the CLARIFIER control. When listening to an AM transmission, a correct side band is heard in either mode since both upper and lower side bands are received.

Once the desired SSB mode has been selected, frequency adjustment may be necessary in order to make the incoming signal intelligible. The CLARIFIER control allows the operator to vary frequency above or below the exact frequency of the channel. If the sound of the incoming signal is high or low pitched, adjust the operation of the CLARIFIER.

Consider it as performing the same function as a phonograph speed control. When the speed is set too high, voices will be high-pitched and if set too low, voice will be low-pitched. Also, there is only one correct speed that will make a particular record produce the same sound that was recorded. If the record is played on a turntable that is rotated in the wrong direction (opposite side band) no amount of speed control (CLARIFIER) will produce an intelligible sound.

An AM signal received while listening in one of the SSB modes will produce a steady tone (carrier) in addition to the intelligence, unless the SSB receiver is tuned to exactly the same frequency by the CLARIFIER control. For simplicity, it is recommended that the AM modes be used to listen to AM signals.



## ALTERNATE MICROPHONES AND INSTALLATION

For best results, the user should select a low-impedance dynamic type microphone or a transistorized microphone. Transistorized type microphones have low output impedance characteristics. The microphones must be provided with a four-lead cable. The audio conductor and its shielded lead comprise two of the leads. The third lead is for transmit control and the fourth is for receiving control.

The microphone should provide the functions shown in schematic below.

### 4 WIRE MIC CABLE

Pin Number	Mic Cable Lead
1	Audio Shield
2	Audio Lead
3	Transmit Control
4	Receive Control

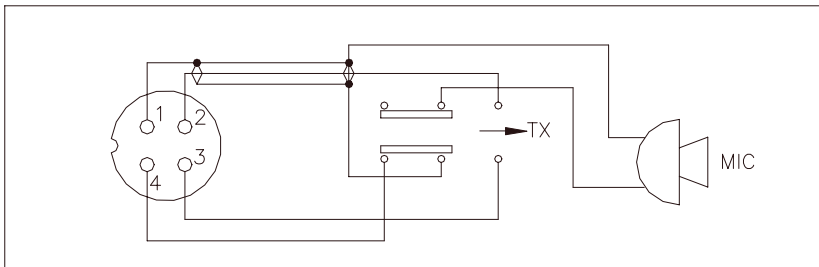
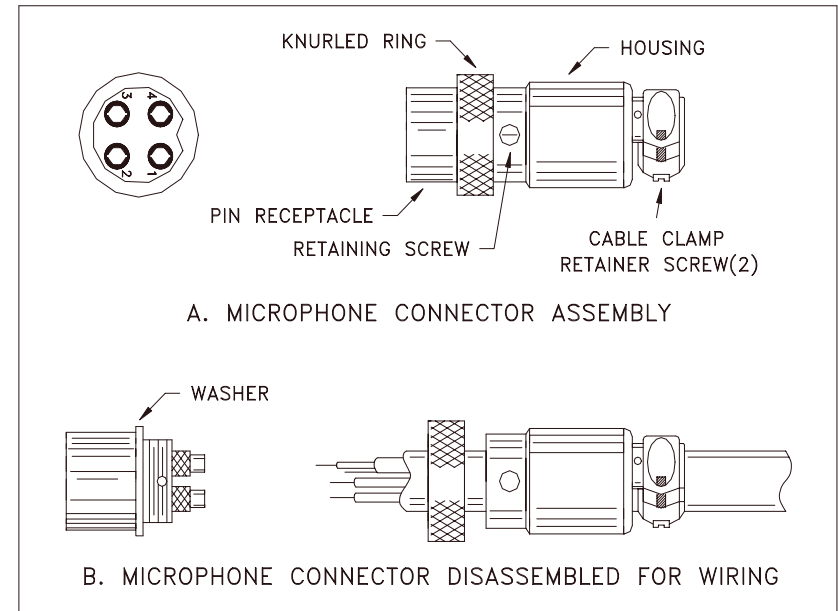

**Fig. 1** Your transceiver microphone schematic.

If the microphone to be used is provided with precut leads, they must be revised as follows.

1. Cut leads so that they extend 7/16" beyond the plastic insulating jacket of the microphone cable.
2. All leads should be cut to the same length. Strip the ends of each wire 1/8" and tin the exposed wire.

Before beginning the actual wiring, read carefully the circuit and wiring information provided with the microphone you select. Use the minimum heat required in soldering the connections. Keep the exposed wire lengths to a minimum to avoid shorting when the microphone plug is reassembled.

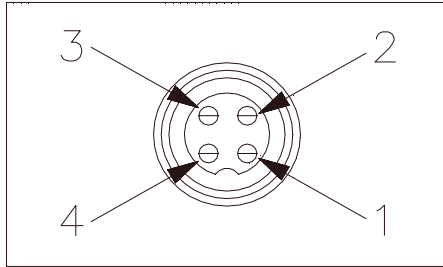

**Fig. 2** Microphone plug wiring

To wire the microphone cable to the plug provided, proceed as follows :

1. Remove the retaining screw.
2. Unscrew the housing from the pin receptacle body.
3. Loosen the two cable clamp retainer screws.
4. Feed the microphone cable through the housing, knurled ring and washer as shown Figure 2.

- The wires must now be soldered to the pins as indicated in the above wiring tables. If a vise or clamping tool is available it should be used to hold the pin receptacle body during the soldering operation, so that both hands are free to perform the soldering. If a vise or clamping tool is not available, the pin receptacle body can be held in a stationary position by inserting it into the microphone jack on the front panel. The numbers of the microphone plug are shown in Fig. 3, as viewed from the back of the plug. Before soldering the wire to the pins, pre-tin the wire receptacle of each pin of the plug.



**Fig. 3** Microphone plug pin numbers viewed from rear of pin receptacle.

- Be sure that the housing and the knurled ring of Figure 2 are pushed back onto the microphone cable before starting to solder. If the washer is not captive to the pin receptacle body, make sure that it is placed on the threaded portion of the pin receptacle body before soldering.
- If the microphone jack is used to hold the pin receptacle during soldering operation, best results are obtained when the connections to pin 1 and 3 are made first and then the connections to pins 2 and 4. Use a minimum amount of soldering and be careful to prevent excessive solder accumulation on pins, which could cause a short between the pin and the microphone plug housing.
- When all soldering connections to the pins of the microphone are completed, push the knurled ring and the housing forward and screw the housing onto the threaded portion of the pin receptacle body. Note the location of the screw clearance hole in the plug housing with respect to the threaded hole in the pin receptacle body. When the housing is completely threaded into the pin receptacle body, a final fraction of a turn either clockwise or counterclockwise may be required to align the screw hole with the threaded hole in the pin receptacle body. When these are aligned, the retaining screw is then screwed into place to secure the housing to the pin receptacle body.

- The two cable clamp retainer screws should now be tightened to secure the housing to the microphone cord. If the cutting directions have been carefully followed, the cable clamp should secure to the insulation jacket of the microphone cable.
- Upon completion of the microphone plug wiring, connect and secure the microphone plug in the transceiver.

## **MAINTENANCE AND ADJUSTMENT**

This transceiver is specifically designed for the environment encountered in base installations. The use of all solid state circuitry and its light weight result in high reliability. Should a failure occur, however, replace parts only with identical parts. Do not substitute.

### **NOTE**

If the performance described in the OPERATION and MAINTENANCE AND ADJUSTMENT sections is not obtained, review the operating instructions to insure that proper procedures were followed.

### **FCC WARNING**

All transmitter adjustments other than those provided on front panel by the manufacturer must be made by or under the supervision of the holder of an FCC – issued general radio telephone operator's license.

### **A FEW RULES THAT SHOULD BE OBEYED**

1. You are not allowed to carry on a conversation with another station for more than five minutes at a time without taking a one-minute break, to give others a chance to use the channel.
2. You are not allowed to blast others off the air by over-powering them with illegally amplified transmitter power, or illegally high antennas.
3. You can't use the transceiver to promote illegal activities.
4. You are not allowed to use profanity.
5. You may not play music in your transceiver.
6. You may not use your transceiver to sell merchandised or professional service.

### **HOW YOUR CB CAN SERVE YOU**

1. Warn of traffic tie ups ahead.
2. Provide weather and road information.
3. Provide help fast in event of emergency or breakdown.
4. Suggest good spots to eat and sleep.
5. Make long trips more interesting, and help keep you awake.
6. Provide direct contact with your office or home.
7. Make friends for you as you travel.
8. Provide "local information" to find your destination.
9. Help law enforcement officers by reporting drunk and reckless drivers.

### **USE CHANNEL 9 FOR EMERGENCY MESSAGES ONLY**

The FCC gives the following examples of permitted and prohibited types of communications for use in an emergency. These are guidelines and are not intended to be all inclusive.

#### **Permitted**

<b>Permitted</b>	<b>Example Message</b>
YES	"A tornado sighted six miles north of town.
NO	"This is observation post number 10. No tornado sighted.
YES	"I am out of gas on interstate 95"
NO	"I am out of gas in my driveway"
YES	"There is a four-car collusion at exit 10 on the Beltway, send police and ambulance."
NO	"traffic is moving smoothly on the Beltway"
YES	"Base to Unit 1, the weather Bureau has just issued a thunder storm warning. Bring the sailboat into port."
NO	"Attention all motorists. The weather Bureau advises that the snow tomorrow will accumulate 4 to 6 inches.
YES	"There is a fire in the building on the corner of 6th and Main Streets."
NO	"This is Halloween patrol unit number 3. Everything is quiet here."

## **WARRANTY**

**This radio is covered by a two year limited parts and labor warranty.**

- “Limited” means that we will repair problems caused by factory defects or normal use at no charge.
- Before returning a radio to us for warranty service, please call our Service Department for a Repair Authorization Number (RAN). This RAN must be written below your return address on the outside of the shipping box. Boxes which arrive without a RAN will be refused, and the shipping company will return the unopened box to you. Be sure to have a pen and paper ready along with the serial number of your radio before calling. We will give you the RAN and our shipping address over the phone. The telephone number of the Service Department is (760) 480-8800, and we suggest calling between 10:00 AM and 4:00 PM Pacific Time.
- Please include a note with a detailed description of the symptoms. This is important because it will help the technician who works on your radio to locate your problem. Intermittent problems are easily overlooked, so be sure to give as much detail as possible in your note. Also, please include your telephone number in case our technicians have any additional questions.
- Do not send your power cord or microphone unless we ask for these items during our telephone conversation.
- You are responsible for getting the radio safely to us. (We suggest using United Parcel Service.) You must pay to ship the radio to us, and we will pay to ship the radio back to you. Since we use UPS and they do not ship to Post Offices boxes, please provide us with a street address for the return of your radio.
- We will repair and return your radio as soon as we can. We appreciate your choosing a Galaxy radio and we want you to be on the air as much as possible!

Be sure to visit our web site at

**[www.GalaxyRadios.com](http://www.GalaxyRadios.com)**