

WINAUTO



(044)361-05-06

ICQ:495-089-192

(067)469-02-12

ICQ:613-211-859

(099)048-99-03

(093)672-77-76

User's Manual

Car compressor Viair 400H (40042)

In the online store Winauto you also can buy [car compressor Viair 400H \(40042\)](#). Delivery in Kyiv and throughout Ukraine with payment upon receipt!

winauto.ua



- Archive - Audio, video - Sound and Components - Car Safety and security - Car DVRs, cameras, parking - Car Goods - Automotive Lighting - Tweak - - Sale -





- 400H – HARDMOUNT AIR COMPRESSOR KIT
PART NO. 40042

- 450H – HARDMOUNT AIR COMPRESSOR KIT
PART NO. 45042



IMPORTANT:

It is essential that you and any other operator of this product read and understand the contents of this manual before installing and using this product.

SAVE THIS MANUAL FOR FUTURE REFERENCE

USER MANUAL



IMPORTANT SAFETY INSTRUCTIONS

CAUTION - To reduce risk of electrical shock or electrocution:

- Do not disassemble. Do not attempt repairs or modifications. Refer to qualified service agencies for all service and repairs.
- Do not use this product in or area where it can fall or be pulled into water or other liquid.
- Do not reach for this product if it has fallen into liquid.
- Use this compressor with 12-volt DC systems only.
- This product should never be left unattended during use.

WARNING - To prevent injury:

- Never allow children to operate this compressor. Close supervision is necessary when this compressor is being used near children.
- This compressor will become very hot during and immediately after use. Do not touch any part of this compressor with bare hands, other than the ON/OFF switch, during and immediately after use.
- Do not use this product near flames or explosive materials or where aerosol products are being used.
- Do not operate this product where oxygen is being administered.
- Do not pump anything other than atmospheric air.
- Never use this product while sleepy or drowsy.
- Do not use any tools or attachments without first determining maximum air pressure for that tool or attachment.
- Never point any air nozzle or air sprayer toward another person or any part of the body.
- This air compressor is equipped with Automatic Reset Thermal Protector, and can automatically restart after the thermal protector resets. Always cut off power source when thermal protector becomes activated.
- Wear safety glasses or goggles when operating this product.
- Use only in well ventilated areas.

INSTALLATION

This air compressor is ideal for mounting under the hood or even inside your vehicle. The compact size of this compressor requires minimal space, and oil-less design permits mounting in many different areas of your vehicle. Please read and follow these Installation Instructions carefully to avoid injury or damage to the compressor or your vehicle.

Each of our air compressors and parts have been carefully produced and packaged. Before you begin installation, please familiarize yourself with Installation Parts List (Fig. 1) of this manual.

Guidelines for Selecting Mounting Location:

The selection of proper mounting location for your air compressor will help ensure a long and trouble free compressor service life. Please pay close attention to the following guidelines:

1. Select a FLAT, UPRIGHT AND SECURE location where the compressor can be mounted.
2. To maximize air compressor performance, locate compressor as CLOSE TO THE BATTERY as possible so that length of positive lead wire required is at a minimum.
3. Choose mounting location that is as cool as possible and AWAY FROM HEAT SOURCES. The cooler the ambient temperature the less chance the compressor will overheat.
4. This compressor is moisture & splash resistant, but NOT WATER PROOF. Do not mount compressor in locations where the unit is likely to come in contact with water.
5. Select compressor mounting location where air line can be routed from compressor air inlet to remote inlet air filter. Make sure Remote Inlet Air Filter is located in a dry location, away from water splashes.
6. You will also want to select a compressor mounting location where the leader hose bracket can be mounted to secure the 1.5 ft. leader hose.
7. If it is necessary to mount the air compressor further away from the battery, such as inside your vehicle or in the bed of your pickup, use a minimum 8 AWG positive lead wire for remote installation. (See wire gauge reference chart)
8. Do not mount compressor near areas where flammable liquids are stored.

MOUNTING AND WIRING

1. Disconnect ground cable from vehicle's battery.
2. Temporarily position the air compressor in the location where it will be mounted. Route the positive wire to the positive post of the battery. Measure and cut positive wire to the appropriate length and use appropriate inline fuse.
3. Route ground wire to the negative post of the battery or to an appropriate chassis grounding point and cut ground wire to length as needed.
4. Mount the air compressor by using the pair of anti-vibration mounting brackets and four sets of 13/64" (5mm) bolts, nuts, washers, and locking washers provided. Use 13/64" drill bit to drill holes for the first set of brackets. Mount this first bracket with screws, flat washers, locking washers and nuts provided. (Refer to Fig. 2 for placement of washers.)
5. Place compressor into mounted bracket. Place second set of bracket under the air compressor, make sure that the compressor sits snugly in between the two brackets. Mark off holes to be drilled using the second set of brackets as guides. Drill holes, and place compressor snugly between brackets and mount the second bracket.
6. Refer to Remote Air Filter Installation Instructions included in the Remote Inlet Air Filter Pack for installation of Remote Inlet Air Filter.
7. This air compressor comes equipped with a 1.5 ft. heavy duty heat resistant leader hose. This leader hose is designed to provide easy access for air hose attachment and to prolong the life of your extension hose as well as minimizing wear to the compressor air outlet. Do not remove this leader hose from the air compressor.
8. **PLEASE NOTE:** The leader hose that comes with your compressor may have a built-in inline check valve installed. Do not remove inline check valve from leader hose.
9. Select a proper location to mount leader hose with hose bracket provided. Avoid locations where leader hose may become tangled with wires and other hoses.
10. To mount hose bracket, drill hole with 3/16" drill bit and push self-anchoring hose bracket pin into hole. Route leader hose through hose bracket and secure hose by pressing bracket clamp into locked position.
11. To remove hose from the hose bracket, simply press down on the hose clamp release tab to release bracket clamp. (Fig. 3)
12. Attach ground wire to the negative post of the battery or chassis grounding point. Check to make sure that the air compressor's ON/OFF switch is in the OFF position. Attach positive wire to positive terminal of the battery.
13. Re-check to make sure that all connections are made securely.

(Fig. 1) 400H/450H Hardmount Air Compressor Kit Installation Parts List:

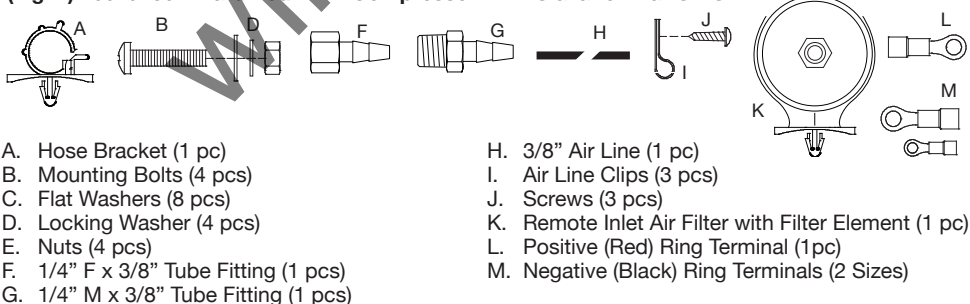

(Fig. 2) Compressor Mounting Hardware

- B. Mounting Bolt
- C. Flat Washer
- D. Locking Washer
- E. Nut
- F. Vibration Isolator

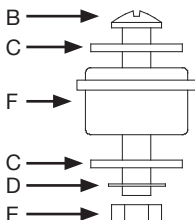

(Fig. 3) Leader Hose Bracket

- L. Hose Clamp
- M. Clamp Release Tab
- N. Self-Anchoring Pin

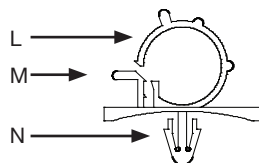

OPERATING INSTRUCTIONS

1. **IMPORTANT:** Always operate the compressor at or below the **MAXIMUM PRESSURE RATING** of the compressor. Please refer to Application & Specifications Sections of this manual for details.
2. Always observe the **MAXIMUM DUTY CYCLE** of the air compressor. Refer to Compressor Applications and Specifications Sections of this manual for details. Operation exceeding maximum pressure ratings and/or duty cycle will result in damage to the air compressor.
3. Your air compressor is equipped with an **AUTOMATIC THERMAL OVERLOAD PROTECTOR**. This feature is designed to protect the air compressor from overheating and causing permanent damage to your air compressor. The thermal overload protector will automatically cut power to your air compressor should the internal operating temperature of the air compressor rise above safe levels during excessive use.
4. Should at any time during use, your air compressor automatically shuts off; do not attempt to restart the air compressor. Turn power switch to the air compressor to the **OFF** position. The automatic thermal overload protector will automatically reset when internal temperature of the air compressor drops below safe levels. Allow air compressor to cool off for about 30 minutes, before resuming use of the air compressor.
5. Keep the vehicle engine running while using the air compressor to prevent discharge of your vehicle's battery.
6. **ONLY OPERATE THE AIR COMPRESSOR IN WELL-VENTILATED AREAS.**
7. Compressor performance is also enhanced when operating compressor with vehicle's engine running.

TIRE INFLATION

This air compressor comes with 1.5 feet heavy duty heat-resistant leader hose with 1/4" industrial series quick connect stud. By attaching an air hose with 1/4" industrial series quick coupler to the leader hose, your air compressor is ready to inflate tires. Read and follow tire inflation instructions carefully to avoid personal injury and damage to air compressor or vehicle.

1. Use heat-resistant, minimum 200PSI-rated working pressure extension hose. Do not use aftermarket hoses with less than 200PSI working pressure. Some aftermarket hoses may not be suitable for use with this air compressor due to heat and pressure typically generated by this type of air compressors.
2. Use of our convenient 25ft. extension coil hose with in-line deflator and Built-in Pressure Gauge is recommended (Part No. 00025, 5-in-1 Inline Inflator/Deflator).
3. Use of a close-ended tire chuck will cause excessive pressure buildup if tire chuck is not attached to tire valve stem while air compressor is in operation. Always use an Open-Ended tire chuck such as the tire chuck equipped on the Inflator/Deflator Coil Hose (P/N 00025) for tire inflation.
4. Always inflate tires to manufacturer's recommended tire pressures. Exercise extreme caution when driving with aired down tires. Re-inflate tires before high speed road way travel.

MAINTENANCE & REPAIRS

1. Periodically check all electrical and fitting connections. Clean and tighten or repair as needed.
2. Periodically check all mounting bolts. Tighten as needed.
3. Replace air filter element periodically. Replacement frequency depends on operating frequency and operating environment. For frequent use in dusty environment, we recommend that you replace air filter element at least once a month.
4. Regularly clean dust and dirt from compressor cooling fins and motor housing.
5. Your air compressor is equipped with a permanently lubricated, maintenance-free motor. Never try to lubricate compressor.
6. All repairs should be performed by Manufacturer or Manufacturer's Authorized Service Agencies only.

CAUTION: Never touch the air compressor or fittings connected to the air compressor, with bare hands during or immediately after usage. The leader hose and fittings connected to the leader hose will become very **HOT** during and after use. If necessary, wear heat resistant gloves to handle fittings, air line, and leader hose.

SPECIFICATIONS

- Part No. 40042 / 400H Air Compressor

Motor Voltage:	12 Volts
Max. Current Consumption:	26 Amps
Motor Type:	Permanent Magnetic
Max. Working Pressure:	150 PSI
Max. Duty Cycle (@ 72°F & 100 PSI):	33%
(Min. On/Off @72°F & 100 PSI)	15 On / 30 Off
Max. Restart Pressure:	150 PSI
Max. Ambient Temperature:	158°F
Min. Ambient Temperature:	-40°F
Fuse:	40 amps
Dimensions:	11.25"L x 4"W x 6.75H"
Net Weight:	8.95 Lbs.

- Part No. 45042 / 450H Air Compressor

Motor Voltage:	12 Volts
Max. Current Consumption:	19 Amps
Motor Type:	Permanent Magnetic
Max. Working Pressure:	150 PSI
Max. Duty Cycle (@ 72°F & 100 PSI):	100%
(Min. On/Off @72°F & 100 PSI)	Continuous
Max. Restart Pressure:	150 PSI
Max. Ambient Temperature:	158°F
Min. Ambient Temperature:	-40°F
Fuse:	30 amps
Dimensions:	12"L x 4"W x 6.75H"
Net Weight:	11.05 Lbs.

COMPRESSOR APPLICATION GUIDE

To ensure that you get the highest level of satisfaction from your compressor performance, refer to information below:

VIAIR COMPRESSOR REFERENCE CHART

COMPRESSOR SERIES	DUTY CYCLE	WORKING PRESSURE
100 SERIES	15%	130 PSI
215 SERIES	17%	150 PSI
225 SERIES	20%	150 PSI
265 SERIES	22%	150 PSI
275 SERIES	25%	150 PSI
300 SERIES	30%	150 PSI
400 SERIES	33%	150 PSI
450 SERIES	100%	150 PSI
500 SERIES	33%	150 PSI
550 SERIES	100%	150 PSI

ABOUT COMPRESSOR DUTY CYCLE:

Compressor Duty Cycle refers to amount of time a compressor can be operated in a given time period, at 100 PSI & at a standard ambient temperature of 72°F.

Duty Cycle is commonly expressed as:

Compressor On Time / (Compressor On Time + Off Time)

As an example, a compressor that is rated for 20% duty cycle means that compressor can be operated at 100 PSI @ 72°F for 8 Minutes and rested for 32 Minutes.

8 min. on / (8 min. on + 32 min. off) = 20% Duty Cycle

DUTY CYCLE REFERENCE CHART

DUTY CYCLE @100PSI / 72°F	MINUTES ON / OFF
15%	6 Min. On / 34 Min. Off
17%	7 Min. On / 30 Min. Off
20%	8 Min. On / 32 Min. Off
22%	9 Min. On / 30 Min. Off
25%	10 Min. On / 30 Min. Off
30%	13 Min. On / 30 Min. Off
33%	15 Min. On / 30 Min. Off
100%	Continuous Duty

ABOUT RATED WORKING PRESSURE:

To ensure trouble free service life of your compressor, always operate compressor within rated working pressure of the compressor. Never use a pressure switch with a higher cut-off pressure than compressor's rated working pressure.

Online-store car audio and autogoods Winauto

400H - 450H Air Compressor Kit

TROUBLESHOOTING GUIDE:

PROBLEM:	POSSIBLE CAUSE(S)	CORRECTIVE ACTION
Tank pressure drops when compressor(s) shut off	<ol style="list-style-type: none">1. Loose drain cock2. Check valve leaking3. Loose connections	<ol style="list-style-type: none">1. Tighten drain cock2. Replace check valve or compressor3. Check all connections with soap and water solution and tighten
Compressor runs continuously and air flow lower than normal	<ol style="list-style-type: none">1. Excessive air usage2. Loose connections3. Worn piston ring or inlet valve.4. Clogged air filter element	<ol style="list-style-type: none">1. Decrease air usage2. Check all connections with soap and water solution and tighten.3. Replace compressor4. Replace air filter element
Compressor runs continuously causing safety valve (if equipped) to open	<ol style="list-style-type: none">1. Faulty pressure switch2. Defective safety valve	<ol style="list-style-type: none">1. Replace pressure switch2. Replace safety valve
Excessive moisture in discharge	<ol style="list-style-type: none">1. Excessive water in air tank2. High humidity	<ol style="list-style-type: none">1. Drain tank, tilt tank to drain. Drain tank more frequently2. Move compressor to area with less humidity, or use water separator
Compressor will not run	<ol style="list-style-type: none">1. No power, or power switch in OFF position2. Blown fuse3. Motor overheats4. Faulty pressure switch (if hooked up to a pressure switch).	<ol style="list-style-type: none">1. Make sure compressor switch is ON2. Disconnect compressor from power source, replace fuse. (Refer to Specifications section for correct fuse amperage)3. Let compressors cool off for about 30 minutes to allow thermal overload switch to reset.4. Replace pressure switch
Thermal overload protector cuts out repeatedly	<ol style="list-style-type: none">1. Lack of proper ventilation or ambient temperature is too high2. Compressor valves failed	<ol style="list-style-type: none">1. Move compressor to well ventilated area, or area with lower ambient temperature2. Replace compressor
Excessive knocking or rattling	<ol style="list-style-type: none">1. Loose mounting bolts2. Worn bearing on eccentric or motor shaft3. Cylinder or piston ring is worn	<ol style="list-style-type: none">1. Tighten bolts2. Replace bearing or piston assembly3. Replace piston or compressor

CAUTION: NEVER DISASSEMBLE COMPRESSOR WHILE COMPRESSOR IS PRESSURIZED.

400H - 450H Air Compressor Kit

WIRE GAUGE GUIDE 12-VOLT:

Amp Draw	Length of wire from battery to compressor				
	10	15	20	25	30
10	14	12	10	10	10
15	12	10	10	8	8
20	10	10	8	6	6
25	10	8	6	6	6
30	10	8	6	6	4
40	8	6	6	4	4
50	6	6	4	4	2
60	6	4	4	2	2

Wiring Diagram:

(Fuse Not Included)

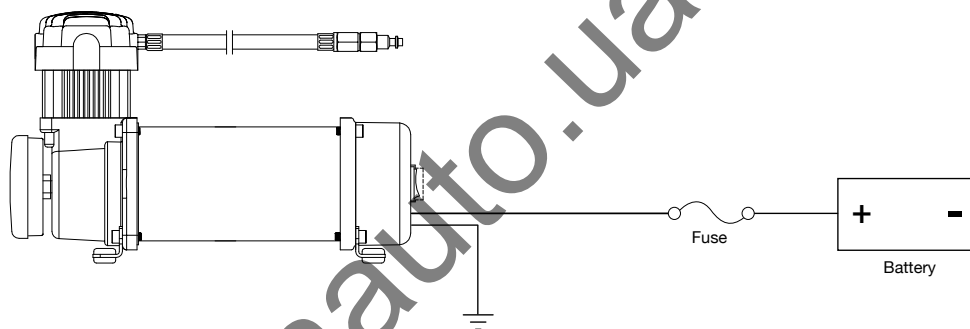

LIMITED WARRANTY:

VIAIR Corporation warrants this product, when properly installed and under normal conditions of use, to be free from defects in workmanship and materials for a period of one year from its original date of purchase. To receive warranty service or repair, please contact VIAIR Corporation.

Returns should be made within one year of the date of purchase, after a Return Goods Authorization (RGA) number has been assigned by VIAIR Corporation. To obtain RGA, fax a copy of your receipt to (949) 585-0188. For complete warranty details, please visit: www.viaircorp.com/warranty

PLEASE NOTE:

THIS WARRANTY COVERS PRODUCT DEFECTS ONLY; IT DOES NOT COVER INCIDENTAL OR CONSEQUENTIAL DAMAGES AS RESULT OF MISUSE OR ABUSE.



15 EDELMAN • IRVINE, CA 92618
TEL: (949) 585-0011 • FAX: (949) 585-0188
www.viaircorp.com