

NRG-2Q Series



User's Manual

Two Quadrant, Regenerative PWM Drives
for DC Brush Motors

Copyright © 2001 by Minarik Corporation

All rights reserved. No part of this manual may be reproduced or transmitted in any form without written permission from Minarik Corporation. The information and technical data in this manual are subject to change without notice. Minarik Corporation and its Divisions make no warranty of any kind with respect to this material, including, but not limited to, the implied warranties of its merchantability and fitness for a given purpose. Minarik Corporation and its Divisions assume no responsibility for any errors that may appear in this manual and make no commitment to update or to keep current the information in this manual.

Printed in the United States of America.

Safety Warnings



- This symbol  denotes an important safety tip or warning. Failure to heed these warnings may result in damage to the drive or personal injury. **Please read these instructions carefully** before performing any of the procedures contained in this manual.
- **DO NOT INSTALL, REMOVE, OR SERVICE THIS EQUIPMENT WITH POWER APPLIED.** Have a qualified electrical technician install, adjust and service this equipment. Follow the National Electrical Code and all other applicable electrical and safety codes, including the provisions of the Occupational Safety and Health Act (OSHA), when installing equipment.
- Reduce the chance of an electrical fire, shock, or explosion by proper grounding, over-current protection, thermal protection, and enclosure. Follow sound maintenance procedures.



It is possible for a drive to run at full speed as a result of a component failure. Minarik strongly recommends the installation of a master switch in the main power input to stop the drive in an emergency.

Circuit potentials are at 115 VAC or 230 VAC above earth ground. Avoid direct contact with the printed circuit board or with circuit elements to prevent the risk of serious injury or fatality. Use a non-metallic screwdriver for adjusting the calibration trimpots. Use approved personal protective equipment and insulated tools if working on this drive with power applied.

Contents

Specifications	1
NRG02–D240AC–2Q	1
NRG05–D240AC–2Q	2
NRG10–115AC–2Q	3
Dimensions	4
Regenerative Drives	5
Installation	7
Drive mounting	7
Wiring	8
Shielding guidelines	9
Line fusing	10
Connections	11
Motor connections	11
Power lead connections	12
Dynamic brake resistor connections	12
Inhibit personality header	14
+12 VDC terminals	14
Voltage follower connection	16
Operation	17
Before applying power	17
Startup and shutdown	18
Starting and stopping methods	19
Line starting and stopping	20
Decelerating to minimum speed	21
Inhibit terminals	22
Dynamic braking	23

Calibration	26
Calibration procedure	.28
MINIMUM SPEED (MIN)	.29
MAXIMUM SPEED (MAX)	.29
REGULATION (IR COMP)	.30
MOTOR CURR. LIMIT and REGEN CURR. LIMIT	.31
ACCEL	.32
DECEL	.33
Application Notes	35
Connection to other Minarik devices	.35
Optional speed adjust potentiometer connections	.36
Multiple fixed speeds	.36
Adjustable speeds using potentiometers in series	.37
Independent adjustable speeds	.38
RUN/JOG switch	.39
RUN/JOG option #1	.39
RUN/JOG option #2	.40
Leader-follower application	.41
Single speed potentiometer control of multiple drives	.42
Troubleshooting	43
Before troubleshooting	.43
Diagnostic LEDs	.44
Power	.44
Motor Output	.44
Regen Output	.44
Replacement Parts	.49
Unconditional Warranty	inside back cover

Illustrations

Figure 1. NRG-2Q Dimensions	4
Figure 2. Two Quadrant Operation	6
Figure 3. NRG-2Q Connections	13
Figure 4. Inhibit Personality Header, Inhibit Terminals and +12 VDC Terminals	15
Figure 5. Voltage Follower Connections	16
Figure 6. Connections for Run/Decelerate to Minimum Speed Switch	21
Figure 7. Dynamic Braking Circuit Connection	25
Figure 8. Calibration Trimpot Layout	27
Figure 9. Typical IR COMP and CURRENT LIMIT settings	34
Figure 10. NRG-2Q Connection to DLC600 DIGI-LOK Control and PCM4 Signal Isolator	35
Figure 11. Multiple Fixed Speeds	36
Figure 12. Adjustable Fixed Speeds Using Potentiometers in Series	37
Figure 13. Independent Adjustable Speeds	38
Figure 14. RUN/JOG Switch Connection to Inhibit Plug	39
Figure 15. RUN/JOG Switch Connection to Speed Adjust Potentiometer	40
Figure 16. Leader-Follower Application	41
Figure 17. Single Speed Potentiometer Control of Multiple Drives	42
Figure 18. Diagnostic LED Location	44

Tables

Table 1. Recommended Line Fuse Sizes	10
Table 2. Inhibit Plug Harness Assembly Part Number	22

Specifications

Model Number	NRG02-D240AC-2Q
Type	Open Chassis
AC Line Voltage	115 VAC or 230 VAC, $\pm 10\%$, 50Hz or 60 Hz, single phase
Maximum Continuous Armature Current	2 ADC
Horsepower Range @ 130 VDC Output	1/20 – 1/4
Horsepower Range @ 240 VDC Output	1/10 – 1/2
Maximum Armature Voltage Range @ 115 VAC Input	0–130 VDC
Maximum Armature Voltage Range @ 230 VAC Input	0–240 VDC
Form Factor	1.03
Acceleration Time Range	1–10 seconds
Deceleration Time Range	1–10 seconds
Input Signal Range (signal must be isolated)	0–5 VDC
Input Impedance	100K ohms minimum
Speed Regulation (% of base speed)	1% open loop
Speed Range	100:1
Vibration	0.5G max. (0–50 Hz); 0.1G max. (>50 Hz)
Weight	1.94 lb
Ambient Operating Temperature Range	10°C–40°C

Model Number NRG05–D240AC–2Q

Type	Open Chassis
AC Line Voltage	115 VAC or 230 VAC, $\pm 10\%$, 50Hz or 60 Hz, single phase
Maximum Continuous Armature Current	5 ADC
Horsepower Range @ 130 VDC Output	1/8 – 3/4
Horsepower Range @ 240 VDC Output	1/4 – 1 1/2
Maximum Armature Voltage Range @ 115 VAC Input	0–130 VDC
Maximum Armature Voltage Range @ 230 VAC Input	0–240 VDC
Form Factor	1.03
Acceleration Time Range	1–10 seconds
Deceleration Time Range	1–10 seconds
Input Signal Range (isolated)	0–5 VDC
Input Impedance	100K ohms minimum
Speed Regulation (% of base speed)	1% open loop
Speed Range	100:1
Vibration	0.5G max. (0–50 Hz); 0.1G max. (>50 Hz)
Weight	1.94 lb
Ambient Operating Temperature Range	10°C–40°C

Model Number NRG10–115AC–2Q

Type	Open Chassis
AC Line Voltage	115 VAC, $\pm 10\%$, 50Hz or 60 Hz, single phase
Maximum Continuous Armature Current	10 ADC
Horsepower Range @ 130 VDC Output	1/4 – 1 1/2
Maximum Armature Voltage Range	0–130 VDC
Form Factor	1.03
Acceleration Time Range	1–10 seconds
Deceleration Time Range	1–10 seconds
Input Signal Range (isolated)	0–5 VDC
Input Impedance	100KW minimum
Speed Regulation (% of base speed)	1% open loop
Speed Range	100:1
Vibration	0.5G max. (0–50 Hz); 0.1G max. (>50 Hz)
Weight	1.94 lb
Ambient Operating Temperature Range	10°C–40°C

Dimensions

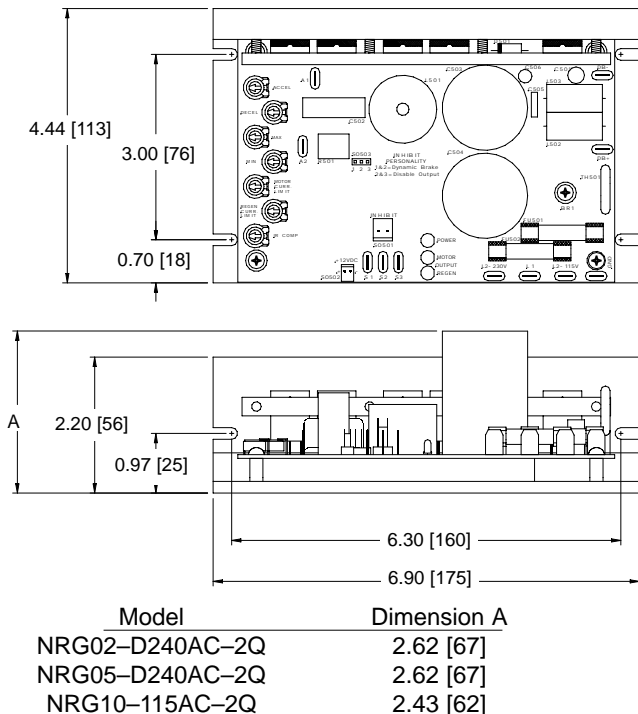

All dimensions in inches [millimeters]

Figure 1. NRG-2Q Dimensions

Regenerative Drives

Most non-regenerative, variable speed, DC drives control current flow to a motor in one direction. The direction of current flow is the same direction as the motor rotation. Non-regenerative drives operate in Quadrant 1 (see Figure 2, page 6). Unless dynamic braking is used, non-regenerative drives decelerate a load faster than coasting to a lower speed.

NRG-2Q drives operate in Quadrants 1 and 4. In Quadrant 4, the direction of current flow is in the opposite direction of motor rotation. This allows regenerative drives to control an overhauling load and decelerate a load faster than it would take to coast to a lower speed.

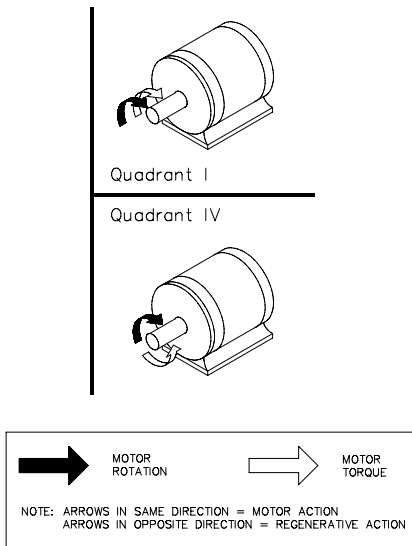

Figure 2. Two Quadrant Operation

Installation

Drive mounting



Warning

Do not install, rewire, or remove this control with power applied. Doing so may cause fire or serious injury. Make sure you have read and understood the Safety Warnings before attempting installation.

The chassis must be earth grounded. Use a star washer beneath the head of at least one of the mounting screws to penetrate the anodized chassis surface and to reach bare metal.

- Drive components are sensitive to electrostatic fields. Avoid contact with the circuit board directly. Hold drive by the chassis only.
- Protect the drive from dirt, moisture, and accidental contact. Provide sufficient room for access to the terminal block and calibration trimpots.
- Mount the drive away from other heat sources. Operate the drive within the specified ambient operating temperature range.
- Prevent loose connections by avoiding excessive vibration of the drive.
- Mount drive with its board in either a horizontal or vertical plane. Six 0.19 inch (5 mm) wide slots in the chassis accept #8 pan head screws. Fasten either the large base or the flange of the chassis to the subplate.

Wiring



Warning



Do not install, remove, or rewire this equipment with power applied. Failure to heed this warning may result in fire, explosion, or serious injury.

Circuit potentials are at 115 or 230 VAC above ground. To prevent the risk of injury or fatality, avoid direct contact with the printed circuit board or with circuit elements.

Do not disconnect any of the motor leads from the drive unless power is removed or the drive is disabled. Opening any one motor lead may destroy the drive.

Use 16 AWG wire for AC line voltage (L1 and L2) and motor armature (A1 and A2) wiring. Use 18 AWG wire for logic (inhibit leads or S1, S2 and S3). For the dynamic brake resistor, use 14 AWG wire for model NRG10-115AC-2Q, or 16 AWG wire for models NRG05-D240AC-2Q and NRG02-D240AC-2Q.

Shielding guidelines



Warning

Under no circumstances should power and logic leads be bundled together. Induced voltage can cause unpredictable behavior in any electronic device, including motor controls.

As a general rule, Minarik recommends shielding of all conductors.

If it is not practical to shield power conductors, Minarik recommends shielding all logic-level leads. If shielding logic leads is not practical, the user should twist all logic leads with themselves to minimize induced noise.

It may be necessary to earth ground the shielded cable. If noise is produced by devices other than the drive, ground the shield at the drive end. If noise is generated by a device on the drive, ground the shield at the end away from the drive. Do not ground both ends of the shield.

If the drive continues to pick up noise after grounding the shield, it may be necessary to add AC line filtering devices, or to mount the drive in a less noisy environment.

Line fusing

NRG Series drives have preinstalled line fuses. See the Replacement Parts section for preinstalled line fuse size. When replacing the line fuses, use fast acting fuses rated for 250 VAC or higher, and approximately 150% of the armature current. Two line fuses are required for models NRG02–D240AC–2Q and NRG05–D240AC–2Q, while only one is required for model NRG10–115AC–2Q. See Table 1 for recommended line fuse sizes.

Table 1. Recommended Line Fuse Sizes

90 VDC Motor Horsepower	180 VDC Motor Horsepower	Max. DC Armature Current (amps)	AC Line Fuse Size (amps)
1/20	1/10	0.5	3
1/15	1/8	0.8	3
1/8	1/4	1.5	5
1/6	1/3	1.7	5
1/4	1/2	2.6	8
1/3	3/4	3.5	8
1/2	1	5.0	10
3/4	1 1/2	7.6	15
1	2	10	20

Minarik Corporation offers two fuse kits: part number 050–0069 (3–8A Fuse Kit) and 050–0073 (5–20A Fuse Kit). See *Replacement Parts* (page 49) for fuse kit contents.

Connections



Warning

Do not connect this equipment with power applied. Failure to heed this directive may result in fire or serious injury.

Minarik strongly recommends the installation of a master power switch in the voltage input line. The switch contacts should be rated at a minimum of 200% of motor nameplate current and 250 volts.

Connect the power input leads and a DC motor to the drive's printed circuit board (PCB) as shown in Figure 3 (page 13).

Motor connections

Minarik drives supply motor voltage from A1 and A2 terminals. It is assumed throughout this manual that, when A1 is positive with respect to A2, the motor will rotate clockwise (CW) while looking at the output shaft protruding from the front of the motor. If this is opposite of the desired rotation, simply reverse the wiring of A1 and A2 with each other.

Connect a DC motor to PCB terminals A1 and A2 as shown in Figure 3. **Ensure that the motor voltage rating is consistent with the drive's output voltage.**

Power lead connections

Connect the AC line power leads to TB501 terminals L1 and L2, or to a double-throw, single-pole master power switch (recommended).

Dynamic brake resistor connections

If you plan to use dynamic braking to stop the motor, you must connect a dynamic brake resistor across the DB+ and DB- terminals on the PCB as shown in Figure 3.

The dynamic brake resistor reduces the voltage across the bus capacitors (C503 and C504) when they reach their maximum voltage rating. This occurs when the motor regenerates voltage back to the drive. Bus capacitor maximum voltage ratings are 400 VDC for 240 VAC drives, and 200 VDC for 115 VAC drives.

For more information on dynamic braking, as well as selecting dynamic brake resistor values, refer to the *Dynamic Braking* section on page 23.

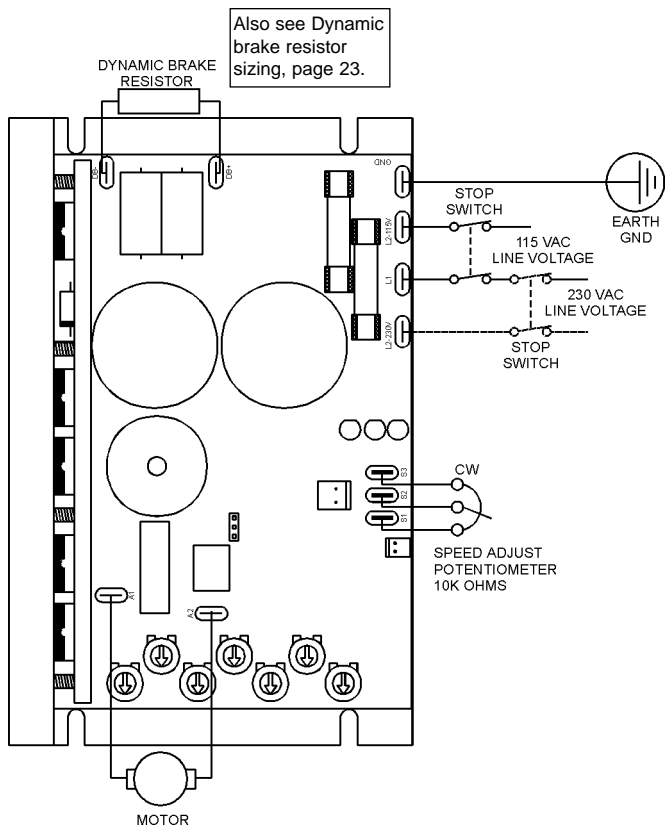
**Figure 3. NRG-2Q Connections**

Inhibit personality header

The inhibit personality header (SO503) determines how the drive responds when the INHIBIT terminals (SO501) are shorted together. Set the inhibit personality before shorting the inhibit terminal to each other. Jumper pins 1 and 2 for a dynamic brake response, or pins 2 and 3 for a disable output response (coast to a stop). (Also read *Inhibit terminals* section on page 22). See Figure 4 for jumper and inhibit terminal locations.

+12 VDC terminals

To supply power to external devices, the +12VDC terminals can supply an unregulated +12 VDC (30 mA) signal. – is the signal common terminal, and + is the voltage signal terminal. See Figure 4 for terminal location.

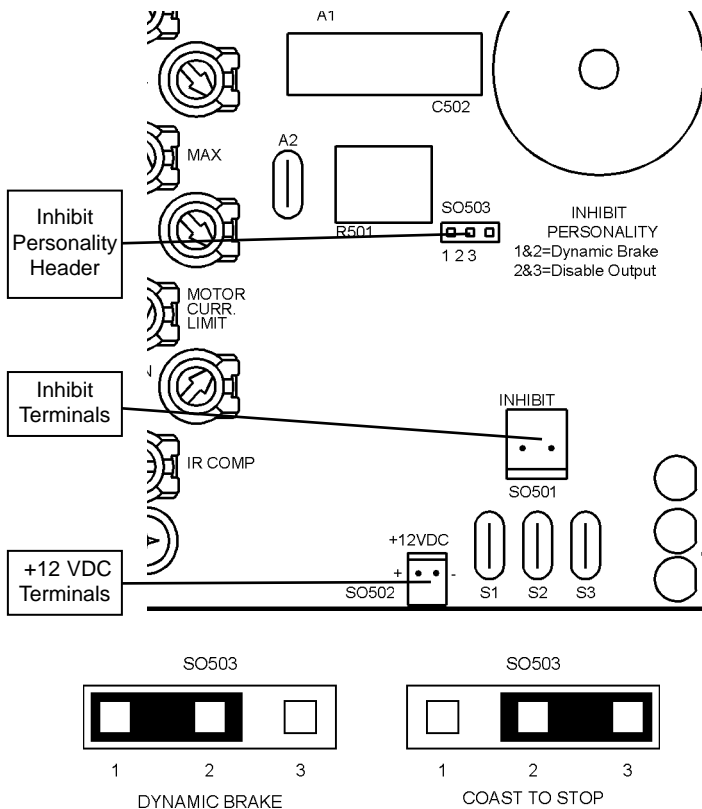

Figure 4. Inhibit Personality Header, Inhibit Terminals, and +12 VDC Terminals

Voltage follower connection

Instead of using a speed adjust potentiometer to set motor speed, the drive may follow a floating (isolated) 0 to +5 VDC signal. Connect the signal input to S2, and signal common to S1. Make no connection to S3. See Figure 5.

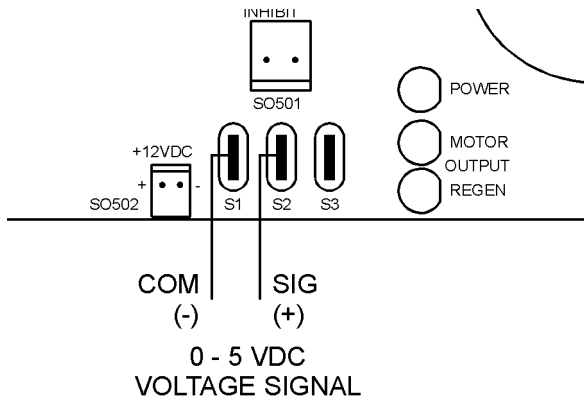

Figure 5. Voltage Follower Connections

Operation



Warning

Dangerous voltages exist on the drive when it is powered, and up to 30 seconds after power is removed and the motor stops. BE ALERT. High voltages can cause serious or fatal injury.

Before applying power

- Verify that no conductive material is present on the printed circuit board.
- Set all switches and jumpers to their proper settings.
- Verify that the AC supply is properly balanced.

Startup and shutdown

1. Set the speed adjust potentiometer for zero speed (full CCW).
If the drive is following a voltage signal, set the voltage signal to 0 VDC.
2. Apply AC line voltage.
3. Rotate the speed adjust potentiometer or increase the voltage signal until the desired speed is reached.
4. Remove AC line voltage from the drive to coast the motor to a stop.

Starting and stopping methods



Warning

Decelerating to minimum speed, regenerative braking, or coasting to a stop is recommended for frequent starts and stops. Do not use any of these methods for emergency stopping. They may not stop a drive that is malfunctioning. Removing AC line power (both L1 and L2) is the only acceptable method for emergency stopping.

Frequent decelerating to minimum speed, regenerative braking, or coasting to a stop produces high torque. This may cause damage to motors, especially gearmotors that are not properly sized for the application.

The 230 VAC line, if used, must be balanced. Contact your local distributor for line-balancing circuitry.

Logic wires from other input devices, such as motion controllers and PLL velocity controllers must be separated from power lines in the same manner as the logic I/O on this drive.

Line starting and stopping

When AC line voltage is applied to the drive, the motor accelerates to the set speed. When AC line voltage is removed, the motor coasts to a stop. Line stopping (removing AC line voltage) is recommended for stopping in emergency situations only. It is not recommended for frequent starting and stopping.

For this reason, Minarik strongly recommends that you install a stop switch on the line voltage inputs (both L1 and L2). Refer to Figure 3 (page 13).

Automatic restart of the drive

When line voltage is applied to the drive, the motor will automatically accelerate to the speed commanded by the speed adjust potentiometer or reference signal. Wiring a latching relay into the motor control circuit is one way to prevent undesirable restarts.

Decelerating to minimum speed

Shorting terminal S2 to S1 decelerates the motor to minimum speed (Figure 6). The ACCEL and DECEL trimpots determine the rate of acceleration and deceleration, respectively. Set the minimum speed by calibrating the MIN trimpot. See **Calibration** on page 26 for specific calibration instructions

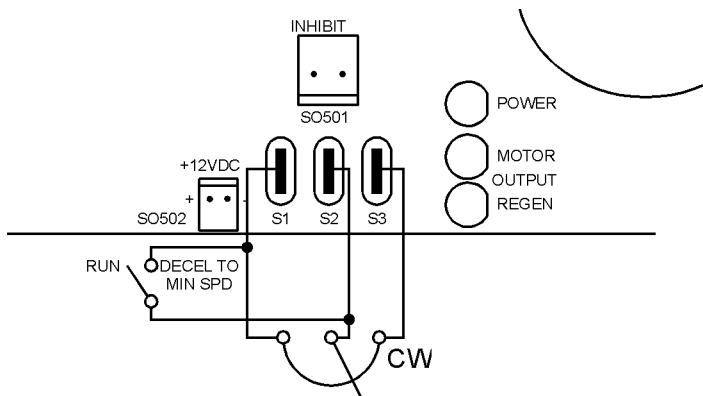

Figure 6. Connections for Run/Decelerate to Minimum Speed Switch

Inhibit terminals

Shorting the inhibit terminals (SO501) to each other causes the motor to either coast to a stop or brake to a stop. First set the inhibit personality to coasting or braking to a stop (see Inhibit personality on page 14). Next, short the inhibit pins to coast or brake to a stop. Remove the short to accelerate the motor to set speed.

Minarik Corporation offers two accessory plug harnesses for use with the Inhibit terminals:

Table 2. Inhibit Plug Harness Assembly Part Number

Minarik Part Number	Description
201-0024	Inhibit plug with 18 in. (46 cm) wires
201-0079	Inhibit plug with 36 in. (91 cm) wires

Twist inhibit plug wires and separate them from other power-carrying wires or sources of electrical noise. Use shielded cable if the inhibit plug wires are longer than 12 inches (30 cm). If shielded cable is used, ground only one end of the shield to earth ground. Do not ground both ends of the shield.

Dynamic braking



Warning

Wait for the motor to completely stop before switching it back to RUN. This will prevent high armature currents from damaging the motor or drive.

Inhibit personality header SO503 must be set to BRAKE for dynamic brake operation. See Figure 7, page 25.

Dynamic braking may be used to rapidly stop a motor (Figure 7, page 25). Connect a RUN/BRAKE switch to the INHIBIT terminals. Connect a dynamic brake resistor to the DB+ and DB- terminals on the printed circuit board. See Figure 3 on page 13 for dynamic brake resistor connections.

Dynamic brake resistor

The dynamic brake resistor reduces the voltage across the bus capacitors (C503 and C504) when they reach their maximum voltage rating. This occurs when the motor regenerates voltage back to the drive. Bus capacitor maximum voltage ratings are 400 VDC for 240 VAC drives, and 200 VDC for 115 VAC drives.

Dynamic brake resistor value

Use a 40-ohm dynamic brake resistor for models NRG02-D240AC-2Q and NRG05-D240AC-2Q. Use a 20-ohm dynamic brake resistor for model NRG10-115AC-2Q. The dynamic brake resistor tolerance is $\pm 10\%$.

Dynamic brake resistor power rating

Use the following equation to determine the dynamic brake resistor power rating:

$$\begin{aligned} \text{DBwatts} &= (\text{Motor Power watts} \times \text{duty cycle}) \times 1.2 \\ &= [(\text{Horsepower} \times 746) \times \text{duty cycle}] \times 1.2 \end{aligned}$$

$$\text{duty cycle} = \frac{T_{\text{REGEN}}}{T_{\text{MOTOR}} + T_{\text{REGEN}}}$$

where T_{REGEN} is the amount of time the motor is generating voltage back into the drive, and T_{MOTOR} is the amount of time the drive is generating voltage into the motor. The absolute minimum dynamic brake resistor power rating is typically 100 watts.

Example:

Size a DB resistor for a 1 HP motor that has a 50% duty cycle. It will be used with model NRG05–D240AC–2Q.

Solution:

Use a 40 ohm resistor with a minimum power rating of at least 448 watts.

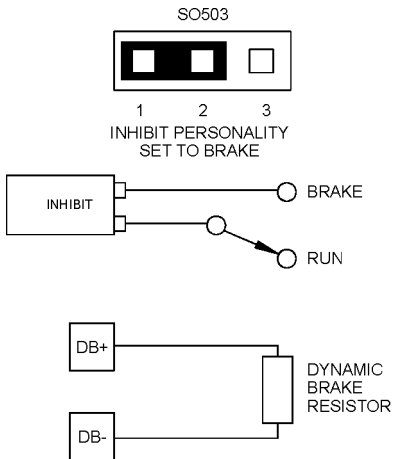

Figure 7. Dynamic Braking Circuit Connection

Calibration



Warning

Dangerous voltages exist on the drive when it is powered, and up to 30 seconds after power is removed and the motor stops. When possible, disconnect the voltage input from the drive before adjusting the trimpots. If the trimpots must be adjusted with power applied, use insulated tools and the appropriate personal protection equipment. **BE ALERT.** High voltages can cause serious or fatal injury.

NRG-2Q Series drives have seven user-adjustable trimpots. Each drive is factory calibrated to its maximum current rating. Readjust the calibration trimpot settings to accommodate lower current motors. See Figure 8 for trimpot location.

All adjustments increase with CW rotation and decrease with CCW rotation. Use a non-metallic screwdriver for calibration. Each trimpot is identified on the printed circuit board.

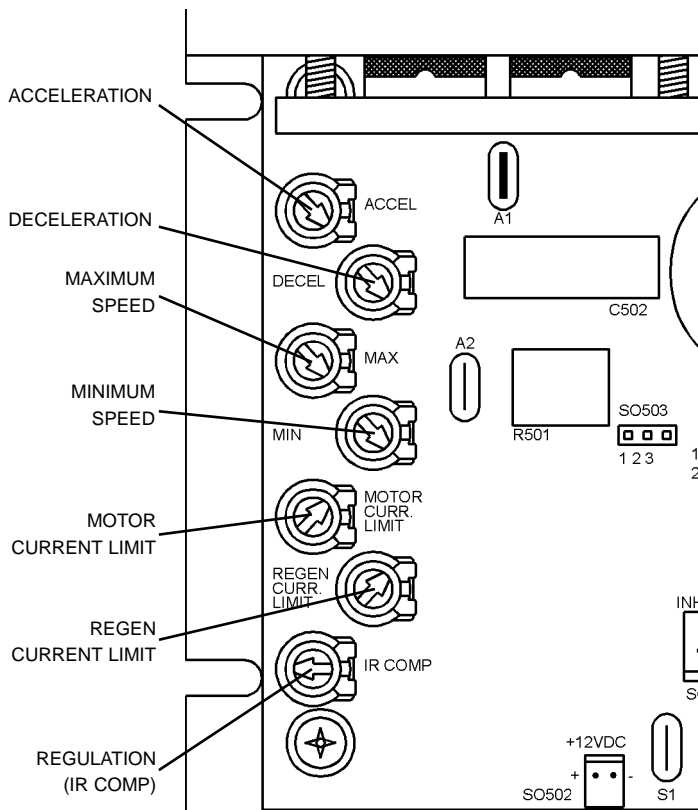

Figure 8. Calibration Trimpot Layout

Calibration procedure

Calibrate the drive using the following procedure:

1. Set the MIN SPD, MAX SPD, ACCEL and DECEL trimpots to zero (full CCW).
2. Set the MOTOR CURRENT LIMIT and REGEN CURRENT LIMIT trimpots to maximum (full CW).
3. Set the IR COMP trimpot to midrange (approximate 12 o'clock position).
4. Set the signal input (analog voltage signal or speed adjust potentiometer) to zero.
5. Apply power to the drive.
6. Calibrate the trimpots as follows:

MINIMUM SPEED (MIN)

The MIN setting determines the minimum speed when the speed adjust potentiometer or voltage input signal is set for minimum speed. It is factory set to zero speed.

To calibrate MIN:

1. Set the MIN trimpot CCW.
2. Set the speed adjust potentiometer or voltage input signal for minimum speed.
3. Adjust the MIN trimpot to the desired minimum speed.

MAXIMUM SPEED (MAX)

The MAX setting determines the maximum motor speed when the speed adjust potentiometer or voltage input signal is set for maximum speed. It is factory set for maximum rated motor speed.

To calibrate MAX:

1. Set the MAX trimpot full CCW.
2. Set the speed adjust potentiometer or voltage input signal for maximum speed.
3. Adjust the MAX trimpot to the desired maximum speed.

REGULATION (IR COMP)

The IR COMP setting determines the degree to which motor speed is held constant as the motor load changes. It is factory set for optimum motor regulation at maximum rated current.

To calibrate IR COMP (exact calibration):

1. Turn the IR COMP trimpot full CCW.
2. Set the speed adjust potentiometer or voltage input signal until the motor runs at midspeed without load (for example, 900 RPM for an 1800 RPM motor). Use a hand held tachometer to measure motor speed.
3. Load the motor armature to its full load armature current rating. The motor should slow down.
4. While keeping the load on the motor, rotate the IR COMP trimpot until the motor runs at the speed measured in step 2.

Approximate calibration:

If the motor does not maintain set speed as the load changes, gradually rotate the IR COMP trimpot CW. If the motor oscillates (overcompensation), the IR COMP trimpot may be set too high (CW). Turn the IR COMP trimpot CCW to stabilize the motor. See Figure 9, page 34 for recommended IR COMP trimpot settings.

MOTOR CURR. LIMIT and REGEN CURR. LIMIT



Warning

Although CURRENT LIMIT is set to 120% of motor nameplate current rating, continuous operation beyond that rating may damage the motor. If you intend to operate beyond the rating, contact your Minarik representative for assistance.

The MOTOR CURR. LIMIT setting determines the maximum current limit for accelerating and driving the motor. The REGEN CURR. LIMIT setting determines the maximum current limit for decelerating and stopping the motor. Both CURRENT LIMIT trimpots are factory set at approximately 120% of maximum drive current and must be recalibrated when using a lower current motor. See Figure 9, page 34, for recommended CURRENT LIMIT trimpot settings.

To calibrate the CURRENT LIMIT trimpots:

1. With the power disconnected from the drive, connect a DC ammeter in series with the armature.
2. Set the MOTOR CURR. LIMIT trimpot to minimum (full CCW).
3. Lock the motor armature. Be sure that the motor is firmly mounted.
4. Connect power to the drive. The motor should remain stopped.

5. Set the speed adjust potentiometer or voltage input signal for maximum forward speed.
6. Slowly adjust the MOTOR CURR. LIMIT trimpot CW until the armature current is 120% of motor rated current.
7. Set the REGEN CURR. LIMIT trimpot to approximately the same setting as the MOTOR CURR. LIMIT.
8. Set the speed adjust potentiometer or voltage input signal for zero speed
9. Remove AC power.
10. Remove the stall from the motor.

ACCEL

The ACCEL setting determines the time the motor takes to ramp to a higher speed. ACCEL is factory set for the fastest acceleration time (full CCW).

To calibrate ACCEL:

1. Set the speed adjust potentiometer or voltage input signal to zero speed. The motor should run at minimum speed.
2. Set the speed adjust potentiometer or voltage input signal to maximum forward speed, and measure the time it takes the motor to go from minimum to maximum speed.
3. If the time measured in step 2 is not the desired acceleration time, turn the ACCEL trimpot CW for a slower acceleration time, or CCW for a faster acceleration time. Repeat steps 1 through 3 until the acceleration time is correct.

DECEL

The DECEL setting determines the time the motor takes to ramp to a lower speed. DECEL is factory set for the fastest deceleration time (full CCW).

To calibrate DECEL:

1. Set the speed adjust potentiometer or voltage input signal to maximum forward speed. The motor should run at maximum speed.
2. Set the speed adjust potentiometer or voltage input signal to minimum speed and measure the time it takes the motor to go from maximum to minimum speed.
3. If the time measured in step 2 is not the desired deceleration time, turn the DECEL trimpot CW for a slower deceleration time, or CCW for a faster deceleration time. Repeat steps 1 through 3 until the deceleration time is correct.

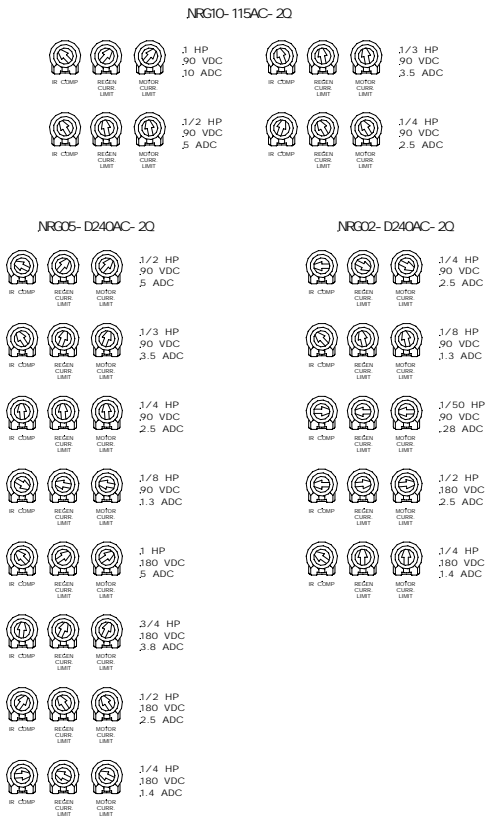

**Figure 9. Typical IR COMP and CURRENT LIMIT settings
(actual settings may vary)**

Application Notes

Connection to other Minarik devices

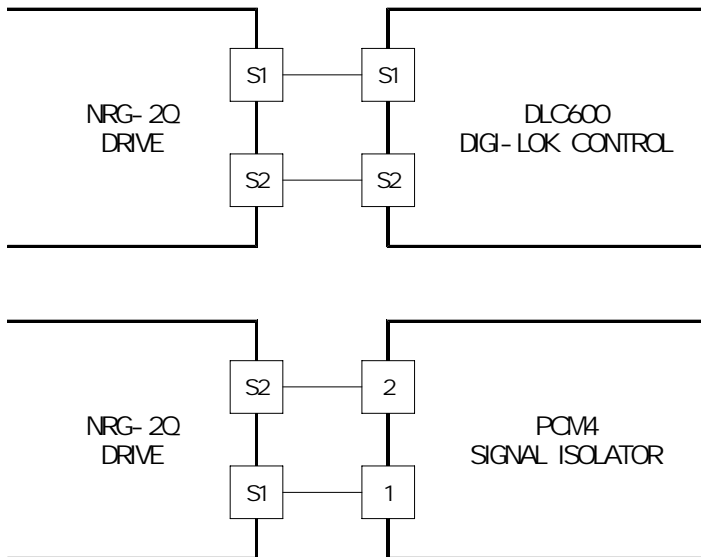

Figure 10. NRG-2Q Connection to DLC600 DIGI-LOK Control and PCM4 Signal Isolator

Optional speed adjust potentiometer connections

Multiple fixed speeds

Replace the speed adjust potentiometer with series resistors with a total series resistance of 10K ohms (Figure 11). Add a single pole, multi-position switch with the correct number of positions for the desired number of fixed speeds.

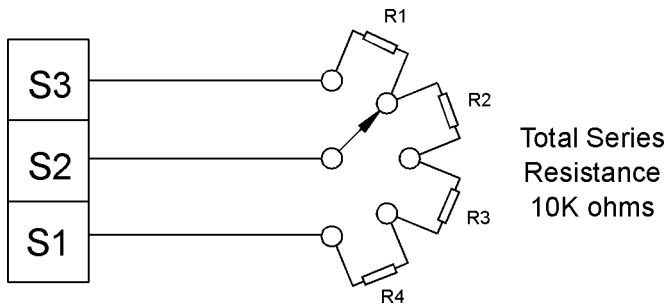

Figure 11. Multiple Fixed Speeds

Adjustable speeds using potentiometers in series

Replace the speed adjust potentiometer with a single pole, multi-position switch, and two or more potentiometers in series, with a total series resistance of 10K ohms. Figure 12 shows a connection for fixed high and low speed adjust potentiometers.

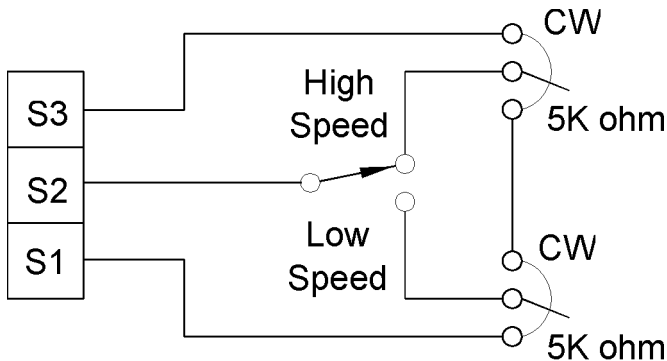

Figure 12. Adjustable Fixed Speeds Using Potentiometers in Series

Independent adjustable speeds

Replace the speed adjust potentiometer with a single pole, multi-position switch, and two or more potentiometers in parallel, with a total parallel resistance of 10K ohms. Figure 13 shows the connection of two independent speed adjust potentiometers that can be mounted at two separate operating stations.

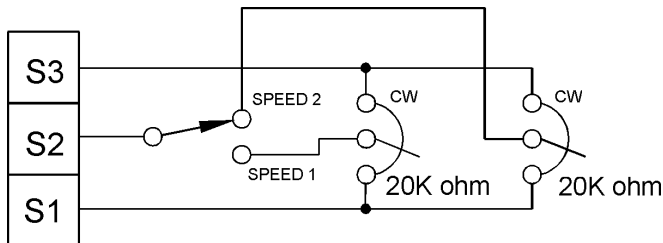

Figure 13. Independent Adjustable Speeds

RUN/JOG switch

Using a RUN/JOG switch is recommended in applications where quick and frequent jogging is required. Use a single pole, two position switch for the RUN/JOG switch, and a single pole, normally closed, momentary operated pushbutton for the JOG pushbutton.

RUN/JOG option #1

In the first wiring option, connect the RUN/JOG switch and JOG pushbutton to the inhibit plug as shown in Figure 14. The motor coasts or brakes to a stop when the RUN/JOG switch is set to JOG. Press the JOG pushbutton to jog the motor. Return the RUN/JOG switch to RUN for normal operation.

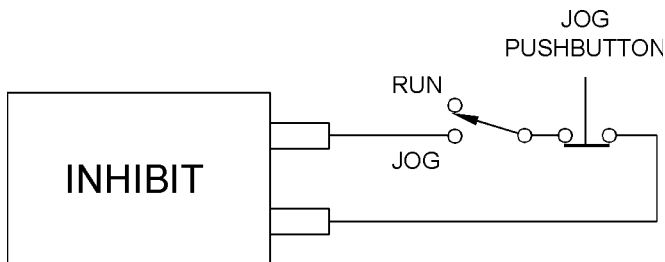

**Figure 14. RUN/JOG Option #1
(RUN/JOG Switch Connection to Inhibit Plug)**

RUN/JOG option #2

In the second wiring option, connect the RUN/JOG switch and the JOG pushbutton as shown in the Figure 15. When the RUN/JOG switch is set to JOG, the motor decelerates to minimum speed (minimum speed is determined by the MIN trimpot setting). Press the JOG pushbutton to jog the motor. Return the RUN/JOG switch to RUN for normal operation.

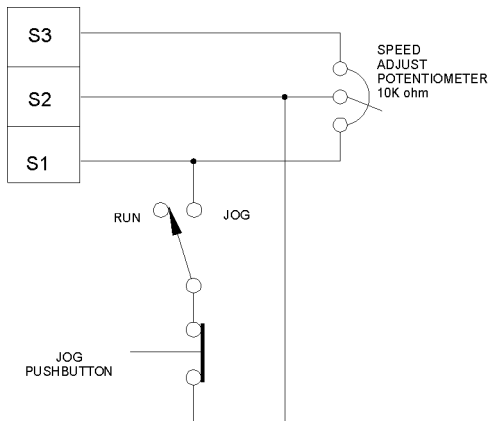

**Figure 15. RUN/JOG Option #2
(RUN/JOG Switch Connection to Speed Adjust Potentiometer)**

Leader-follower application

In this application, use a PCM4 to monitor the speed of the leader motor (Figure 16). The PCM4 isolates the leader motor from the follower drive, and outputs a voltage proportional to the leader motor armature voltage. The follower drive uses this voltage reference to set the speed of the follower motor. An optional ratio potentiometer may be used to scale the PCM4 output voltage.

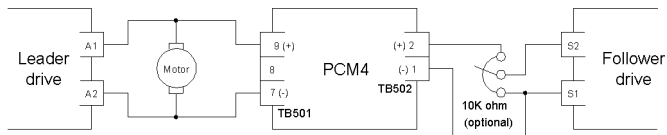

Figure 16. Leader-Follower Application

Single speed potentiometer control of multiple drives

Multiple drives can be controlled with a single speed adjust potentiometer using a PCM4 at the input of each drive to provide isolation (Figure 17). Optional ratio potentiometers can be used to scale the PCM4 output voltage, allowing independent control of each drive.

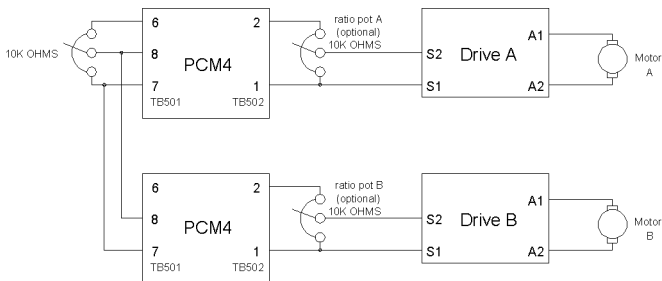

Figure 17. Single Speed Potentiometer Control of Multiple Drives

Troubleshooting



Warning

Dangerous voltages exist on the drive when it is powered. When possible, disconnect the drive while troubleshooting. High voltages can cause serious or fatal injury.

Before troubleshooting

Perform the following steps before starting any procedure in this section:

- Disconnect AC line voltage from the drive.
- Check the drive closely for damaged components.
- Check that no conductive or other foreign material has become lodged on the printed circuit board.
- Verify that every connection is correct and in good condition.
- Verify that there are no short circuits or grounded connections.
- Check that the drive's rated armature outputs are consistent with the motor ratings.

For additional assistance, contact your local Minarik® distributor, or the factory direct:

(800) MINARIK (phone) or (800) 394-6334 (fax).

Diagnostic LEDs

All 2 quadrant NRG drives have three diagnostic LEDs:

Power

Lights whenever the AC line voltage is applied to the drive.

Motor Output

Lights whenever motor current flows in the direction of motor rotation.

Regen Output

Lights whenever motor current flows in the opposite direction of motor rotation.

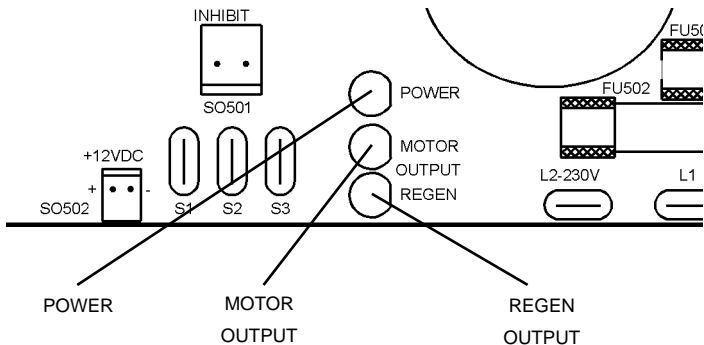

Figure 18. Diagnostic LED Location

Symptom	Possible Causes	Suggested Solutions
Line fuses blow	<ol style="list-style-type: none"> 1. Line fuses are the wrong size. 2. Motor cable or armature is shorted to ground. 3. Nuisance tripping caused by a combination of ambient conditions and high-current spikes (i.e. reversing). 	<ol style="list-style-type: none"> 1. Check that line fuses are properly sized for the motor being used. 2. Check motor cable and armature for shorts. 3. Add a blower to cool the drive components; increase MOTOR CURR. LIMIT and REGEN CURR. LIMIT settings.
Line fuse does not blow, but the motor does not run	<ol style="list-style-type: none"> 1. Speed adjust potentiometer or voltage input signal set to zero speed. 	<ol style="list-style-type: none"> 1. Increase the speed adjust potentiometer setting or voltage input signal.

Symptom	Possible Causes	Suggested Solutions
Line fuse does not blow, but the motor does not run (cont.)	<ol style="list-style-type: none">2. Speed adjust potentiometer or voltage input signal not connected to drive input properly; connections are open.3. Inhibit terminals are jumpered.4. S2 is shorted to S15. Drive is in current limit.6. Drive is not receiving AC line voltage.	<ol style="list-style-type: none">2. Check connections to input. Verify that connections are not open.3. Remove jumper from inhibit terminal.4. Remove short.5. Verify that motor is not jammed. Increase MOTOR CURR. LIMIT or REGEN CURR. LIMIT setting if they are set too low.6. Apply AC line voltage to L1 and L2.

Symptom	Possible Causes	Suggested Solutions
Line fuse does not blow, but the motor does not run (cont.)	7. Motor is not connected.	7. Connect motor to A1 and A2.
Motor runs too slow or too fast at set speed	1. Switches or jumpers are set incorrectly. 2. MIN and MAX are not calibrated.	1. Verify all switch and jumper settings. 2. Calibrate MIN and MAX trimpots.
Motor will not reach the desired speed	1. MAX setting is too low. 2. IR COMP setting is too low. 3. Motor is overloaded.	1. Increase MAX setting. 2. Increase the IR COMP setting. 3. Check motor load. Resize the motor if necessary.

Symptom	Possible Causes	Suggested Solutions
Motor pulsates or surges under load	<ol style="list-style-type: none"><li data-bbox="366 242 601 303">1. IR COMP is set too high.<li data-bbox="366 452 629 550">2. Motor “bouncing” in and out of torque limit.	<ol style="list-style-type: none"><li data-bbox="670 242 943 409">1. Adjust the IR COMP setting slightly CCW until the motor speed stabilizes.<li data-bbox="670 452 919 689">2. Make sure motor is not undersized for load; adjust MOTOR CURR. LIMIT and REGEN CURR. LIMIT trimpots.

Replacement Parts

Replacement parts are available from Minarik Corporation and its distributors for this drive series.

Model No.	Symbol	Description	Minarik P/N
NRG02–D240AC–2Q			
	BR1	Power Bridge	073–0010
	C503	470mF, 400 VDC Capacitor	011–0120
	FU501, 502	6A, 3AB Fuse	050–0016
	Q501–504	IRFP440 MOSFET	070–0077
	R501	0.1W, 5 W Resistor	032–0153
		10KW Potentiometer Kit	202–0039
NRG05–D240AC–2Q			
	BR1	Power Bridge	073–0010
	C503, 504	470mF, 400 VDC Capacitor	011–0120
	FU501, 502	10A, 3AB Fuse	050–0024
	Q501, 502	INXFH26N50 MOSFET	070–0079
	Q503	IRFP460 MOSFET	070–0066
	Q504	IRFP440 MOSFET	070–0077
	R501	0.01W, 5 W Resistor	032–0129
		10KW Potentiometer Kit	202–0039
NRG10–115AC–2Q			
	BR1	Power Bridge	073–0010
	C503, 504	1000mF, 200 VDC Capacitor	011–0096
	FU501	20A, 3AB Fuse	050–0019
	Q501–503	300 V, 35 A MOSFET	070–0105
	Q504	IRFP440 MOSFET	070–0077
	R501	0.01W, 5 W Resistor	032–0129
		10KW Potentiometer Kit	202–0039

Potentiometer Kit Contents (202-0039)

11 ea NON/INSU FEMALE TAB 1/4IN	163-0028
1 ea 10K OHM, 5W, 5% TOL.	120-0009
1 ea 3/8-32 X 1/2 NUT	151-0007
1 ea 3/8IN INT TOOTH LOCK WASHER	152-0007
1 ea POT INSULATING WASHER	156-0022

FUSE KIT CONTENTS**3–8A Fuse Kit (050–0069)**

2 ea 3 AMP 3AG FAST-ACTING FUSE	050-0021
2 ea 5 AMP 3AG FAST-ACTING FUSE	050-0022
2 ea 8 AMP 3AG FAST-ACTING FUSE	050-0059
1 ea 1/2A (.500) PICO FUSE	050-0074

5–20A Fuse Kit (050–0073)

2 ea 5 AMP 3AG FAST-ACTING FUSE	050-0022
2 ea 8 AMP 3AG FAST-ACTING FUSE	050-0059
2 ea 10 AMP 3AB NORMAL-BLO FUSE	050-0024
2 ea 15 AMP 3AB NORMAL-BLO FUSE	050-0018
2 ea 20 AMP 3AB NORMAL-BLO FUSE	050-0019
1 ea 1/2A (.500) PICO FUSE	050-0074

Inhibit Plugs

Inhibit Plug with 18 in. (46 cm) wires	201-0024
Inhibit Plug with 36 in. (91 cm) wires	201-0079

Notes

Notes

Unconditional Warranty

A. Warranty

Minarik Corporation (referred to as "the Corporation") warrants that its products will be free from defects in workmanship and material for twelve (12) months or 3,000 hours, whichever comes first, from date of manufacture thereof. Within this warranty period, the Corporation will repair or replace, at its sole discretion, such products that are returned to Minarik Corporation, 901 East Thompson Avenue, Glendale, CA 91201-2011 USA.

This warranty applies only to standard catalog products, and does not apply to specials. Any returns for special controls will be evaluated on a case-by-case basis. The Corporation is not responsible for removal, installation, or any other incidental expenses incurred in shipping the product to and from the repair point.

B. Disclaimer

The provisions of Paragraph A are the Corporation's sole obligation and exclude all other warranties of merchantability for use, express or implied. The Corporation further disclaims any responsibility whatsoever to the customer or to any other person for injury to the person or damage or loss of property of value caused by any product that has been subject to misuse, negligence, or accident, or misapplied or modified by unauthorized persons or improperly installed.

C. Limitations of Liability

In the event of any claim for breach of any of the Corporation's obligations, whether express or implied, and particularly of any other claim or breach of warranty contained in Paragraph A, or of any other warranties, express or implied, or claim of liability that might, despite Paragraph B, be decided against the Corporation by lawful authority, the Corporation shall under no circumstances be liable for any consequential damages, losses, or expense arising in connection with the use of, or inability to use, the Corporation's product for any purpose whatsoever.

An adjustment made under warranty does not void the warranty, nor does it imply an extension of the original 12-month warranty period. Products serviced and/or parts replaced on a no-charge basis during the warranty period carry the unexpired portion of the original warranty only.

If for any reason any of the foregoing provisions shall be ineffective, the Corporation's liability for damages arising out of its manufacture or sale of equipment, or use thereof, whether such liability is based on warranty, contract, negligence, strict liability in tort, or otherwise, shall not in any event exceed the full purchase price of such equipment.

Any action against the Corporation based upon any liability or obligation arising hereunder or under any law applicable to the sale of equipment or the use thereof, must be commenced within one year after the cause of such action arises.

Other drives from Minarik Corporation:



MMRGD Series



DLC500

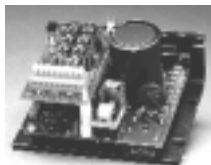

NRGD Series

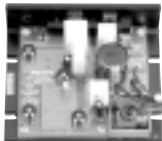
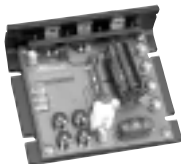

XP Series
(AC or DC Input)



901 East Thompson Avenue
Glendale, California 91201-2011

Tel: (800) MINARIK

Fax: (800) 394-6334

www.minarikcorp.com

Document Number 250-0246, Revision 2

Printed in the U.S.A – 5/01

\$12.00 North America, \$13.00 Outside North America