



Document No. : MD-QO-04-113

Date : 2009/09/10

Version : 1.0

**MD-955TC**  
**3 Piece High Purity Ball Valves,**  
**Tube Bore, Tri-Clamp**  
**USER MANUAL**



**Modentic Industrial Corporation**

14F-1, No.57 Taya Rd., Taichung, Taiwan, R.O.C.

Email: [modentic@ms9.hinet.net](mailto:modentic@ms9.hinet.net)

<http://www.modentic.com.tw>

## **WARRANTY**

Modentic warrants its products against defects in manufacturing if the products are used for the purposes for which they are manufactured and sold. This warranty shall expire one year from date of shipments.

- 1. To use for company in Europe who will place the product on the market, please amend which necessary.*
- 2. Modentic reserves the right to change any details without prior notice.*

# Contents

1. General Precautions
2. General Description of Product
3. Pressure-Temperature Ratings
4. Delivery Condition and Storage
5. Installation and Operation
6. Put into service
7. Dangers of inappropriate use
8. Maintenance
9. Corrosion Data
10. Use in potential explosive atmosphere areas
11. Marking

Importer, Agent or Distributor responsible for servicing

--

## 1. General Precautions

### a. Operation:

Ball valve is a kind of isolating valve used in a pipe line system, which intended for use only in the closed or fully open position. In the open position, it allows the flow passes through.

### b. Material Selection:

The possibility of material deterioration in service and the need for periodic inspections is depended on the contained fluid. Carbide phase conversions to graphite, oxidation of ferrite materials will decrease in ductility of carbon steels at low temperature are among those items. However information about corrosion data is provided together with this user manual, the user is requested to take attention or consideration to determine the suitability of material in their application.

### c. Pressure-Temperature rating:

The Pressure-Temperature rating is considered for static pressure. Please refer to P & T rating section 3 for actual application. The allowable temperature is between -20°C and 180°C. Do not exceed the temperature range to avoid danger.

### d. Fluid thermal expansion:

It is possible, when the ball valve is in closed condition, the sealed cavity within the valve body to be filled with liquid. If this liquid is not released, by partially opening the valve or some other means, and it is subject to a temperature increase, excessive pressure sufficient to cause pressure boundary failure can be occurred. However our products have pressure self-relief seat to prevent pressure built up, user is recommended to prevent that the pressure in the valve will not exceed that allowed pressure, by means of piping design, installation, or operation procedure.

### e. Electro Static effect:

The ball valves are designed with electrical continuity for ball-stem-body to prevent electro static discharge. The user is

responsible for ensuring the earthing of the pipeline system.

### f. Fire safe condition:

Fire safe certificates are only available upon request.

### g. Liquids with high fluid velocity:

The ball valves might be operated frequently with very high velocity liquids, a check shall be made with the valve distributor or manufacturer for appropriate advice to minimize the possibility of seat deformation, especially when they are highly pressurized on high-temperature line.

### h. Throttling service:

Ball valves are generally not recommended for throttling service, where both the fluid flow and the leading edge of the ball can damage or deform the resilient ball seats causing leakage. High fluid velocity or the presence of solid particles in suspension will further reduce seat life in throttling applications.

### i. Do not open the bonnet or cap when bearing pressure. Valve is not equipped with pressure access device. User should check it by other method through its piping system.

### j. Do not touch the surface of valve at high temperature condition.

### k. Not allowed for unstable fluid, otherwise specified with PED category III in Declaration of conformity or/and in this user manual.

### l. Lock design on the handle to avoid the valve by un-intended operated by un-authorized person.

### m. Use in potential explosive atmosphere safely, see section 10 for detail.

## 2. General description of the product

### a. Technical specification

Model:	3PC				
Port:	Tube Bore				
End connection:	T-CLAMP END				
Service fluid	Dangerous or non-dangerous gas or liquid				
Service temp.	-20°C to 180°C				
Nominal Size NPS	1/2"	3/4"	1"	1½"	2"
Nominal Size DN	15	20	25	40	50
Nominal pressure psi	000	2000	000	000	2000
Shell Material	SS316L				

Note 1: User shall consider the material's anti-corrosion feature of components which directly contact with the fluid. The corrosion data information is available in this user manual.

### b. Safety features

- Appropriate shell strength
- Anti-blow out stem design
- Anti-static design
- Pressure release hole at ball
- Pressure release channel at ball seat

### e. Equipment category according to PED Directive (97/23/EC)

Nominal Pressure	S.E.P	Category II
2000psi	DN 15 DN 20 DN 25	DN40 DN50

### c. Dimensions and Parts list

See the following drawing for the detailed external dimensions of each nominal size, the components list and materials available. User shall consider the material's anti-corrosion feature of seals and packing which directly contact with the fluid. The corrosion data information is available in this user manual.

### d. Equipment category according to ATEX

Directive (94/9/EC)

Designed and constructed to good engineering practice and the ignition hazard assessment ensure that the equipment does not contain any effective ignition sources in normal operation and during expected malfunctions. Therefore we classified as **Group II, Category 2** equipment. The Type of ignition protection is 'c', constructional safety according to EN 13463-5:2003.

f. Dimensions/ Parts List

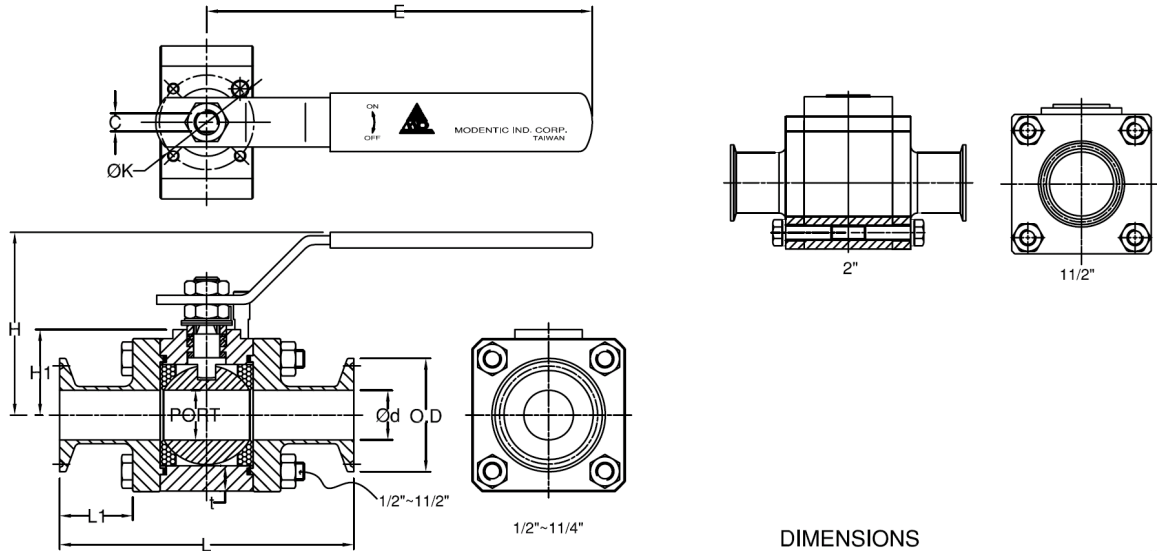

**DIMENSIONS**

SIZE	PORT	L	L1	E	H	H4	C	ØK	O.D	Ød	t min	unit:mm
DN15	1/2"	9.5	102.4	22.7	132.8	69.3	31.0	6.5	36.0	25.0	9.4	4.1
DN20	3/4"	15.9	112.6	26.8	132.8	73.8	35.0	6.5	36.0	25.0	15.75	5.1
DN25	1"	22.2	130.7	32.5	171.8	81.9	38.0	8.0	42.0	50.4	22.10	6.4
DN40	1-1/2"	34.9	150.1	32.4	204.2	97.5	49.5	9.7	50.0	50.4	34.8	6.6
DN50	2"	47.6	171.4	35.2	204.2	114.9	71.0	9.7	50.0	63.9	47.5	8.5

**MATERIALS LIST**

NO.	PART NAME	MATERIAL
1	BODY	SS316L
4	BALL	SS316L
5	STEM	SS316L
9	END CAP	SS316L
11	BODY SEAL	TFM-1600
12	SEAT	TFM-1600
13	THRUST WASHER	TFM-1600
14	STEM PACKING	TFM-1600
15	GLAND BUSH	SS304
19	HANDLE	SS304
21	HANDLE COVER	PLASTIC
22	STEM HALF NUT	SS304
29	BELLEVILLE WASHER	SS304
30	TAB WASHER	SS304
32	PACKING FOLLOWER	TFM-1600
33	LEVER STOP	SS304
35	BODY BOLT	SS304
36	BOLT WASHER	SS304
37	BOLT NUT	SS304

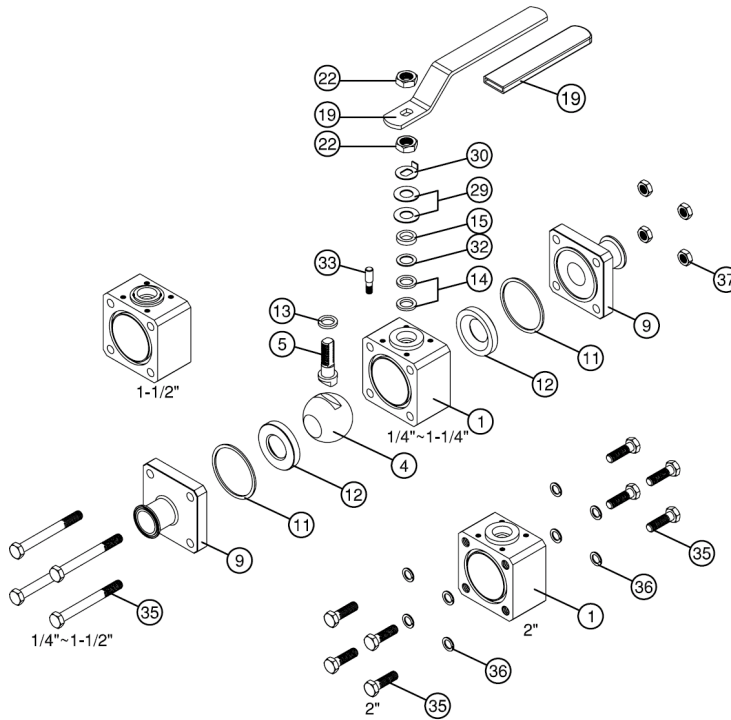

### 3. Pressure-Temperature Ratings

The pressure-temperature rating of ball valves are determined, not only by valve shell materials, but also by sealing materials used for ball seats, stem packing, and body seal. Sealing materials may be high molecule, elasticity and hardness, however, the choice is limited by the characteristics of the service fluid, temperature, pressure, velocity of fluid, frequency of valves operation and sizes of ball valves etc. User shall notice the maximum temperature labeled on the name plate. Followings are the general rating charts for non-shock fluid service for floating ball valves by nominal pressure.

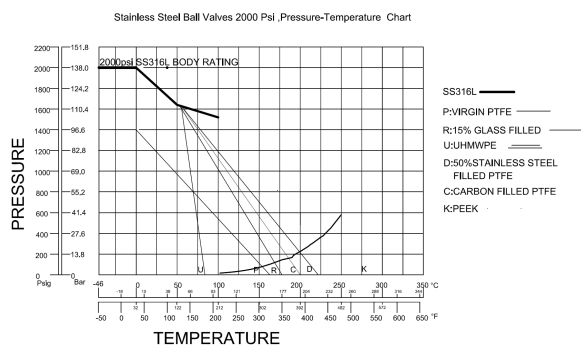

Temp. (°C)	2000psi Bar
-20 to 0	124.1
0 to 50	119.8
50 to 100	103.4
100 to 150	93.7
150 to 200	86.1

### 4. Delivery Condition and Storage

Valves stay in the open condition during the transportation. Valves must store in an indoor warehouse to avoid dusts and other foreign object. Do not take off the dust cover except ready to install immediately.

### 5. Installation and Operation

#### 5.1 Cleaning

Even the valves was transported under a clean environment, operator must check is there any foreign body or dusts inside the bore. If yes, clean it before installation. Operator clean the valves by water, compression air, or steam (automation valve shall be cleaned only with water or steam, the compression air is not allowed.)

### 5.2 Valve Installation

(Install to the pipeline system)

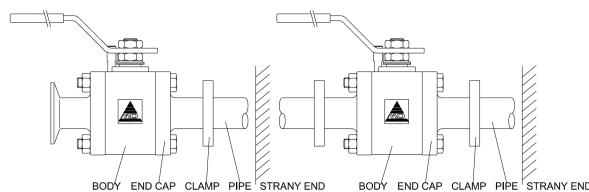

#### a. Direction

Ball valve does not restrict the flow direction. Just consider the natural sequence to do opening and close the valve.

#### b. Position

Ball valve can be installed in any position, but the operator shall consider the load of the pipe line system not to apply at the connection area. It will cause deformation and leakage.

#### c. Connecting to pipeline

Select the correct specification of pipeline.

Tight the ball valve to the pipeline adequately

### 5.3 Actuator installation

The ball valves are designed with ISO 5211 actuator attachment. Following is the mounting flange sizes.

The sizes of actuator and setting of the input power or pressure of actuator are depended on the operation torque. The following table lists the maximum torque values of each flange type. User is recommended to refer to the instruction from actuator's supplier. Overload torque applied by the actuator may transfer the un-intended load to ball valve itself or to the piping joints. Setting of the input power or pressure of the actuator is better not to exceed 1.5 times the Maximum torque of the valve.

Nominal Size	Mounting Pad flange type	Max. torque (Nm)
DN 15	F03	32
DN 20	F03	32
DN 25	F04	63
DN 40	F05	125
DN 50	F05	125

## 5.4 Operation

- a. For manual operation, shift the handle in counter-clockwise direction for opening and clockwise for close.
- b. If the handle is in parallel position with the flow direction, the valve is open. If the handle is in right angle position with the flow direction, the valve is close.
- c. When installing actuator, the user should ensure the position of the valve whether open or close. The rectangular shape of the stem top or the direction mark at the stem top is in parallel with the flow direction means the valve is opened.

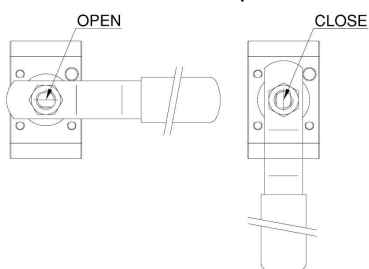

## 6. Put into service

- a. After install to the pipeline, it is necessary to check the function of the product. Thus, operate the valve about 3 times to ensure the function.
- b. Systems hydrostatic test  
Before delivery, valves are tested 1.5 times the allowable working pressure at ambient temperature in open position. After installation, the pipe line system may subject to system tests, as condition not to exceed the maximum working pressure.
- c. After pressure testing, user shall operate the valve again about 3 times to ensure the function.

## 7. Dangers of inappropriate use

- a. Never uses the product exceed its allowed condition, such as pressure, temperature and fluid.
- b. If the product has any inappropriate use, the product was damage however there are no signals occurs immediately. User shall change the product to avoid danger in the future.

## 8. Maintenance

- a. Maintenance frequency  
The maintenance frequency is determined upon the application. User shall consider the time interval depend on the kinds of fluid, flow velocity, operation frequency, high-pressure effect and high-temperature effect etc.
- b. Adjustment of the Gland  
Tighten the gland nut about  $\frac{1}{4}$  turn periodically to compensate for the wear caused by movement between stem and stem packing.
- c. Disassembly  
(NOTE If complete disassembly is necessary, replacement of all seats and seals is recommended.)
  - (1) To dismantle the valve must follow the procedure below.
  - (2) It doesn't matter where the position of valve located is; usually it contained the seal up fluid, so operator must be very carefully when moving the valve on the pipe. It must open the ball a little and let the fluid come out slowly, it also need to watch out the poisonous and inflammability objects if there is any.
  - (3) It must turn the ball in the close position before dismantle the valve. The ball cannot be taken out from valve body if the ball is in the open or semi-open position. The right position for store the valve is put the flange end on the ground. If it is a valve with the hand wheel, than it must dismantle the hand wheel from the valve first than put the valve flange end on the ground. This procedure is protecting the surface of the ball.
  - (4) To dismantle the valve body and end cap, release retainer with a special tool. It must be careful to dismantle the ball to avoid the seat retainer fall down from end cap.
  - (5) To lift the ball by hoist, it must make the protection on corner to avoid the ball damaged by metal contacted.

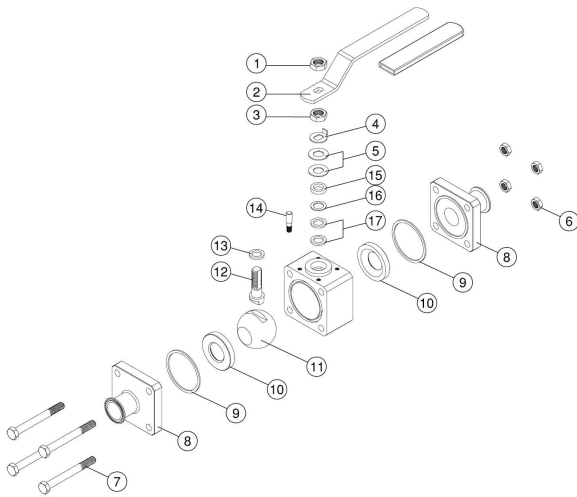

d. Parts inspection, maintenance, and replacement:

- (1) Check the surface of ball if it is scraped use the PT for inspection if necessary. If there is any damage on the surface, then find out the root cause such as the dirt fluid...etc. avoid the damage factors as far as possible as we can .
- (2) The damage of the ball surface, to gauge if it is locate on the contacting area of ball and ball seat. If it is the case, then the ball must take a fine milling. If it cause a heavy damaged, then it must welded and re-machined. If it cannot be repaired then change a new ball.
- (3) If the scraped area is not at the location described in the item (2) above, then it must re-fine milling the damage area again. Otherwise, the ball will damage the soft seat during the open and close operation or it will dig out the ball seat and cause a heavy damage to ball and seat.
- (4) Check the thickness of valve body and cap. As defined in section 1. the body and cap material may wear be cause of the status of fluid. User should decide the frequency for checking thickness.
- (5) To inspect the surface of soft seat, if there is it any scrap mark, concave, dust (including weld dregs, iron bit, sands...etc.), abrasion, abnormal press scrape, and a tiny scrap. Usually, the scrape mark and damage by dust will occur in the same time with ball damage. It is the root cause for leakage. If the leakage occurs before the repairing, then this is suggest to change a new soft seat (PTFE or RTFE). The mark from press or fine scrap

happen in an abnormal operation pressure. It must be reconsidered to choice a right valve.

- (6) To check the worm gear if it can be operated correctly, the operated correctly means people can use one finger to turn the wheel. when the torque higher then 25KG-M, if must open the gear- box and check the connection of the tooth of gear. To check has there is any grease, spoiled grease, water, oxidation or dust in the box.
- (7) Worm gear operator has a switch of open/close indicator get back to the original location after dismantle or assembly. It must do the pressure inspection before install onto pipe line, otherwise, it will become very difficult to do adjustment on the pipe line. The stem packing must be replaced by new parts after dismantle the valve. Its material has PTFE, Graphite and Carbon Fiber. The material of new packing must be the same as the old one. To tight the gland nut, it must pass the 1.5 times water pressure test without leakage. Do not make the gland nut too tight to avoid the higher torque.
- (8) To do the final inspection for a valve, 10 times of open and close operating must be done to ensure all the parts are assembled correctly. To ensure the torque is in a same value during the open/close operation. If the torque is not the same in operation, then there may has some parts in an correct position or interference. please dismantle and re-assembly. Otherwise, the valve will get damaged easily when working on pipeline under higher pressure

e. Assembly

For assembly process, it takes the opposite way of dismantle process. The must in the close position during assembling the body and end cap, the stopper must be located at the right place; otherwise, the open and close operation will be opposite.



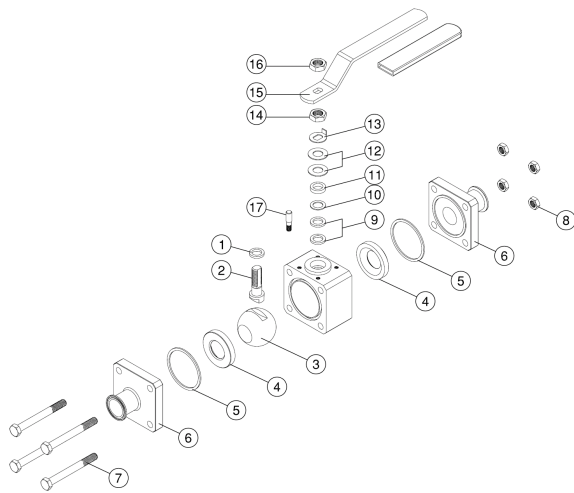

## 9. Corrosion Data

CF8M, 1.4408, SS316 Stainless steel is suitable for the general

Application of corrosion, but below conditions shall be concerned:

- HCL in humid or high temperature is more corrosive, wet HCL is more corrosive than dry HCL under 700°F, while the corrosive, wet HCL and dry HCL are almost the same above 700°F. the max. tolerance for dry HCL and HCl is 320°C
- Hydrofluoric acid corrosion easy cause corrosion.
- Phosphoric acid under 65°C is applicable in any thickness. And so is the boiling Phosphoric acid in 40%
- H<sub>2</sub>SO<sub>4</sub> in normal temperature the thickness under 20% or above 85% are applicable, but the thickness between 20% and 85% are not. Under 50°C the thickness must be under 10%, when reach boiling point the thickness should be under 1%.
- HCl under 2% in low temperature.
- Used in seawater minimum content should be more than 2.75%

## 10. Use in potential explosive atmosphere areas

- Maximum surface temperature  
It is depends on the heated fluid inside the valve. The limitation of the application temperature is marked on the label. There is no additional temperature raise cause by normal operation and expected malfunction.
- Electro static charges  
The only non-conductive part of the

equipment is the plastic handle grip. The surface resistance of the material does not exceed 1GΩ at (23 ± 2) °C and (50 ± 5)% relative humidity. The equipment also designed and constructed with an electrical continuity design between ball, stem and body. Any occurrence of efficient electro static charge will be earthed through the pipe line earthing.

- Containing light metals  
Materials used in the construction of external parts do not contain light metals more than 7.5% of magnesium.
- Equipment was tested in factory according to high pressure leakage test before delivery. It will not release flammable gases to explosive atmosphere outside the equipment.
- The internal parts, such as seals and packing can be adversely affected by some solvents. List of solvents which are known to be compatible with the seal and packing material are provided in the corrosion data information.
- The equipment also conforms to Pressure Equipment Directive (97/23/EC), The mechanical strength of the structure can withstand the hazard cause by internal pressure.

## 11. Marking

Mfg logo: MD

Mfg location: TAICHUNG, Taiwan

Mfg year: 2009

CE mark: CE for DN 25 and smaller

CE<sub>0035</sub> for DN 32 and larger

Max. working pressure:

For 2000psi: 124.1bar at -20°C,

86.1bar at 180°C



ATEX mark

**II2DGc**: Group II, category 2 equipment,  
Dust & Gas application,  
Constructional safety according to  
EN 13463-5:2003.

T.F ref. No. ATEX-TF-0701: Technical file

reference number provided by ATEX certification body.

Other identification such as **DN** (size in mm),  
**Shell Material (1.4408 or 1.4308 or 1.0619)**, **PN** (bar), **Heat number** are marked on the shell respectively.

1. CE MARK



ENLARGE OR REDUCE ACCORDING TO THE ABOVE SKETCH.  
 BUT THE MIN HEIGHT IS 5 mm  
 0035 IS THE ID OF TUV

2. COMPANY LOGO

MUST COME WITH COMPANY LOGO OR CUSTOMER'S LOGO APPOINTED  
 BUT MUST ILLUSTRATE ON THE CERTIFICATE

3. YEAR OF MANUFACTURE: SHOW ON PROPER PLACE

4. EXTRA MARKING REQUIRED BY CUSTOMER.

5. SYMBOL, FOLLOWED BY EQUIPMENT GROUP AND CATEGORY

	T1 (450°C)	T2 (300°C)	T3 (200°C)	T4 (135°C)	T5 (100°C)	T6 (85°C)
I	Methane					
IIA	Acetone Ethane Ammonia Benzol Acetic acid Methanol Propane Toluene	Ethyl alcohol n-Butane n-Butyl alcohol Dichloroethane	Benzene Diesel fuel n-Hexane Fuel oil	Acetaldehyde		
IIIB	Town gas		Ethylene Ethylene oxide	Ethyl ether		
IIIC	Hydrogen	Acetylene	Carbon disulphide			

