



**User's Manual**

**2801450**

Version 1.1 9/11/2006

## Copyright

Copyright 2006, all rights reserved. This document is copyrighted and all rights are reserved. The information in this document is subject to change without prior notice to make improvements to the products.

This document contains proprietary information and protected by copyright. No part of this document may be reproduced, copied, or translated in any form or any means without prior written permission of the manufacturer.

All trademarks and/or registered trademarks contains in this document are property of their respective owners.

## Disclaimer

The company shall not be liable for any incidental or consequential damages resulting from the performance or use of this product.

The company does not issue a warranty of any kind, express or implied, including without limitation implied warranties of merchantability or fitness for a particular purpose. The company has the right to revise the manual or include changes in the specifications of the product described within it at any time without notice and without obligation to notify any person of such revision or changes.

## Trademark

All trademarks are the property of their respective holders.

## Packing List:

Please check the package content before you starting using the board.

### Hardware:

2801450A or 2801450B Mini ITX Motherboard x 1

### Cable Kit:

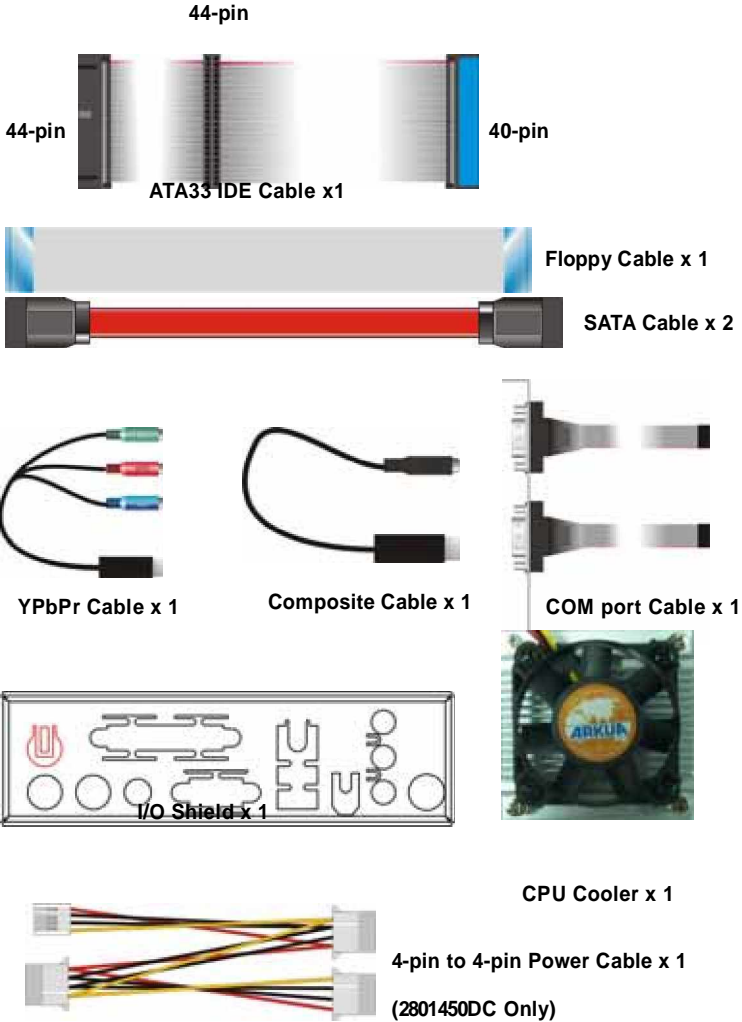

### Printed Matters:

User's Manual x 1

Driver CD x 1

---

## Index

<b>Chapter 1 &lt;Introduction&gt;</b> .....	<b>7</b>
1.1 <Product Overview>.....	7
1.2 <Product Specification> .....	8
1.3 <Mechanical Drawing>.....	10
1.4 <Block Diagram>.....	11
<b>Chapter 2 &lt;Hardware Setup&gt;</b> .....	<b>13</b>
2.1 <Connector Location>.....	13
2.2 <Jumper Location & Reference> .....	14
2.3 <Connector Reference> .....	15
2.3.1 <Internal Connectors> .....	15
2.3.2 <External Connectors>.....	15
2.4 <CPU and Memory Setup> .....	16
2.4.1 <CPU Setup> .....	16
2.4.2 <Memory Setup> .....	17
2.5 <CMOS Setup> .....	18
2.6 <Enhanced IDE Interface>.....	19
2.7 <Serial ATA Interface>.....	19
2.8 <Floppy Port>.....	20
2.9 <Ethernet Interface> .....	21
2.10 <Onboard Display Interface> .....	22
2.10.1 <Analog Display> .....	22
2.10.2 <Digital Display>.....	23
2.10.3 <HDTV Interface>.....	27
2.11 <Integrated Audio Interface> .....	28
2.12 <GPIO Interface> .....	30
2.13 <Power Supply> .....	31
2.13.1 <Power Input> .....	31
2.13.2 <Power Output> .....	32
2.14 <Switch and Indicator>.....	33

---

---

<b>Chapter 3 &lt;System Setup&gt;</b> .....	<b>34</b>
3.1 <Video Memory Setup> .....	34
<b>Chapter 4 &lt;BIOS Setup&gt;</b> .....	<b>36</b>
<b>Appendix A &lt;I/O Port Pin Assignment&gt;</b> .....	<b>38</b>
A.1 <IDE Port> .....	38
A.2 <Serial ATA Port>.....	39
A.3 <Floppy Port> .....	39
A.4 <IrDA Port> .....	39
A.5 <Serial Port>.....	40
A.6 <VGA Port>.....	41
A.7 <LAN Port> .....	41
A.3 < USB Interface > .....	41
<b>Appendix B &lt;Flash BIOS&gt;</b> .....	<b>42</b>
B.1 <Flash Tool> .....	42
B.2 <Flash BIOS Procedure> .....	42
<b>Appendix C &lt;System Resources&gt;</b> .....	<b>43</b>
<b>Appendix D&lt;Programming Watchdog Timer&gt;</b> .....	<b>48</b>
<b>Appendix E&lt;How to setting RS422&amp;RS485&gt;</b> .....	<b>49</b>
<b>Contact Information</b> .....	<b>50</b>

(This Page is Left for Blank)

# Chapter 1 <Introduction>

## 1.1 <Product Overview>

**2801450** is the new generation of the Mini-ITX motherboard, with supporting Intel Core 2 Duo/ Core Duo/ Core Solo processors for 533/667MHz front side bus, Intel 945GM and ICH7-M chipset, integrated GMA950 graphics, DDR2 memory, REALTEK High Definition Audio, Serial ATA, PCI Express x1,x16 interface and one Intel 82537L Gigabit LAN .

### **Intel Yonah dual core Processor**

The board supports Intel Core Duo/Core Solo processors with 533/667MHz front side bus, 2MB L2 cache, to provide more powerful performance than before.

### **New features for Intel 945GM chipset**

The board integrates Intel 945GM and ICH7-M chipset, to provide new generation of the mobile solution, supports Intel GMA950 graphics, DDR2 400/533/667 memory, built-in high speed mass storage interface of serial ATA, High Definition Audio with 5.1 channels surrounding sound.

### **All in One multimedia solution**

Based on Intel 945GM and ICH7-M chipset, the board provides high performance onboard graphics, 18-bit Single/dual channel LVDS interface, HDTV and 5.1 channels High Definition Audio, to meet the very requirement of the multimedia application.

### **Flexible Extension Interface**

The board provides one PCI-Express x16 slots for graphics card, it also can support PCI-Express x1 for LAN card or other devices. The board also provides CompactFlash Type II slot and two mini-PCI slot.

## 1.2 <Product Specification>

### General Specification

Form Factor	Mini-ITX motherboard
CPU	Intel® Core 2 Duo/ Core Duo/ Core Solo processors Package type: FC-PGA478 L2 Cache: 2MB Front side bus: 533/667MHz
Memory	2 x 240-pin DDR2 400/533/667MHz SDRAM up to 3GB Up to 10.67GB/s of bandwidth with dual-channel interleaved mode <b>Dual-Channel technology</b> supported Unbuffered, none-ECC memory supported only
Chipset	Intel® 945GM (Northbridge) and ICH7-M (Southbridge)
BIOS	Phoenix-Award v6.00PG 4Mb PnP flash BIOS
Green Function	Power saving mode includes doze, standby and suspend modes. ACPI version 1.0 and APM version 1.2 compliant
Watchdog Timer	System reset programmable watchdog timer with 1 ~ 255 sec./min. of timeout value
Real Time Clock	Intel® ICH7-M built-in RTC with lithium battery
Enhanced IDE	UltraDMA33 IDE interface supports up to 2 ATAPI devices One 44-pin IDE port onboard One CompactFlash Type II socket on solder side
Serial ATA	Intel® ICH7-M integrates 2 Serial ATA interfaces(No RAID Function) Up to 150MB/s of transfer rate

### Multi-I/O Port

Chipset	Intel® ICH7-M with Winbond® W83627THG controller
Serial Port	1x RS232 Port, 1x RS232/422/485 Port
USB Port	Six Hi-Speed USB 2.0 ports with 480Mbps of transfer rate
Parallel Port	One D-sub 26pin LPT Port
Floppy Port	One slim type Floppy port
IrDA Port	One IrDA compliant Infrared interface supports SIR
K/B & Mouse	External PS/2 keyboard and mouse ports on rear I/O panel
GPIO	One 12-pin Digital I/O connector with 8-bit programmable I/O interface
Smart Fan	One CPU fan connectors for fan speed controllable

### VGA Display Interface

Chipset	Intel® 945GM GMCH (Graphic Memory Controller Hub)
Frame Buffer	Up to 224MB shared with system memory
Display Type	CRT, LCD monitor with analog display Onboard 18-bit single/dual channel LVDS interface TV-out
Connector	External DB15 female connector on rear I/O panel Onboard 40-in LVDS connector Onboard Mini Din 7-pin TV-out connector



### Ethernet Interface

Controller	Intel 82573L Gigabit Ethernet controller
Type	Triple speed 10/100/1000Base-T auto-switching Fast Ethernet Full duplex, IEEE802.3U compliant
Connector	One External RJ45 connector with LED on rear I/O panel

### Audio Interface

Chipset	Intel® ICH7M with Realtek® ALC880 High Definition Audio compliance
Interface	5.1 channels sound output
Connector	External Audio phone jack for Line-out, Line-in, MIC-in. Onboard audio connector with pin header (built-in amplifier for speaker out and MIC-in) Onboard CD-IN connector S/PDIF on rear I/O panel

### Expansive Interface

PCI-Express	One x16 PCI-Express slot ( <b>compatible with x1 slot</b> ) Up to 8GB/s of transfer bandwidth Power supply: +3.3V, +12V
PCI	Two Mini-PCI socket for <b>TYPE III A</b> (32-bit, 33MHz) Power supply: +3.3V, +5V
IEEE1394	One IEEE 1394 connector on rear I/O Panel

### Power and Environment

Power Requirement	Standard 24-pin ATX power supply (20-pin is compatible) (2801450) or 8~21V full range DC Input (2801450DC)
Input Range	8V ~ 21V full range DC Input (2801450DC)
Dimension	170 (L) x 170 (H) mm
Temperature	Operating within 0 ~ 60°C (32 ~ 140°F) Storage within -20 ~ 85°C (-4 ~ 185°F)

### Ordering Code

<b>2801450</b>	Onboard VGA,LVDS, one Intel Gigabit LAN, 6 x USB2.0,HDTV, 2 x Mini-PCI, HD Audio, SATA , 24-pin power connector(ATX PSU)
<b>2801450DC</b>	Onboard VGA,LVDS, one Intel Gigabit LAN, 6 x USB2.0,HDTV, 2 x Mini-PCI, HD Audio, SATA , 4-pin Power Din(DC adapter)
<b>3907644</b>	PCI-Express add-on card for 18/24bit dual channel LVDS Interface

The specifications may be different as the actual production.





(This Page is Left for Blank)

# Chapter 2 <Hardware Setup>

## 2.1 <Connector Location>

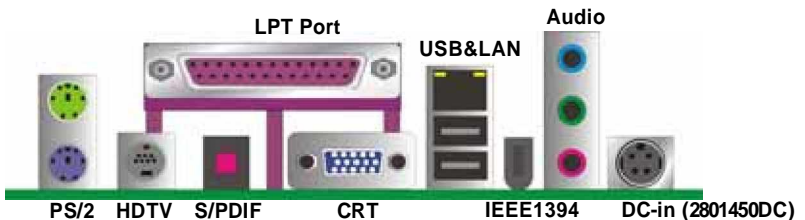
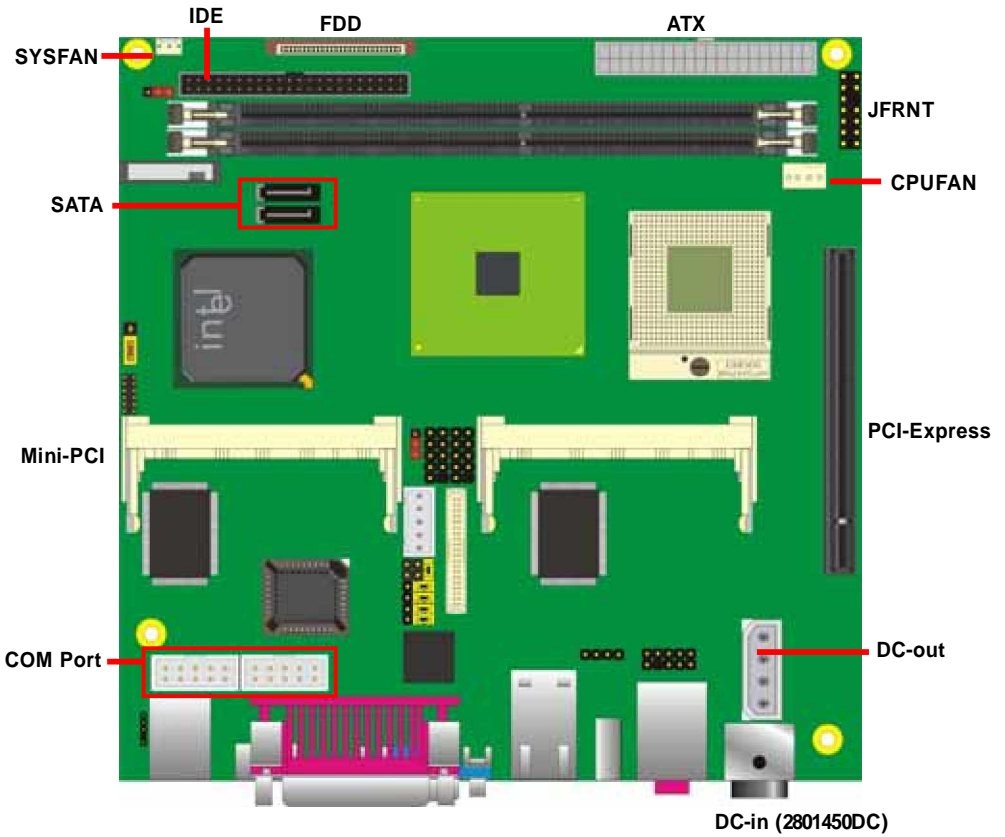

## 2.2 <Jumper Location & Reference>

Jumper	Function
JRTC	CMOS Operating/Clear Setting
JCFSEL	CF with IDE mode selection
JVLCD	Panel Voltage Setting

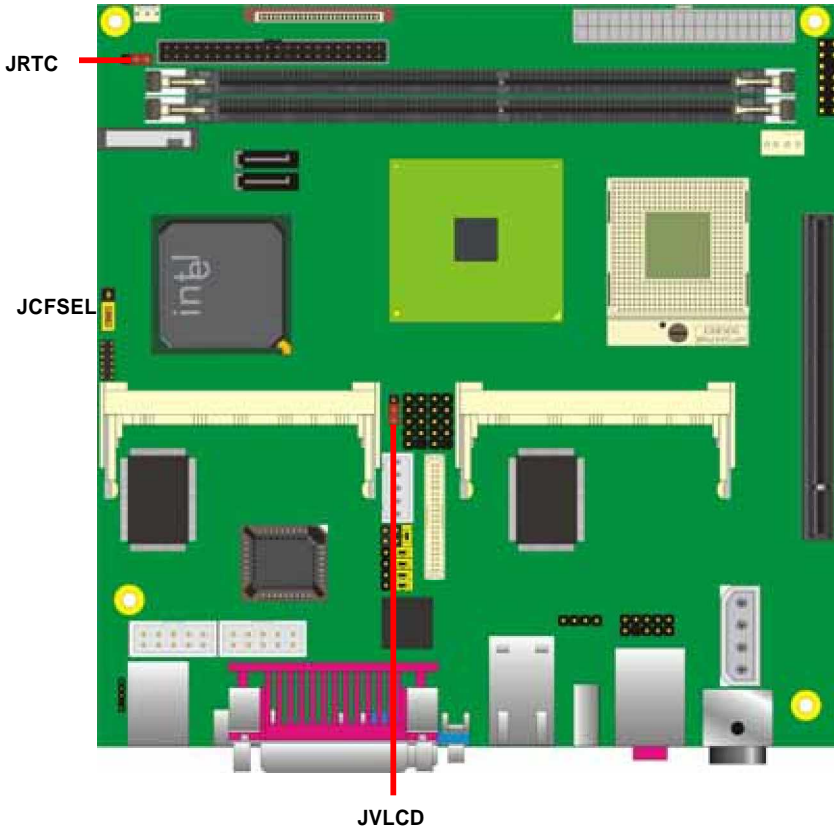

## 2.3 <Connector Reference>

### 2.3.1 <Internal Connectors>

Connector	Function	Remark
CPU	Socket479 for CPU	Standard
DDRIIA/B	Two 240 -pin DDR2 SDRAM DIMM slot	Standard
IDE	44-pin IDE connector	Standard
FDD	26-pin slim type floppy connector	Standard
S_ATA1/2	7-pin Serial ATA connector	Standard
PWRIN	24-pin power input connector (2801450 only)	Standard
CN_BPWR	4-pin power output connector	Standard
CN_AUDIO	5 x 2-pin audio connector	Standard
CDIN	4-pin CD-ROM audio input connector	Standard
CN_DIO	6 x 2-pin digital I/O connector	Standard
CN_USB	Two 5 x 2-pin USB connector	Standard
CPUFAN	4-pin CPU cooler fan connector	Standard
SYSFAN	3-pin system cooler fan connector	Standard
CN_LVDS	20 x 2-pin LVDS connector	Standard
CN_INV	5-pin LCD inverter connector	Standard
CN_IR	5-pin IrDA connector	Standard
JFRNT	14-pin front panel switch/indicator connector	Standard
MiniPCI	2 x Mini-PCI socket Type III	Standard
PCI_E16x	PCI Express 16x/1x slot	Standard
CF	CompactFlash Type II socket	Standard
COM1/2	Serial port connector	Standard

### 2.3.2 <External Connectors>

Connector	Function	Remark
DC_IN	DC 12V input connector(2801450DC only)	Standard
USB_RJ45	Dual USB and one RJ45 LAN connector	Standard
CRT	DB15 analog VGA connector	Standard
KB	PS/2 keyboard connector	Standard
MS	PS/2 mouse connector	Standard
AUDIO	Audio connectors	Standard
1394	IEEE1394 port	Standard
LPT	25-pin D-sub LPT port	Standard
HDTV	Mini Din 7-pin TV out	Standard
SPDIF	SPDIF digital audio output connector	Standard

## 2.4 <CPU and Memory Setup>

### 2.4.1 <CPU Setup>

The board comes with the socket479 for Intel Core Duo/Core Solo processors, it supports new generation of Intel Core Duo processors with 533/667MHz of front side bus and 2MB L2 cache. Please follow the instruction to install the CPU properly.

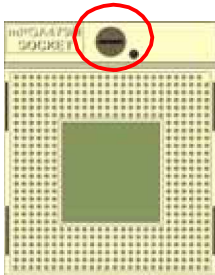

1. Use the flat-type screw drive to unlock the CPU socket



Unlock way

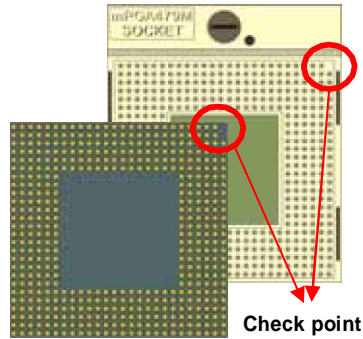

2. Follow the pin direction to install the processor on the socket



3. Lock the socket



### 2.4.2 <Memory Setup>

The board provides two 240-pin DDR2 DIMMs to support DDR 400/533/667 memory modules up to 3GB of capacity. Non-ECC, unbuffered memory is supported only. While applying two same modules, dual channel technology is enabled automatically for higher performance.

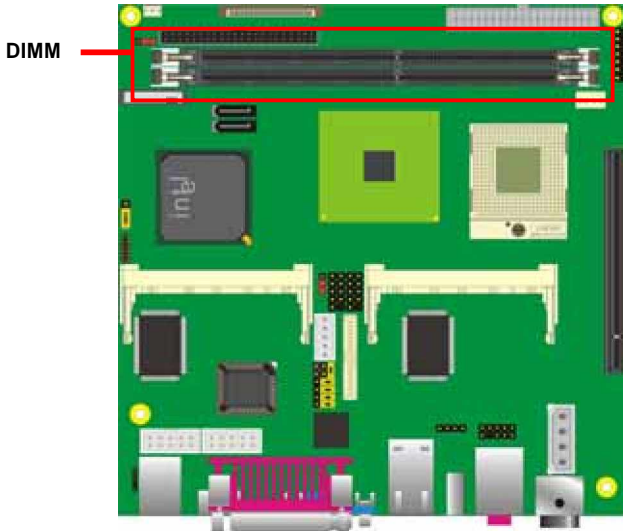

DDRIB/A

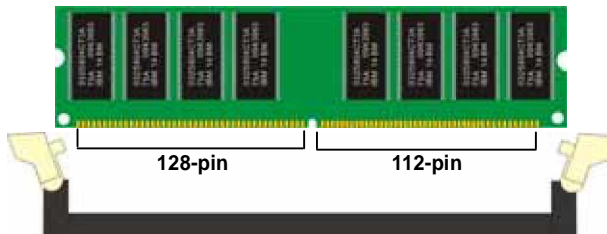

Please check the pin number to match the socket side well before installing memory module.

## 2.5 <CMOS Setup>

The board's data of CMOS can be setting in BIOS. If the board refuses to boot due to inappropriate CMOS settings, here is how to proceed to clear (reset) the CMOS to its default values.

**Jumper: JRTC**

**Type: Onboard 3-pin jumper**

JRTC	Mode
1-2	Clear CMOS
2-3	Normal Operation

Default setting

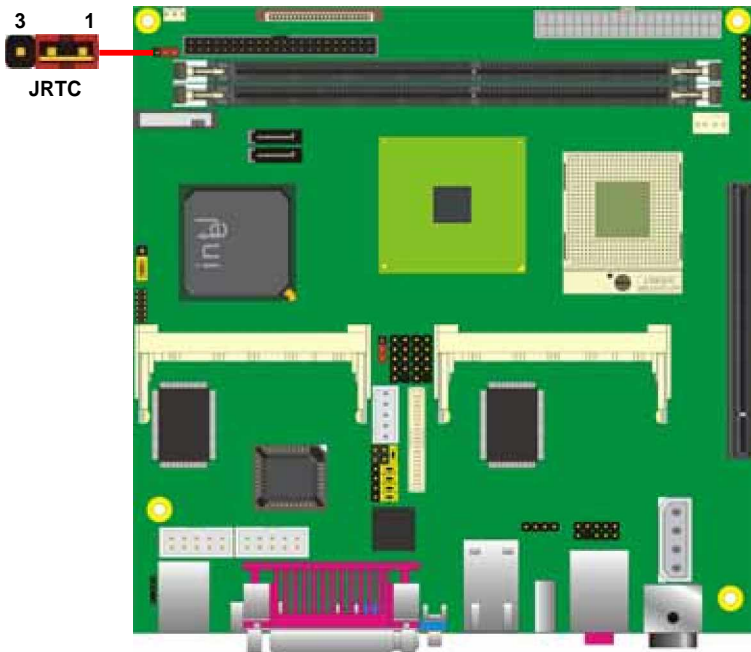

## 2.6 <Enhanced IDE Interface>

The board has one UltraDMA33 IDE interface to support up to 2 ATAPI devices, and one CompactFlash Type II socket on the solder side, with jumper **JCFSEL** for IDE master/slave mode selection.

Jumper: **JCFSEL**

Type: onboard 3-pin header

JCFSEL	Mode
1-2	Master
2-3	Slave

Default setting

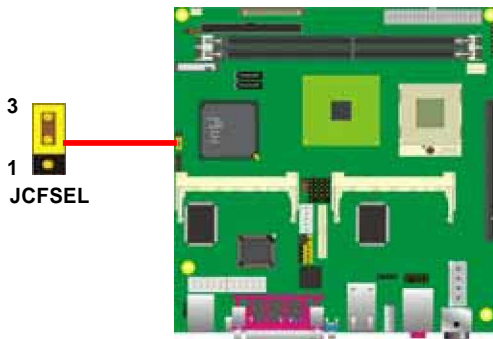

## 2.7 <Serial ATA Interface>

Based on Intel ICH7-M, the board provides two Serial ATA interfaces with up to 150MB/s of transfer rate.

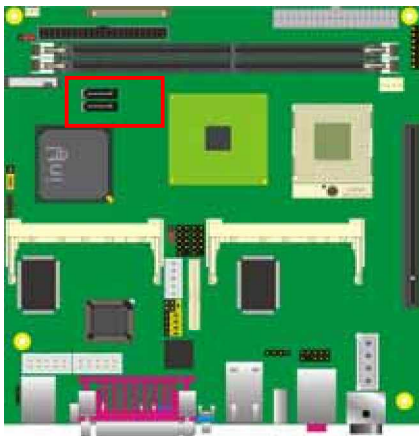

## 2.8 <Floppy Port>

The board provides one slim type floppy port.

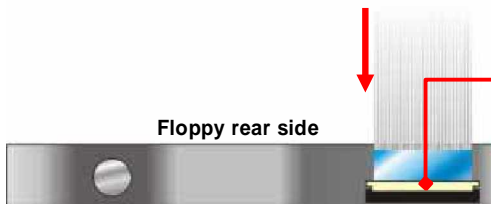
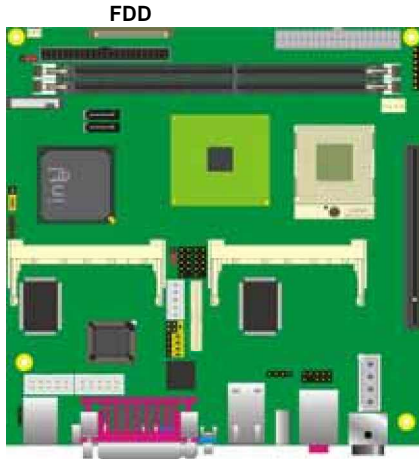

Floppy rear side

4. Lift up this plastic bar
5. Slot the cable in (Blue paste for outside)
6. Press back the plastic bar

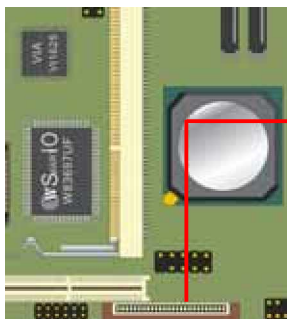

1. Lift up the brown plastic bar
2. Slot the cable in (Blue paste for brown bar side)
3. Press back the plastic bar

## 2.9 <Ethernet Interface>

The board integrates with one Intel 82573L PCI Express Gigabit Ethernet controllers, as the PCI Express 1x can speed up to 250MB/s of transfer rate instead of late PCI bus with 133MB/s of transfer rate. The Intel 82573L supports triple speed of 10/100/1000Base-T, with IEEE802.3 compliance and Wake-On-LAN supported.



## 2.10 <Onboard Display Interface>

Based on Intel 945GM chipset with built-in GMA (Graphic Media Accelerator) 950 graphics, the board provides one DB15 connector on rear external I/O port, and one 40-pin LVDS interface with 5-pin LCD backlight inverter connector. The board provides dual display function with clone mode and extended desktop mode for CRT and LCD. The board also provides DVO port on PCI Express slot to support DVI interface with add on card.

*Notice: When you install any PCI Express Graphic card, the onboard graphics would be disabled automatically.*

### 2.10.1 <Analog Display>

Please connect your CRT or LCD monitor with DB15 male connector to the onboard DB15 female connector on rear I/O port.



CRT

### 2.10.2 <Digital Display>

The board provides one 40-pin LVDS connector for 18-bit single/dual channel panels, supports up to 1600 x 1200 (UXGA) resolution, with one LCD backlight inverter connector and one jumper for panel voltage setting.

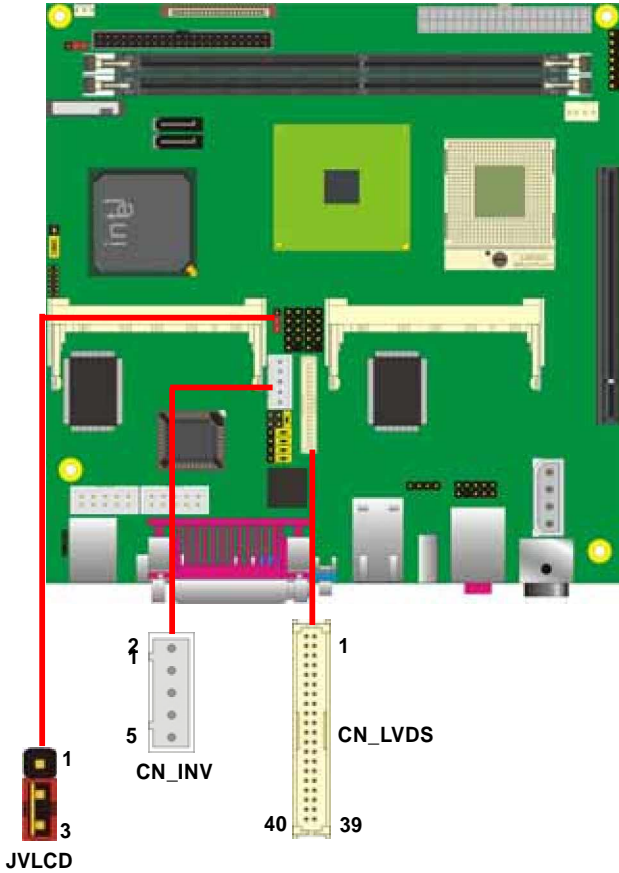

Connector: **CN\_INV**

Type: 5-pin LVDS Power Header

Pin	Description
1	+12V
2	GND
3	GND
4	GND
5	ENABKL

Connector: **JVLCD**

Type: 3-pin Power select Header

Pin	Description
1	VCC(5V)
2	LCDVCC
3	VCC3(3.3)

Connector: **CN\_LVDS**

Type: onboard 40-pin connector for LVDS connector

Connector model: **HIROSE DF13-40DP-1.25V**

Pin	Signal	Pin	Signal
2	LCDVCC	1	LCDVCC
4	GND	3	GND
6	ATX0-	5	BTX0-
8	ATX0+	7	BTX0+
10	GND	9	GND
12	ATX1-	11	BTX1-
14	ATX1+	13	BTX1+
16	GND	15	GND
18	ATX2-	17	BTX2-
20	ATX2+	19	BTX2+
22	GND	21	GND
24	ACLK-	23	BTX3-
26	ACLK+	25	BTX3+
28	GND	27	GND
30	ATX3-	29	BCLK-
32	ATX3+	31	BCLK+
34	GND	33	GND
36	DDCPCLK	35	N/C
38	DDCPDATA	37	N/C
40	N/C	39	N/C



To setup the LCD, you need the component below:

1. A panel with LVDS interfaces.
2. An inverter for panel's backlight power.
3. A LCD cable and an inverter cable.

For the cables, please follow the pin assignment of the connector to make a cable, because every panel has its own pin assignment, so we do not provide a standard cable; please find a local cable manufacture to make cables.

### LCD Installation Guide:

1. Preparing the **2801450**, LCD panel and the **backlight inverter**.

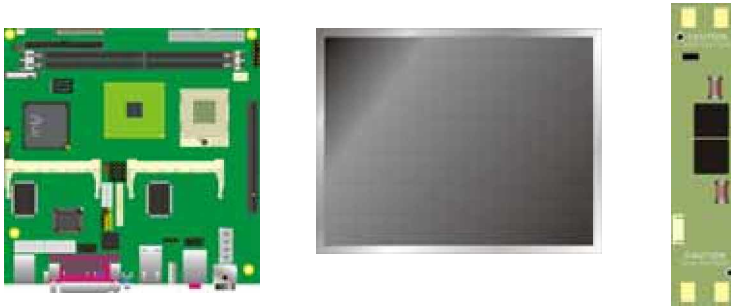

2. Please check the datasheet of the panel to see the voltage of the panel, and set the jumper **JVLCD** to +5V or +3.3V.
3. You would need a LVDS type cable.



4. To connect all of the devices well.

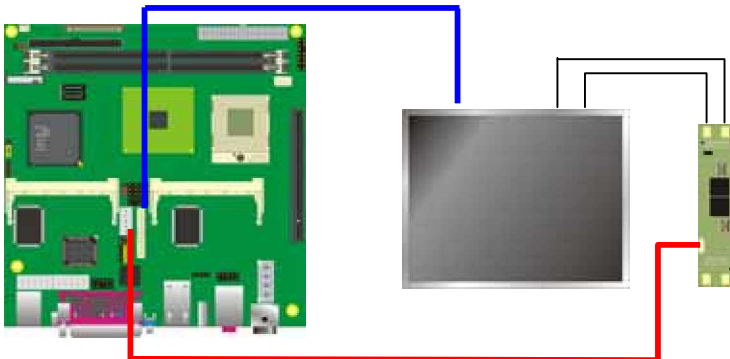

After setup the devices well, you need to select the LCD panel type in the BIOS.

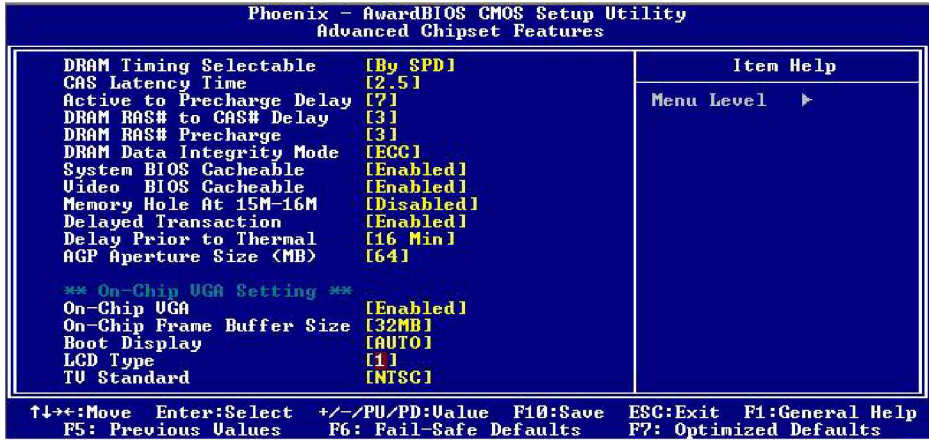

The panel type mapping is list below:

BIOS panel type selection form			
Single channel		Dual channel	
NO.	Output format	NO.	Output format
1	640 x 480	9	1024 x 768
2	800 x 600	10	1280 x 768
3	1024 x 768	11	1280 x 1024
4	1280 x 768	12	1366 x 768
5	1280 x 1024	13	1400 x 1050 @ 108Mhz
6	1366 x 768	14	1400 x 1050 @ 122Mhz
7	1280 x 800	15	1600 x 1200
8	1600 x 1200		

### 2.10.3 <HDTV Interface>

The board provides one Mini-Din 7pin support Composite, S-Video and Component .



## 2.11 <Integrated Audio Interface>

The board integrates onboard audio interface with REALTEK ALC880 codec, with Intel next generation of audio standard as High Definition Audio, it offers more sound and other advantages than former AC'97 audio compliance.

The main specifications of ALC880 are:

- z **High-performance DACs with 100dB S/N ratio**
- z **8 DAC channels support 16/20/24-bit PCM format for 5.1 audio solution**
- z **16/20/24-bit S/PDIF-OUT supports 44.1K/48K/96kHz sample rate**
- z **Compatible with AC'97**
- z **Meets Microsoft WHQL/WLP 2.0 audio requirements**

The board provides 5.1 channels audio phone jacks on rear I/O port, and amplified speaker out and Line-in/MIC-in ports for front I/O panel through optional cable.

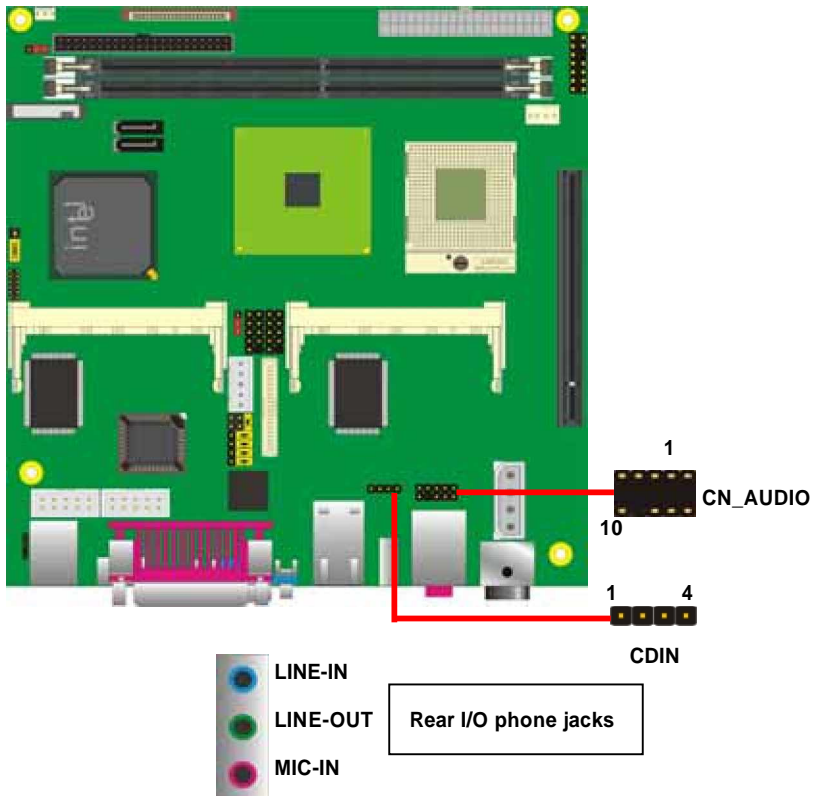

**Connector: CN\_AUDIO**

Type: 10-pin (2 x 5) 1.27mm x 2.54mm-pitch header

Pin	Description	Pin	Description
1	MIC_L	2	Ground
3	MIC_R	4	AVCC
5	Speaker_R	6	MIC Detect
7	SENSE	8	N/C
9	Speaker_L	10	Speaker Detect

**Connector: CDIN**

Type: 4-pin header (pitch = 2.54mm)

Pin	Description
1	CD – Left
2	Ground
3	Ground
4	CD – Right

## 2.12 <GPIO Interface>

The board provides a programmable 8-bit digital I/O interface; you can use this general purpose I/O port for system control like POS or KIOSK.

Connector: **CN\_DIO**

Type: 12-pin (6 x 2) 1.27mm x 2.54mm-pitch header

Pin	Description	Pin	Description
1	Ground	2	Ground
3	GP10	4	GP14
5	GP11	6	GP15
7	GP12	8	GP16
9	GP13	10	GP17
11	VCC	12	+12V

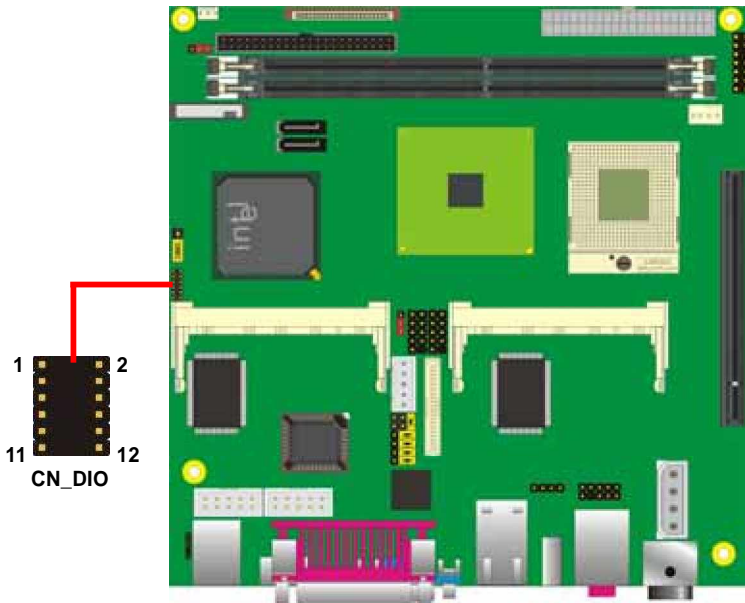

## 2.13 <Power Supply>

### 2.13.1 <Power Input>

The board requires DC 12V input with 4-pin mini DIN connector on rear I/O panel (2801450B Only) the input voltage range is from 8V to 21V, or onboard 24-pin ATX2.0 (2801450A only) , for the input current, please take a reference of the power consumption report on appendix.

Connector: **DC\_IN (2801450B only)**

Type: 4-pin DC power connector

Pin	Description	Pin	Description
1	+12V	2	+12V
3	Ground	4	Ground

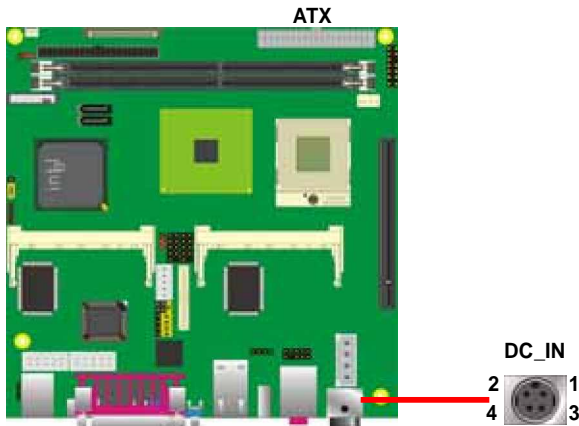

Connector: **ATX**

Type: 24-pin ATX power connector

PIN assignment			
1	3.3V	13	3.3V
2	3.3V	14	-12V
3	GND	15	GND
4	5V	16	PS_ON
5	GND	17	GND
6	5V	18	GND
7	GND	19	GND
8	PW_OK	20	-5V
9	5V_SB	21	5V
10	12V	22	5V
11	12V	23	5V
12	3.3V	24	GND

### 2.13.2 <Power Output>

The board provides one 4-pin AT connector for +5V/+12V output for powering your HDD, CDROM or other devices.

Connector: **CN\_BPWR (2801450B only)**

Type: 4-pin P-type connector for +5V/+12V **output**

Pin	Description	Pin	Description	Pin	Description	Pin	Description
1	+5V	2	Ground	3	Ground	4	+12V

*Note: Maximum output voltage: 12V/5A & 5V/3A*

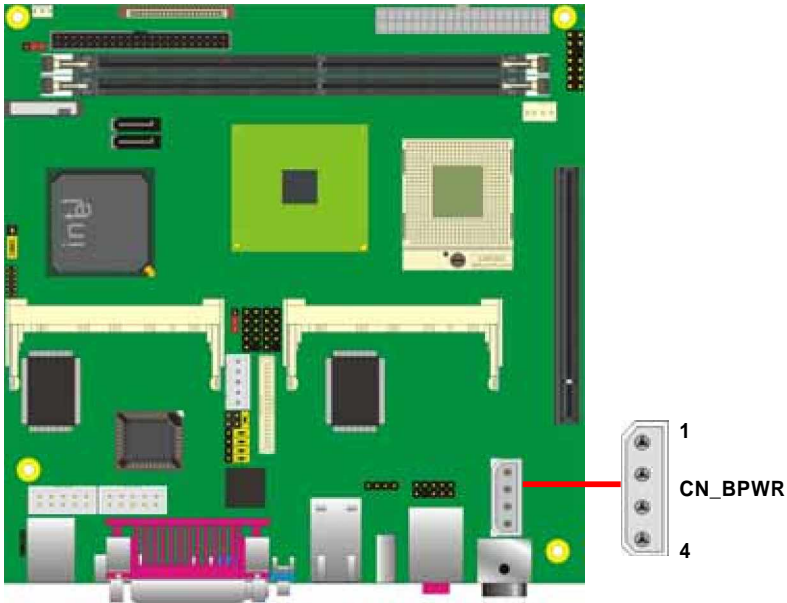



## 2.14 <Switch and Indicator>

The **JFRNT** provides front control panel of the board, such as power button, reset and beeper, etc. Please check well before you connecting the cables on the chassis.

Connector: **JFRNT**

Type: onboard 14-pin (2 x 7) 2.54-pitch header

Function	Signal	PIN		Signal	Function
IDE LED	HDLED+	1	2	PWRLED+	Power LED
	HDLED-	3	4	N/C	
Reset	Reset+	5	6	PWRLED-	Speaker
	Reset-	7	8	SPK+	
N/C		9	10	N/C	
Power	PWRBT-	11	12	N/C	
Button	PWRBT+	13	14	SPK-	

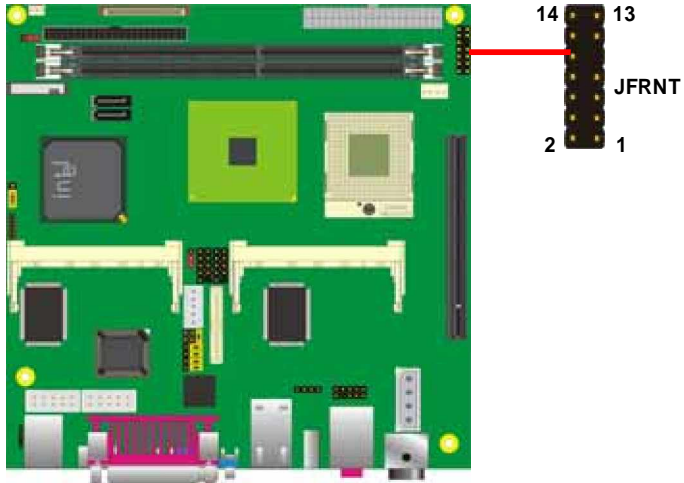

## Chapter 3 <System Setup>

### 3.1 <Video Memory Setup>

Based on Intel® 945GM chipset with GMA (Graphic Media Accelerator) 950, the board supports Intel® DVMT (Dynamic Video Memory Technology) 3.0, which would allow the video memory to be allocated up to 224MB.

To support DVMT, you need to install the Intel GMA 950 Driver with supported OS.

#### BIOS Setup:

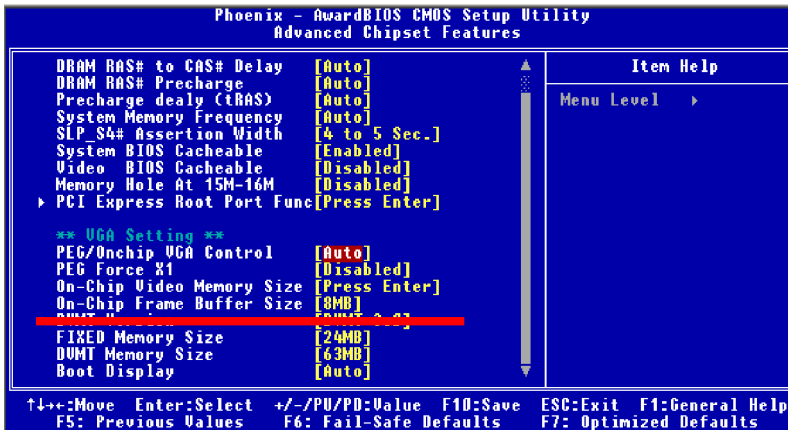

**On-Chip Video Memory Size:** This option combines three items below for setup.

#### On-Chip Frame Buffer Size:

This item can let you select video memory which been allocated for legacy VGA and SVGA graphics support and compatibility. The available option is **1MB** and **8MB**.

#### Fixed Memory Size:

This item can let you select a static amount of page-locked graphics memory which will be allocated during driver initialization. Once you select the memory amount, it will be no longer available for system memory.

#### DVMT Memory Size:

This item can let you select a maximum size of dynamic amount usage of video memory, the system would configure the video memory depends on your application, this item is strongly recommend to be selected as **MAX DVMT**.

**Fixed + DVMT Memory Size:**

You can select the fixed amount and the DVMT amount at the same time for a guaranteed video memory and additional dynamic video memory, please check the table below for available setting.

System Memory	On-Chip Frame Buffer Size	Fixed Memory Size	DVMT Memory Size	Total Graphic Memory
128MB~255MB	1MB	32MB	0MB	32MB
	1MB	0MB	32MB	32MB
	8MB	32MB	0MB	32MB
	8MB	0	32MB	32MB
256MB~511MB	1MB	64MB	0MB	64MB
	1MB	0	64MB	64MB
	1MB	128MB	0MB	128MB
	1MB	0	128MB	128MB
	1MB	64MB	64MB	128MB
	8MB	64MB	0MB	64MB
	8MB	0	64MB	64MB
	8MB	128MB	0MB	128MB
	8MB	0	128MB	128MB
	8MB	64MB	64MB	128MB
512MB upper	1MB	64MB	0	64MB
	1MB	0	64MB	64MB
	1MB	128MB	0	128MB
	1MB	0	128MB	128MB
	1MB	64MB	64MB	128MB
	8MB	64MB	0	64MB
	8MB	0	64MB	64MB
	8MB	128MB	0	128MB
	8MB	0	128MB	128MB
8MB	64MB	64MB	128MB	

Notice:

1. The On-Chip Frame Buffer Size would be included in the Fixed Memory.

Please select the memory size according to this table.

## Chapter 4 <BIOS Setup>

The motherboard uses the Award BIOS for the system configuration. The Award BIOS in the single board computer is a customized version of the industrial standard BIOS for IBM PC AT-compatible computers. It supports Intel x86 and compatible CPU architecture based processors and computers. The BIOS provides critical low-level support for the system central processing, memory and I/O sub-systems.

The BIOS setup program of the single board computer let the customers modify the basic configuration setting. The settings are stored in a dedicated battery-backed memory, NVRAM, retains the information when the power is turned off. If the battery runs out of the power, then the settings of BIOS will come back to the default setting.

The BIOS section of the manual is subject to change without notice and is provided here for reference purpose only. The settings and configurations of the BIOS are current at the time of print, and therefore they may not be exactly the same as that displayed on your screen.

To activate CMOS Setup program, press **DEL** key immediately after you turn on the system. The following message "Press DEL to enter SETUP" should appear in the lower left hand corner of your screen. When you enter the CMOS Setup Utility, the Main Menu will be displayed as **Figure 4-1**. You can use arrow keys to select your function, press **Enter** key to accept the selection and enter the sub-menu.

**Figure 4-1** CMOS Setup Utility Main Screen



(This Page is Left for Blank)

## Appendix A <I/O Port Pin Assignment>

### A.1 <IDE Port>

Connector: IDE1

Type: 44-pin (22 x 2) box header

Pin	Description	Pin	Description
1	Reset	2	Ground
3	D7	4	D8
5	D6	6	D9
7	D5	8	D10
9	D4	10	D11
11	D3	12	D12
13	D2	14	D13
15	D1	16	D14
17	D0	18	D15
19	Ground	20	N/C
21	REQ	22	Ground
23	-IOW	24	Ground
25	-IOR	26	Ground
27	IORDY	28	Ground
29	DACK	30	Ground
31	IDEIRQ	32	N/C
33	A1	34	P66DET
35	A0	36	A2
37	-CS1	38	-CS3
39	-HD LED1	40	Ground
41	+5V	42	+5V
43	Ground	44	Ground

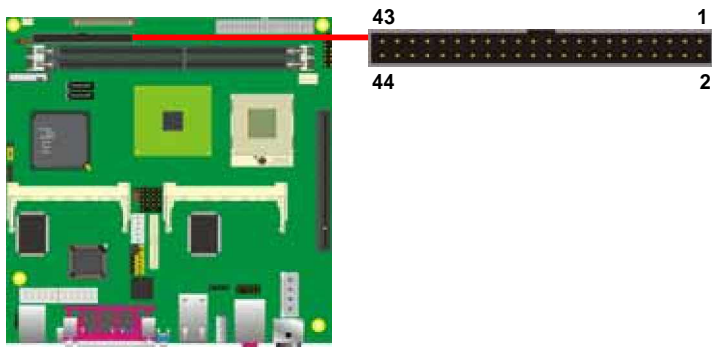

## A.2 <Serial ATA Port>

Connector: **SATA1/2**

Type: 7-pin wafer connector

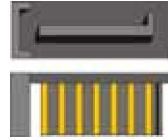

1	2	3	4	5	6	7	8	9
GND	RSATA_TXP1	RSATA_TXN1	GND	RSATA_RXN1	RSATA_RXP1	GND	GND	GND

## A.3 <Floppy Port>

Connector: **FDD**

Type: 26-pin connector



Pin	Description	Pin	Description
1	VCC	2	INDEX
3	VCC	4	DR0
5	VCC	6	DSKCHG
7	N/C	8	N/C
9	N/C	10	MTR0
11	DRVDE0	12	DIR
13	N/C	14	STEP
15	Ground	16	WRITE DATA
17	Ground	18	WRITE GATE
19	Ground	20	TRAK 0
21	N/C	22	WRPT0
23	Ground	24	RDATA-
25	Ground	26	HDSEL

## A.4 <IrDA Port>

Connector: **CN\_IR**

Type: 5-pin header for SIR Ports

Pin	Description
1	VCC
2	N/C
3	IRRX
4	Ground
5	IRTX



## A.5 <Serial Port>

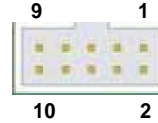

Connector: **COM1/2**

Type: 9-pin D-sub male connector on bracket

Pin	Description	Pin	Description
1	DCD- /485-	6	DSR
2	SIN- /485+	7	RTS
3	SO- /422+	8	CTS
4	DTR- /422-	9	RI
5	Ground		



Connector : **LPT**

Type :25-Pin D-Sub female Connector on bracket

Pin	Description	Pin	Description
1	-PSTB	2	PRO0
3	PRO1	4	PRO2
5	PRO3	6	PRO4
7	PRO5	8	PRO6
9	PRO7	10	ACK-
11	BUSY	12	PE
13	SLCT	14	AFD-
15	ERR-	16	INT-
17	SLIN-	18	Ground
19	Ground	20	I/O Ground
21	Ground	22	Ground
23	Ground	24	Ground
25	Ground	26	N/C



### A.6 <VGA Port>

Connector: **CRT**

Type: 15-pin D-sub female connector on bracket

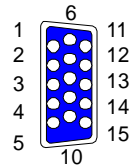

Pin	Description	Pin	Description	Pin	Description
1	RED	6	Ground	11	N/C
2	GREEN	7	Ground	12	DDCDA
3	BLUE	8	Ground	13	HSYNC
4	N/C	9	N/C	14	VSYNC
5	Ground	10	Ground	15	DDCCLK

### A.7 <LAN Port>

Connector: **RJ45**

Type: RJ45 connector with LED on bracket



Pin	1	2	3	4	5	6	7	8
Description	MI0+	MI0-	MI1+	MI2+	MI2-	MI1-	MI3+	MI3-

### A.8 < USB Interface >

Connector: **CN\_USB**

Type: 10-pin (5 x 2) header for dual USB Ports

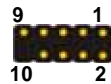

Pin	Description	Pin	Description
1	VCC	2	VCC
3	Data0-	4	Data1-
5	Data0+	6	Data1+
7	Ground	8	Ground
9	Ground	10	N/C

## Appendix B <Flash BIOS>

### B.1 <Flash Tool>

The board is based on Award BIOS and can be updated easily by the BIOS auto flash tool. You can download the tool online at the address below:

<http://www.phoenix.com/en/home/>

File name of the tool is "awdf flash.exe", it's the utility that can write the data into the BIOS flash ship and update the BIOS.

### B.2 <Flash BIOS Procedure>

1. Please make a bootable floppy disk.
2. Get the last .bin files you want to update and copy it into the disk.
3. Copy awardflash.exe to the disk.
4. Power on the system and flash the BIOS. (Example: C:/ awardflash XXX.bin)
5. Restart the system.

Any question about the BIOS re-flash please contact your distributors or visit the web-site at below:

<http://www.globalamericaninc.com/>

## Appendix C <System Resources>

### C1.<I/O Port Address Map>

[00000000 - 0000000F]	Direct memory access controller
[00000000 - 00000CF7]	PCI bus
[00000010 - 0000001F]	Motherboard resources
[00000020 - 00000021]	Programmable interrupt controller
[00000022 - 0000003F]	Motherboard resources
[00000040 - 00000043]	System timer
[00000044 - 0000005F]	Motherboard resources
[00000060 - 00000060]	Standard 101/102-Key or Microsoft Natural PS/2 Keyboard
[00000061 - 00000061]	System speaker
[00000062 - 00000063]	Motherboard resources
[00000064 - 00000064]	Standard 101/102-Key or Microsoft Natural PS/2 Keyboard
[00000065 - 0000006F]	Motherboard resources
[00000070 - 00000073]	System CMOS/real time clock
[00000074 - 0000007F]	Motherboard resources
[00000080 - 00000090]	Direct memory access controller
[00000091 - 00000093]	Motherboard resources
[00000094 - 0000009F]	Direct memory access controller
[000000A0 - 000000A1]	Programmable interrupt controller
[000000A2 - 000000BF]	Motherboard resources
[000000C0 - 000000DF]	Direct memory access controller
[000000E0 - 000000EF]	Motherboard resources
[000000F0 - 000000FF]	Numeric data processor
[000001F0 - 000001F7]	Primary IDE Channel
[00000200 - 00000200]	Standard Game Port
[00000201 - 00000207]	Standard Game Port
[00000274 - 00000277]	ISAPNP Read Data Port
[00000279 - 00000279]	ISAPNP Read Data Port
[000002F8 - 000002FF]	Communications Port (COM2)
[00000378 - 0000037F]	Printer Port (LPT1)
[000003B0 - 000003BB]	Mobile Intel(R) 945GM Express Chipset Family
[000003C0 - 000003DF]	Mobile Intel(R) 945GM Express Chipset Family
[000003F0 - 000003F5]	Standard floppy disk controller
[000003F6 - 000003F6]	Primary IDE Channel
[000003F7 - 000003F7]	Standard floppy disk controller
[000003F8 - 000003FF]	Communications Port (COM1)
[00000400 - 000004BF]	Motherboard resources

[000004D0 - 000004D1]	Motherboard resources
[00000500 - 0000051F]	Intel(R) 82801G (ICH7 Family) SMBus Controller - 27DA
[00000778 - 0000077B]	Printer Port (LPT1)
[00000800 - 0000087F]	Motherboard resources
[00000880 - 0000088F]	Motherboard resources
[00000A79 - 00000A79]	ISAPNP Read Data Port
[00000D00 - 0000FFFF]	PCI bus
[0000D000 - 0000DFFF]	Intel(R) 82801G (ICH7 Family) PCI Express Root Port - 27D0
[0000DF00 - 0000DF1F]	Intel(R) PRO/1000 PL Network Connection
[0000F500 - 0000F50F]	Intel(R) 82801GBM/GHM (ICH7-M Family) Serial ATA Storage Controller - 27C4
[0000F600 - 0000F603]	Intel(R) 82801GBM/GHM (ICH7-M Family) Serial ATA Storage Controller - 27C4
[0000F700 - 0000F707]	Intel(R) 82801GBM/GHM (ICH7-M Family) Serial ATA Storage Controller - 27C4
[0000F800 - 0000F803]	Intel(R) 82801GBM/GHM (ICH7-M Family) Serial ATA Storage Controller - 27C4
[0000F900 - 0000F907]	Intel(R) 82801GBM/GHM (ICH7-M Family) Serial ATA Storage Controller - 27C4
[0000FA00 - 0000FA0F]	Intel(R) 82801G (ICH7 Family) Ultra ATA Storage Controllers - 27DF
[0000FB00 - 0000FB1F]	Intel(R) 82801G (ICH7 Family) USB Universal Host Controller - 27CB
[0000FC00 - 0000FC1F]	Intel(R) 82801G (ICH7 Family) USB Universal Host Controller - 27CA
[0000FD00 - 0000FD1F]	Intel(R) 82801G (ICH7 Family) USB Universal Host Controller - 27C9
[0000FE00 - 0000FE1F]	Intel(R) 82801G (ICH7 Family) USB Universal Host Controller - 27C8
[0000FF00 - 0000FF07]	Mobile Intel(R) 945GM Express Chipset Family

## C2.<Memory Address Map>

[00000000 - 0009FFFF]	System board
[000A0000 - 000BFFFF]	Mobile Intel(R) 945GM Express Chipset Family
[000A0000 - 000BFFFF]	PCI bus
[000C0000 - 000DFFFF]	PCI bus
[000D1000 - 000D3FFF]	System board
[000E0000 - 000EFFFF]	System board
[000F0000 - 000F7FFF]	System board
[000F8000 - 000FBFFF]	System board
[000FC000 - 000FFFFF]	System board
[00100000 - 7F6DFFFF]	System board
[7F6E0000 - 7F6FFFFF]	System board
[7F700000 - FEBFFFFF]	PCI bus
[D0000000 - DFFFFFFF]	Mobile Intel(R) 945GM Express Chipset Family
[E0000000 - EFFFFFFF]	Motherboard resources
[FDB00000 - FD8FFFFF]	Intel(R) 82801G (ICH7 Family) PCI Express Root Port - 27D0
[FDDFF000 - FDDFFFFF]	OHCI Compliant IEEE 1394 Host Controller
[FDE00000 - FDEFFFFF]	Intel(R) 82801G (ICH7 Family) PCI Express Root Port - 27D0
[FDEE0000 - FDEFFFFF]	Intel(R) PRO/1000 PL Network Connection
[FDF00000 - FDF7FFFF]	Mobile Intel(R) 945GM Express Chipset Family
[FDF80000 - FDFBFFFF]	Mobile Intel(R) 945GM Express Chipset Family
[FDFF8000 - FDFFBFFF]	Microsoft UAA Bus Driver for High Definition Audio
[FDFFE000 - FDFFE3FF]	Intel(R) 82801GBM/GHM (ICH7-M Family) Serial ATA Storage Controller - 27C4
[FDFFF000 - FDFFF3FF]	Intel(R) 82801G (ICH7 Family) USB2 Enhanced Host Controller - 27CC
[FEB80000 - FEBFFFFF]	Mobile Intel(R) 945GM Express Chipset Family
[FEC00000 - FEC00FFF]	System board
[FED13000 - FED1DFFF]	System board
[FED20000 - FED8FFFF]	System board
[FEE00000 - FEE00FFF]	System board
[FFB00000 - FFB7FFFF]	System board
[FFB80000 - FFBFFFFF]	Intel(R) 82802 Firmware Hub Device
[FFF00000 - FFFFFFFF]	System board

## C3.<System IRQ & DMA Resources>

### DMA:

- 2 Standard floppy disk controller
- 4 Direct memory access controller

### IRQ:

- (ISA) 0 System timer
- (ISA) 1 Standard 101/102-Key or Microsoft Natural PS/2 Keyboard
- (ISA) 3 Communications Port (COM2)
- (ISA) 4 Communications Port (COM1)
- (ISA) 6 Standard floppy disk controller
- (ISA) 8 System CMOS/real time clock
- (ISA) 9 Microsoft ACPI-Compliant System
- (ISA) 12 PS/2 Compatible Mouse
- (ISA) 13 Numeric data processor
- (ISA) 14 Primary IDE Channel
- (PCI) 15 Intel(R) 82801G (ICH7 Family) SMBus Controller - 27DA
- (PCI) 16 Intel(R) 82801G (ICH7 Family) PCI Express Root Port - 27D0
- (PCI) 16 Intel(R) 82801G (ICH7 Family) USB Universal Host Controller - 27CB
- (PCI) 16 Intel(R) PRO/1000 PL Network Connection
- (PCI) 16 Microsoft UAA Bus Driver for High Definition Audio
- (PCI) 16 Mobile Intel(R) 945GM Express Chipset Family
- (PCI) 16 OHCI Compliant IEEE 1394 Host Controller
- (PCI) 18 Intel(R) 82801G (ICH7 Family) USB Universal Host Controller - 27CA
- (PCI) 19 Intel(R) 82801G (ICH7 Family) USB Universal Host Controller - 27C9
- (PCI) 19 Intel(R) 82801GBM/GHM (ICH7-M Family) Serial ATA Storage Controller - 27C4
- (PCI) 23 Intel(R) 82801G (ICH7 Family) USB Universal Host Controller - 27C8
- (PCI) 23 Intel(R) 82801G (ICH7 Family) USB2 Enhanced Host Controller - 27CC

The GPIO can be programmed with the MSDOS debug program using simple IN/OUT commands. The following lines show an example how to do this.

GPIO0.....GPIO7 bit0.....bit7

```
-o 2E 87                ;enter configuration
-o 2E 87
-o 2E 29
-o 2E 40                ;enable GPIO function
-o 2E 07
-o 2E 07                ;enable GPIO configuration
-o 2E F0
-o 2F xx                ;set GPIO as input/output; set '1' for input,'0' for output
-o 2E F1
-o 2F xx                ;if set GPIO's as output,in this register its value can be set
```

Optional :

```
-o 2E F2
-o 2F xx                ; Data inversion register ; '1' inverts the current value of the
                        bits ,'0' leaves them as they are
-o 2E 30
-o 2F 01                ; active GPIO's
```

For further information ,please refer to Winbond W83627HF datasheet.

## Appendix D <Programming Watchdog Timer >

The watchdog timer makes the system auto-reset while it stops to work for a period. The integrated watchdog timer can be setup as system reset mode by program.

### Timeout Value Range

- 1 to 255
- Second or Minute

### Program Sample

Watchdog timer setup as system reset with 5 second of timeout

```
-o 2E 87           ;enter configuration
-o 2E 87
-o 2E 07
-o 2F 08           ;enter Logical Device 8
-o 2E F5
-o 2F 00           ;set as Second* Minute: bit 3 = 1; Second: bit 3 = 0
-o 2E F6
-o 2F 05           ;set as 5 Second
```



# Appendix E <How to setting RS-422 & RS-485>

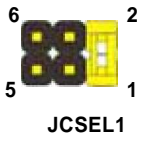

RS-232

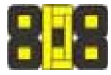

RS-485

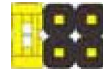

RS-422

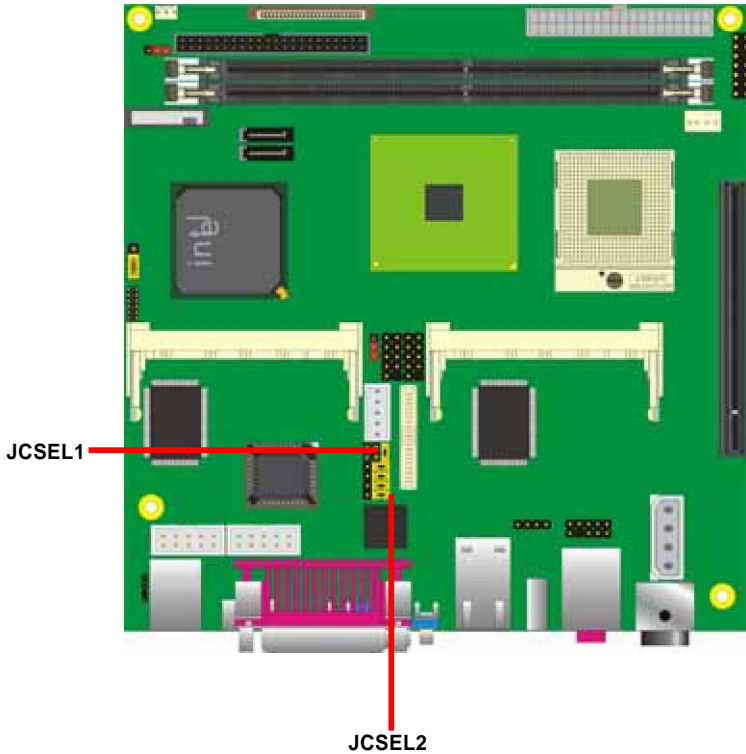
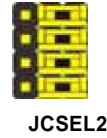
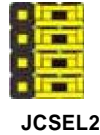

Any advice or comments about our products and service, or anything we can help you with please don't hesitate to contact with us. We will do our best to support you for your products, projects and business

### **Global American Inc.**

Address 17 Hampshire Drive  
Hudson, NH 03051

TEL Toll Free (U.S. Only) 800-833-8999  
(603)886-3900

FAX (603)886-4545

Website <http://www.globalamericaninc.com>

E-Mail [salesinfo@globalamericaninc.com](mailto:salesinfo@globalamericaninc.com)

