



Model: **PCC435**

Colour Digital CCD
560x Zoom Camera

Before you begin

- Please unpack the box carefully and identify that all the parts are present.
- Do not open the camera housing. This will void the warranty and break the warranty seal inside the camera.
- Make sure you use only the recommended power supply. Damage caused to the camera by incorrect voltage or wiring is not covered by the warranty.

Model:

PCC435

Colour Digital CCD
560x Zoom Camera

CONTENTS

1. SAFETY PRECAUTIONS	3
2. INTRODUCTION	4
3. FEATURES	5
4. ACCESSORIES	6
5 NAME and FUNCTION of EACH PART	7
6. INSTALLATION	10
6.1 Native Keyboard Installation	11
6.2 PELCO Keyboard (or compatible) Installation	11
7. OPERATING PROCEDURE	12
7.1 Native Keyboard Operation	12
7.2 PELCO Keyboard (or compatible) Operation	13
8. SYSTEM SETUP	15
8.1 OSD (On Screen Display) FORMAT	15
8.2 MENU DESCRIPTIONS	18
8.3 SUB MENU DESCRIPTIONS	19
9. Camera Control Command Protocol	26
9.1 Communication Format	26
9.2 PC Command	27
9.3 Key Code Table	58
10. SPECIFICATIONS	60

The author assumes no responsibility for any errors or omissions that may appear in this document nor does the author make a commitment to update the information herein.

1. SAFETY PRECAUTIONS

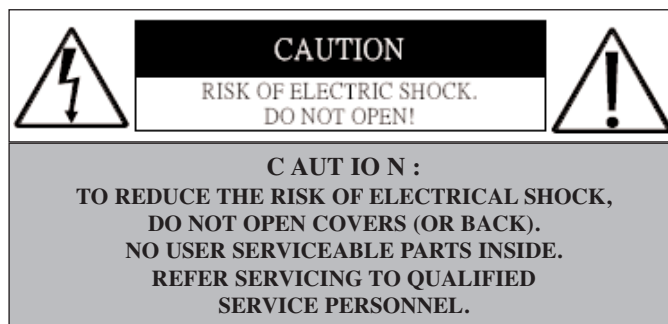

It is advised to read the Safety Precaution Guide through carefully before operating the product, to prevent any possible danger.

 **WARNING:** This symbol is intended to alert the user to the presence of un-insulated “dangerous voltage”.

 **CAUTION:** This symbol is intended to alert the user to presence of important operating and maintenance (Servicing) instructions in the literature accompanying the appliance.

 **Disposal of Old Electrical & Electronic Equipment (Applicable in the European Union and other European countries with separate collection systems).**

This symbol on the product or on its packaging indicates that this product shall not be treated as household waste. By ensuring this product is disposed of correctly, you will help prevent potential negative consequences for the environment and human health, which could otherwise be caused by inappropriate waste handling of this product. The recycling of materials will help to conserve natural resources. For more detailed information about recycling of this product, please contact your local city office, your household waste disposal service or the shop where you purchased the product.

Do not touch the zoom lens directly with your hands or fingers. Clean the zoom lens using soft cloth moistened with alcohol to wipe off any dust.

Please be extra careful not to shake the product and avoid places where frequent vibrations or shocks may occur.

Do not install the product in extreme temperature conditions.

Only use the camera under conditions where temperatures are between -10° and $+50^{\circ}$.

Do not install the product in an environment where the humidity is high.

Do not spill liquid of any kind on the product.

If it gets wet, wipe it dry immediately. Alcohol or beverage can contain minerals that corrode the electronic components.

When minimum brightness of 0.01 Lux cannot be achieved during the night, please install appropriate light fixtures.

If any abnormal operation or accident occurs, disconnect the device and contact your dealer or the nearest service center.

Do not simultaneously connect to the DC 12V IN Jack (from the power source connector) and the DC 12V IN (from the 6-pin Mini-DIN connector), as error may occur.

2. INTRODUCTION

The auto-focus camera is a compact CCTV camera designed for easy integration into surveillance systems. The Camera's built-in 35x Optical zoom lens spells added user convenience since there is no need for separate adjustment of the focal distance. Current applications include highway traffic control, plus security surveillance in such locations as elevators and parking lots.

The advanced DSP technology allows intelligent control for clearer, detailed pictures. Additionally, the user can perform remote Zoom/ Focus/ Iris/ White Balance operations via either RS-422/RS-485 or RS-232 (optional) interface. In combination with a highly sensitive Sony 1/4" Ex View CCD sensor, these features make the auto-focus camera is particularly suitable for surveillance.

- **Built-in Optical Zoom Lens with Digital Zoom**

The built-in 35x optical zoom lens is highly reliable and offers auto focus and auto iris functions. The camera also includes 16x digital zoom for a maximum of 560x combined optical and digital zoom.

- **Day & Night**

ICR function provides change from color to B/ W mode automatically or manually for day and night 24-hour surveillance. Perfect use for Bank, Treasury, ATM, Road Station, Port, Square, Warehouse, and etc. The chassis is equipped with IR cut filter change mechanism. When Day & Night mode is set to "AE" on the OSD menu of the camera, the camera will turn the IR Cut Filter according to exposure of the object. When the Day & Night mode is set to "Sensor" on the OSD menu of the camera, the camera will turn the IR Cut Filter according to the sensitivity of the SENSOR.

- **Setup Menu Function via Keys**

Pushing keys on the rear panel of the camera can set each setup menu function. Setup menu functions are displayed on screen display (OSD).

- **Camera Control via either RS-422/RS-485 or RS-232 (optional) interface**

Camera control can adjust the camera's zoom, focus, Iris and white balance via either RS-422/RS-485 or RS-232 (optional) interface.

- **Built-in Wire Remote Control Interface including Wet Contact and A/D Key**

Wet contact interface is to control zooming and focusing. There are Menu, Tele, Wide, Near, Far and On/Off signals via A/D key control. The A/D Key control signal can be sent from Wire Remote Controller (optional).

- **Built-in Pan Tilt Zoom (PTZ) Protocols**

The camera automatically recognizes four protocols, such as native protocol, PELCO (D and P protocol) and LG protocol. Camera parameters can easily be setup via native keyboard (RS-485) or PELCO keyboard (RS-422).

3. FEATURES

- 1/4" High Resolution Color CCD Camera.
- Supports powerful function: Auto Iris Control (AIC), Auto White Balance (AWB), Auto Gain Control (AGC), Auto Back Light Compensation (ABLC), Flickerless (FL) and Auto Focus (AF).
- 35x Optical Zoom Lens and 16x Digital Zoom. (Total 560x Zoom).
- Day & Night time vision (with IR Cut Filter change mechanism) including Day / Night Control Interface.
- On Screen Display (OSD) Setup Menu.
- Camera Control via either RS-422/RS-485 or RS-232.
- Supports PELCO (D and P)/ LG Protocol.
- Wire Remote Control (6 Pin Circular Connector) including wet contact interface to control zooming and focusing and A/D Key Control for Menu, Tele, Wide, Near, Far and On/Off signals.
- Built-in 5 keys to Control Zooming and Focusing Function, and Setup Menu adjustment.
- Built-in Audio.

4. ACCESSORIES

- Mounting Block x1 and Screws x2
- User's Manual x1

5 NAME and FUNCTION of EACH PART

Front View

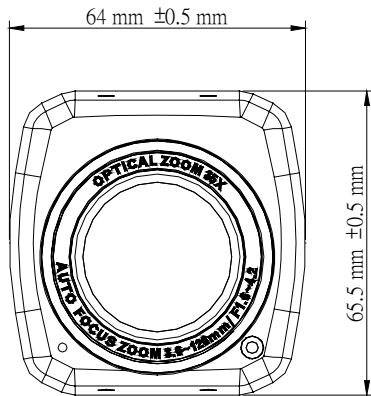

Figure 5-1

Side View

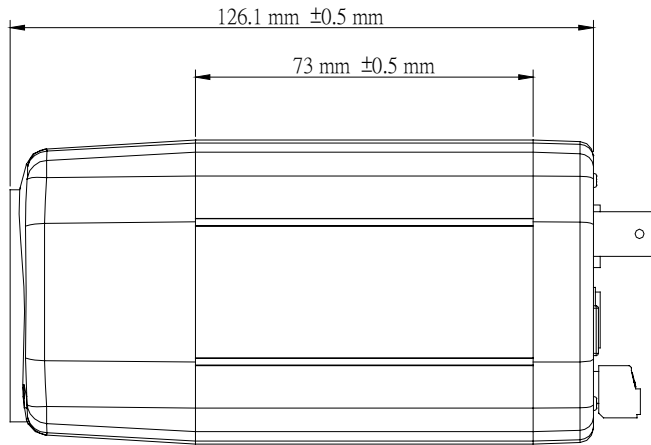

Figure 5-2

Rear View

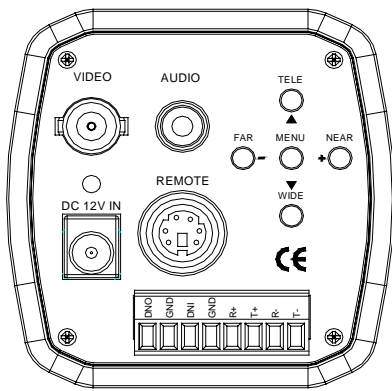

Figure 5-3

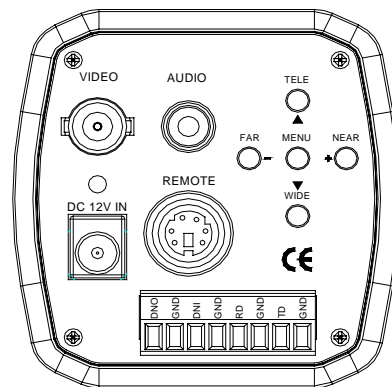

Figure 5-4

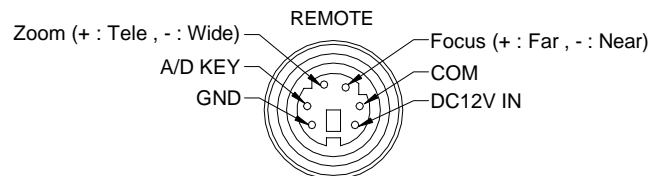

Figure 5-5

⚠ CAUTION: Do not simultaneously connect to the DC 12V IN Jack (from the power source connector) and the DC 12V IN (from the 6-pin Mini-DIN connector), as error may occur.

- (1). Power Input : DC 12V \pm 10% (Recommendation 12V \pm 0.5V) Max 4.1W.
- (2). Video Output : Composite Video 1Vp-p, 75 Ohms, BNC
- (3). Audio Output : 2Vp-p, 50 Ohms
- (4). 5 Keys Control :

Name	Function
Tele/▲	Zoom Tele or Up (▲)
Wide/▼	Zoom Wide or Down (▼)
Near/+	Focus Near or Increase (+)
Far/—	Focus Far or Decrease (—)
Menu	Enter or Exit Setup Menu

- (5). Remote Control Interface (6 Pin Circular Connector) : refer to figure 5-5

Name	I/O	Note
Zoom (+ : Tele, — : Wide)	Input	\pm 6V (+3V~+13V, —3V~—13V)
Focus (+ : Far, — : Near)	Input	\pm 6V (+3V~+13V, —3V~—13V)
COM		Pair Ground for Zoom, Focus
A/D Key	Input	A/D (Voltage Divide) Control
GND		Pair Ground for Power Supply and A/D Key
DC 12V IN	Input	Power Supply DC 12V \pm 10% (Recommendation 12V \pm 0.5V)

There are Menu, Tele, Wide, Near, Far and On/ Off signals via A/ D key.

- (6). Camera Control : 2.4K/ 4.8K/ 9.6K/ 19.2K BPS (Please refer to OSD setup MENU).
Optional: RS-422/ RS-485, refer to figure 5-3

Name	Function
R+, R-, T+, T-	Use For RS-422/RS-485 Control

- Optional: RS-232, refer to figure 5-4

Name	Function
RD, TD, GND	Use for RS-232 Control

- (7). Day & Night Control : refer to figure 5-3 or 5-4

Name	Function
DAY&NIGHT OUTPUT (DNO)	5V / 10mA: IR LED ON (NIGHT)
	0V: IR LED OFF (DAY)
DAY&NIGHT EXTERNAL INPUT (DNI)	Open Contact: DAY
	Close Contact (Close to GND): NIGHT

- **Day & Night Output**

This function will turn on the external IR LED lamp according to the position of IR cut filter.

- **Day & Night Output**

5V / 10mA: IR LED ON (NIGHT)

0V: IR LED OFF (DAY)

- **Day & Night External Input**

When Day & Night mode is set to "External" on the OSD menu of the camera, this function will be switched to DAY mode or NIGHT mode according to the Day & Night signal from the external light sensor or the IR LED lamp.

Open Contact: DAY

Close Contact (Close to GND): NIGHT

6. INSTALLATION

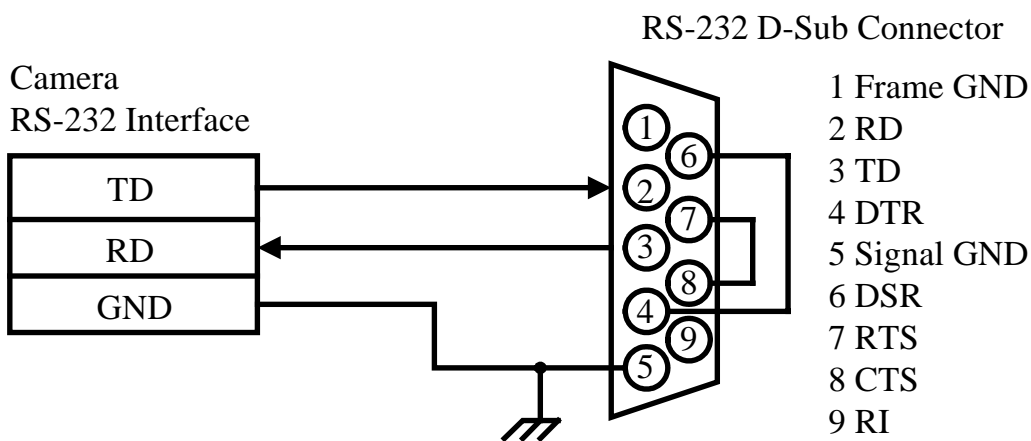

Figure 6-1

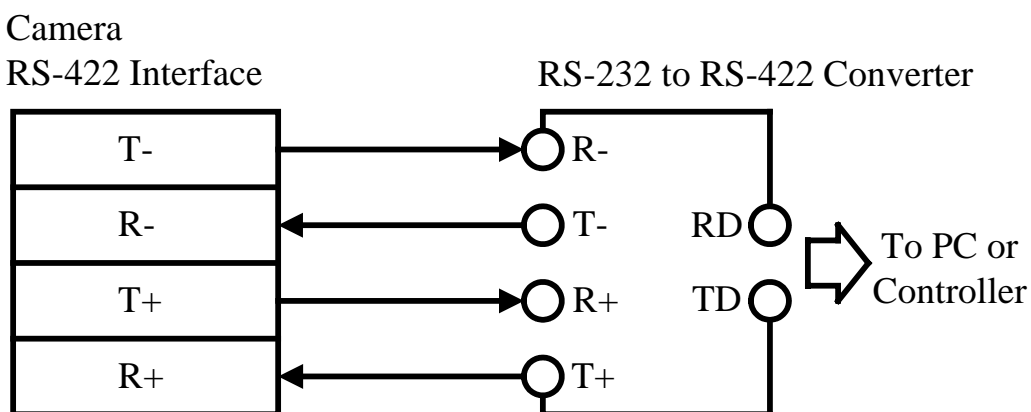

Figure 6-2

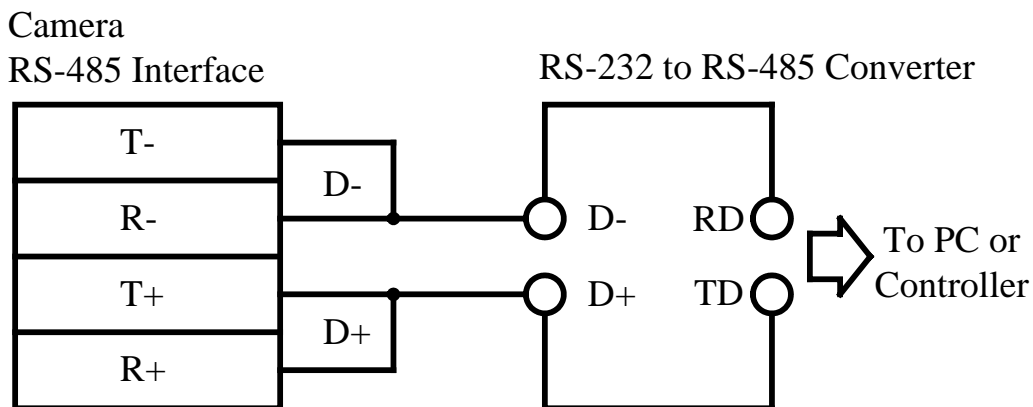

Figure 6-3

6.1 Native Keyboard Installation

- RS-485 interface is used for communicating native keyboard. Refer to Figure 6-3; connect R+ and T+ of the camera together; connect R+ and T+ of the camera to D+ of the native keyboard. Connect R- and T- of the camera together; connect R- and T- of the camera to D- of the native keyboard.
- User could adjust Camera ID via rear panel keys or via remote commands. Protocol, Speed and Parity should only be adjusted via rear panel keys.

Communication	Setting
CAMERA ID	1 ~ 127
PROTOCOL	AUTO, NATIVE
SPEED	9600
PARITY	NONE

The speed of native keyboard is fixed (9600).

Adjusted function is only effective, after exiting the OSD setup menu.

6.2 PELCO Keyboard (or compatible) Installation

- RS-422 interface is used for communicating PELCO keyboard. Refer to Figure 6-2; connect R+ of the camera to T+ of the PELCO keyboard. Connect R- of the camera to T- of the PELCO keyboard.
- User could adjust Camera ID via rear panel keys or via remote commands. Protocol, Speed and Parity should only be adjusted via rear panel keys.

Communication	Setting
CAMERA ID	0 ~ 253 for P protocol
	1 ~ 255 for D protocol
PROTOCOL	AUTO, PELCO
SPEED	2400, 4800, 9600, 19200
PARITY	NONE

The speed of camera should be the same as the speed of the keyboard.

Adjusted function is only effective, after exiting the OSD setup menu.

NOTE: Maximum cable distance for RS-422/ RS-485 communication over 24-gauge wire is 4,000 feet (1,219 m). Recommend using shielded twisted pair cable that meets the basic requirements for EIA RS-422 / RS-485 applications.

7. OPERATING PROCEDURE

- (1) Mount the camera on the mounting bracket by using the hole on the top or bottom of the camera or by using the enclosed 8mm mounting block, furnished by 2 screws.
- (2) Connect the Video Output to the monitor or other video device via a 75 Ohms type coaxial cable.
- (3) Connect the power source, using the DC Jack (+12V DC in the jack center) or Remote Control Interface (6 Pin Circular Connector). Do not simultaneously connect to the DC 12V IN Jack (from the power source connector) and the DC 12V IN (from the 6-pin Mini-DIN connector), as error may occur.
- (4) Wait a while for the camera to power on and the zoom lens will resume to the previous power on position automatically.
- (5) Once the picture appears on the monitor, press the Zoom Tele, Zoom Wide, Focus Near, Focus Far and Setup Menu Key to obtain the best picture quality.

7.1 Native Keyboard Operation

Normal Display Mode

Native Keyboard	Camera Function
BRIGHTNESS+	Brightness +
BRIGHTNESS-	Brightness -
NEAR	Focus Near
FAR	Focus Far
Zoom TELE	Zoom Tele
Zoom WIDE	Zoom Wide
Move Joystick Left	None
Move Joystick Right	None
Move Joystick Up	None
Move Joystick Down	None

Camera Function	Native Keyboard
Accessing Main Menu	Press the MENU key
Call up the Preset Points	Enter preset number (1~128) and press GO PRESET to put camera in preset position.
Setting the Preset Points	To program, position camera, enter desired preset number (1~128), and press SET PRESET.
AUTO FOCUS Control	Press the AUTO FOCUS Key, the LED of the AUTO FOCUS lights up and press AUTO FOCUS key again, to disable the function.

OSD Setup Menu Mode

Native Keyboard	Camera Function
◀	Decrease (-)
▶	Increase (+)
▲	Cursor Up
▼	Cursor Down
BRIGHTNESS+	None
BRIGHTNESS-	None
NEAR	None
FAR	None
Zoom TELE	None
Zoom WIDE	None
Move Joystick Left	None
Move Joystick Right	None
Move Joystick Up	None
Move Joystick Down	None

- Please refer to the native keyboard manual for more information.

7.2 PELCO Keyboard (or compatible) Operation

Normal Display Mode

PELCO Keyboard	Camera Function
OPEN	Brightness +
CLOSE	Brightness -
NEAR	Focus Near
FAR	Focus Far
Twist Joystick clockwise or Zoom In	Zoom Tele
Twist Joystick counterclockwise or Zoom Out	Zoom Wide
Move Joystick Left	None
Move Joystick Right	None
Move Joystick Up	None
Move Joystick Down	None

Camera Function	PELCO Keyboard
Accessing Main Menu	Enter 95; press on the PRESET button (approximately five seconds) until the main menu appears on the screen.
Call up the Preset Points	Enter preset number (1~32, 35~82) and press PRESET to put the camera in preset position.
Setting the Preset Points	To program, position camera, enter desired preset number (1~32,35~82), and press on the PRESET button for two seconds.

OSD Setup Menu Mode

PELCO Keyboard	Camera Function
OPEN	Sub Menu Enter
CLOSE	Sub Menu Exit
NEAR	Cursor Up
FAR	Cursor Down
Twist Joystick clockwise or Zoom In	None
Twist Joystick counterclockwise or Zoom Out	None
Move Joystick Left	Decrease (-)
Move Joystick Right	Increase (+)
Move Joystick Up	Cursor Up
Move Joystick Down	Cursor Down

- Please refer to PELCO Keyboard (or compatible) manual for more information.

8. SYSTEM SETUP

8.1 OSD (On Screen Display) FORMAT

OSD DISPLAY POSITION

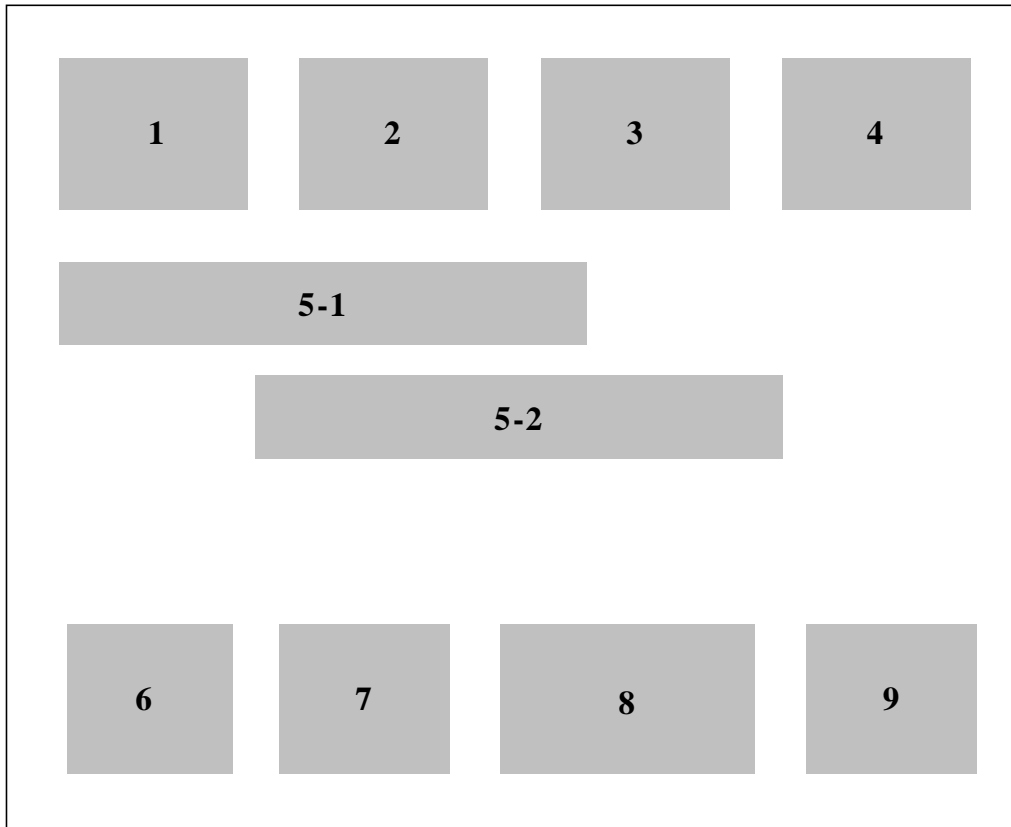

Figure 8-1

OSD DISPLAY DESCRIPTION

	FUNCTION	OSD Format	DESCRIPTION
1	FOCUS MODE	Non display	Auto Mode
		↑	Manual / Push Auto Mode
2	BACK LIGHT	Non display	Back Light OFF
		“BLC” display	BLC ON / Auto / Super BLC Mode
3	SHUTTER SPEED	Non display	Normal Shutter (NTSC: 1 / 60, PAL: 1 / 50)
		“Ff” display	Flickerless Mode
		1 / 125 . . 1 / 30,000	29 variable steps.
4	WBC MODE	AWB	AUTO White Balance
		HUE	The HUE control is valid (0 ~ 99).
		IWB	WB Preset for INDOOR
		OWB	WB Preset for OUTDOOR
		MWB	Manual WB Adjustment.
		PWB	Push Auto White Balance; turn this mode ON, the white trace automatically. Turn this mode OFF; Preserve the white of final auto tracing action (Manual).
5-1	PROTOCOL	AUTO/ NATIVE/ PELCO/LG	After power-on, information on PROTOCOL and COMM will be displayed. This information will remain on the monitor for a short interval.
	COMM	Setting string: "BBBB, P, D, S"	
5-2	STAND-BY MODE	STAND-BY	Indicate the camera stand-by during the camera's power turning ON.
6	ZOOM DISPLAY	Dx560	Digital Zoom mode
		X35	Optical Zoom mode
7	CAMERA ID	According to the identification number (000 ~ 255) for each camera, multi-point control (via PC or keyboard) is valid.	
8	USER TITLE STRING	Maximum 10 user char string	
9	BRIGHTNESS	Brightness data	

NOTE:

Setting string: "BBBB, P, D, S"

BBBB represent baud rate, it can be one of the following values:

2400, 4800, 9600, 19200

P represent parity, it can be one of the following values:

N (None), O (Odd), E (EVEN)

D represent data bits, it should be the following value:

8

S represent stop bit, it should be the following value:

1

For example, the following string specifies a baud rate of 9600, no parity, 8 data bits, and 1 stop bit:

9600, N, 8,1

8.2 MENU DESCRIPTIONS

MAIN MENU

MENU	
FOCUS SET	↔
AWB SET	↔
AE SET	↔
SPECIAL SET	↔
F OSD DISP	↔
DAY/NIGHT	↔
COMMUNICAT	↔
INITIAL SET	ON
EXIT	↔

Figure 8-2

SET UP THE MENU

- In order to display the Setup Menu on the screen, set the Menu command or press key panel.
- To select each item, by using the Zoom Tele and Zoom Wide command or using the Up (▲) and Down (▼) key panel.
- To change the data, by using the Focus Far and Focus Near command or by using the Decrease (−) and Increase (+) key panel.

8.3 SUB MENU DESCRIPTIONS

FOCUS SET

FOCUS MODE SET:

- This function is for focus mode setting.
- Set the mode to Auto, Manual, or **Push Auto**.

FOCUS DISTANCE SET:

- This function is for selection of minimum shooting distance.
- Set the Focus Distance mode to 1cm, 10cm, 50cm, 1M, **1.5M**, 3M, 5M or 10M.

ZOOM START SET:

- This function is for selection of zoom start position.
- Set the Zoom Start mode from **x1** to x34.

ZOOM END SET:

- This function is for selection of zoom end position.
- Set the Zoom End mode from x560 to x2.

ZOOM SPEED SET:

- This function is for selection of zoom speed.
- Set the Zoom Speed to slow, normal or **high**.

ZOOM TRACKING MODE SET:

- This function is for selection of zoom tracking mode.
- Set the Zoom Tracking mode to **Auto** or Manual.
- Zoom Tracking means focused zooming state.

INITIAL SET:

- If initial mode set to ON, All FOCUS function is changed to the factory setting.

RETURN TO MAIN MENU:

- Exit the FOCUS set of OSD menu and return to the main menu.

AWB SET

WB MODE SET:

- This function is for changing the WB mode.
- Set the mode to **Auto**, Hue, Indoor, Outdoor, Manual, or Push Auto.
- AUTO: WB color temperature range = 2500°K ~ 8000°K.
- Manual WB: Adjust Red and Blue gain to perform a desired White Balance.
- PUSH AUTO: Set the WB mode to Push Auto.

HUE CONTROL SET:

- This function is valid for Hue WB mode.
- Adjust the level from 0 MIN to 99 MAX.

RED GAIN SET:

- This function is valid for Manual WB mode.
- This mode is an optional adjustment function, for users to adjust special colors.

BLUE GAIN SET:

- This function is valid for Manual WB mode.
- This mode is an optional adjustment function, for users to adjust special colors.

PUSH AUTO SET:

- This function is valid for Push Auto WB mode.
- Turn this mode ON, the white trace automatically. Turn this mode OFF; Preserve the white of final auto tracing action (Manual).

INITIAL SET:

- If initial mode set to ON, All AWB function is changed to the factory setting.

RETURN TO MAIN MENU:

- Exit the AWB set of OSD menu and return to the main menu.

AE SET

AE MODE SET:

- This function is for changing the AE mode.
- Set the mode to **AUTO**, IRIS MAN, AGC MAN, or Manual.

IRIS ADJUST SET:

- This function is valid for IRIS MAN mode.
- Adjust the level from 36 MIN to 250 MAX.

AGC MAXIMUM SET / AGC ADJUST SET:

- This function is valid for AGC AUTO mode / AGC MAN mode.
- AGC AUTO means AUTO or IRIS MAN.
- Adjust the level from 28 MIN to 255 MAX.

BRIGHTNESS ADJUSTMENT SET:

- Adjust the level from 0 MIN to 99 MAX.

BACKLIGHT SET:

- Set the mode to **OFF**, ON, AUTO, or SUPER.
- Back Light Compensation (BLC) is ON:
BLC could emphasize the luminance of the BLC Area according to the BLC Level.
- AUTO BLC:
When a back light condition occurs in area1, area2, area3, or area4. The back light compensation is enabled automatically. When the back light condition disappears in that area, BLC is disabled automatically. To disable this mode, set it to OFF.

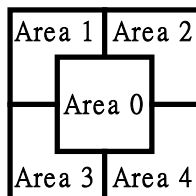

@ BLC area is Area 0.

- SUPER BLC:
BLC could emphasize the luminance of the image according to the light condition.

BLC LEVEL SET:

- This function is valid for BLC ON mode.
- Adjust the level from 0 MIN to 80 MAX.

BLC AREA SET:

- This function is valid for BLC ON or AUTO BLC mode.
- Define the main object area that is under exposure based on the average luminance of the whole image.
- Set the BLC area **Center** (area 0), Top Small (TopS) (area1+area2), Top Large (TopL) (area1+area2+area0), Bottom Small (BottomS) (area3+area4), Bottom Large (BottomL) (area3+area4+area0), Left (area1+area3) or Right (area2+area4).

FLICKERLESS SET:

- Select the mode **ON** or **OFF**. Use for preventing picture flicker.
- In case of NTSC System, Shutter Speed is 1/100 sec.
- In case of PAL System, Shutter Speed is 1/120 sec.

SHUTTER SPEED SET:

- Set the mode **Normal** (NTSC: 1/60, PAL: 1/50), 1/125, 1/150, 1/200, 1/250, 1/300, 1/350, 1/400, 1/450, 1/500, 1/600, 1/700, 1/800, 1/900, 1/1000, 1/1100, 1/1200, 1/1300, 1/1500, 1/1600, 1/1800, 1/2000, 1/2500, 1/3000, 1/3500, 1/4000, 1/6000, 1/10000, 1/30000 sec.

INITIAL SET:

- If initial mode set to ON, All AE function is changed to the factory setting.

RETURN TO MAIN MENU:

- Exit the AE set of OSD menu and return to the main menu.

SPECIAL SET

USER TITLE SET:

- This function is for setting up user title on screen display.
- Set the position of title using Near / Far Command, set the data using Tele / Wide Command.

SHARPNESS ADJUST Set:

- Adjust the level from 0 to 15.

MIRROR Set:

- Select the mode ON or **OFF**.
- This function applies only to high resolution.
- This function is only available when the Digital Zoom Mode is **OFF**.

NEGATIVE Set:

- This mode is to change color and luminance to negative.
- Select the mode ON or **OFF**.

WIDE BURST Set:

- This mode is to change color burst width for long distance application.
- Select the mode ON or **OFF**.

INITIAL SET:

- If initial mode set to ON, All SPECIAL function is changed to the factory setting.

RETURN TO MAIN MENU:

- Exit the SPECIAL set of OSD menu and return to the main menu.

F. OSD SET

FUNCTION DISP **ON** or DISP OFF

- There are Focus Mode, Back Light, Shutter Speed and WBC Mode in the function display.

CAMERA ID DISP **ON** or DISP OFF

ZOOM MAG DISP **ON** or DISP OFF

USER TITLE DISP **ON** or DISP OFF

INIT TITLE DISP **ON** or DISP OFF

BRIGHTNESS DISP **ON** or DISP OFF

DAY/ NIGHT SET

DAY/ NIGHT MODE SET:

- This function is used for Day & Night control mode setting.
- Set the mode to **AE Mode**, SENSOR mode, Day mode, Night mode, or External mode.
- If manual IRIS or manual AGC is selected, you cannot set AE mode to Day & Night control mode.

SENSOR LEVEL Set:

- Adjust the level from 0 to 255.
- The SENSOR level threshold is used for filter setting (setup result is reflected according to the sensitivity of the SENSOR).

FILTER DLY Set:

- Adjust the level from 1 to 15 seconds.
- Delay time for turning the filter.
- The function is valid to SENSOR mode.

INITIAL SET:

- If initial mode set to ON, All DAY / NIGHT function is changed to the factory setting.

RETURN TO MAIN MENU:

- Exit the DAY/ NIGHT set of OSD menu and return to the main menu.

COMMUNICATION SET

Adjusted communication function is only effective, after exiting the OSD setup menu.

Protocol Set, Speed Set and Parity Set should only be adjusted via rear panel keys.

CAMERA ID

- To connect numerous cameras, identification number is assigned to each camera for camera control (000 ~ 255: total numbers of ID are 256). ID 1 ~ 127 for native keyboard; ID 0 ~ 253 for PELCO P protocol; ID 1 ~ 255 for PELCO D protocol.

PROTOCOL SET:

- Set the mode to **AUTO**, **NATIVE**, **PELCO** or **LG**.
- Camera automatically detects the type of PELCO Protocol. No extra settings are required to set D and P Protocols.

SPEED SET:

- Set the speed to 2400, 4800, 9600 or 19200.

PARITY SET:

- Set the parity to **NONE**, **ODD**, or **EVEN**.

INITIAL SET

- Set the initial set mode to **ON**, All functions are changed to the factory setting, excluding communication function.

EXIT

- Exit the OSD menu and enter the normal display.
- Letters in **BOLD**: Default Mode.

9. Camera Control Command Protocol

(For RS-232, RS-422, and RS-485)

9.1 Communication Format

The communication data format from PC to Camera

Data of total 6 bytes is transmitted from PC to camera.

Format:

Byte1	Byte2	Byte3	Byte4	Byte5	Byte6
0xC5	Code1	Code2	Code3	CAM_ID	C.S.

Description: (Refer to 9.2 PC Command)

- (a) Byte 1: Camera realizes the protocol comes from the PC.
- (b) Byte 2: The data is changeable according to the PC Command.
- (c) Byte 3: The data is changeable according to the PC Command.
- (d) Byte 4: The data is changeable according to the PC Command.
- (e) Byte 5: Camera's ID (Identification) number to communicate (0 ~ 255).

It will be impossible to communicate when there's a difference between the value of CAM_ID and the given value of the Camera's ID.

- (f) Byte 6: The value of Check Sum from 'Byte 1' to 'Byte 5'.

Ex.: In case of transmission, '0xC5, 0x5F, 0x0C, 0x00, 0x00'

$$0xC5 + 0x5F + 0x0C + 0x00 + 0x00 = 0x130$$

Therefore, C.S. = 0x30

The communication data format from Camera to PC

Data of total 9 bytes is transmitted from Camera to PC.

Format:

Byte1	Byte2	Byte3	Byte4	Byte5	Byte6	Byte7	Byte8	Byte9
0xC5	Code1	Code2	Code3	Data1	Data2	Data3	Data4	C.S.

Description: (Refer to 9.2 PC Command)

- (a) Byte 1: Camera is realized the protocol comes from PC.
- (b) Byte 2: Byte 1 data is received from PC.
- (c) Byte 3: Byte 2 data is received from PC.
- (d) Byte 4: Byte 3 data is received from PC.
- (e) Byte 5: The data is changeable according to the PC Command.
- (f) Byte 6: The data is changeable according to the PC Command.
- (g) Byte 7: The data is changeable according to the PC Command.
- (h) Byte 8: The data is changeable according to the PC Command.
- (i) Byte 9: The value of Check Sum from 'Byte 1' to 'Byte 8'.

The computing method is the same as “Byte6 of the communication from PC to Camera“.

9.2 PC Command

Exposure Mode Setting

Set the mode of Exposure according to AEmodeCNT.

PC → Camera

0xC5 0xAA 0x60 AEmodeCNT CAM_ID C.S.

Camera → PC

0xC5 0xAA 0x60 AEmodeCNT 0x60 0xFF 0xFF 0xFF C.S.

AEmodeCNT: The counter for setting Exposure Mode

1. In case of AEmodeCNT = 0x00, the Exposure Mode becomes “AUTO” mode.
2. In case of AEmodeCNT = 0x01, this value is not used.
3. In case of AEmodeCNT = 0x02, the Exposure Mode becomes “IRIS MAN” mode. And then you can adjust “IRIS level” manually.
4. In case of AEmodeCNT = 0x03, the Exposure Mode becomes “AGC MAN” mode. And you can adjust “AGC level” manually.
5. In case of AEmodeCNT = 0x04, the Exposure Mode becomes “MANUAL” mode. And you can adjust “IRIS level” and “AGC level” manually.
6. In case of AEmodeCNT = every other value, the Exposure Mode remains changed.

BACKLIGHT Level Read

Read the current BACKLIGHT level of Camera.

PC → Camera

0xC5 0xAA 0x61 0x00 CAM_ID C.S.

Camera → PC

0xC5 0xAA 0x61 0x00 BL_level 0xFF 0xFF 0xFF C.S.

BL_level: This is a value of the camera for controlling BACKLIGHT level.

Adjust BACKLIGHT level

Adjust current BACKLIGHT level of Camera.

PC → Camera

0xC5 0xAA 0x62 BL_level CAM_ID C.S.

Camera → PC

0xC5 0xAA 0x62 BL_level 0x62 0xFF 0xFF 0xFF C.S.

BL_level: This is a value to adjust BACKLIGHT level of camera.

White Balance Mode Setting

Set the mode of White Balance according to WB_CNT.

PC → Camera

0xC5 0xAA 0x65 WB_CNT CAM_ID C.S.

Camera → PC

0xC5 0xAA 0x65 WB_CNT 0x65 0xFF 0xFF 0xFF C.S.

WB_CNT: This is an index counter to change the mode of White Balance

1. In case of WB_CNT = 0, the mode of White Balance becomes “AUTO” mode.
2. In case of WB_CNT = 1, the mode of White Balance becomes “HUE” mode.
3. In case of WB_CNT = 2, the mode of White Balance becomes “INDOOR” mode.
4. In case of WB_CNT = 3, the mode of White Balance becomes “OUTDOOR” mode.
5. In case of WB_CNT = 4, the mode of White Balance becomes “MANUAL” mode.
6. In case of WB_CNT = 5, the mode of White Balance becomes “PUSH AUTO” mode.
7. In case of WB_CNT = every other value, the mode of White Balance remains unchanged.

Camera ID Display Mode ON/OFF Toggle control

Switch the display mode of camera ID (ON/OFF).

PC → Camera

0xC5 0xAA 0x6A 0x00 CAM_ID C.S.

Camera → PC

0xC5 0xAA 0x6A 0x00 0x6A 0xXX 0xXX 0xXX C.S.

Caution: If the Camera ID is “OFF” mode, then the Camera ID is not displayed.

Zoom Lens Position Read

Read the current position value of Zoom lens & Digital Zoom MAG data.

PC → Camera

0xC5 0x36 0x00 0x00 CAM_ID C.S.

Camera → PC

0xC5 0x36 0x00 0x00 ZP_CNT+1 ZP_CNT V_MAG 0xXX C.S.

1. ZP_CNT+1: Upper byte of Zoom lens position.
2. ZP_CNT: Lower byte of Zoom lens position.
3. V_MAG: Digital zoom data.

Ex. In case of Zoom lens Position = 0x12A & Digital zoom data = 0x10,

- a. ZP_CNT+1 = 0x01
- b. ZP_CNT = 0x2A
- c. V_MAG = 0x10

Caution: This command is used to set the PRESET mode control.

Focus Lens Position Read

Read the current value of Focus lens.

PC → Camera

0xC5 0x37 0x00 0x00 CAM_ID C.S.

Camera → PC

0xC5 0x37 0x00 0x00 FP_CNT+1 FP_CNT 0xXX 0xXX C.S.

1. FP_CNT+1: Upper byte of Focus lens position.
2. FP_CNT: Lower byte of Focus lens position.

Ex. In case of Focus lens Position = 0x1A2,

- a. FP_CNT+1 = 0x01
- b. FP_CNT = 0xA2

Caution: This command is used to set the PRESET mode.

Camera Power ON

Turn on the power of Camera.

PC → Camera

0xC5 0x3A 0x00 0x00 CAM_ID C.S.

Camera → PC

0xC5 0x3A 0x00 0x00 0x00 0x00 0xXX 0xXX C.S.

Camera Power OFF

Turn off the power of Camera.

PC → Camera

0xC5 0x3E 0x00 0x00 CAM_ID C.S.

Camera → PC

0xC5 0x3E 0x00 0x00 0x00 0x00 0xXX 0xXX C.S.

Memorize Zoom Lens Position for External PRESET control

Memorize the Zoom lens position into the volatile “Buffer RAM” designated “Buffer RAM Index” for the external PRESET Move control.

PC → Camera

0xC5 0x49 PRE_I_ZH ZPL CAM_ID C.S.

Camera → PC

0xC5 0x49 PRE_I_ZH ZPL PRE_I_ZH 0xXX 0xXX 0xXX C.S.

1. PRE_I_ZH: The index value of the Buffer RAM to store the position of the Zoom lens for the PRESET mode, and the upper data of position value for the Zoom lens.

Bit No.	Bit 7	Bit 6	Bit 5	Bit 4	Bit 3	Bit 2	Bit 1	Bit 0
Description	Buffer RAM Index (0 ~ 7)				Upper data of Zoom lens position			

2. ZPL: Lower data of position value for the Zoom lens.

Ex. The position of Zoom Lens to memorize = 0x126 &

The index of Buffer RAM for PRESET = 2

0xC5 0x49 PRE_I_ZH ZPL CAM_ID C.S.

0xC5 0x49 0x21 0x26 CAM_ID C.S.

Memorize Focus Lens Position for External PRESET control

Memorize the Focus lens position into the volatile “Buffer RAM” designated “Buffer RAM Index” for the external PRESET Move control.

PC → Camera

0xC5 0x4A PRE_I_FH FPL CAM_ID C.S.

Camera → PC

0xC5 0x4A PRE_I_FH FPL PRE_I_FH 0xXX 0xXX 0xXX C.S.

1. PRE_I_FH: The index value of Buffer RAM to store the position of the Focus lens for the PRESET mode, and the upper data of position value for the Focus lens.

Bit No.	Bit 7	Bit 6	Bit 5	Bit 4	Bit 3	Bit 2	Bit 1	Bit 0
Description	Buffer RAM Index (0 ~ 7)				Upper data of Focus lens position			

2. FPL: Lower data of position value for the Focus lens.

Ex. Memorize 0x21F to the Focus Lens Position in PRESET 3.

0xC5 0x4A PRE_I_FH FPL CAM_ID C.S.

0xC5 0x4A 0x32 0x1F CAM_ID C.S.

Memorize Digital Zoom Position for External PRESET control

Memorize the Digital Zoom position into the volatile “Buffer RAM” designated “Buffer RAM Index” for the external PRESET Move control.

PC → Camera

0xC5 0x4B PRE_I DZP CAM_ID C.S.

Camera → PC

0xC5 0x4B PRE_I DZP PRE_I 0xXX 0xXX 0xXX C.S.

1. PRE_I: The index value of Buffer RAM to store the position of the Digital Zoom for the PRESET mode.

Bit No.	Bit 7	Bit 6	Bit 5	Bit 4	Bit 3	Bit 2	Bit 1	Bit 0
Description	Buffer RAM Index (0 ~ 7)							

2. DZP: Digital Zoom position.

Ex. Memorize 0x20 to the Digital Zoom Position in PRESET 0.

0xC5 0x4B PRE_I DZP CAM_ID C.S.

0xC5 0x4B 0x00 0x20 CAM_ID C.S.

Non Zoom Tracking External PRESET Move Control

Move the Zoom and Focus lens to each position and set the Digital Zoom ratio according to data memorized in PRESET “Buffer RAM” designated ‘INDEX’.

PC → Camera

0xC5 0x4D INDEX 0x00 CAM_ID C.S.

Camera → PC

0xC5 0x4D INDEX 0x00 INDEX 0xXX 0xXX 0xXX C.S.

INDEX: Position setting index of the PRESET Buffer RAM to change Zoom, Focus & Digital Zoom position.

Caution: The range of INDEX is from 0x00 to 0x07.

Camera RESTART

Restart the Camera’s micro controller (u-COM).

PC → Camera

0xC5 0x4F 0x00 0x00 CAM_ID C.S.

Camera → PC

0xC5 0x4F 0x00 0x00 0x00 0xXX 0xXX 0xXX C.S.

Digital Zoom Power Adjust

Adjust Digital Zoom Max Power.

PC → Camera

0xC5 0x52 INDEX 0x00 CAM_ID C.S.

Camera → PC

0xC5 0x52 INDEX 0x00 INDEX 0xXX 0xXX 0xXX C.S.

INDEX: Index value for setting up Max Power Digital Zoom.

1. In case of INDEX = 0, the Max Power Digital Zoom = 2X. Therefore, Total Zoom = 70X.
2. In case of INDEX = 1, the Max Power Digital Zoom = 3X. Therefore, Total Zoom = 105X.
3. In case of INDEX = 2, the Max Power Digital Zoom = 4X. Therefore, Total Zoom = 140X.
4. In case of INDEX = 3, the Max Power Digital Zoom = 5X. Therefore, Total Zoom = 175X.
5. In case of INDEX = 4, the Max Power Digital Zoom = 6X. Therefore, Total Zoom = 210X.
6. In case of INDEX = 5, the Max Power Digital Zoom = 7X. Therefore, Total Zoom = 245X.
7. In case of INDEX = 6, the Max Power Digital Zoom = 8X. Therefore, Total Zoom = 280X.
8. In case of INDEX = 7, the Max Power Digital Zoom = 9X. Therefore, Total Zoom = 315X.
9. In case of INDEX = 8, the Max Power Digital Zoom = 10X. Therefore, Total Zoom = 350X.
10. In case of INDEX = 9, the Max Power Digital Zoom = 11X. Therefore, Total Zoom = 385X.
11. In case of INDEX = 10, the Max Power Digital Zoom = 12X. Therefore, Total Zoom = 420X.
12. In case of INDEX = 11, the Max Power Digital Zoom = 13X. Therefore, Total Zoom = 455X.
13. In case of INDEX = 12, the Max Power Digital Zoom = 14X. Therefore, Total Zoom = 490X.
14. In case of INDEX = 13, Max Power Digital Zoom = 15X. Therefore, Total Zoom = 525X.
15. In case of INDEX = 14, Max Power Digital Zoom = 16X. Therefore, Total Zoom = 560X.
16. In case of INDEX = every other value, the Max Power Digital Zoom remains unchanged.

Key Action

Perform the Key action according to the data of "KEY_NUM".

Caution: After using the Key action, Camera has to be notified by stop of key action code KEY_NUM = "KN_STOP".

PC → Camera

0xC5 0x5F KEY_NUM 0x00 CAM_ID C.S.

Camera → PC

0xC5 0x5F KEY_NUM 0x00 KEY_NUM 0xXX 0xXX 0xXX C.S.

KEY_NUM: This is a Key code value for operation (Refer to 9.3 Key Code Table).

Changing CAM ID

Change the data of CAM_ID to "NEW_C_ID" and Camera ID mode.

PC → Camera

0xC5 0x78 NEW_C_ID On/Off CAM_ID C.S.

Camera → PC

0xC5 0x78 NEW_C_ID On/Off NEW_C_ID 0xXX 0xXX 0xXX C.S.

1. NEW_C_ID; New data to change Camera ID.
2. On/Off: Setting the Camera ID mode to “On” or “Off”.

If On/Off = “0x00”, the Camera ID mode becomes “OFF” mode. In this case, we may ignore “CAM_ID” value. Otherwise, the Camera ID mode becomes “ON” mode. Then, the value of CAM_ID is changed to “NEW_C_ID”.

CAM ID Read

Read the data of Camera ‘s ID.

Caution: This command may only be used in condition of one by one connection (PC vs. CAMERA).

PC → Camera

0xC5 0xCC 0x00 0x00 CAM_ID C.S.

Camera → PC

0xC5 0xCC 0x00 0x00 CAM_ID On/Off 0xXX 0xXX C.S.

1. CAM_ID; The Camera ID data of a CAMERA.
2. On/Off: The On/Off mode of the camera ID.

0x00: Camera ID is “OFF” mode.

0xFF: Camera ID is “ON” mode.

Auto Back Light Mode ON/OFF control

Change the Auto Back Light Mode of camera.

PC → Camera

0xC5 0xAA 0x6D MODE CAM_ID C.S.

Camera → PC

0xC5 0xAA 0x6D MODE 0x6D 0xXX 0xXX 0xXX C.S.

1. In case of MODE = 0x00, the Auto Back Light Mode of camera becomes OFF mode. In this case, the camera key controls Back Light ON/OFF manually.
2. In case of MODE = 0x01, the Auto Back Light Mode of the camera becomes ON mode. Then, Back Light ON/OFF is controlled automatically depending on the status of the scene.
3. In case of MODE = every other value, the Auto Back Light Mode of camera remains unchanged.

BACKLIGHT ON/OFF control

Switch the BACKLIGHT mode to On/Off according to the data of “MODE”.

PC → Camera

0xC5 0xAA 0x70 MODE CAM_ID C.S.

Camera → PC

0xC5 0xAA 0x70 MODE 0x70 0xFF 0xFF 0xFF C.S.

1. In case of MODE = 0x01, The BACKLIGHT mode becomes ON mode.
2. In case of MODE = 0x00, The BACKLIGHT mode becomes OFF mode. Otherwise, The BACKLIGHT mode is not changed.

Caution: In this case, the Auto Back Light mode is released automatically.

100% NEGATIVE ON/OFF control

Switch the 100% NEGATIVE mode to On/Off according to the data of “MODE”.

PC → Camera

0xC5 0xAA 0x72 MODE CAM_ID C.S.

Camera → PC

0xC5 0xAA 0x72 MODE 0x72 0xFF 0xFF 0xFF C.S.

1. In case of MODE = 0x01, the 100% NEGATIVE mode becomes ON mode.
2. In case of MODE = 0x00, the 100% NEGATIVE mode becomes OFF mode.
3. Otherwise, the 100% NEGATIVE mode remains unchanged.

FOCUS Mode Setting

Switch the FOCUS mode to AUTO, MANUAL or PUSH_AUTO according to the data of “MODE”.

PC → Camera

0xC5 0xAA 0x73 MODE CAM_ID C.S.

Camera → PC

0xC5 0xAA 0x73 MODE 0x73 0xFF 0xFF 0xFF C.S.

1. In case of MODE = 0x00, the FOCUS mode becomes “AUTO” mode.
2. In case of MODE = 0x01, the FOCUS mode becomes “MANUAL” mode.
3. In case of MODE = 0x02, the FOCUS mode becomes “PUSH AUTO” mode.
4. Otherwise, the FOCUS mode remains unchanged.

FLICKERLESS Mode ON/OFF Setting

Switch the FLICKERLESS mode to ON or OFF according to the data of the “MODE”.

PC → Camera

0xC5 0xAA 0x74 MODE CAM_ID C.S.

Camera → PC

0xC5 0xAA 0x74 MODE 0x74 0xFF 0xFF 0xFF C.S.

1. In case of MODE = 0x01, the FLICKERLESS mode becomes “ON” mode.
2. In case of MODE = 0x00, the FLICKERLESS mode becomes “OFF” mode.
3. Otherwise, the FLICKERLESS mode remains unchanged.

Hue White Balance Mode MWB_CTL data Setting

Set the MWB_CTL data at Hue White Balance mode according to the data of “MWB_CTL”.

PC → Camera

0xC5 0xAA 0x77 MWB_CTL CAM_ID C.S.

Camera → PC

0xC5 0xAA 0x77 MWB_CTL 0x77 0xFF 0xFF 0xFF C.S.

MWB_CTL: This is a data for which adjusts a HUE point at the Hue White Balance mode. Data range: 00 ~ 99

White Balance PUSH_AUTO ON/OFF Setting

Switch the PUSH AUTO White Balance state to ON or OFF at PUSH AUTO White Balance mode according to the data of “MODE”.

PC → Camera

0xC5 0xAA 0x78 MODE CAM_ID C.S.

Camera → PC

0xC5 0xAA 0x78 MODE 0x78 0xFF 0xFF 0xFF C.S.

1. If MODE = 0x01, the PUSH AUTO White Balance state becomes to ON. In this case, White Balance Tracking is activated.
2. If MODE = 0x00, the PUSH AUTO White Balance state becomes to OFF. In this case, White Balance Tracking is stopped.

3. Otherwise, the PUSH AUTO White Balance state remains unchanged.

Caution: This mode will not be saved when the power of a camera turns OFF/ON. Default mode is “OFF” mode. This command is valid when the White Balance Mode is “PUSH AUTO” mode.

SHARPNESS Data Setting

Set the sharpness level of the camera according to the data of “Sharpness”.

PC → Camera

0xC5 0xAA 0x79 Sharpness CAM_ID C.S.

Camera → PC

0xC5 0xAA 0x79 Sharpness 0x79 0xFF 0xFF 0xFF C.S.

1. The data for adjusting sharpness level of the camera.
2. Data value range: 0x00 ~ 0x0F

BRIGHTNESS Data Setting

Set the brightness level of the camera according to the data of “Brightness”.

PC → Camera

0xC5 0xAA 0x7A Brightness CAM_ID C.S.

Camera → PC

0xC5 0xAA 0x7A Brightness 0x7A 0xFF 0xFF 0xFF C.S.

Brightness: The data for adjusting the brightness level of the camera.

MENU OSD Display ON/OFF Setting

Set the MENU OSD Display mode of the camera to ON or OFF according to the data of “MODE”.

PC → Camera

0xC5 0xAA 0x63 MODE CAM_ID C.S.

Camera → PC

0xC5 0xAA 0x63 MODE 0x63 0xFF 0xFF 0xFF C.S.

1. In case of MODE = 0x01, “Main Menu” OSD is displayed on the screen.
2. In case of MODE = 0x00, MENU OSD is erased on the screen.
3. Otherwise, no action is performed.

SHUTTER Speed Setting

Set the shutter speed of the camera according to the data of “SSC_CNT”.

PC → Camera

0xC5 0xAA 0x7B SSC_CNT CAM_ID C.S.

Camera → PC

0xC5 0xAA 0x7B SSC_CNT 0x7B 0xFF 0xFF 0xFF C.S.

SSC_CNT	NTSC	PAL	SSC_CNT	NTSC	PAL
0	1/60	1/50	15	1/1100	1/1100
1	1/125	1/125	16	1/1200	1/1200
2	1/150	1/150	17	1/1300	1/1300
3	1/200	1/200	18	1/1500	1/1500
4	1/250	1/250	19	1/1600	1/1600
5	1/300	1/300	20	1/1800	1/1800
6	1/350	1/350	21	1/2000	1/2000
7	1/400	1/400	22	1/2500	1/2500
8	1/450	1/450	23	1/3000	1/3000
9	1/500	1/500	24	1/3500	1/3500
10	1/600	1/600	25	1/4000	1/4000
11	1/700	1/700	26	1/6000	1/6000
12	1/800	1/800	27	1/10000	1/10000
13	1/900	1/900	28	1/30000	1/30000
14	1/1000	1/1000			

IRIS OPEN Level Setting

Set the IRIS OPEN Level of the camera according to the data of “IRIS_CTL”.

PC → Camera

0xC5 0xAA 0x7C IRIS_CTL CAM_ID C.S.

Camera → PC

0xC5 0xAA 0x7C IRIS_CTL 0x7C 0xFF 0xFF 0xFF C.S.

IRIS_CTL: The data for adjusting IRIS level of the camera.

Data value range from 0x4A (Full Close) to 0xB3 (Full Open)

Caution: This Command is valid when the Exposure Mode is “IRIS MAN” or “MANUAL”

AGC Level Setting

Set the AGC Level of the camera according to the data of “AGC_CTL”.

PC → Camera

0xC5 0xAA 0x7D AGC_CTL CAM_ID C.S.

Camera → PC

0xC5 0xAA 0x7D AGC_CTL 0x7D 0xXX 0xXX 0xXX C.S.

AGC_CTL: The data for adjusting the AGC level of the camera.

Data value range from 0x1C (Minimum AGC Level) to 0xDC (Maximum AGC Level)

Caution: This command is valid when the Exposure Mode is “AGC MAN” or “MANUAL”.

Function OSD Display Mode Change

Change the Function OSD Display Mode of the camera according to the data of “OSD_DISP”.

PC → Camera

0xC5 0xAA 0x64 OSD_DISP CAM_ID C.S.

Camera → PC

0xC5 0xAA 0x64 OSD_DISP 0x64 0xXX 0xXX 0xXX C.S.

OSD_DISP

Bit	Explanation
7	Reserved, Fix to “0”.
6	Reserved, Fix to “0”.
5	0: OFF 1: General Function OSD Display ON (Focus Auto/Manual OSD, Back Light OSD, Shutter Speed OSD, White Balance Mode OSD)
4	Reserved, Fix to “0”.
3	0: OFF. 1: Camera ID OSD Display ON.
2	0: OFF. 1: Zoom Magnitude OSD Display ON.
1	0: OFF. 1: User Title OSD Display ON.
0	0: OFF. 1: Power ON Initial Title OSD Display ON.

Digital Zoom Mode ON/OFF Setting

Switch the Digital Zoom mode to ON or OFF according to the data of “MODE”.

PC → Camera

0xC5 0xAA 0x6E MODE CAM_ID C.S.

Camera → PC

0xC5 0xAA 0x6E MODE 0x6E 0xXX 0xXX 0xXX C.S.

1. In case of MODE = 0x01, the Digital Zoom Mode is changed to “ON” mode.
2. In case of MODE = 0x00, the Digital Zoom Mode is changed to “OFF” mode.
3. Otherwise, the Digital Zoom Mode remains unchanged.

SCREEN INVERSION (FULL MIRROR) ON/OFF Setting

Switch the SCREEN INVERSION mode to ON or OFF according to the data of “MODE”.

PC → Camera

0xC5 0xAA 0x7F MODE CAM_ID C.S.

Camera → PC

0xC5 0xAA 0x7F MODE 0x7F 0xXX 0xXX 0xXX C.S.

1. In case of MODE = 0x01, The SCREEN INVERSION Mode is changed to “ON” mode. In this case, The Screen is reversed.
2. In case of MODE = 0x00, The SCREEN INVERSION Mode is changed to “OFF” mode.
3. Otherwise, the SCREEN INVERSION Mode remains unchanged.

Caution: This command is valid when the Digital Zoom Mode is OFF.

Slow Speed Zoom Tracking External PRESET Move Control

Performs Zoom Tracking PRESET action to the targeted zoom position, memorized in the volatile PRESET Buffer RAM indicated by the “INDEX” value. In this case, the Zoom Tracking is performed slowly.

PC → Camera

0xC5 0x7B INDEX 0x00 CAM_ID C.S.

Camera → PC

0xC5 0x7B INDEX 0x00 INDEX 0xXX 0xXX 0xXX C.S.

INDEX: The index value of the PRESET Buffer RAM taking the target Zoom position.

Caution: The range of the INDEX is from 0x00 to 0x07.

High Speed Zoom Tracking External PRESET Move Control

Performs Zoom Tracking PRESET action to the targeted zoom position, memorized in the volatile PRESET Buffer RAM indicated by the “INDEX” value. In this case, the Zoom Tracking is performed quickly.

PC → Camera

0xC5 0x7C INDEX 0x00 CAM_ID C.S.

Camera → PC

0xC5 0x7C INDEX 0x00 INDEX 0xXX 0xXX 0xXX C.S.

INDEX: The index value of the PRESET Buffer RAM taking the target Zoom position.

Caution: The range of INDEX is from 0x00 to 0x07.

Zoom Tracking PRESET status Read

Read the status of the Zoom Tracking PRESET action to judge whether the PRESET action has been completed or performed.

PC → Camera

0xC5 0x7F 0x00 0x00 CAM_ID C.S.

Camera → PC

0xC5 0x7F 0x00 0x00 Status 0xXX 0xXX 0xXX C.S.

1. In case of Status = 0x00, the Zoom Tracking PRESET action is complete.
2. In case of Status = 0x01, the Zoom Tracking PRESET action is currently performing.

CAMERA status Read Command 1

Read the current status of the camera. The data is “CAM_CON1”.

PC → Camera

0xC5 0xAA 0x80 0x00 CAM_ID C.S.

Camera → PC

0xC5 0xAA 0x80 0x00 CAM_CON1 0xXX 0xXX 0xXX C.S.

Construction of CAM_CON1 data

Bit	Explanation
7	0: Focus Auto state. 1: Focus Manual state.
6	0: Camera ID OFF mode. 1: Camera ID ON mode.
5	0: WB Push_Auto OFF state. 1: WB Push_Auto ON state.
4	0: BACKLIGHT OFF state. 1: BACKLIGHT ON state.
3	0: FLICKERLESS OFF state. 1: FLICKERLESS ON state.
2	0: Focus AUTO/MANUAL mode. 1: Focus PUSH_AUTO mode.
1	0: Digital Zoom OFF mode. 1: Digital Zoom ON mode.
0	Reserved.

CAMERA status Read Command 2

Read the current status of the camera. The data is “CAM_CON2”.

PC → Camera

0xC5 0xAA 0x81 0x00 CAM_ID C.S.

Camera → PC

0xC5 0xAA 0x81 0x00 CAM_CON2 0xFF 0xFF 0xFF C.S.

Construction of CAM_CON2 data

Bit	Explanation
7	1: Indicating that the camera recheck the object distance for Zoom Tracking.
6	Reserved.
5	Reserved.
4	Reserved.
3	Reserved.
2	Reserved.
1	Reserved.
0	0: Auto BACKLIGHT Mode OFF state. 1: Auto BACKLIGHT Mode ON state.

Digital Effect status of the Camera Read Command

Read the current Digital Effect status of the camera. The data is “DEFT_CON”.

PC → Camera

0xC5 0xAA 0x82 0x00 CAM_ID C.S.

Camera → PC

0xC5 0xAA 0x82 0x00 DEFT_CON 0xFF 0xFF 0xFF C.S.

Construction of DEFT_CON data

Bit	Explanation
7	Reserved.
6	0: Mosaic OFF state. 1: Mosaic ON state.
5	0: Color ON state. 1: Color OFF state.
4	Reserved.
3	0: 100% Negative OFF state. 1: 100% Negative ON state.
2	0: Screen Inversion OFF state. 1: Screen Inversion ON state.
1	Reserved.
0	Reserved.

Read the White Balance Mode

Read the current White Balance Mode of the camera. The data is “WB_MODE”.

PC → Camera

0xC5 0xAA 0x83 0x00 CAM_ID C.S.

Camera → PC

0xC5 0xAA 0x83 0x00 WB_MODE 0xFF 0xFF 0xFF C.S.

Explanation of “WB_MODE” data

WB_MODE	Explanation
0x0	AUTO White Balance mode.
0x1	HUE White Balance mode.
0x2	INDOOR White Balance mode.
0x3	OUTDOOR White Balance mode.
0x4	MANUAL White Balance mode.
0x5	PUSH AUTO White Balance mode.

Read the Exposure Mode

Read the current Exposure Mode of the camera. The data is “AE_MODE”.

PC → Camera

0xC5 0xAA 0x84 0x00 CAM_ID C.S.

Camera → PC

0xC5 0xAA 0x84 0x00 AE_MODE 0xFF 0xFF 0xFF C.S.

Explanation of “AE_MODE” data

AE_MODE	Explanation
0x0	AUTO Exposure mode.
0x2	IRIS MAN Exposure mode.
0x3	AGC MAN Exposure mode.
0x4	MANUAL Exposure mode.

Read the current MWB_CTL data at the Hue White Balance Mode

Read the current HUE point adjust data of the Camera at the Hue White Balance Mode.

The return data is “MWB_CTL”.

PC → Camera

0xC5 0xAA 0x87 0x00 CAM_ID C.S.

Camera → PC

0xC5 0xAA 0x87 0x00 MWB_CTL 0xFF 0xFF 0xFF C.S.

Read the current SHARPNESS data

Read the current SHARPNESS data of the camera. The data is “Sharpness”.

PC → Camera

0xC5 0xAA 0x88 0x00 CAM_ID C.S.

Camera → PC

0xC5 0xAA 0x88 0x00 Sharpness 0xFF 0xFF 0xFF C.S.

Read the current BRIGHTNESS data

Read the current BRIGHTNESS data of the camera. The data is “Brightness”.

PC → Camera

0xC5 0xAA 0x89 0x00 CAM_ID C.S.

Camera → PC

0xC5 0xAA 0x89 0x00 Brightness 0xFF 0xFF 0xFF C.S.

Read the current Shutter Speed Control counter value

Read the current counter value to control Shutter Speed. The data is “SSC_CNT”.

PC → Camera

0xC5 0xAA 0x8A 0x00 CAM_ID C.S.

Camera → PC

0xC5 0xAA 0x8A 0x00 SSC_CNT 0xFF 0xFF 0xFF C.S.

Read the IRIS control data

Read the current IRIS control value to control IRIS OPEN level. The data is “IRIS_CTL”.

PC → Camera

0xC5 0xAA 0x8B 0x00 CAM_ID C.S.

Camera → PC

0xC5 0xAA 0x8B 0x00 IRIS_CTL 0xFF 0xFF 0xFF C.S.

Read the AGC control data

Read the current AGC control value to control AGC level. The data is “AGC_CTL”.

PC → Camera

0xC5 0xAA 0x8C 0x00 CAM_ID C.S.

Camera → PC

0xC5 0xAA 0x8C 0x00 AGC_CTL 0xFF 0xFF 0xFF C.S.

Read the MENU OSD ON/OFF status

Read the current MENU OSD ON/OFF state of the camera. The data is “M_STATE”.

PC → Camera

0xC5 0xAA 0x8D 0x00 CAM_ID C.S.

Camera → PC

0xC5 0xAA 0x8D 0x00 M_STATE 0xFF 0xFF 0xFF C.S.

1. In case of “M_STATE = 0x00”, the MENU OSD is currently not displayed.
2. In case of “M_STATE = 0x01”, the MENU OSD is currently displayed.

Read the Function OSD Display Mode

Read the current Function OSD Display mode of the camera. The data is “OSD_DISP”.

PC → Camera

0xC5 0xAA 0x8E 0x00 CAM_ID C.S.

Camera → PC

0xC5 0xAA 0x8E 0x00 OSD_DISP 0xFF 0xFF 0xFF C.S.

Read the Digital Zoom Max Power Mode

Read the current Max Power Digital Zoom Mode of the camera. The data is “DZ_MAX”.

PC → Camera

0xC5 0xAA 0x8F 0x00 CAM_ID C.S.

Camera → PC

0xC5 0xAA 0x8F 0x00 DZ_MAX 0xFF 0xFF 0xFF C.S.

Caution: The data of this command is valid only when the Digital Zoom mode is ON.

Explanation of “DZ_MAX” data

DZ_MAX	Explanation
0x2	The current Max Power Digital Zoom of the Camera is “x2”.
0x3	The current Max Power Digital Zoom of the Camera is “x3”.
0x4	The current Max Power Digital Zoom of the Camera is “x4”.
0x5	The current Max Power Digital Zoom of the Camera is “x5”.
0x6	The current Max Power Digital Zoom of the Camera is “x6”.
0x7	The current Max Power Digital Zoom of the Camera is “x7”.
0x8	The current Max Power Digital Zoom of the Camera is “x8”.
0x9	The current Max Power Digital Zoom of the Camera is “x9”.
0xA	The current Max Power Digital Zoom of the Camera is “x10”.
0xB	The current Max Power Digital Zoom of the Camera is “x11”.
0xC	The current Max Power Digital Zoom of the Camera is “x12”.
0xD	The current Max Power Digital Zoom of the Camera is “x13”.
0xE	The current Max Power Digital Zoom of the Camera is “x14”.
0xF	The current Max Power Digital Zoom of the Camera is “x15”.
0x10	The current Max Power Digital Zoom of the Camera is “x16”.

Memorize Internal PRESET Position for Internal PRESET control

Memorize the current zoom, focus, and digital zoom position value into the internal nonvolatile memory of the CAMERA for controlling the Internal PRESET Move. The memory position to store is indicated by the “INDEX” value.

PC → Camera

0xC5 0x79 INDEX 0x00 CAM_ID C.S.

Camera → PC

0xC5 0x79 INDEX 0x00 INDEX 0xFF 0xFF 0xFF C.S.

INDEX: The value for indicating the memory position to store the zoom, focus, and digital zoom position value.

The range of this value is from 0x00 to 0x7F.

Internal Non Zoom Tracking PRESET Moving control

Performs the Internal PRESET Moving action. When the camera receives this command, the zoom, focus, and digital zoom position is moved to the position memorized in the internal nonvolatile memory of the camera according to “INDEX” value.

PC → Camera

0xC5 0x7A INDEX 0x00 CAM_ID C.S.

Camera → PC

0xC5 0x7A INDEX 0x00 INDEX 0xXX 0xXX 0xXX C.S.

INDEX: The value for indicating the memory position to store the zoom, focus, and digital zoom position value.

The range of this value is from 0x00 to 0x7F.

Slow Speed Internal Zoom Tracking PRESET Moving control

Perform the Zoom Tracking PRESET action to the target zoom position slowly. In this case, the target zoom position value is memorized in the internal nonvolatile memory. And, the memory position is indicated by the “INDEX” value

PC → Camera

0xC5 0x7D INDEX 0x00 CAM_ID C.S.

Camera → PC

0xC5 0x7D INDEX 0x00 INDEX 0xXX 0xXX 0xXX C.S.

INDEX: This is a value for indicating the memory position to store the zoom, focus, and digital zoom position value.

The range of this value is from 0x00 to 0x7F.

High Speed Internal Zoom Tracking PRESET Moving control

Performs the Zoom Tracking PRESET action to the target zoom position quickly. In this case, the target zoom position value is memorized in the internal nonvolatile memory. And, the memory position is indicated by the “INDEX” value

PC → Camera

0xC5 0x7E INDEX 0x00 CAM_ID C.S.

Camera → PC

0xC5 0x7E INDEX 0x00 INDEX 0xXX 0xXX 0xXX C.S.

INDEX: The value for indicating the memory position to store the zoom, focus, and digital zoom position value.

The range of this value is from 0x00 to 0x7F.

Focusing Object Distance Setting

Set the object distance range.

PC → Camera

0xC5 0x58 Distance 0x00 CAM_ID C.S.

Camera → PC

0xC5 0x58 Distance 0x00 Distance 0xXX 0xXX 0xXX C.S.

Distance: The value for indicating the object distance range limit that the camera can be focused.

1. In case of “0x00”: Focusing range = From 1 cm To infinite
2. In case of “0x01”: Focusing range = From 10 cm To infinite
3. In case of “0x02”: Focusing range = From 50 cm To infinite
4. In case of “0x03”: Focusing range = From 1 m To infinite
5. In case of “0x04”: Focusing range = From 3 m To infinite
6. In case of “0x05”: Focusing range = From 5 m To infinite
7. In case of “0x06”: Focusing range = From 10 m To infinite
8. In case of every other value: The focusing range remains unchanged.

Focus Lens FAR Direction Step Move Command

This command moves the focus lens by a specific step number in the direction of FAR.

Caution: This command is performed, when the focus mode is MANUAL or PUSH_AUTO. And is not performed during Zooming.

PC → Camera

0xC5 0xAA 0x5D STEP CAM_ID C.S.

Camera → PC

0xC5 0xAA 0x5D STEP 0x5D 0xXX 0xXX 0xXX C.S.

STEP: The value specifying the number step to move the focus lens in the direction of FAR.

Focus Lens NEAR Direction Step Move Command

This Command moves the focus lens by a specific number step in the direction of NEAR.

Caution: This command is performed, when the focus mode is MANUAL or PUSH_AUTO. And is not performed during Zooming.

PC → Camera

0xC5 0xAA 0x5E STEP CAM_ID C.S.

Camera → PC

0xC5 0xAA 0x5E STEP 0x5E 0xXX 0xXX 0xXX C.S.

STEP: The value specifying the step number to move the focus lens in the direction of NEAR.

MENU OSD Display On/Off Command

This Command decides whether or not the MENU OSD is to be displayed on the screen according to “INDEX”.

PC → Camera

0xC5 0xAA 0x6F INDEX CAM_ID C.S.

Camera → PC

0xC5 0xAA 0x6F INDEX 0x6F 0xXX 0xXX 0xXX C.S.

INDEX: The value, which selects the MENU OSD page or erases the MENU OSD on the screen.

1. In case of INDEX = 0x00, the “Main Menu” OSD is displayed.
2. In case of INDEX = 0x01, the “Focus Sub Menu” OSD is displayed.
3. In case of INDEX = 0x02, the “White Balance Sub Menu” OSD is displayed.
4. In case of INDEX = 0x03, the “Exposure Sub Menu” OSD is displayed.
5. In case of INDEX = 0x04, the “Special Function Sub Menu” OSD is displayed.
6. In case of INDEX = 0x06, the “Function OSD Sub Menu” OSD is displayed.
7. In case of INDEX = 0x05 or > 0x06, the Menu OSD is erased.

Camera ID Function OSD Display Mode On/Off Setting Command

This Command decides whether or not the Camera ID Function OSD is to be displayed on the screen.

PC → Camera

0xC5 0xAA 0x96 OnOff CAM_ID C.S.

Camera → PC

0xC5 0xAA 0x96 OnOff 0x96 0xXX 0xXX 0xXX C.S.

1. In case of INDEX = 0x00, the Camera ID Function OSD is not displayed.
2. In case of INDEX = 0x01, the Camera ID Function OSD is displayed.
3. In case of INDEX = every other value, No action is performed.

Each Sub Menu Items Initialization Command.

This Command initializes all data of each sub menu.

PC → Camera

0xC5 0xAA 0x97 INDEX CAM_ID C.S.

Camera → PC

0xC5 0xAA 0x97 INDEX 0x97 0xXX 0xXX 0xXX C.S.

INDEX: This is a value, which selects the sub MENU.

1. In case of INDEX = 0x00, the data of all Sub Menu are initialized.
2. In case of INDEX = 0x01, the data of “Focus Sub Menu” are initialized.
3. In case of INDEX = 0x02, the data of “White Balance Sub Menu” is initialized.
4. In case of INDEX = 0x03, the data of “Exposure Sub Menu” is initialized.
5. In case of INDEX = 0x04, the data of “Special Function Sub Menu” is initialized.
6. In case of INDEX = 0x06, the data of “Function OSD Sub Menu” is initialized.

Camera Control Status Register 3 Data Read Command

Read the status that the camera is controlled.

PC → Camera

0xC5 0xAA 0x9A 0x00 CAM_ID C.S.

Camera → PC

0xC5 0xAA 0x9A 0x00 CAM_CON3 0xXX 0xXX 0xXX C.S.

CAM_CON3: This is a status value that the camera is currently controlled.

Bit	Explanation
7	1: High Speed Zoom Tracking Mode
6	1: Normal Speed Zoom Tracking Mode
5	1: Auto Focus Zoom Tracking Mode at MANUAL or PUSH_AUTO Focus mode
4	Reserved.
3	0: Wide Burst Function OFF mode. 1: Wide Burst Function ON mode.
2	Reserved.
1	Reserved.
0	Reserved.

Zoom Tracking Mode Change Command

This command changes the zoom tracking mode according to MODE.

PC → Camera

0xC5 0xAA 0x9B MODE CAM_ID C.S.

Camera → PC

0xC5 0xAA 0x9B MODE 0x9B 0xFF 0xFF 0xFF C.S.

1. In case of MODE = 0x00, the zoom tracking mode becomes MANUAL mode.
2. In case of MODE = 0x01, the zoom tracking mode becomes AUTO FOCUS mode.
3. In case of MODE = every other value, the zoom tracking mode is not changed.

Caution: This command is valid when the focus mode is “MANUAL” or “PUSH AUTO” mode.

Back Light Control Mode Setting Command

This command sets the back light mode of the camera according to MODE.

PC → Camera

0xC5 0xAA 0x9C MODE CAM_ID C.S.

Camera → PC

0xC5 0xAA 0x9C MODE 0x9C 0xFF 0xFF 0xFF C.S.

1. In case of MODE = 0x00, the back light mode becomes OFF mode.
2. In case of MODE = 0x01, the back light mode becomes ON mode.
3. In case of MODE = 0x02, the back light mode becomes AUTO mode.
4. In case of MODE = 0x03, the back light mode becomes SUPER mode.
5. In case of MODE = every other value, the back light mode remains unchanged.

Back Light Control Mode Read Command

This command reads the current back light mode of the camera.

PC → Camera

0xC5 0xAA 0x9D 0x00 CAM_ID C.S.

Camera → PC

0xC5 0xAA 0x9D 0x00 MODE 0xFF 0xFF 0xFF C.S.

1. In case of MODE = 0x00, the current back light mode is OFF mode.
2. In case of MODE = 0x01, the current back light mode is ON mode.
3. In case of MODE = 0x02, the current back light mode is AUTO mode.
4. In case of MODE = 0x03, the current back light mode is SUPER mode.

Wide Burst Function On/Off Control Command

This command controls the wide burst function of the camera according to ONOFF.

PC → Camera

0xC5 0xAA 0x9E ONOFF CAM_ID C.S.

Camera → PC

0xC5 0xAA 0x9E ONOFF 0x9E 0xFF 0xFF 0xFF C.S.

1. In case of ONOFF = 0x00, the wide burst function becomes OFF mode.
2. In case of ONOFF = 0x01, the wide burst function becomes ON mode.
3. In case of ONOFF = every other value, the wide burst function mode remains unchanged.

Red Control Gain Adjust Command

This command adjusts the red control gain of the camera.

PC → Camera

0xC5 0xAA 0xA4 R_Cont CAM_ID C.S.

Camera → PC

0xC5 0xAA 0xA4 R_Cont 0xA4 0xFF 0xFF 0xFF C.S.

R_Cont: The value, which adjusts the red control gain of the camera.

Red Control Gain Read Command

This command reads the current red gain of the camera.

PC → Camera

0xC5 0xAA 0xA5 0x00 CAM_ID C.S.

Camera → PC

0xC5 0xAA 0xA5 0x00 R_Cont 0xFF 0xFF 0xFF C.S.

R_Cont: The value, which is currently assigned to the red control gain of the camera. There is some tolerance between read value and adjust value.

Blue Control Gain Adjust Command

This command adjusts the blue control gain of the camera.

PC → Camera

0xC5 0xAA 0xA6 B_Cont CAM_ID C.S.

Camera → PC

0xC5 0xAA 0xA6 B_Cont 0xA6 0xFF 0xFF 0xFF C.S.

B_Cont: The value, which adjusts the blue control gain of the camera.

Blue Control Gain Read Command

This command reads the current blue gain of the camera.

PC → Camera

0xC5 0xAA 0xA7 0x00 CAM_ID C.S.

Camera → PC

0xC5 0xAA 0xA7 0x00 B_Cont 0xFF 0xFF 0xFF C.S.

B_Cont: The value, which is currently assigned to the blue control gain of the camera. There is some tolerance between read value and adjust value.

MOSAIC Digital Effect On/Off control Command

This command switches the MOSAIC digital effect mode to ON or OFF according to ONOFF.

PC → Camera

0xC5 0xAA 0xA8 ONOFF CAM_ID C.S.

Camera → PC

0xC5 0xAA 0xA8 ONOFF 0xA8 0xFF 0xFF 0xFF C.S.

1. In case of ONOFF = 0x00, the MOSAIC digital effect mode becomes OFF mode.
2. In case of ONOFF = 0x01, the MOSAIC digital effect mode becomes ON mode.
3. In case of ONOFF = every other value, the MOSAIC digital effect mode remains unchanged.

The Object Distance Range Data Read Command

This command reads the object distance range data assigned the camera.

PC → Camera

0xC5 0x59 0x00 0x00 CAM_ID C.S.

Camera → PC

0xC5 0x59 0x00 0x00 Distance 0xFF 0xFF 0xFF C.S.

Distance: The index value, which indicates the current object distance range that the camera can be focused.

1. In case of Distance = “0x00”, the Focusing range = From 1 cm To infinite
2. In case of Distance = “0x01”, the Focusing range = From 10 cm To infinite
3. In case of Distance = “0x02”, the Focusing range = From 50 cm To infinite
4. In case of Distance = “0x03”, the Focusing range = From 1 m To infinite
5. In case of Distance = “0x04”, the Focusing range = From 3 m To infinite
6. In case of Distance = “0x05”, the Focusing range = From 5 m To infinite
7. In case of Distance = “0x06”, the Focusing range = From 10 m To infinite

User Title Display ON Command

This command displays the user title on the screen.

PC → Camera

0xC5 0x67 0x00 0x00 CAM_ID C.S.

Camera → PC

0xC5 0x67 0x00 0x00 0x00 0xXX 0xXX 0xXX C.S.

User Title Display OFF Command

This command does not display the user title on the screen.

PC → Camera

0xC5 0x68 0x00 0x00 CAM_ID C.S.

Camera → PC

0xC5 0x68 0x00 0x00 0x00 0xXX 0xXX 0xXX C.S.

User Title String Editing Command

This command edits the user title string.

PC → Camera

0xC5 0x66 INDEX CHAR CAM_ID C.S.

Camera → PC

0xC5 0x66 INDEX CHAR INDEX 0xXX 0xXX 0xXX C.S.

1. INDEX: The index value, which indicates the character position of the user title string in order to edit. The range of this value is from 0x00 to 0x09.
2. CHAR: The code value in order to edit the character pointed by “INDEX”

CHAR	Character	CHAR	Character	CHAR	Character
0x00	'A'	0x1A	'a'	0x34	'0'
0x01	'B'	0x1B	'b'	0x35	'1'
0x02	'C'	0x1C	'c'	0x36	'2'
0x03	'D'	0x1D	'd'	0x37	'3'
0x04	'E'	0x1E	'e'	0x38	'4'
0x05	'F'	0x1F	'f'	0x39	'5'
0x06	'G'	0x20	'g'	0x3A	'6'
0x07	'H'	0x21	'h'	0x3B	'7'
0x08	'I'	0x22	'i'	0x3C	'8'
0x09	'J'	0x23	'j'	0x3D	'9'
0x0A	'K'	0x24	'k'	0x3E	','
0x0B	'L'	0x25	'l'	0x3F	','
0x0C	'M'	0x26	'm'	0x40	','
0x0D	'N'	0x27	'n'	0x41	'?'
0x0E	'O'	0x28	'o'	0x42	'←'
0x0F	'P'	0x29	'p'	0x43	'→'
0x10	'Q'	0x2A	'q'	0x44	'×
0x11	'R'	0x2B	'r'	0x45	','
0x12	'S'	0x2C	's'	0x46	'◁'
0x13	'T'	0x2D	't'	0x47	'▷'
0x14	'U'	0x2E	'u'	0x48	'<'
0x15	'V'	0x2F	'v'	0x49	'>'
0x16	'W'	0x30	'w'	0x4A	'/'
0x17	'X'	0x31	'x'	0x4B	'*'
0x18	'Y'	0x32	'y'	0x4C	'-'
0x19	'Z'	0x33	'z'	0x4D	Blank

Function OSD Display On/Off Setting Command

This command indicates whether each function OSD of the camera is displayed on the screen.

PC → Camera

0xC5 0x6B INDEX ONOFF CAM_ID C.S.

Camera → PC

0xC5 0x6B INDEX ONOFF INDEX 0xXX 0xXX 0xXX C.S.

INDEX: The index value to select whether or not to display the function OSD.

ONOFF: The value, which indicates whether the selected function OSD is or not displayed.

1. In case of ONOFF = 0x00, the selected function OSD is not displayed on the screen.
2. In case of ONOFF = 0x01, the selected function OSD is displayed on the screen.
3. In case of every other value, the display status of the selected function OSD remains unchanged.

Index	Explanation
0x00	Select the general function OSD.
0x01	Reserved.
0x02	Select the function OSD that is related to the Camera ID.
0x03	Select the function OSD that is related to the Zoom Magnitude.
0x04	Select the function OSD that is related to the User Title.
0x05	Select the function OSD that is related to the Power On Initial Title.

Dark Fade ON (Video Mute) Command

This command mutes the video signal out.

PC → Camera

0xC5 0xAA 0x54 0x00 CAM_ID C.S.

Camera → PC

0xC5 0xAA 0x54 0x00 0x54 0xFF 0xFF 0xFF C.S.

Dark Fade OFF (Video Mute Release) Command

This command releases the video signal, which is muted.

PC → Camera

0xC5 0xAA 0x55 0x00 CAM_ID C.S.

Camera → PC

0xC5 0xAA 0x55 0x00 0x55 0xFF 0xFF 0xFF C.S.

Set Day & Night Control Mode

This command is to set the camera's Day & Night control mode.

PC → Camera

0xC5 0x77 Day_&_Night_Mode 0x00 CAM_ID C.S.

Camera → PC

0xC5 0x77 Day_&_Night_Mode 0x00 Day_&_Night_Mode 0xFF 0xFF 0xFF C.S.

Day & Night Mode	Explanation
0x00	Camera's Day & Night Control Mode becomes "Night Mode".
0x01	Camera's Day & Night Control Mode becomes "Day Mode".
0x02	Camera's Day & Night Control Mode becomes "AE Mode". Camera toggle Day or Night Mode according to exposure of object.
0x03	Camera's Day & Night Control Mode becomes "SENSOR Mode". Camera toggle Day or Night Mode according to sensitivity of SENSOR.
0x04	Camera's Day & Night Control Mode becomes "External Mode".
Other Values	No Operation

Read Day & Night Control Mode

This command is to see the camera's Day & Night control mode.

PC → Camera

0xC5 0xAA 0x81 0x00 CAM_ID C.S.

Camera → PC

0xC5 0xAA 0x81 0x00 Status 0xXX 0xXX 0xXX C.S.

The status of Camera operation: Bit5 & Bit4 are the flags of Day & Night Control Mode

Status		Explanation
Bit5	Bit4	
0	0	Camera's Day & Night Control Mode is "Day & Night DAY Mode".
0	1	Camera's Day & Night Control Mode is "Day & Night NIGHT Mode".
1	0	Camera's Day & Night Control Mode is "Day & Night AUTO Mode" and the status of Camera's Day & Night Control is "Day Mode".
1	1	Camera's Day & Night Control Mode is "Day & Night AUTO Mode" and the status of Camera's Day & Night Control is "Night Mode".

Set Day & Night Data

This command is to set the camera's Day & Night data.

PC → Camera

0xC5 0xF0 Day_&_Night_Index Data CAM_ID C.S.

Camera → PC

0xC5 0xF0 Day_&_Night_Index Data Day_&_Night_Index 0xXX 0xXX 0xXX C.S.

Day & Night Index	Data	Explanation
0x00	SENSOR LEVEL	The SENSOR level is setting up threshold for turning the filter according to sensitivity of SENSOR.
0x01	FILTER DELAY	Delay time for turning the filter
Other Values	No Operation	

Read Day & Night Data

This command is to see the camera's Day & Night data.

PC → Camera

0xC5 0xF0 Day_&_Night_Index 0x00 CAM_ID C.S.

Camera → PC

0xC5 0xF0 Day_&_Night_Index 0x00 Data 0xXX 0xXX 0xXX C.S.

Day & Night Index	Data	Explanation
0x00	SENSOR LEVEL	The SENSOR level is setting up threshold for turning the filter according to sensitivity of SENSOR.
0x01	FILTER DELAY	Delay time for turning the filter
Other Values	No Operation	

9.3 Key Code Table

Key Variable	Key Code	Description
KN_NOT	0x00	No key function will operate.
KN_TELE	0x01	Perform Zoom Tracking to TELE side by slow speed. In case of displaying the MENU, it operates as the "MENU selection scroll up".
KN_HTELE	0x02	Perform Zoom Tracking to TELE side by high speed. In case of displaying the MENU, it operates as the "MENU selection scroll up".
KN_WIDE	0x03	Perform Zoom Tracking to WIDE side by slow speed. In case of displaying the MENU, it operates as the "MENU selection scroll down".
KN_HWIDE	0x04	Perform Zoom Tracking to WIDE side by high speed. In case of displaying the MENU, it operates as the "MENU selection scroll down".
KN_FAR	0x08	In the manual focus mode, move the Focus lens to "FAR" side quickly. In case of displaying the MENU, it operates as the "Decrease the data of a selected item on the MENU".
KN_NEAR	0x09	In the manual focus mode, move the Focus lens to "NEAR" side quickly. In case of displaying the MENU, it operates as the "Increase the data of a selected item on the MENU".
KN_SFAR	0x0A	In the manual focus mode, move the Focus lens to "FAR" side by 1 step. In case of displaying the MENU, it operates as the "Decrease the data of a selected item on the MENU".
KN_SNEAR	0x0B	In the manual focus mode, move the Focus lens to "NEAR" side by 1 step. In case of displaying the MENU, it operates as the "Increase the data of a selected item on the MENU".
KN_STOP	0x0C	Stop all key actions that are being performed currently. After using the key action, the camera has to be notified by the stop of key action.
KN_BL	0x1A	Switch the BACKLIGHT mode (ON / OFF).
KN_FLICKER	0x1B	Switch the FLICKERLESS mode (ON / OFF).
KN_NEGA	0x1E	Switch the NEGATIVE mode (Negative / Positive).
KN_DZOOM	0x22	Switch the Digital Zoom mode (ON / OFF).
KN_OSD	0x24	Switch the Key function OSD (ON / OFF).
KN_MENU	0x25	Switch the main MENU (ON / OFF).
KN_M_UP	0x27	Increase the data of a selected item on the main MENU.
KN_M_DN	0x28	Decrease the data of a selected item on the main MENU.
KN_POWER	0x32	Switch the power of the Camera (ON / OFF).
KN_R_FAR	0x38	In the manual focus mode, move the Focus lens to "FAR" side slowly. In case of displaying the MENU, it operates as the "Decrease the data of selected item in MENU".

KN_R_NEAR	0x39	In the manual focus mode, move the Focus lens to "NEAR" side slowly. In case of displaying the MENU, it operates as the "Increase the data of selected item in MENU".
KN_AM_P	0x3F	According to Key selection mode, operate the key such as "AUTO/MANUAL Toggle" or "Push AUTO".
KN_RS_SSCup	0x40	Use for RS-232C Serial Communication: Scroll up the "Shutter Speed".
KN_RS_SSCdn	0x41	Use for RS-232C Serial Communication: Scroll down the "Shutter Speed".
KN_RS_IRISup	0x42	Use for RS-232C Serial Communication: Scroll up the Iris level of lens. The AE mode must be "IRIS MAN", or "MANUAL".
KN_RS_IRISdn	0x43	Use for RS-232C Serial Communication: Scroll down the Iris level of lens. The AE mode must be "IRIS MAN", or "MANUAL".
KN_RS_AGCup	0x44	Use for RS-232C Serial Communication: Scroll up the AGC level. The AE mode must be "AGC MAN", or "MANUAL".
KN_RS_AGCdn	0x45	Use for RS-232C Serial Communication: Scroll down the AGC level. The AE mode must be "AGC MAN", or "MANUAL".
KN_RS_BRTup	0x46	Use for RS-232C Serial Communication: Scroll up the Brightness level. The AE mode must be "AUTO", "IRIS MAN", or "AGC MAN".
KN_RS_BRTdn	0x47	Use for RS-232C Serial Communication: Scroll down the Brightness level. The AE mode must be "AUTO", "IRIS MAN", or "AGC MAN".
KN_RS_HUEup	0x4C	Use for RS-232C Serial Communication: Scroll up the HUE level in Hue White Balance mode.
KN_RS_HUEdn	0x4D	Use for RS-232C Serial Communication: Scroll down the HUE level in Hue White Balance mode.
KN_RS_WB_PUSH	0x4E	Use for RS-232C Serial Communication: Switch the Push White Balance ON or OFF in Push White Balance mode.
KN_RS_MITEM_UP	0x4F	Use for RS-232C Serial Communication: In case of displaying the MENU. Scroll up the MENU item.
KN_RS_MITEM_DN	0x50	Use for RS-232C Serial Communication: In case of displaying the MENU. Scroll down the MENU item.
KN_RS_AMkey_SET	0x51	Use for RS-232C Serial Communication: Switch the Focus mode "AUTO/MANUAL", or "Push AUTO".
KN_RS_INIT_SET	0x52	Use for RS-232C Serial Communication: Reset the Camera mode to default value.
KN_RS_SRPup	0x53	Use for RS-232C Serial Communication: Scroll up the Sharpness level.
KN_RS_SRPdn	0x54	Use for RS-232C Serial Communication: Scroll up the Sharpness level.
KN_Day_Mode_Control	0x93	Set the "Day & Night DAY Mode"
KN_Night_Mode_Control	0x94	Set the "Day & Night NIGHT Mode"
KN_DayNight_Mode_Control	0x95	Toggle "Day & Night Control Mode" of camera "AE Mode" → "SENSOR Mode" → "Day Mode" → "Night Mode" → "External Mode"

10. SPECIFICATIONS

Image Device:	Sony 1/4" Colour Ex View CCD
Total Pixels No.:	795 (H) x 596 (V) 470K
Effective Pixels No.:	752 (H) x 582 (V) 440K
Resolution:	550 TVL
S/N Ratio:	More than 48 dB
Lens Information:	3.6 to 126.0mm, Auto Iris, 35x Optical Zoom
Min. Shooting Distance:	0.01m (WIDE), 1.5m (TELE)
Minimum Illumination:	0.01 Lux (0 Lux with IR)
Digital Zoom Ratio:	Basic x 16 (Total Zoom Ratio x560), x2 ~ x16 Variable
Sync. System:	Internal
On Screen Display:	OSD On (Menu, Zoom, Focus, WBC, BLC, Shutter, CAM ID, User Title) / Off
Video Output:	Composite Video 1 Vp-p, 75 Ohms, BNC
Audio output:	2 Vp-p, 50 Ohms
Camera Control:	Optional: RS-422/RS-485 or RS-232 (2.4K/4.8K/9.6K/19.2K BPS)
Protocol:	AUTO/ NATIVE/ PELCO/ LG
Zoom Speed:	8 Sec Mode / 11 Sec Mode / 14 Sec Mode
Focus Mode:	Auto / Manual / Push Auto
Brightness Control:	Manual (Brightness Up / Down)
White Balance:	Auto / Hue / Indoor / Outdoor / Manual / Push Auto
Iris Control:	Auto / Manual (Iris Up / Down)
AGC Control:	Auto / Manual (1 dB ~ 26 dB Control)
Day / Night Mode:	AE / SENSOR / Day / Night / External
Shutter Speed:	1/50 ~ 1/30,000 Sec 29 Steps
Flickerless Mode:	Off / On (1/120 Sec Shutter Set)
Back Light Comp.:	On / Auto (Center / Up / Down / Left / Right) / Super / Off
Negative / Positive:	Negative On / Off
Wide Burst:	On / Off
Zoom / Focus Preset:	128 Presets (Store with Internal EEPROM)
Remote Control:	6 Pin Circular Connector: Zoom, Focus, A/D Key, DC12V IN
Key Control:	Tele (Up), Wide (Down), Near (+), Far (-), Menu
Day / Night Control:	Day/Night Output, Day/ Night External Input
Operating Temperature:	-10°C to 50°C
Operating Humidity:	0 % RH ~ 60 % RH
Supplied Voltage:	DC 12 V ±10% (Recommendation DC 12V ±0.5 V)
Power Consumption:	Max 4.1W
Dimensions:	60 x 50 x 130mm (WxHxD)

* Letters in **BOLD**: Default Mode

Note: Design and specifications are subject to change without prior notice.

ACCESSORIES



IR Remote Keyboard Controller - Model: XSD1DCIR

The Xvision XSD1DCIR is an IR Remote Control and transmitter set. The transmitter simply connects to the Zoom camera and then the IR Remote Control can be used to control the Zoom, Focus and Menu of the camera.



Wall/Ceiling camera mounting bracket - Model: WH160

The Xvision WH160 bracket allows you to fix industry standard CCTV cameras to a wall or ceiling.



Weatherproof housing and wall bracket - Model: HCW200

The Xvision HCW200 weatherproof housing and bracket allows external wall mounting of industry standard CCTV cameras in temperatures from -10° to 40°C.



Weatherproof housing and ceiling bracket - Model: HCW200CB

The Xvision HCW200CB weatherproof housing and bracket allows external ceiling mounting of industry standard CCTV cameras in temperatures from -10° to 40°C.



Professional weatherproof housing and wall bracket with built in Heater and Fan, Cable Managed - Model: HCW300

The Xvision HCW300 allows industry standard CCTV cameras to be wall mounted externally in temperatures from -20° to 50°C. The built in fan and heater maintain a temperature of 25°C inside the housing, and to protect the camera cabling the bracket features cable management so no cables are exposed.



Professional weatherproof IR LED housing and wall bracket with built in Heater and Fan, Cable Managed - Model: HCW300IR

The Xvision HCW300IR allows traditional cameras to be wall mounted externally in temperatures from -20 to 50°C. The integrated IR LEDs allow for up to 30 metres Nightvision. The built in fan and heater maintain a temperature of 25°C inside the housing, and to protect the camera cabling the bracket features cable management so no cables are exposed.

NOTES

NOTES

TECHNICAL SUPPORT:

For Technical Support for any Xvision product please contact your local distributor.

LIMITED WARRANTY:

This product is supplied with a limited 3 Year warranty. The Warranty excludes products that have been misused, (including accidental damage) and damage caused by normal wear and tear. In the unlikely event that you encounter a problem with this product, it should be returned to the place of purchase.



Manufactured exclusively for:
Xvision (Europe) Group,
Head Office: London, U.K.
Email: info@x-vision.co.uk
Web: www.x-vision.co.uk