

LVD TEST REPORT

Page 1 of 80

APPLICATION FOR LOW VOLTAGE DIRECTIVE

On Behalf of

MPP SOLAR INC

Charger/ Inverter

Model Number: PIP 2424HS

Prepare for : MPP Solar Inc

Address : 4F, No. 50-1, Section 1, Hsin-Sheng S. Rd. Taipei, Taiwan

Prepare by : MPP Solar Inc

Address : 4F, No. 50-1, Section 1, Hsin-Sheng S. Rd. Taipei, Taiwan

Date of Test: Aug. 24, 2012 to Oct. 17, 2012

Date of Report: Nov. 08, 2012

LVD TEST REPORT

List of Attachments (including a total number of pages in each attachment):

Appendix 1: Photo documentation (9 page)

Appendix 1: Transformer Specification (6 page)

Summary of testing:

The equipment have tested and evaluated to comply with standard

EN 60950-1:2006+A11:2009+A1:2010+A12:2011

Tests performed (name of test and test clause):

-EN 60950-1:2006+A11:2009+A1:2010+A12:2011

Testing location:

4F, No. 50-1, Section 1, Hsin-Sheng S. Rd.

Taipei, Taiwan

Summary of compliance with National Differences

List of countries addressed:

The product fulfils the requirements of CENELEC Countries European Group Differences And National Differences

LVD TEST REPORT

Copy of marking plate

INVERTER CHARGER
Model Name: PIP 2424HS
Color: Silver and Black
Operating Temperature Range: 0~ 55°C





92331210100001

Inverter Mode:
Rated Power: 3000VA/2400W
DC Input: 24VDC, 100A
AC Output: 230VAC, 50Hz, 13A, 1Φ

AC Charger Mode:
AC Input: 230VAC, 50Hz, 17.7A, 1Φ
DC Output: 27VDC, 30/20A
AC Output: 230VAC, 50Hz, 13A, 1Φ

Solar Charger Mode:
Rated Current: 50A
System Voltage: 24VDC
Operating Voltage Range: 30~32Vdc
Max. Solar Voltage (VOC): 60VDC

Marking Label On Side Enclosure Visible During Normal Use

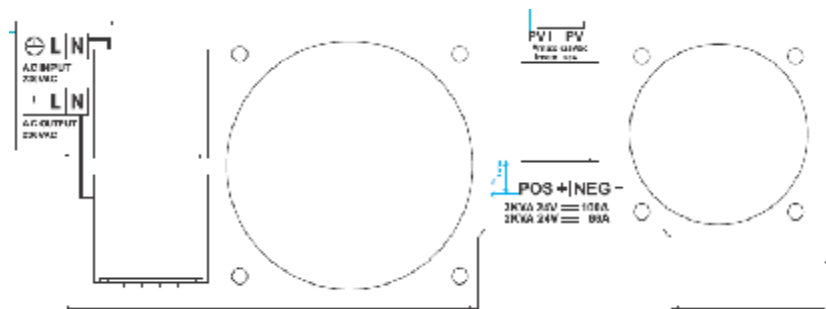

Marking Labels For Input Terminal and Output Terminal Connection Indication Visible during Installation

	CAUTION
	ELECTRIC SHOCK HAZARD ENERGY HAZARDOUS

Warning on Terminals Cover

The above markings are the minimum requirements required by the safety standard. For the final production samples, the additional markings which do not give rise to misunderstanding may be added.

LVD TEST REPORT

Test item particulars :	
Equipment mobility	<input checked="" type="checkbox"/> movable <input type="checkbox"/> hand-held <input type="checkbox"/> transportable <input type="checkbox"/> stationary <input type="checkbox"/> for building-in <input type="checkbox"/> direct plug-in
Connection to the mains	<input type="checkbox"/> pluggable equipment <input type="checkbox"/> type A <input type="checkbox"/> type B <input checked="" type="checkbox"/> permanent connection <input type="checkbox"/> detachable power supply cord <input type="checkbox"/> non-detachable power supply cord <input type="checkbox"/> not directly connected to the mains <input type="checkbox"/> build-in component, consider in end system
Operating condition	<input checked="" type="checkbox"/> continuous <input type="checkbox"/> rated operating / resting time:
Access location	<input checked="" type="checkbox"/> operator accessible <input type="checkbox"/> restricted access location <input type="checkbox"/> build-in component, consider in end system
Over voltage category (OVC)	<input type="checkbox"/> OVC I <input checked="" type="checkbox"/> OVC II <input type="checkbox"/> OVC III <input type="checkbox"/> OVC IV <input type="checkbox"/> other:
Mains supply tolerance (%) or absolute mains supply values	+/- 10%
Tested for IT power systems	<input type="checkbox"/> Yes <input checked="" type="checkbox"/> No
IT testing, phase-phase voltage (V)	
Class of equipment	<input checked="" type="checkbox"/> Class I <input type="checkbox"/> Class II <input type="checkbox"/> Class III <input type="checkbox"/> Not classified
Considered current rating of protective device as part of the building installation (A)	--
Pollution degree (PD)	<input type="checkbox"/> PD 1 <input checked="" type="checkbox"/> PD 2 <input type="checkbox"/> PD 3
IP protection class	IPX0
Altitude during operation (m)	Operated up to 2000m
Altitude of test laboratory (m)	<2000
Mass of equipment (kg)	Max. 6,87 kg
Possible test case verdicts:	
- test case does not apply to the test object.....	N/A (or N)
- test object does meet the requirement.....	P (Pass)
- test object does not meet the requirement	F (Fail)
Testing	
Date of receipt of test item.....	Aug. 24, 2012
Date(s) of performance of tests.....	Aug. 24, 2012 to Oct. 17, 2012

LVD TEST REPORT

General remarks:

The test results presented in this report relate only to the object tested.
This report shall not be reproduced, except in full, without the written approval of the Issuing testing laboratory.

"(see Enclosure #)" refers to additional information appended to the report.

"(see appended table)" refers to a table appended to the report.

When determining the test conclusion, the Measurement Uncertainty of test has been considered.

The observations and test results in this report are relevant only to the sample tested.

The test report only allows to be revised within three years from its original issued date unless further standard or the requirement was noticed.

Throughout this report a comma / point is used as the decimal separator.

Name and address of factory (ies)..... : Same as Applicant.

General product information:

1. The DC input circuit is separated from the AC input and AC output circuit parts by reinforced insulation.
2. The Equipment is an Inverter which is an AC permanent connection with earthing terminal as Class I equipment. It can operate in bypass mode and inverter mode for 230 VAC output supply.
DC batteries can be charged during bypass mode. Inverter mode can be powered by 24 VDC batteries or 125 VDC PV module. Max. unfavorable situations have been considered in this report for compliance.
3. AC Output power factor is $\cos\Phi=0.8$
4. The power supply has been evaluated for use in Pollution Degree 2 environment and operating ambient Max. 55 °C. Max operating temperature 55°C specified in manual. The max. temperature limits are calculated according to $T_{max}' = T_{max} - (55 - T_{amb})$.
5. This Inverter input terminal contains power exceeding 240VA, and AC output is live part. Care must be taken and associated wire(s) may not be touched.
6. No overcurrent protection within equipment during short circuit output terminal or some fault condition. Short-circuit backup protection or external overcurrent protection mechanism shall be provided external to the equipment or in the building installation with rating 40 A.
7. Input terminals involved energy hazard existence is protected by fixed cover. Such terminals are inaccessible after installation and the cover is marked with  to discourage OPERATOR during normal use.

Abbreviations used in the report:

- normal conditions	N.C.	- single fault conditions	S.F.C
- functional insulation	OP	- basic insulation	BI
- double insulation	DI	- supplementary insulation	SI
- between parts of opposite polarity	BOP	- reinforced insulation	RI

Indicate used abbreviations (if any)

LVD TEST REPORT

IEC60950_1B - ATTACHMENT			
Clause	Requirement + Test	Result - Remark	Verdict
1	GENERAL		P
1.5	Components		P
1.5.1	General		P
	Comply with IEC 60950-1 or relevant component standard	(see appended tables 1.5.1)	P
1.5.2	Evaluation and testing of components	Components which are certified to IEC and /or national standard are used correctly within their ratings.	P
1.5.3	Thermal controls		N
1.5.4	Transformers	(see also Annex C)	P
1.5.5	Interconnecting cables		N
1.5.6	Capacitors bridging insulation	X2 Cap. C67 Bridging L and N Y1 Cap. C9 Bridging Pri and Sec. circuit.	P
1.5.7	Resistors bridging insulation		N
1.5.7.1	Resistors bridging functional, basic or supplementary insulation		N
1.5.7.2	Resistors bridging double or reinforced insulation between a.c. mains and other circuits		N
1.5.7.3	Resistors bridging double or reinforced insulation between a.c. mains and antenna or coaxial cable		N
1.5.8	Components in equipment for IT power systems	No such components	N
1.5.9	Surge suppressors	(see appended tables 1.5.1)	P
1.5.9.1	General	Approve surge suppressor (RV1) used between Line and Neutral	P
1.5.9.2	Protection of VDRs		P
1.5.9.3	Bridging of functional insulation by a VDR		P
1.5.9.4	Bridging of basic insulation by a VDR		N
1.5.9.5	Bridging of supplementary, double or reinforced insulation by a VDR		N
1.6	Power interface		P
1.6.1	AC power distribution systems		P
1.6.2	Input current	(see appended table 1.6.2)	P

LVD TEST REPORT

IEC60950_1B - ATTACHMENT			
Clause	Requirement + Test	Result - Remark	Verdict
1.6.3	Voltage limit of hand-held equipment	The EUT is not hand-held equipment	N
1.6.4	Neutral conductor		N
1.7	Marking and instructions		P
1.7.1	Power rating and identification markings	Refer page 1	P
1.7.1.1	Power rating marking		P
	Multiple mains supply connections.....:	AC Input or Batteries input:or PV input	P
	Rated voltage(s) or voltage range(s) (V)	230 V for AC or 24 V or 125 V for DC	P
	Symbol for nature of supply, for d.c. only	⎓ for DC ~ for AC	P
	Rated frequency or rated frequency range (Hz) ...:	DC	N
	Rated current (mA or A)	17,7 A for AC input 50 A for PV input 100 A for Batteries input	P
1.7.1.2	Identification markings		P
	Manufacturer's name or trade-mark or identification mark	MPP Solar Inc	P
	Model identification or type reference	PIP 2424HS	P
	Symbol for Class II equipment only		N
	Other markings and symbols		N
1.7.2	Safety instructions and marking	User manual are provided	P
1.7.2.1	General		P
1.7.2.2	Disconnect devices	A readily accessible disconnect device shall be incorporated external to the equipment	P
1.7.2.3	Overcurrent protective device	Circuit breaker within equipment and Short-circuit backup protection or external overcurrent protection mechanism rated 40 A shall be provided external to the equipment or in the building installation	P
1.7.2.4	IT power distribution systems		N

LVD TEST REPORT

IEC60950_1B - ATTACHMENT																															
Clause	Requirement + Test	Result - Remark	Verdict																												
1.7.2.5	Operator access with a tool		N																												
1.2.7.6	Ozone		N																												
1.7.3	Short duty cycles	Continuous operation	N																												
1.7.4	Supply voltage adjustment	No voltage selector	N																												
	Methods and means of adjustment; reference to installation instructions		N																												
1.7.5	Power outlets on the equipment		P																												
1.7.6	Fuse identification (marking, special fusing characteristics, cross-reference)	Fuse F1 ~ F6 for batteries protection: 30VDC, 40A	P																												
1.7.7	Wiring terminals		P																												
1.7.7.1	Protective earthing and bonding terminals		P																												
1.7.7.2	Terminals for a.c. mains supply conductors		P																												
1.7.7.3	Terminals for d.c. mains supply conductors	“+” and “-“	P																												
1.7.8	Controls and indicators	LED indicator as following: <table border="1" style="width: 100%; border-collapse: collapse;"> <thead> <tr> <th colspan="2">LED Indicator</th> <th colspan="2">Messages</th> </tr> </thead> <tbody> <tr> <td>● AC INV</td> <td>Green</td> <td>Solid On</td> <td>Output is available in Inverter mode</td> </tr> <tr> <td></td> <td></td> <td>Flashing</td> <td>Output is generated by battery in inverter mode</td> </tr> <tr> <td>● CHG</td> <td>Green</td> <td>Solid On</td> <td>Battery is fully charged</td> </tr> <tr> <td></td> <td></td> <td>Flashing</td> <td>Battery is charging</td> </tr> <tr> <td>△ FAULT</td> <td>Red</td> <td>Solid On</td> <td>Fault mode</td> </tr> <tr> <td></td> <td></td> <td>Flashing</td> <td>Warning mode</td> </tr> </tbody> </table>	LED Indicator		Messages		● AC INV	Green	Solid On	Output is available in Inverter mode			Flashing	Output is generated by battery in inverter mode	● CHG	Green	Solid On	Battery is fully charged			Flashing	Battery is charging	△ FAULT	Red	Solid On	Fault mode			Flashing	Warning mode	P
LED Indicator		Messages																													
● AC INV	Green	Solid On	Output is available in Inverter mode																												
		Flashing	Output is generated by battery in inverter mode																												
● CHG	Green	Solid On	Battery is fully charged																												
		Flashing	Battery is charging																												
△ FAULT	Red	Solid On	Fault mode																												
		Flashing	Warning mode																												
1.7.8.1	Identification, location and marking	On operational switch	P																												
1.7.8.2	Colours	Green for “POWER” Red for “FAULT”	P																												
1.7.8.3	Symbols according to IEC 60417	Line for “ON” Circle for “OFF”	P																												
1.7.8.4	Markings using figures		N																												
1.7.9	Isolation of multiple power sources		P																												
1.7.10	Thermostats and other regulating devices	No thermostats operation under normal operation	N																												
1.7.11	Durability		P																												
1.7.12	Removable parts	No such parts	N																												
1.7.13	Replaceable batteries	No battery within the EUT	N																												
	Language(s)	English	—																												
1.7.14	Equipment for restricted access locations	The EUT is not such type	N																												
2	PROTECTION FROM HAZARDS		P																												
2.1	Protection from electric shock and energy hazards		P																												
2.1.1	Protection in operator access areas		P																												

LVD TEST REPORT

IEC60950_1B - ATTACHMENT			
Clause	Requirement + Test	Result - Remark	Verdict
2.1.1.1	Access to energized parts	No energized parts can be accessed	P
	Test by inspection		P
	Test with test finger (Figure 2A)		P
	Test with test pin (Figure 2B)		P
	Test with test probe (Figure 2C)	No TNV circuit within the EUT	N
2.1.1.2	Battery compartments	No battery compartment within the EUT	N
2.1.1.3	Access to ELV wiring	No ELV circuit within the EUT	N
	Working voltage (V_{peak} or V_{rms}); minimum distance through insulation (mm)	(see appended tables 2.10.2 and 2.10.5)	—
2.1.1.4	Access to hazardous voltage circuit wiring	Input and Output output terminal are not accessible	P
2.1.1.5	Energy hazards	Input >240VA	N
2.1.1.6	Manual controls	No such device	N
2.1.1.7	Discharge of capacitors in equipment	AC permanent connection with terminals. No OPERATOR-accessible external point	N
	Measured voltage (V); time-constant (s)		—
2.1.1.8	Energy hazards – d.c. mains supply		N
	a) Capacitor connected to the d.c. mains supply . :		N
	b) Internal battery connected to the d.c. mains supply		N
2.1.1.9	Audio amplifiers	No such equipment	N
2.1.2	Protection in service access areas		N
2.1.3	Protection in restricted access locations		N
2.2	SELV circuits		P
2.2.1	General requirements		P
2.2.2	Voltages under normal conditions (V)	RJ45 terminal < 5 V for communication	P
2.2.3	Voltages under fault conditions (V)	RJ45 terminal < 5 V for Fault condition	P
2.2.4	Connection of SELV circuits to other circuits		P
2.3	TNV circuits		N
2.3.1	Limits	No TNV circuit	N

LVD TEST REPORT

IEC60950_1B - ATTACHMENT			
Clause	Requirement + Test	Result - Remark	Verdict
	Type of TNV circuits		—
2.3.2	Separation from other circuits and from accessible parts		N
2.3.2.1	General requirements		N
2.3.2.2	Protection by basic insulation		N
2.3.2.3	Protection by earthing		N
2.3.2.4	Protection by other constructions		N
2.3.3	Separation from hazardous voltages		N
	Insulation employed.....		—
2.3.4	Connection of TNV circuits to other circuits		N
	Insulation employed.....		—
2.3.5	Test for operating voltages generated externally		N
2.4	Limited current circuits		N
2.4.1	General requirements		N
2.4.2	Limit values		N
	Frequency (Hz)		—
	Measured current (mA)		—
	Measured voltage (V)		—
	Measured circuit capacitance (nF or μ F)		—
2.4.3	Connection of limited current circuits to other circuits		N
2.5	Limited power sources		N
	a) Inherently limited output		N
	b) Impedance limited output		N
	c) Regulating network limited output under normal operating and single fault condition		N
	d) Overcurrent protective device limited output		N
	Max. output voltage (V), max. output current (A), max. apparent power (VA)	(see appended table 2.5)	—
	Current rating of overcurrent protective device (A) :		—
	Use of integrated circuit (IC) current limiters	(See Annex CC)	N
2.6	Provisions for earthing and bonding		P

LVD TEST REPORT

IEC60950_1B - ATTACHMENT			
Clause	Requirement + Test	Result - Remark	Verdict
2.6.1	Protective earthing		P
2.6.2	Functional earthing		N
2.6.3	Protective earthing and protective bonding conductors		P
2.6.3.1	General		P
2.6.3.2	Size of protective earthing conductors	2,5 mm ² , 12 AWG	P
	Rated current (A), cross-sectional area (mm ²), AWG		—
2.6.3.3	Size of protective bonding conductors		P
	Rated current (A), cross-sectional area (mm ²), AWG	Protective bonding conductors comply with 2.6.3.4	—
	Protective current rating (A), cross-sectional area (mm ²), AWG.....	2,5 mm ² , 12 AWG	—
2.6.3.4	Resistance of earthing conductors and their terminations; resistance (Ω), voltage drop (V), test current (A), duration (min).....	Resistance: 0,04 Ω, Test current: 32 A for 2 minutes	P
2.6.3.5	Colour of insulation.....	Green Yellow wire used	P
2.6.4	Terminals		N
2.6.4.1	General		N
2.6.4.2	Protective earthing and bonding terminals		N
	Rated current (A), type, nominal thread diameter (mm)		—
2.6.4.3	Separation of the protective earthing conductor from protective bonding conductors		P
2.6.5	Integrity of protective earthing		P
2.6.5.1	Interconnection of equipment		N
2.6.5.2	Components in protective earthing conductors and protective bonding conductors	No components in earthing conductors	P
2.6.5.3	Disconnection of protective earth		N
2.6.5.4	Parts that can be removed by an operator		N
2.6.5.5	Parts removed during servicing		N
2.6.5.6	Corrosion resistance	See annex J	P
2.6.5.7	Screws for protective bonding		P
2.6.5.8	Reliance on telecommunication network or cable distribution system		N
2.7	Overcurrent and earth fault protection in primary circuits		P

LVD TEST REPORT

IEC60950_1B - ATTACHMENT			
Clause	Requirement + Test	Result - Remark	Verdict

2.7.1	Basic requirements		P
	Instructions when protection relies on building installation		N
2.7.2	Faults not simulated in 5.3.7		N
2.7.3	Short-circuit backup protection	Short-circuit backup protection or external overcurrent protection mechanism shall be provided external to the equipment or in the building installation.	P
2.7.4	Number and location of protective devices :	Circuit breaker is located in "L" polarity	P
2.7.5	Protection by several devices		N
2.7.6	Warning to service personnel :	The EUT is not such kind of design	N

2.8	Safety interlocks		N
2.8.1	General principles	No safety interlock or similar devices used within the EUT	N
2.8.2	Protection requirements		N
2.8.3	Inadvertent reactivation		N
2.8.4	Fail-safe operation		N
	Protection against extreme hazard		N
2.8.5	Moving parts		N
2.8.6	Overriding		N
2.8.7	Switches, relays and their related circuits		N
2.8.7.1	Separation distances for contact gaps and their related circuits (mm) :		N
2.8.7.2	Overload test		N
2.8.7.3	Endurance test		N
2.8.7.4	Electric strength test	(see appended table 5.2)	N
2.8.8	Mechanical actuators		N

2.9	Electrical insulation		P
2.9.1	Properties of insulating materials	Natural rubber, hygroscopic materials or asbestos are not used	P
2.9.2	Humidity conditioning	48 hours	P

LVD TEST REPORT

IEC60950_1B - ATTACHMENT			
Clause	Requirement + Test	Result - Remark	Verdict
	Relative humidity (%), temperature (°C)	95 %	—
2.9.3	Grade of insulation	25 °C	P
2.9.4	Separation from hazardous voltages	Considered	P
	Method(s) used	Method 1	—

2.10	Clearances, creepage distances and distances through insulation		P
2.10.1	General	See 2.10.3, 2.10.4 and 2.10.5	P
2.10.1.1	Frequency	Considered	P
2.10.1.2	Pollution degrees	Pollution Degree 2	P
2.10.1.3	Reduced values for functional insulation	See 5.3.4	P
2.10.1.4	Intervening unconnected conductive parts		P
2.10.1.5	Insulation with varying dimensions		P
2.10.1.6	Special separation requirements	No TNV	N
2.10.1.7	Insulation in circuits generating starting pulses	No such circuit	N
2.10.2	Determination of working voltage	The rms and the peak voltage were measure on the insulated transformer	P
2.10.2.1	General		P
2.10.2.2	RMS working voltage	285 Vrms	P
2.10.2.3	Peak working voltage	540 Vpeak	P
2.10.3	Clearances		P
2.10.3.1	General		P
2.10.3.2	Mains transient voltages	See below	P
	a) AC mains supply	2500V	P
	b) Earthed d.c. mains supplies		N
	c) Unearthed d.c. mains supplies		N
	d) Battery operation		N
2.10.3.3	Clearances in primary circuits	(see appended table 2.10.3 and 2.10.4)	P
2.10.3.4	Clearances in secondary circuits	(see appended table 2.10.3 and 2.10.4)	P
2.10.3.5	Clearances in circuits having starting pulses	(see appended table 2.10.3 and 2.10.4)	N
2.10.3.6	Transients from a.c. mains supply	Normal transient voltage considered (overvoltage category II for primary circuit)	P
2.10.3.7	Transients from d.c. mains supply		N

LVD TEST REPORT

IEC60950_1B - ATTACHMENT			
Clause	Requirement + Test	Result - Remark	Verdict
2.10.3.8	Transients from telecommunication networks and cable distribution systems	No TNV circuit	N
2.10.3.9	Measurement of transient voltage levels		N
	a) Transients from a mains supply		N
	For an a.c. mains supply		N
	For a d.c. mains supply		N
	b) Transients from a telecommunication network :		N
2.10.4	Creepage distances		P
2.10.4.1	General		P
2.10.4.2	Material group and comparative tracking index		P
	CTI tests	Material group IIIb is assumed to be used	—
2.10.4.3	Minimum creepage distances	(see appended table 2.10.3 and 2.10.4)	P
2.10.5	Solid insulation		P
2.10.5.1	General		P
2.10.5.2	Distances through insulation	(see appended table 2.10.5)	P
2.10.5.3	Insulating compound as solid insulation		N
2.10.5.4	Semiconductor devices		P
2.10.5.5.	Cemented joints	(see appended table 2.10.3 and 2.10.4)	N
2.10.5.6	Thin sheet material – General	Insulation tape was wraparound the insulation transformer for Basic insulation	P
2.10.5.7	Separable thin sheet material	See above	P
	Number of layers (pcs).....	2 layers	—
2.10.5.8	Non-separable thin sheet material	No such thin sheet material	N
2.10.5.9	Thin sheet material – standard test procedure		N
	Electric strength test	(see appended table 2.10.5)	—
2.10.5.10	Thin sheet material – alternative test procedure		P
	Electric strength test	(see appended table 2.10.5)	—
2.10.5.11	Insulation in wound components		N
2.10.5.12	Wire in wound components		N
	Working voltage		N
	a) Basic insulation not under stress		N

LVD TEST REPORT

IEC60950_1B - ATTACHMENT			
Clause	Requirement + Test	Result - Remark	Verdict
	b) Basic, supplementary, reinforced insulation		N
	c) Compliance with Annex U		N
	Two wires in contact inside wound component; angle between 45° and 90°		N
2.10.5.13	Wire with solvent-based enamel in wound components		N
	Electric strength test	(see appended table 2.10.5)	—
	Routine test		N
2.10.5.14	Additional insulation in wound components		N
	Working voltage		N
	- Basic insulation not under stress		N
	- Supplementary, reinforced insulation		N
2.10.6	Construction of printed boards		P
2.10.6.1	Uncoated printed boards	(see appended table 2.10.3 and 2.10.4)	P
2.10.6.2	Coated printed boards		N
2.10.6.3	Insulation between conductors on the same inner surface of a printed board	No multi-layer PCBs provided	N
2.10.6.4	Insulation between conductors on different layers of a printed board		N
	Distance through insulation		N
	Number of insulation layers (pcs)		N
2.10.7	Component external terminations	(see appended table 2.10.3 and 2.10.4)	N
2.10.8	Tests on coated printed boards and coated components		N
2.10.8.1	Sample preparation and preliminary inspection		N
2.10.8.2	Thermal conditioning		N
2.10.8.3	Electric strength test	(see appended table 5.2)	N
2.10.8.4	Abrasion resistance test		N
2.10.9	Thermal cycling		N
2.10.10	Test for Pollution Degree 1 environment and insulating compound		N
2.10.11	Tests for semiconductor devices and cemented joints		N
2.10.12	Enclosed and sealed parts		N

LVD TEST REPORT

IEC60950_1B - ATTACHMENT			
Clause	Requirement + Test	Result - Remark	Verdict

3	WIRING, CONNECTIONS AND SUPPLY		P
3.1	General		P
3.1.1	Current rating and overcurrent protection	Internal wires are UL recognized wiring which PVC insulated, rated VW-1, min.80°C and having gauge suitable for current intended to be carried.	P
3.1.2	Protection against mechanical damage	Wires do not touch sharp edges which could damage the insulation and cause hazard.	P
3.1.3	Securing of internal wiring	Internal wires are secured by solder pins, and glue so that a loosening of the terminal connection is unlikely.	P
3.1.4	Insulation of conductors	See appended table 5.2	P
3.1.5	Beads and ceramic insulators	Not used	N
3.1.6	Screws for electrical contact pressure	No such screws are used	N
3.1.7	Insulating materials in electrical connections		N
3.1.8	Self-tapping and spaced thread screws	No such screws are used	N
3.1.9	Termination of conductors	All conductor are reliable secured	P
	10 N pull test	Force of 10N applied to the termination points of the conductors	P
3.1.10	Sleeving on wiring	No sleeving used to provided supplementary insulation	N

3.2	Connection to a mains supply		P
3.2.1	Means of connection		P
3.2.1.1	Connection to an a.c. mains supply		P
3.2.1.2	Connection to a d.c. mains supply		P
3.2.2	Multiple supply connections		P
3.2.3	Permanently connected equipment		P
	Number of conductors, diameter of cable and conduits (mm)	12 AWG X 3 for supply	—
3.2.4	Appliance AC connectors		N
3.2.5	Power supply cords		N

LVD TEST REPORT

IEC60950_1B - ATTACHMENT			
Clause	Requirement + Test	Result - Remark	Verdict
3.2.5.1	AC power supply cords		N
	Type		—
	Rated current (A), cross-sectional area (mm ²), AWG		—
3.2.5.2	DC power supply cords		N
3.2.6	Cord anchorages and strain relief	Shall be reevaluated after permanent connectio	N
	Mass of equipment (kg), pull (N)	--	—
	Longitudinal displacement (mm)	--	—
3.2.7	Protection against mechanical damage		P
3.2.8	Cord guards		P
	Diameter or minor dimension D (mm); test mass (g)	3 x 12 AWG for AC	—
	Radius of curvature of cord (mm)		—
3.2.9	Supply wiring space		P
3.3	Wiring terminals for connection of external conductors		P
3.3.1	Wiring terminals		P
3.3.2	Connection of non-detachable power supply cords		P
3.3.3	Screw terminals		P
3.3.4	Conductor sizes to be connected		P
	Rated current (A), cord/cable type, cross-sectional area (mm ²)	20 A, 3 x 12AWG for AC; 100 A and 50 A for Batteries and PV terminal: 2 X 8AWG	—
3.3.5	Wiring terminal sizes		P
	Rated current (A), type, nominal thread diameter (mm)	Suitable for 3 x 12 AWG for AC For Batteries and PV terminal: 2 X 8AWG	—
3.3.6	Wiring terminal design		N
3.3.7	Grouping of wiring terminals		N
3.3.8	Stranded wire		N
3.4	Disconnection from the mains supply		P
3.4.1	General requirement		P

LVD TEST REPORT

IEC60950_1B - ATTACHMENT			
Clause	Requirement + Test	Result - Remark	Verdict

3.4.2	Disconnect devices	Shall be provide external	P
3.4.3	Permanently connected equipment	Shall be provide external	P
3.4.4	Parts which remain energized		N
3.4.5	Switches in flexible cords	No switch in flexible cords	N
3.4.6	Number of poles - single-phase and d.c. equipment		P
3.4.7	Number of poles - three-phase equipment		N
3.4.8	Switches as disconnect devices		N
3.4.9	Plugs as disconnect devices		N
3.4.10	Interconnected equipment		N
3.4.11	Multiple power sources		N

3.5	Interconnection of equipment		N
3.5.1	General requirements		N
3.5.2	Types of interconnection circuits :		N
3.5.3	ELV circuits as interconnection circuits		N
3.5.4	Data ports for additional equipment		N

4	PHYSICAL REQUIREMENTS		P
4.1	Stability		N
	Angle of 10°		N
	Test force (N) :		N

4.2	Mechanical strength		P
4.2.1	General		P
	Rack-mounted equipment.	(see Annex DD)	N
4.2.2	Steady force test, 10 N	The EUT is still complying with relevant requirements of this standard after 10 N force is applied to the components	P
4.2.3	Steady force test, 30 N	No internal enclosure in the sense of this standard	N
4.2.4	Steady force test, 250 N	The EUT is still complying with relevant requirements of this standard (all the enclosure materials listed in the table 1.5.1 are tested)	P

LVD TEST REPORT

IEC60950_1B - ATTACHMENT			
Clause	Requirement + Test	Result - Remark	Verdict
4.2.5	Impact test	Test on enclosure	P
	Fall test	Test on enclosure	P
	Swing test	Test on enclosure	P
4.2.6	Drop test; height (mm) :		N
4.2.7	Stress relief test		N
4.2.8	Cathode ray tubes		N
	Picture tube separately certified :		N
4.2.9	High pressure lamps		N
4.2.10	Wall or ceiling mounted equipment; force (N) :		N
4.2.11	Rotating solid media		N
	Test to cover on the door.....:		N

4.3	Design and construction		P
4.3.1	Edges and corners		P
4.3.2	Handles and manual controls; force (N) :	No handle or control provided	N
4.3.3	Adjustable controls		N
4.3.4	Securing of parts	Mechanical fixings in such a way designed that they will withstand mechanical stress occurring in normal use	P
4.3.5	Connection by plugs and sockets		P
4.3.6	Direct plug-in equipment	Not direct plug-in equipment	N
	Torque :		—
	Compliance with the relevant mains plug standard :		N
4.3.7	Heating elements in earthed equipment	No such device within the EUT	N
4.3.8	Batteries	On External Batteries use for UPS	N
	- Overcharging of a rechargeable battery		N
	- Unintentional charging of a non-rechargeable battery		N
	- Reverse charging of a rechargeable battery		N
	- Excessive discharging rate for any battery		N
4.3.9	Oil and grease		N
4.3.10	Dust, powders, liquids and gases		N

LVD TEST REPORT

IEC60950_1B - ATTACHMENT			
Clause	Requirement + Test	Result - Remark	Verdict
4.3.11	Containers for liquids or gases		N
4.3.12	Flammable liquids		N
	Quantity of liquid (l)		N
	Flash point (°C)		N
4.3.13	Radiation	LED as indication lights	P
4.3.13.1	General		P
4.3.13.2	Ionizing radiation	No ionizing radiation	N
	Measured radiation (pA/kg)		—
	Measured high-voltage (kV)		—
	Measured focus voltage (kV)		—
	CRT markings		—
4.3.13.3	Effect of ultraviolet (UV) radiation on materials		N
	Part, property, retention after test, flammability classification		N
4.3.13.4	Human exposure to ultraviolet (UV) radiation		N
4.3.13.5	Lasers (including laser diodes) and LEDs		P
4.3.13.5.1	Lasers (including laser diodes)	LED as indication lights	P
	Laser class	1	—
4.3.13.5.2	Light emitting diodes (LEDs)		—
4.3.13.6	Other types		N
4.4	Protection against hazardous moving parts		N
4.4.1	General	No hazardous moving parts within the EUT	N
4.4.2	Protection in operator access areas		N
	Household and home/office document/media shredders	(see Annex EE)	N
4.4.3	Protection in restricted access locations		N
4.4.4	Protection in service access areas		N
4.4.5	Protection against moving fan blades		N
4.4.5.1	General		N
	Not considered to cause pain or injury. a).....:		N
	Is considered to cause pain, not injury. b)		N

LVD TEST REPORT

IEC60950_1B - ATTACHMENT			
Clause	Requirement + Test	Result - Remark	Verdict

	Considered to cause injury. c)		N
4.4.5.2	Protection for users		N
	Use of symbol or warning		N
4.4.5.3	Protection for service persons		N
	Use of symbol or warning		N

4.5	Thermal requirements		P
4.5.1	General		P
4.5.2	Temperature tests	See below	P
	Normal load condition per Annex L	Operated in the most unfavourable condition	—
4.5.3	Temperature limits for materials	(see appended table 4.5)	P
4.5.4	Touch temperature limits	(see appended table 4.5)	P
4.5.5	Resistance to abnormal heat	(see appended table 4.5.5)	P

4.6	Openings in enclosures		P
4.6.1	Top and side openings		P
	Dimensions (mm)	Not live part expose on 5° area.	—
4.6.2	Bottoms of fire enclosures	No Opening on bottom	N
	Construction of the bottom, dimensions (mm) . :		—
4.6.3	Doors or covers in fire enclosures		N
4.6.4	Openings in transportable equipment		N
4.6.4.1	Constructional design measures		N
	Dimensions (mm)		—
4.6.4.2	Evaluation measures for larger openings		N
4.6.4.3	Use of metallized parts		N
4.6.5	Adhesives for constructional purposes		N
	Conditioning temperature (°C), time (weeks)..... :		—

4.7	Resistance to fire		P
4.7.1	Reducing the risk of ignition and spread of flame		P

LVD TEST REPORT

IEC60950_1B - ATTACHMENT			
Clause	Requirement + Test	Result - Remark	Verdict
	Method 1, selection and application of components wiring and materials	(see appended table 4.7)	P
	Method 2, application of all of simulated fault condition tests	(see appended table 5.3)	N
4.7.2	Conditions for a fire enclosure	Following parts require a fire enclosure: - Components in primary circuits - Components in secondary circuits supplied by power sources that exceed the limits of limited power source. fire enclosure is required..	P
4.7.2.1	Parts requiring a fire enclosure	See above	P
4.7.2.2	Parts not requiring a fire enclosure		N
4.7.3	Materials		P
4.7.3.1	General	Parts mounted on PCB of flammability class V-0 or better.	P
4.7.3.2	Materials for fire enclosures	Metal enclosure	P
4.7.3.3	Materials for components and other parts outside fire enclosures	No part outside fire enclosure.	N
4.7.3.4	Materials for components and other parts inside fire enclosures	(see appended table 1.5.1)	P
4.7.3.5	Materials for air filter assemblies	No such device within the EUT	N
4.7.3.6	Materials used in high-voltage components	No such device within the EUT	N

5	ELECTRICAL REQUIREMENTS AND SIMULATED ABNORMAL CONDITIONS		P
5.1	Touch current and protective conductor current		P
5.1.1	General	See sub-clauses 5.1.2 to 5.1.6	P
5.1.2	Configuration of equipment under test (EUT)		P
5.1.2.1	Single connection to an a.c. mains supply		P
5.1.2.2	Redundant multiple connections to an a.c. mains supply		N
5.1.2.3	Simultaneous multiple connections to an a.c. mains supply		N

LVD TEST REPORT

IEC60950_1B - ATTACHMENT			
Clause	Requirement + Test	Result - Remark	Verdict
5.1.3	Test circuit	Test circuit as in figure 5A is used	P
5.1.4	Application of measuring instrument	Measuring instrument as in annex D.1 is used	P
5.1.5	Test procedure		P
5.1.6	Test measurements		P
	Supply voltage (V)	253 V~	—
	Measured touch current (mA)	Measure at enclosure: 0,13 mA max.	—
	Max. allowed touch current (mA)	3,5 mA	—
	Measured protective conductor current (mA)		—
	Max. allowed protective conductor current (mA) . :		—
5.1.7	Equipment with touch current exceeding 3,5 mA	No such equipment	N
5.1.7.1	General	No TNV circuit within the EUT	N
5.1.7.2	Simultaneous multiple connections to the supply		N
5.1.8	Touch currents to telecommunication networks and cable distribution systems and from telecommunication networks		N
5.1.8.1	Limitation of the touch current to a telecommunication network or to a cable distribution system		N
	Supply voltage (V)		—
	Measured touch current (mA)		—
	Max. allowed touch current (mA)		—
5.1.8.2	Summation of touch currents from telecommunication networks		N
	a) EUT with earthed telecommunication ports :		N
	b) EUT whose telecommunication ports have no reference to protective earth		N

5.2	Electric strength		P
5.2.1	General	(see appended table 5.2)	P
5.2.2	Test procedure	(see appended table 5.2)	P

5.3	Abnormal operating and fault conditions		P
5.3.1	Protection against overload and abnormal operation	Output overload test, the most unfavorable load test (see appended table 5.3)	P

LVD TEST REPORT

IEC60950_1B - ATTACHMENT			
Clause	Requirement + Test	Result - Remark	Verdict
5.3.2	Motors	Fan	P
5.3.3	Transformers	(see appended Annex C)	P
5.3.4	Functional insulation	Method c) ters results see appended table 5.3	P
5.3.5	Electromechanical components	No such components within EUT	N
5.3.6	Audio amplifiers in ITE		N
5.3.7	Simulation of faults	See appended table 5.3	P
5.3.8	Unattended equipment		N
5.3.9	Compliance criteria for abnormal operating and fault conditions	No fire propagated beyond the equipment. No molten metal was emitted. Electric strength test primary to SELV was passed	P
5.3.9.1	During the tests		P
5.3.9.2	After the tests		P
6	CONNECTION TO TELECOMMUNICATION NETWORKS		N
6.1	Protection of telecommunication network service persons, and users of other equipment connected to the network, from hazards in the equipment		N
6.1.1	Protection from hazardous voltages		N
6.1.2	Separation of the telecommunication network from earth		N
6.1.2.1	Requirements	(see appended table 5.2)	N
	Supply voltage (V)		—
	Current in the test circuit (mA)		—
6.1.2.2	Exclusions		N
6.2	Protection of equipment users from overvoltages on telecommunication networks		N
6.2.1	Separation requirements		N
6.2.2	Electric strength test procedure		N
6.2.2.1	Impulse test	(see appended table 5.2)	N
6.2.2.2	Steady-state test	(see appended table 5.2)	N
6.2.2.3	Compliance criteria		N
6.3	Protection of the telecommunication wiring system from overheating		N
	Max. output current (A)		—

LVD TEST REPORT

IEC60950_1B - ATTACHMENT			
Clause	Requirement + Test	Result - Remark	Verdict

	Current limiting method		—
--	-------------------------------	--	---

7	CONNECTION TO CABLE DISTRIBUTION SYSTEMS		N
7.1	General		N
7.2	Protection of cable distribution system service persons, and users of other equipment connected to the system, from hazardous voltages in the equipment		N
7.3	Protection of equipment users from overvoltages on the cable distribution system		N
7.4	Insulation between primary circuits and cable distribution systems		N
7.4.1	General		N
7.4.2	Voltage surge test	(see appended table 5.2)	N
7.4.3	Impulse test	(see appended table 5.2)	N

A	ANNEX A, TESTS FOR RESISTANCE TO HEAT AND FIRE		N
A.1	Flammability test for fire enclosures of movable equipment having a total mass exceeding 18 kg, and of stationary equipment (see 4.7.3.2)		N
A.1.1	Samples		—
	Wall thickness (mm)		—
A.1.2	Conditioning of samples; temperature (°C)		N
A.1.3	Mounting of samples		N
A.1.4	Test flame (see IEC 60695-11-3)		N
	Flame A, B, C or D		—
A.1.5	Test procedure		N
A.1.6	Compliance criteria		N
	Sample 1 burning time (s).....		—
	Sample 2 burning time (s).....		—
	Sample 3 burning time (s).....		—
A.2	Flammability test for fire enclosures of movable equipment having a total mass not exceeding 18 kg, and for material and components located inside fire enclosures (see 4.7.3.2 and 4.7.3.4)		N
A.2.1	Samples, material.....		—
	Wall thickness (mm)		—

LVD TEST REPORT

IEC60950_1B - ATTACHMENT			
Clause	Requirement + Test	Result - Remark	Verdict
A.2.2	Conditioning of samples; temperature (°C)		N
A.2.3	Mounting of samples		N
A.2.4	Test flame (see IEC 60695-11-4)		N
	Flame A, B or C		—
A.2.5	Test procedure		N
A.2.6	Compliance criteria		N
	Sample 1 burning time (s).....		—
	Sample 2 burning time (s).....		—
	Sample 3 burning time (s).....		—
A.2.7	Alternative test acc. to IEC 60695-11-5, cl. 5 and 9		N
	Sample 1 burning time (s).....		—
	Sample 2 burning time (s).....		—
	Sample 3 burning time (s).....		—
A.3	Hot flaming oil test (see 4.6.2)		N
A.3.1	Mounting of samples		N
A.3.2	Test procedure		N
A.3.3	Compliance criterion		N

B	ANNEX B, MOTOR TESTS UNDER ABNORMAL CONDITIONS (see 4.7.2.2 and 5.3.2)		P
B.1	General requirements	DC Fan have been test complied with B.6, B.7 and B.10	N
	Position		—
	Manufacturer		—
	Type		—
	Rated values		—
B.2	Test conditions		N
B.3	Maximum temperatures	(see appended table 5.3)	N
B.4	Running overload test	(see appended table 5.3)	N
B.5	Locked-rotor overload test		N
	Test duration (days)		—
	Electric strength test: test voltage (V)		—
B.6	Running overload test for d.c. motors in secondary circuits		P

LVD TEST REPORT

IEC60950_1B - ATTACHMENT			
Clause	Requirement + Test	Result - Remark	Verdict
B.6.1	General		P
B.6.2	Test procedure		P
B.6.3	Alternative test procedure		P
B.6.4	Electric strength test; test voltage (V) :		P
B.7	Locked-rotor overload test for d.c. motors in secondary circuits		P
B.7.1	General		P
B.7.2	Test procedure		P
B.7.3	Alternative test procedure		P
B.7.4	Electric strength test; test voltage (V) :	1500	P
B.8	Test for motors with capacitors	(see appended table 5.3)	N
B.9	Test for three-phase motors	(see appended table 5.3)	N
B.10	Test for series motors		N
	Operating voltage (V) :		—

C	ANNEX C, TRANSFORMERS (see 1.5.4 and 5.3.3)		P
	Position :	T1	—
	Manufacturer :	See table 1.5.1	—
	Type :	See table 1.5.1	—
	Rated values :	See table 1.5.1	—
	Method of protection..... :	Inherent	—
C.1	Overload test	See appended table 5.3	P
C.2	Insulation	See appended table 5.2 and C2	P
	Protection from displacement of windings..... :	Fixed by bobbin and margent tape	P

D	ANNEX D, MEASURING INSTRUMENTS FOR TOUCH-CURRENT TESTS (see 5.1.4)		N
D.1	Measuring instrument		P
D.2	Alternative measuring instrument		N

E	ANNEX E, TEMPERATURE RISE OF A WINDING (see 1.4.13)		N
----------	--	--	---

F	ANNEX F, MEASUREMENT OF CLEARANCES AND CREEPAGE DISTANCES (see 2.10 and Annex G)		P
----------	---	--	---

LVD TEST REPORT

IEC60950_1B - ATTACHMENT			
Clause	Requirement + Test	Result - Remark	Verdict

G	ANNEX G, ALTERNATIVE METHOD FOR DETERMINING MINIMUM CLEARANCES		N
G.1	Clearances		N
G.1.1	General		N
G.1.2	Summary of the procedure for determining minimum clearances		N
G.2	Determination of mains transient voltage (V)		N
G.2.1	AC mains supply		N
G.2.2	Earthed d.c. mains supplies		N
G.2.3	Unearthed d.c. mains supplies		N
G.2.4	Battery operation		N
G.3	Determination of telecommunication network transient voltage (V)		N
G.4	Determination of required withstand voltage (V)		N
G.4.1	Mains transients and internal repetitive peaks		N
G.4.2	Transients from telecommunication networks		N
G.4.3	Combination of transients		N
G.4.4	Transients from cable distribution systems		N
G.5	Measurement of transient voltages (V)		N
	a) Transients from a mains supply		N
	For an a.c. mains supply		N
	For a d.c. mains supply		N
	b) Transients from a telecommunication network		N
G.6	Determination of minimum clearances		N

H	ANNEX H, IONIZING RADIATION (see 4.3.13)		N
----------	---	--	---

J	ANNEX J, TABLE OF ELECTROCHEMICAL POTENTIALS (see 2.6.5.6)		P
	Metal(s) used		—

K	ANNEX K, THERMAL CONTROLS (see 1.5.3 and 5.3.8)		N
K.1	Making and breaking capacity		N
K.2	Thermostat reliability; operating voltage (V)		N
K.3	Thermostat endurance test; operating voltage (V)		N

LVD TEST REPORT

IEC60950_1B - ATTACHMENT			
Clause	Requirement + Test	Result - Remark	Verdict

K.4	Temperature limiter endurance; operating voltage (V)		N
K.5	Thermal cut-out reliability		N
K.6	Stability of operation	(see appended table 5.3)	N

L	ANNEX L, NORMAL LOAD CONDITIONS FOR SOME TYPES OF ELECTRICAL BUSINESS EQUIPMENT (see 1.2.2.1 and 4.5.2)		P
L.1	Typewriters		N
L.2	Adding machines and cash registers		N
L.3	Erasers		N
L.4	Pencil sharpeners		N
L.5	Duplicators and copy machines		N
L.6	Motor-operated files		N
L.7	Other business equipment		P

M	ANNEX M, CRITERIA FOR TELEPHONE RINGING SIGNALS (see 2.3.1)		N
M.1	Introduction		N
M.2	Method A		N
M.3	Method B		N
M.3.1	Ringing signal		N
M.3.1.1	Frequency (Hz)		—
M.3.1.2	Voltage (V)		—
M.3.1.3	Cadence; time (s), voltage (V)		—
M.3.1.4	Single fault current (mA)		—
M.3.2	Tripping device and monitoring voltage		N
M.3.2.1	Conditions for use of a tripping device or a monitoring voltage		N
M.3.2.2	Tripping device		N
M.3.2.3	Monitoring voltage (V)		N

N	ANNEX N, IMPULSE TEST GENERATORS (see 1.5.7.2, 1.5.7.3, 2.10.3.9, 6.2.2.1, 7.3.2, 7.4.3 and Clause G.5)		N
N.1	ITU-T impulse test generators		N
N.2	IEC 60065 impulse test generator		N

LVD TEST REPORT

IEC60950_1B - ATTACHMENT			
Clause	Requirement + Test	Result - Remark	Verdict
P	ANNEX P, NORMATIVE REFERENCES		—
Q	ANNEX Q, Voltage dependent resistors (VDRs) (see 1.5.9.1)		N
	a) Preferred climatic categories		N
	b) Maximum continuous voltage		N
	c) Pulse current		N
R	ANNEX R, EXAMPLES OF REQUIREMENTS FOR QUALITY CONTROL PROGRAMMES		N
R.1	Minimum separation distances for unpopulated coated printed boards (see 2.10.6.2)		N
R.2	Reduced clearances (see 2.10.3)		N
S	ANNEX S, PROCEDURE FOR IMPULSE TESTING (see 6.2.2.3)		N
S.1	Test equipment		N
S.2	Test procedure		N
S.3	Examples of waveforms during impulse testing		N
T	ANNEX T, GUIDANCE ON PROTECTION AGAINST INGRESS OF WATER (see 1.1.2)		N
		See separate test report	—
U	ANNEX U, INSULATED WINDING WIRES FOR USE WITHOUT INTERLEAVED INSULATION (see 2.10.5.4)		P
		Approved TIW used in T1 secondary	—
V	ANNEX V, AC POWER DISTRIBUTION SYSTEMS (see 1.6.1)		N
V.1	Introduction		N
V.2	TN power distribution systems		N
W	ANNEX W, SUMMATION OF TOUCH CURRENTS		N
W.1	Touch current from electronic circuits		N
W.1.1	Floating circuits		N
W.1.2	Earthed circuits		N

LVD TEST REPORT

IEC60950_1B - ATTACHMENT			
Clause	Requirement + Test	Result - Remark	Verdict
W.2	Interconnection of several equipments		N
W.2.1	Isolation		N
W.2.2	Common return, isolated from earth		N
W.2.3	Common return, connected to protective earth		N
X	ANNEX X, MAXIMUM HEATING EFFECT IN TRANSFORMER TESTS (see clause C.1)		P
X.1	Determination of maximum input current		P
X.2	Overload test procedure		P
Y	ANNEX Y, ULTRAVIOLET LIGHT CONDITIONING TEST (see 4.3.13.3)		N
Y.1	Test apparatus		N
Y.2	Mounting of test samples		N
Y.3	Carbon-arc light-exposure apparatus		N
Y.4	Xenon-arc light exposure apparatus		N
Z	ANNEX Z, OVERVOLTAGE CATEGORIES (see 2.10.3.2 and Clause G.2)		P
AA	ANNEX AA, MANDREL TEST (see 2.10.5.8)		N
BB	ANNEX BB, CHANGES IN THE SECOND EDITION		—
CC	ANNEX CC, Evaluation of integrated circuit (IC) current limiters		N
CC.1	General		N
CC.2	Test program 1.....		N
CC.3	Test program 2.....		N
DD	ANNEX DD, Requirements for the mounting means of rack-mounted equipment		N
DD.1	General		N
DD.2	Mechanical strength test, variable N.....		N
DD.3	Mechanical strength test, 250N, including end stops.....		N
DD.4	Compliance.....		N

LVD TEST REPORT

IEC60950_1B - ATTACHMENT			
Clause	Requirement + Test	Result - Remark	Verdict
EE	ANNEX EE, Household and home/office document/media shredders		N
EE.1	General		N
EE.2	Markings and instructions		N
	Use of markings or symbols.....:		N
	Information of user instructions, maintenance and/or servicing instructions.....:		N
EE.3	Inadvertent reactivation test.....:		N
EE.4	Disconnection of power to hazardous moving parts:		N
	Use of markings or symbols.....:		N
EE.5	Protection against hazardous moving parts		N
	Test with test finger (Figure 2A)		N
	Test with wedge probe (Figure EE1 and EE2)		N

LVD TEST REPORT

IEC60950_1B - ATTACHMENT			
Clause	Requirement + Test	Result - Remark	Verdict

1.5.1 TABLE: List of critical components					
Object/part No.	Manufacturer/ trademark	Type/model	Technical data	Standard (Edition / year)	Mark(s) of conformity ¹⁾
Metal Enclosure	MANTA	--	min. thickness : 1.5mm	EN 60950-1	Test with appliance
AC Input and output termianl	HEAVY POWER CO LTD	PA14DS	600VAC, 50A, Suitable for 8- 20AWG, 105°C	--	UL E152546
Overcurrent protector (AC breaker)	TOPSTONE CORP	L1-300211802	250VAC, 30A	--	UL E244552
DC Fuse	POSSING ELECTRONIC CO LTD	ATP	30VDC, 40A	EN 60950-1	UL AU2646 & Test with appliance
Internal AC input and ouput lead wire	YONG HAO ELECTRICAL INDUSTRY CO LTD	1015	105°C,600V, 12AWG BRN/BLU/BLK	EN 60950-1	UL E240426 & Test with appliance
VDR (MOV1)	BRIGHTKING (SHENZHEN) CO LTD	471KN14	300VAC, 0,6W 85 °C	--	UL E327997
X capacitor (C87)	FARAD ELECTRONICS CO LTD	PXK2A7W22K4	275VAC, 0,22µF, 85°C	IEC 60384-14	VDE 40014111
Alt.	FARAD	--	275VAC, 0,22µF, 85°C	IEC 60384-14	VDE
Relay (RY1, RY2)	SONG CHUAN PRECISION CO LTD	832A-1C-F-C	250VAC, 30A, followed by 12VDC, 85°C	--	UL E88991
Insulation sheet (internal topside)	SHIN-ETSU CHEMICAL CO LTD	TC-(xxxx)TCI	V-0, 105°C, min, thickness : 0,4mm	EN 60950-1	UL E48923 & Test with appliance
DC Fans (60mm)	ADDA	AD0612UB- A76GL	4,2W, 0,35A	EN 60950-1	TUV R50068602
DC Fans (80mm)	ADDA	AD0812XB- A73GL(T)	6,6W, 0,55A	EN 60950-1	TUV R50068602

LVD TEST REPORT

IEC60950_1B - ATTACHMENT					
Clause	Requirement + Test	Result - Remark	Verdict		
PCB	DAYA BAY	--	2S 2OZ	UL94	UL E198407
Insulation Transformer (TX1)	RONG CHYUAN TECHNOLOGY CORP	41-070189-00G	Class B	EN 60950-1	Test with appliance
Alt.	CLICK TECHNOLOGY CO LTD	41-070189-00G	Class B	EN 60950-1	Test with appliance
Insulation Transformer insulation system	RONG CHYUAN TECHNOLOGY CORP	HIS-8A, SBI4.2	Class B	UL 1446 IEC /EN 60085	UL E199817
Alt.	CLICK TECHNOLOGY CO LTD	HIS-8A, SBI4.2	Class B	UL 1446 IEC /EN 60085	E184138
--Insulation tape	JINGJIANG YAHUA PRESSURE SENSITIVE GLUE CO LTD	PZ	Polyethylene, 130°C	--	UL E165111 & Test with appliance
--Primary winding	SHENZHEN DAYANG INDUSTRY CO LTD	xUEW-NY	Polyurethane, 130°C	--	UL E176101 & Test with appliance
--Secondary winding	SHENZHEN DAYANG INDUSTRY CO LTD	xUEW-NY	Polyurethane, 130°C	--	UL E176101 & Test with appliance
--Bobbin	SUMITOMO BAKELITE CO LTD	PM-9820	V-0, 150°C	--	UL E41429 & Test with appliance
Insulation Transformer (TX2)	CLICK TECHNOLOGY CO LTD	41-070190-00G	Class B	--	Test with appliance
Alt.	RONG CHYUAN TECHNOLOGY CORP	41-070190-00G	Class B	--	Test with appliance
Insulation Transformer insulation system	CLICK TECHNOLOGY CO LTD	HIS-8A, SBI4.2	Class B	UL 1446 IEC /EN 60085	UL E199817

LVD TEST REPORT

IEC60950_1B - ATTACHMENT					
Clause	Requirement + Test	Result - Remark	Verdict		
Alt.	RONG CHYUAN TECHNOLOGY CORP	HIS-8A, SBI4.2	Class B	UL 1446 IEC /EN 60085	E184138
--Insulation tape	JINGJIANG YAHUA PRESSURE SENSITIVE GLUE CO LTD	PZ	Polyethylene, 130°C	--	UL E165111 & Test with appliance
--Primary winding	PACIFIC ELECTRIC WIRE & CABLE (SHENZHEN) CO LTD	UEW/U	Polyurethane, 130°C	--	UL E201757 & Test with appliance
--Secondary winding	PACIFIC ELECTRIC WIRE & CABLE (SHENZHEN) CO LTD	UEW/U	Polyurethane, 130°C	--	UL E201757 & Test with appliance
--Bobbin	KINGBOARD LAMINATES HOLDINGS LTD	KB-6150	130°C	--	UL E123995 & Test with appliance
Insulation Transformer (TX5)	RONG CHYUAN TECHNOLOGY CORP	41-070188-00G	Class B	EN 60950-1	UL E184138 & Test with appliance
Alt.	CLICK TECHNOLOGY CO LTD	41-070188-00G	Class B	EN 60950-1	UL E199817 & Test with appliance
--Insulation tape	JINGJIANG YAHUA PRESSURE SENSITIVE GLUE CO LTD	PZ	Polyethylene, 130°C	--	UL E165111 & Test with appliance
--Primary winding	SHENZHEN DAYANG INDUSTRY CO LTD	xUEW-NY	Polyurethane, 130°C	--	UL E176101 & Test with appliance
--Secondary winding	SHENZHEN DAYANG INDUSTRY CO LTD	xUEW-NY	Polyurethane, 130°C	--	UL E176101 & Test with appliance
--Bobbin	SUMITOMO BAKELITE CO LTD	PM-9820	V-0, 150°C		UL E41429 & Test with appliance

LVD TEST REPORT

IEC60950_1B - ATTACHMENT					
Clause	Requirement + Test			Result - Remark	Verdict
Opto-coupler	Cosmo Electronic Corp	K1010, KPC817	dti = 0,5 mm, int, dcr, = 5,3 mm ext, dcr, = 8,0 mm	IEC 60950-1 IEC 60747-5-2	VDE101347, UL E169586
Heat-shrinkable tube	CHANGYUAN ELECTRONICS (SHENZHEN) CO LTD	CYG-ZHP, CB-HFT, CB-HFT(XY), CYG-MT	VW-1, 125 °C	--	UL E180908 & Test with appliance
Supplementary information:					

LVD TEST REPORT

IEC60950_1B - ATTACHMENT			
Clause	Requirement + Test	Result - Remark	Verdict

1.5.1	TABLE: Opto Electronic Devices	P
Manufacturer.....:		
Type.....:		
Separately tested:		
Bridging insulation.....:		
External creepage distance:		
Internal creepage distance:		
Distance through insulation:		
Tested under the following conditions.....:		
Input.....: /		
Output.....: /		
supplementary information		
The optical coupler have approved by VDE RI: Reinforced insulation.		

LVD TEST REPORT

IEC60950_1B - ATTACHMENT			
Clause	Requirement + Test	Result - Remark	Verdict

1.6.2	TABLE: Electrical data (in normal conditions)						P
U (V)	I (A)	I _{rated} (A)	P (W)	Fuse #	I _{fuse} (A)	Condition/status	
217 V/ 50 H	15.73	20	15.73	3000 VA /2400 W	--	Maximum Normal output Load at 2900 VA/ 2400 W, cosΦ=0.826 High Rate Charging	
230 V/ 50 H	15.08	20	15.08	3000 VA /2400 W	--	Maximum Normal output Load at 2960 VA/ 2390 W, cosΦ=0.810, High Rate Charging	
253 V/ 50 H	14.26	20	14.26	3000 VA /2400 W	--	Maximum Normal output Load at 3030kVA/ 2400 W, cosΦ=0.790, High Rate Charging	
Supplementary information: the Equipment operation at the most unfavorable status							

2.1.1.5 c) 1)	TABLE: max. V, A, VA test					N
Voltage (rated) (V)	Current (rated) (A)	Voltage (max.) (V)	Current (max.) (A)	VA (max.) (VA)		
supplementary information:						

2.1.1.5 c) 2)	TABLE: stored energy			N
Capacitance C (μF)	Voltage U (V)	Energy E (J)		
--	--	--		
--	--	--		
supplementary information:				

LVD TEST REPORT

IEC60950_1B - ATTACHMENT			
Clause	Requirement + Test	Result - Remark	Verdict

2.2	TABLE: evaluation of voltage limiting components in SELV circuits			P
Component (measured between)		Max. voltage (V) (normal operation)		Voltage Limiting Components
		V peak	V d.c.	
RJ45 Terminal		<5	<5	Non
Fault test performed on voltage limiting components		Voltage measured (V) in SELV circuits (V peak or V d.c.)		
--		--		
supplementary information:				

2.5	TABLE: limited power sources			N	
Circuit output tested:					
Measured Uoc (V) with all load circuits disconnected: --					
		I_{sc} (A)		VA	
		Meas.	Limit	Meas.	Limit
Normal condition		--	--	--	--
Single fault:		--	--	--	--
Single fault:		--	--	--	--
Single fault:		--	--	--	--
supplementary information:					
Sc=Short circuit, Oc=Open circuit					

2.10.2	Table: working voltage measurement			P
Location	RMS voltage (V)	Peak voltage (V)	Comments	
TX1 Any two Pins between Pri. and Sec.	Max. 285 Vrms	Max. 540 Vpeak		
TX5 Any two Pins between Pri. and Sec.				
TX1 Any two Pins between U34, U35				
supplementary information:				

LVD TEST REPORT

IEC60950_1B - ATTACHMENT			
Clause	Requirement + Test	Result - Remark	Verdict

2.10.3 and 2.10.4	TABLE: Clearance and creepage distance measurements						P
Clearance (cl) and creepage distance (cr) at/of/between:	U peak (V)	U r.m.s. (V)	Required cl (mm)	cl (mm)	Required cr (mm)	cr (mm)	
Functional:							
L and N	<420	230	2,0	4,2	2,5	4,5	
Basic/supplementary:							
Pri. winding to core of transformer	540	285	2,6	3,4	3,1	3,6	
Sec. winding to core of transformer	540	285	2,6	3,7	3,1	3,8	
Hazardous live to accessible Conductive (Metal enclosure)	540	285	2,6	4,2	3,1	4,3	
Reinforced:							
Pri. winding and Sec. winding of insulation transformer	540	285	5,2	7,6	5,2	7,8	
Pri. and Sec. PWB	540	285	5,2	5,8	5,2	5,9	
Input or output through Optocoupler	540	285	5,2	5,3	6,2	8,0	
Supplementary information:							
1) FI: Functional insulation; BI: Basic insulation; SI: Supplementary insulation; RI: Reinforced insulation. 2) Core of transformer is considering middle part. 3) A force of 10 N is applied to the internal components and 250 N is applied to the enclosure for measuring.							

2.10.5	TABLE: Distance through insulation measurements					P
Distance through insulation (DTI) at/of:	U peak (V)	U rms (V)	Test voltage (V)	Required DTI (mm)	DTI (mm)	
Bobbin of T1	540	285	3000	0,4	Min. 0,75	
Bobbin of T2	540	285	3000	0,4	Min. 0,75	
Opto-coupler (U3)	540	285	3000	0,4	0,4	
. Insulating sheet between Pri. winding and Sec. winding	540	285	3000	2 layers	2 layers	
Supplementary information:						

LVD TEST REPORT

IEC60950_1B - ATTACHMENT									
Clause	Requirement + Test	Result - Remark						Verdict	
4.3.8	TABLE: Batteries								N
The tests of 4.3.8 are applicable only when appropriate battery data is not available		--						--	
Is it possible to install the battery in a reverse polarity position?		--						--	
	Non-rechargeable batteries			Rechargeable batteries					
	Discharging		Un-intentional charging	Charging		Discharging		Reversed charging	
	Meas. current	Manuf. Specs.		Meas. current	Manuf. Specs.	Meas. current	Manuf. Specs.	Meas. current	Manuf. Specs.
Max. current during normal condition	--	--	--	--	--	--	--	--	--
Max. current during fault condition	--	--	--	--	--	--	--	--	--
Test results:								Verdict	
- Chemical leaks		--						--	
- Explosion of the battery		--						--	
- Emission of flame or expulsion of molten metal		--						--	
- Electric strength tests of equipment after completion of tests		--						--	
Supplementary information:									

4.3.8	TABLE: Batteries								N
Battery category.....:		(Lithium, NiMh, NiCad, Lithium Ion ...)							
Manufacturer.....:		--							
Type / model.....:		--							
Voltage.....:		--							
Capacity.....:		mAh							
Tested and Certified by (incl. Ref. No.).....:									
Circuit protection diagram:									

LVD TEST REPORT

IEC60950_1B - ATTACHMENT			
Clause	Requirement + Test	Result - Remark	Verdict

MARKINGS AND INSTRUCTIONS (1.7.12, 1.7.15)

Location of replaceable battery	N/A
Language(s)	English
Close to the battery	N/A
In the servicing instructions	P
In the operating instructions	P

4.5	TABLE: Thermal requirements						P	
	Supply voltage (V)	207	253	--	--	---		
	Ambient T _{min} (°C)	27,7	27,7	--	--	---		
	Ambient T _{max} (°C)	28,7	27,3	--	--	---		
Maximum measured temperature T of part/at::		T (°C)				Allowed T _{max} (°C)		
	Input connector	42,0	42,9	--	--	T105-30		
	Input Lead wire	42,2	42,7	--	--	T105-30		
	X capacitor	41,6	42,2	--	--	T100-30		
	PCB (near REC1)	42,1	48,5	--	--	T130-30		
	Cap. C63	46,1	46,6	--	--	T105-30		
	Optocoupler U35	49,0	51,6	--	--	T100-30		
	TX5 Winding	76,1	88,4	--	--	T130-30		
	PCB (near D21)	45,9	47,8	--	--	T130-30		
	Battery input terminal	40,7	41,7	--	--	T105-30		
	FAN1	41,6	42,5	--	--	T90-30		
	TX2 Winding	49,0	49,7	--	--	T130-30		
	Secondary output wire	31,2	30,9	--	--	T80-30		
	Socket-outlet	31,6	29,8	--	--	40		
	Secondary Switch	33,1	30,4	--	--	55		
	Metal enclosure near T1	39,3	31,4	--	--	40		
Supplementary information:								
Temperature T of winding:		t ₁ (°C)	R ₁ (Ω)	t ₂ (°C)	R ₂ (Ω)	T (°C)	Allowed T _{max} (°C)	Insulation class
		--	--	--	--	--	--	--
		--	--	--	--	--	--	--

LVD TEST REPORT

IEC60950_1B - ATTACHMENT			
Clause	Requirement + Test	Result - Remark	Verdict

Supplementary information:

- The temperatures were measured under worst case normal mode defined in 1.2.2.1 and as described in sub-clause 1.6.2 and at voltages as described above.
- Max operating temperature 55°C specified in manual. The max. temperature limits are calculated according to $T_{max}' = T_{max} - (55 - T_{amb})$.

4.5.5	TABLE: Ball pressure test of thermoplastic parts			P
	Allowed impression diameter (mm)	≤ 2 mm		—
Part	Test temperature (°C)	Impression diameter (mm)		
Input and output terminal	125	Max 1,6		
Bobbin of transformer	125	Max 0,8		
Supplementary information:				

4.7	TABLE: Resistance to fire					P
Part	Manufacturer of material	Type of material	Thickness (mm)	Flammability class	Evidence	
Transformer bobbin (T1, T2)	Chang Chun Plastics Co Ltd	T375J	Min 0,75	V-0	Pass	
PCB	DAYA BAY	--	Min 1,5	V-0	Pass	
Insulation sheet	WANDA-AN	--	Min 0,4	V-0	Pass	
Supplementary information: See table 1.5.1						

5.1	TABLE: touch current measurement			P
Measured between:	Measured (mA)	Limit (mA)	Comments/conditions	
Input terminal (+/-) to enclosure	0,13	3,5	--	
supplementary information:				

5.2	TABLE: Electric strength tests, impulse tests and voltage surge tests			P
Test voltage applied between:	Voltage shape (AC, DC, impulse, surge)	Test voltage (V)	Breakdown Yes / No	

LVD TEST REPORT

IEC60950_1B - ATTACHMENT			
Clause	Requirement + Test	Result - Remark	Verdict
L to N (Remove Fuse) (BI)		DC 2121	No
Primary to SELV (RI)		DC 4240	No
Primary to Ground (BI)		DC 2121	No
Insulation tape of transformer (1 layers)		AC 3000	No
Supplementary information: FI: Functional insulation; BI: Basic insulation; SI: Supplementary insulation; RI: Reinforced insulation.			

5.3	TABLE: Fault condition tests					P
	Ambient temperature (°C)				25,0	—
	Power source for EUT: Manufacturer, model/type, output rating				--	—
Component No.	Fault	Supply voltage (V)	Test time	Fuse #	Input current (A)	Observation
C88	Short circuit	253	55 min	--	14,26	The Building Overcurrent protected device rated 40 A was operated, no damage and no hazard.
Q36 pin c-e (Battery mode)	Short circuit	--	1s	--	9,5	Unit work abnormal, Circuit protection, no much more temperature rise than normal operation, no damage and no hazards.
U5 Pin 1-2	Short circuit	253	5 min	--	14,26 – 0,56	Unit shutdown, Displayed Error Message and no output, recoverable and no hazard
U5 Pin 1-2 (Battery mode)	Short circuit	--	5 min	--	9,5 – 0	Unit shutdown, Displayed Error Message and no output, recoverable and no hazard
U6 Pin 1-2 (Battery mode)	Short circuit	--	1 min	--	9,5 – 0	Unit shutdown, Displayed Error Message and no output, U13, Q1 damaged and unrecoverable, no hazard, Three times repeated with the same result.
TX2 Pin1-5 (Battery mode)	Short circuit	24	2h	--	9,5	Unit work abnormal, no damage and no hazards, Three times repeated with the same result.
Q16 G-C (Battery mode)	Short circuit	24	2h	--	9,5	Unit shutdown, Displayed Error Message and no output, Q16 damaged and unrecoverable, Three times repeated with the same result, no hazard

LVD TEST REPORT

IEC60950_1B - ATTACHMENT						
Clause	Requirement + Test				Result - Remark	Verdict
Battery input	polarity reverse	253	3min	--	9,5-0	Unit protected, Displayed Error Message and no output, no hazard.
Battery input (Battery mode)	polarity reverse	24	1s	--	0	Unit cannot be operated, no hazard.
C76	Short circuit	253	1s	--	0	Unit shut down after short, no hazard,
Block Openning	Block	253	2h	--	14,26	Temperature steady, no damage and no hazard. Max. Temperature of winding: TX5 winding.: 107,1 °C TX2 winding: 72,3 °C
Q20 D-S	Short circuit	253	2h	--	14,26-0	The wall protection device was operated, no damage and no hazard.
Battery terminal	Short circuit	253	2h	--	14,26-0,56	Unit protect, Displayed Error Message and no output, recoverable and no hazard.
Short U34 1-2	Short circuit	253	2h	--	14,26	Unit normal work, temperature steady, test for 7hour, no damage and no hazard.
Short U3843 3 to GND	Short circuit	253	2h	--	14,26	Unit normal work until temperature steady, test for 7hour, no damage and no hazard.
Fan	Block	253	2h	--	14,26	Temperature steady, temperature rise no more than opening blocking, no damage and no hazard.
Supplementary information:						

LVD TEST REPORT

IEC60950_1B - ATTACHMENT							
Clause	Requirement + Test			Result - Remark			Verdict
C.2	TABLE: transformers						P
Loc.	Tested insulation	Working voltage peak / V (2.10.2)	Working voltage rms / V (2.10.2)	Required electric strength (5.2)	Required clearance / mm (2.10.3)	Required creepage distance / mm (2.10.4)	Required distance thr. insul. (2.10.5)
TX1 pri, to sec,	Reinforced insulation	540	285	3000	5,2	6,2	Insulation tape
TX2 pri, to sec,	Reinforced insulation	540	285	3000	5,2	6,2	Insulation tape
TX5 pri, to sec,	Reinforced insulation	540	285	3000	5,2	6,2	Insulation tape
Loc.	Tested insulation			Test voltage / V	Measured clearance / mm	Measured creepage dist. / mm	Measured distance thr. insul. / mm; number of layers
TX1 pri, to sec,	Reinforced insulation			3000	7,6	7,8	2
TX2 pri, to sec,	Reinforced insulation			3000	7,8	7,8	2
TX5 pri, to sec,	Reinforced insulation			3000	7,8	7,8	2
supplementary information: --							

LVD TEST REPORT

IEC60950_1B - ATTACHMENT			
Clause	Requirement + Test	Result - Remark	Verdict

ATTACHMENT TO TEST REPORT IEC 60950-1 EUROPEAN GROUP DIFFERENCES AND NATIONAL DIFFERENCES Information technology equipment – Safety – PART 1: GENERAL REQUIREMENTS	
Differences according to	EN 60950-1:2006/A11:2009/A1:2010/A12:2011
Attachment Form No.	EU_GD_IEC60950_1B_II
Attachment Originator	SGS Fimko Ltd
Master Attachment	Date 2011-08
Copyright © 2011 IEC System for Conformity Testing and Certification of Electrical Equipment (IECEE), Geneva, Switzerland. All rights reserved.	

EN 60950-1:2006/A11:2009/A1:2010/A12:2011 – CENELEC COMMON MODIFICATIONS

IEC 60950-1, GROUP DIFFERENCES (CENELEC common modifications EN)			
Clause	Requirement + Test	Result - Remark	Verdict
Contents	Add the following annexes: Annex ZA (normative) Normative references to international publications with their corresponding European publications Annex ZB (normative) Special national conditions		P
General	Delete all the “country” notes in the reference document (IEC 60950-1:2005) according to the following list: 1.4.8 Note 2 1.5.1 Note 2 & 3 1.5.7.1 Note 1.5.8 Note 2 1.5.9.4 Note 1.7.2.1 Note 4, 5 & 6 2.2.3 Note 2.2.4 Note 2.3.2 Note 2.3.2.1 Note 2 2.3.4 Note 2 2.6.3.3 Note 2 & 3 2.7.1 Note 2.10.3.2 Note 2 2.10.5.13 Note 3 3.2.1.1 Note 3.2.4 Note 3. 2.5.1 Note 2 4.3.6 Note 1 & 2 4.7 Note 4 4.7.2.2 Note 4.7.3.1 Note 2 5.1.7.1 Note 3 & 4 5.3.7 Note 1 6 Note 2 & 5 6.1.2.1 Note 2 6.1.2.2 Note 6.2.2 Note 6.2.2.1 Note 2 6.2.2.2 Note 7.1 Note 3 7.2 Note 7.3 Note 1 & 2 G.2.1 Note 2 Annex H Note 2		P
General (A1:2010)	Delete all the “country” notes in the reference document (IEC 60950-1:2005/A1:2010) according to the following list: 1.5.7.1 Note 6.1.2.1 Note 2 6.2.2.1 Note 2 EE.3 Note		P

LVD TEST REPORT

IEC60950_1B - ATTACHMENT			
Clause	Requirement + Test	Result - Remark	Verdict

IEC 60950-1, GROUP DIFFERENCES (CENELEC common modifications EN)			
Clause	Requirement + Test	Result - Remark	Verdict
1.3.Z1	<p>Add the following subclause:</p> <p>1.3.Z1 Exposure to excessive sound pressure</p> <p>The apparatus shall be so designed and constructed as to present no danger when used for its intended purpose, either in normal operating conditions or under fault conditions, particularly providing protection against exposure to excessive sound pressures from headphones or earphones.</p> <p>NOTE Z1 A new method of measurement is described in EN 50332-1, Sound system equipment: Headphones and earphones associated with portable audio equipment - Maximum sound pressure level measurement methodology and limit considerations - Part 1: General method for "one package equipment", and in EN 50332-2, Sound system equipment: Headphones and earphones associated with portable audio equipment - Maximum sound pressure level measurement methodology and limit considerations - Part 2: Guidelines to associate sets with headphones coming from different manufacturers.</p>		N
(A12:2011)	<p>In EN 60950-1:2006/A12:2011</p> <p>Delete the addition of 1.3.Z1 / EN 60950-1:2006</p> <p>Delete the definition 1.2.3.Z1 / EN 60950-1:2006 /A1:2010</p>		N
1.5.1	<p>Add the following NOTE:</p> <p>NOTE Z1 The use of certain substances in electrical and electronic equipment is restricted within the EU: see Directive 2002/95/EC</p>		N
1.7.2.1 (A1:2010)	<p>In addition, for a PORTABLE SOUND SYSTEM, the instructions shall include a warning that excessive sound pressure from earphones and headphones can cause hearing loss.</p>		N
1.7.2.1 (A12.2011)	<p>In EN 60950-1:2006/A12:2011</p> <p>Delete NOTE Z1 and the addition for Portable Sound System.</p> <p>Add the following clause and annex to the existing standard and amendments.</p>		N
	<p>Zx Protection against excessive sound pressure from personal music players</p>		N

LVD TEST REPORT

IEC60950_1B - ATTACHMENT			
Clause	Requirement + Test	Result - Remark	Verdict

IEC 60950-1, GROUP DIFFERENCES (CENELEC common modifications EN)			
Clause	Requirement + Test	Result - Remark	Verdict
	<p>Zx.1 General This sub-clause specifies requirements for protection against excessive sound pressure from personal music players that are closely coupled to the ear. It also specifies requirements for earphones and headphones intended for use with personal music players.</p> <p>A personal music player is a portable equipment for personal use, that: is designed to allow the user to listen to recorded or broadcast sound or video; and primarily uses headphones or earphones that can be worn in or on or around the ears; and allows the user to walk around while in use.</p> <p>NOTE 1 Examples are hand-held or body-worn portable CD players, MP3 audio players, mobile phones with MP3 type features, PDA's or similar equipment.</p> <p>A personal music player and earphones or headphones intended to be used with personal music players shall comply with the requirements of this sub-clause.</p> <p>The requirements in this sub-clause are valid for music or video mode only.</p> <p>The requirements do not apply: while the personal music player is connected to an external amplifier; or while the headphones or earphones are not used.</p> <p>NOTE 2 An external amplifier is an amplifier which is not part of the personal music player or the listening device, but which is intended to play the music as a standalone music player.</p> <p>The requirements do not apply to: hearing aid equipment and professional equipment;</p> <p>NOTE 3 Professional equipment is equipment sold through special sales channels. All products sold through normal electronics stores are considered not to be professional equipment.</p>		N

LVD TEST REPORT

IEC60950_1B - ATTACHMENT			
Clause	Requirement + Test	Result - Remark	Verdict

IEC 60950-1, GROUP DIFFERENCES (CENELEC common modifications EN)			
Clause	Requirement + Test	Result - Remark	Verdict
	<p>analogue personal music players (personal music players without any kind of digital processing of the sound signal) that are brought to the market before the end of 2015.</p> <p>NOTE 4 This exemption has been allowed because this technology is falling out of use and it is expected that within a few years it will no longer exist. This exemption will not be extended to other technologies.</p> <p>For equipment which is clearly designed or intended for use by young children, the limits of EN 71-1 apply.</p>		N
	<p>Zx.2 Equipment requirements</p> <p>No safety provision is required for equipment that complies with the following:</p> <p>equipment provided as a package (personal music player with its listening device), where the acoustic output $L_{Aeq,T}$ is ≤ 85 dBA measured while playing the fixed "programme simulation noise" as described in EN 50332-1; and</p> <p>a personal music player provided with an analogue electrical output socket for a listening device, where the electrical output is ≤ 27 mV measured as described in EN 50332-2, while playing the fixed "programme simulation noise" as described in EN 50332-1.</p> <p>NOTE 1 Wherever the term acoustic output is used in this clause, the 30 s A-weighted equivalent sound pressure level $L_{Aeq,T}$ is meant. See also Zx.5 and Annex Zx.</p> <p>All other equipment shall:</p> <p>a) protect the user from unintentional acoustic outputs exceeding those mentioned above; and</p> <p>b) have a standard acoustic output level not exceeding those mentioned above, and automatically return to an output level not exceeding those mentioned above when the power is switched off; and</p>		N

LVD TEST REPORT

IEC60950_1B - ATTACHMENT			
Clause	Requirement + Test	Result - Remark	Verdict

IEC 60950-1, GROUP DIFFERENCES (CENELEC common modifications EN)			
Clause	Requirement + Test	Result - Remark	Verdict
	<p>c) provide a means to actively inform the user of the increased sound pressure when the equipment is operated with an acoustic output exceeding those mentioned above. Any means used shall be acknowledged by the user before activating a mode of operation which allows for an acoustic output exceeding those mentioned above. The acknowledgement does not need to be repeated more than once every 20 h of cumulative listening time; and</p> <p>NOTE 2 Examples of means include visual or audible signals. Action from the user is always required.</p> <p>NOTE 3 The 20 h listening time is the accumulative listening time, independent how often and how long the personal music player has been switched off.</p> <p>d) have a warning as specified in Zx.3; and</p> <p>e) not exceed the following:</p> <ol style="list-style-type: none"> 1) equipment provided as a package (player with its listening device), the acoustic output shall be ≤ 100 dBA measured while playing the fixed "programme simulation noise" described in EN 50332-1; and 2) a personal music player provided with an analogue electrical output socket for a listening device, the electrical output shall be ≤ 150 mV measured as described in EN 50332-2, while playing the fixed "programme simulation noise" described in EN 50332-1. <p>For music where the average sound pressure (long term $L_{Aeq,T}$) measured over the duration of the song is lower than the average produced by the programme simulation noise, the warning does not need to be given as long as the average sound pressure of the song is below the basic limit of 85 dBA. In this case T becomes the duration of the song.</p> <p>NOTE 4 Classical music typically has an average sound pressure (long term $L_{Aeq,T}$) which is much lower than the average programme simulation noise. Therefore, if the player is capable to analyse the song and compare it with the programme simulation noise, the warning does not need to be given as long as the average sound pressure of the song is below the basic limit of 85 dBA.</p> <p>For example, if the player is set with the programme simulation noise to 85 dBA, but the average music level of the song is only 65 dBA, there is no need to give a warning or ask an acknowledgement as long as the average sound level of the song is not above the basic limit of 85 dBA.</p>		N

LVD TEST REPORT

IEC60950_1B - ATTACHMENT			
Clause	Requirement + Test	Result - Remark	Verdict

IEC 60950-1, GROUP DIFFERENCES (CENELEC common modifications EN)			
Clause	Requirement + Test	Result - Remark	Verdict
	<p>Zx.3 Warning The warning shall be placed on the equipment, or on the packaging, or in the instruction manual and shall consist of the following: the symbol of Figure 1 with a minimum height of 5 mm; and the following wording, or similar: "To prevent possible hearing damage, do not listen at high volume levels for long periods."</p>  <p>Figure 1 – Warning label (IEC 60417-6044)</p> <p>Alternatively, the entire warning may be given through the equipment display during use, when the user is asked to acknowledge activation of the higher level.</p>		N
	<p>Zx.4 Requirements for listening devices (headphones and earphones)</p>		N
	<p>Zx.4.1 Wired listening devices with analogue input With 94 dBA sound pressure output $L_{Aeq,T}$, the input voltage of the fixed "programme simulation noise" described in EN 50332-2 shall be ≥ 75 mV. This requirement is applicable in any mode where the headphones can operate (active or passive), including any available setting (for example built-in volume level control). NOTE The values of 94 dBA – 75 mV correspond with 85dBA – 27 mV and 100 dBA – 150 mV.</p>		N

LVD TEST REPORT

IEC60950_1B - ATTACHMENT			
Clause	Requirement + Test	Result - Remark	Verdict

IEC 60950-1, GROUP DIFFERENCES (CENELEC common modifications EN)			
Clause	Requirement + Test	Result - Remark	Verdict
	<p>Zx.4.2 Wired listening devices with digital input With any playing device playing the fixed “programme simulation noise” described in EN 50332-1 (and respecting the digital interface standards, where a digital interface standard exists that specifies the equivalent acoustic level), the acoustic output $L_{Aeq,T}$ of the listening device shall be ≤ 100 dBA.</p> <p>This requirement is applicable in any mode where the headphones can operate, including any available setting (for example built-in volume level control, additional sound feature like equalization, etc.).</p> <p>NOTE An example of a wired listening device with digital input is a USB headphone.</p>		N
	<p>Zx.4.3 Wireless listening devices In wireless mode: with any playing and transmitting device playing the fixed programme simulation noise described in EN 50332-1; and respecting the wireless transmission standards, where an air interface standard exists that specifies the equivalent acoustic level; and with volume and sound settings in the listening device (for example built-in volume level control, additional sound feature like equalization, etc.) set to the combination of positions that maximize the measured acoustic output for the abovementioned programme simulation noise, the acoustic output $L_{Aeq,T}$ of the listening device shall be ≤ 100 dBA.</p> <p>NOTE An example of a wireless listening device is a Bluetooth headphone.</p>		N
	<p>Zx.5 Measurement methods Measurements shall be made in accordance with EN 50332-1 or EN 50332-2 as applicable. Unless stated otherwise, the time interval T shall be 30 s.</p> <p>NOTE Test method for wireless equipment provided without listening device should be defined.</p>		N

LVD TEST REPORT

IEC60950_1B - ATTACHMENT			
Clause	Requirement + Test	Result - Remark	Verdict

IEC 60950-1, GROUP DIFFERENCES (CENELEC common modifications EN)			
Clause	Requirement + Test	Result - Remark	Verdict
2.7.1	<p>Replace the subclause as follows:</p> <p>Basic requirements</p> <p>To protect against excessive current, short-circuits and earth faults in PRIMARY CIRCUITS, protective devices shall be included either as integral parts of the equipment or as parts of the building installation, subject to the following, a), b) and c):</p> <p>a) except as detailed in b) and c), protective devices necessary to comply with the requirements of 5.3 shall be included as parts of the equipment;</p> <p>b) for components in series with the mains input to the equipment such as the supply cord, appliance coupler, r.f.i. filter and switch, short-circuit and earth fault protection may be provided by protective devices in the building installation;</p>		N
	<p>c) it is permitted for PLUGGABLE EQUIPMENT TYPE B or PERMANENTLY CONNECTED EQUIPMENT, to rely on dedicated overcurrent and short-circuit protection in the building installation, provided that the means of protection, e.g. fuses or circuit breakers, is fully specified in the installation instructions.</p> <p>If reliance is placed on protection in the building installation, the installation instructions shall so state, except that for PLUGGABLE EQUIPMENT TYPE A the building installation shall be regarded as providing protection in accordance with the rating of the wall socket outlet.</p>		N
2.7.2	This subclause has been declared 'void'.		N
3.2.3	Delete the NOTE in Table 3A, and delete also in this table the conduit sizes in parentheses.		N

LVD TEST REPORT

IEC60950_1B - ATTACHMENT									
Clause	Requirement + Test	Result - Remark	Verdict						
IEC 60950-1, GROUP DIFFERENCES (CENELEC common modifications EN)									
Clause	Requirement + Test	Result - Remark	Verdict						
3.2.5.1	<p>Replace "60245 IEC 53" by "H05 RR-F"; "60227 IEC 52" by "H03 VV-F or H03 VVH2-F"; "60227 IEC 53" by "H05 VV-F or H05 VVH2-F2".</p> <p>In Table 3B, replace the first four lines by the following:</p> <table border="0"> <tr> <td>Up to and including 6 </td> <td>0,75^{a)} </td> </tr> <tr> <td>Over 6 up to and including 10 </td> <td>(0,75)^{b)} 1,0 </td> </tr> <tr> <td>Over 10 up to and including 16 </td> <td>(1,0)^{c)} 1,5 </td> </tr> </table> <p>In the conditions applicable to Table 3B delete the words "in some countries" in condition^{a)}.</p> <p>In NOTE 1, applicable to Table 3B, delete the second sentence.</p>	Up to and including 6	0,75 ^{a)}	Over 6 up to and including 10	(0,75) ^{b)} 1,0	Over 10 up to and including 16	(1,0) ^{c)} 1,5		N
Up to and including 6	0,75 ^{a)}								
Over 6 up to and including 10	(0,75) ^{b)} 1,0								
Over 10 up to and including 16	(1,0) ^{c)} 1,5								
3.3.4	<p>In Table 3D, delete the fourth line: conductor sizes for 10 to 13 A, and replace with the following:</p> <table border="0"> <tr> <td>Over 10 up to and including 16 </td> <td>1,5 to 2,5 </td> <td>1,5 to 4 </td> </tr> </table> <p>Delete the fifth line: conductor sizes for 13 to 16 A</p>	Over 10 up to and including 16	1,5 to 2,5	1,5 to 4		N			
Over 10 up to and including 16	1,5 to 2,5	1,5 to 4							
4.3.13.6 (A1:2010)	<p>Replace the existing NOTE by the following:</p> <p>NOTE Z1 Attention is drawn to:</p> <p>1999/519/EC: Council Recommendation on the limitation of exposure of the general public to electromagnetic fields 0 Hz to 300 GHz, and</p> <p>2006/25/EC: Directive on the minimum health and safety requirements regarding the exposure of workers to risks arising from physical agents (artificial optical radiation).</p>		N						
	<p>Standards taking into account mentioned Recommendation and Directive which demonstrate compliance with the applicable EU Directive are indicated in the OJEC.</p>		N						
Annex H	<p>Replace the last paragraph of this annex by:</p> <p>At any point 10 cm from the surface of the OPERATOR ACCESS AREA, the dose rate shall not exceed 1 µSv/h (0,1 mR/h) (see NOTE). Account is taken of the background level.</p> <p>Replace the notes as follows:</p> <p>NOTE These values appear in Directive 96/29/Euratom.</p> <p>Delete NOTE 2.</p>		N						

LVD TEST REPORT

IEC60950_1B - ATTACHMENT			
Clause	Requirement + Test	Result - Remark	Verdict

IEC 60950-1, GROUP DIFFERENCES (CENELEC common modifications EN)			
Clause	Requirement + Test	Result - Remark	Verdict
Bibliography	Additional EN standards.		—

ZA	NORMATIVE REFERENCES TO INTERNATIONAL PUBLICATIONS WITH THEIR CORRESPONDING EUROPEAN PUBLICATIONS		—
-----------	--	--	---

ZB ANNEX (normative) SPECIAL NATIONAL CONDITIONS (EN)			
Clause	Requirement + Test	Result - Remark	Verdict
1.2.4.1	In Denmark , certain types of Class I appliances (see 3.2.1.1) may be provided with a plug not establishing earthing conditions when inserted into Danish socket-outlets.		N
1.2.13.14	In Norway and Sweden , for requirements see 1.7.2.1 and 7.3 of this annex.		N
1.5.7.1	In Finland, Norway and Sweden , resistors bridging BASIC INSULATION in CLASS I PLUGGABLE EQUIPMENT TYPE A must comply with the requirements in 1.5.7.1. In addition when a single resistor is used, the resistor must withstand the resistor test in 1.5.7.2.		N
1.5.8	In Norway , due to the IT power system used (see annex V, Figure V.7), capacitors are required to be rated for the applicable line-to-line voltage (230 V).		N
1.5.9.4	In Finland, Norway and Sweden , the third dashed sentence is applicable only to equipment as defined in 6.1.2.2 of this annex.		N

LVD TEST REPORT

IEC60950_1B - ATTACHMENT			
Clause	Requirement + Test	Result - Remark	Verdict

ZB ANNEX (normative) SPECIAL NATIONAL CONDITIONS (EN)			
Clause	Requirement + Test	Result - Remark	Verdict
1.7.2.1	<p>In Finland, Norway and Sweden, CLASS I PLUGGABLE EQUIPMENT TYPE A intended for connection to other equipment or a network shall, if safety relies on connection to protective earth or if surge suppressors are connected between the network terminals and accessible parts, have a marking stating that the equipment must be connected to an earthed mains socket-outlet.</p> <p>The marking text in the applicable countries shall be as follows:</p> <p>In Finland: "Laite on liitettävä suojakoskettimilla varustettuun pistorasiaan"</p> <p>In Norway: "Apparatet må tilkoples jordet stikkontakt"</p> <p>In Sweden: "Apparaten skall anslutas till jordat uttag"</p> <p>In Norway and Sweden, the screen of the cable distribution system is normally not earthed at the entrance of the building and there is normally no equipotential bonding system within the building. Therefore the protective earthing of the building installation need to be isolated from the screen of a cable distribution system.</p> <p>It is however accepted to provide the insulation external to the equipment by an adapter or an interconnection cable with galvanic isolator, which may be provided by e.g. a retailer.</p> <p>The user manual shall then have the following or similar information in Norwegian and Swedish language respectively, depending on in what country the equipment is intended to be used in:</p> <p>"Equipment connected to the protective earthing of the building installation through the mains connection or through other equipment with a connection to protective earthing – and to a cable distribution system using coaxial cable, may in some circumstances create a fire hazard. Connection to a cable distribution system has therefore to be provided through a device providing electrical isolation below a certain frequency range (galvanic isolator, see EN 60728-11)."</p>		N

LVD TEST REPORT

IEC60950_1B - ATTACHMENT			
Clause	Requirement + Test	Result - Remark	Verdict
ZB ANNEX (normative)			
SPECIAL NATIONAL CONDITIONS (EN)			
Clause	Requirement + Test	Result - Remark	Verdict
	<p>NOTE In Norway, due to regulation for installations of cable distribution systems, and in Sweden, a galvanic isolator shall provide electrical insulation below 5 MHz. The insulation shall withstand a dielectric strength of 1,5 kV r.m.s., 50 Hz or 60 Hz, for 1 min.</p> <p>Translation to Norwegian (the Swedish text will also be accepted in Norway): "Utstyr som er koplet til beskyttelsesjord via nettplugg og/eller via annet jordtilkoplet utstyr – og er tilkoplet et kabel-TV nett, kan forårsake brannfare. For å unngå dette skal det ved tilkopling av utstyret til kabel-TV nettet installeres en galvanisk isolator mellom utstyret og kabel- TV nettet." Translation to Swedish: "Utrustning som är kopplad till skyddsjord via jordat vägguttag och/eller via annan utrustning och samtidigt är kopplad till kabel-TV nät kan i vissa fall medföra risk för brand. För att undvika detta skall vid anslutning av utrustningen till kabel-TV nät galvanisk isolator finnas mellan utrustningen och kabel-TV nätet."</p>		N
1.7.5	<p>In Denmark, socket-outlets for providing power to other equipment shall be in accordance with the Heavy Current Regulations, Section 107-2-D1, Standard Sheet DK 1-3a, DK 1-5a or DK 1-7a, when used on Class I equipment. For STATIONARY EQUIPMENT the socket-outlet shall be in accordance with Standard Sheet DK 1-1b or DK 1-5a.</p> <p>For CLASS II EQUIPMENT the socket outlet shall be in accordance with Standard Sheet DKA 1-4a.</p>		N
2.2.4	In Norway , for requirements see 1.7.2.1, 6.1.2.1 and 6.1.2.2 of this annex.		N
2.3.2	In Finland, Norway and Sweden there are additional requirements for the insulation. See 6.1.2.1 and 6.1.2.2 of this annex.		N
2.3.4	In Norway , for requirements see 1.7.2.1, 6.1.2.1 and 6.1.2.2 of this annex.		N
2.6.3.3	In the United Kingdom , the current rating of the circuit shall be taken as 13 A, not 16 A.		N

LVD TEST REPORT

IEC60950_1B - ATTACHMENT			
Clause	Requirement + Test	Result - Remark	Verdict

ZB ANNEX (normative) SPECIAL NATIONAL CONDITIONS (EN)			
Clause	Requirement + Test	Result - Remark	Verdict
2.7.1	In the United Kingdom , to protect against excessive currents and short-circuits in the PRIMARY CIRCUIT of DIRECT PLUG-IN EQUIPMENT, tests according to 5.3 shall be conducted, using an external protective device rated 30 A or 32 A. If these tests fail, suitable protective devices shall be included as integral parts of the DIRECT PLUG-IN EQUIPMENT, so that the requirements of 5.3 are met.		N
2.10.5.13	In Finland, Norway and Sweden , there are additional requirements for the insulation, see 6.1.2.1 and 6.1.2.2 of this annex.		N
3.2.1.1	<p>In Switzerland, supply cords of equipment having a RATED CURRENT not exceeding 10 A shall be provided with a plug complying with SEV 1011 or IEC 60884-1 and one of the following dimension sheets:</p> <p>SEV 6532-2.1991 Plug Type 15 3P+N+PE 250/400 V, 10 A</p> <p>SEV 6533-2.1991 Plug Type 11 L+N 250 V, 10 A</p> <p>SEV 6534-2.1991 Plug Type 12 L+N+PE 250 V, 10 A</p> <p>In general, EN 60309 applies for plugs for currents exceeding 10 A. However, a 16 A plug and socket-outlet system is being introduced in Switzerland, the plugs of which are according to the following dimension sheets, published in February 1998:</p> <p>SEV 5932-2.1998: Plug Type 25 , 3L+N+PE 230/400 V, 16 A</p> <p>SEV 5933-2.1998: Plug Type 21, L+N, 250 V, 16A</p> <p>SEV 5934-2.1998: Plug Type 23, L+N+PE 250 V, 16 A</p>		N

LVD TEST REPORT

IEC60950_1B - ATTACHMENT			
Clause	Requirement + Test	Result - Remark	Verdict

ZB ANNEX (normative) SPECIAL NATIONAL CONDITIONS (EN)			
Clause	Requirement + Test	Result - Remark	Verdict
3.2.1.1	<p>In Denmark, supply cords of single-phase equipment having a rated current not exceeding 13 A shall be provided with a plug according to the Heavy Current Regulations, Section 107-2-D1.</p> <p>CLASS I EQUIPMENT provided with socket-outlets with earth contacts or which are intended to be used in locations where protection against indirect contact is required according to the wiring rules shall be provided with a plug in accordance with standard sheet DK 2-1a or DK 2-5a.</p> <p>If poly-phase equipment and single-phase equipment having a RATED CURRENT exceeding 13 A is provided with a supply cord with a plug, this plug shall be in accordance with the Heavy Current Regulations, Section 107-2-D1 or EN 60309-2.</p>		N
3.2.1.1	<p>In Spain, supply cords of single-phase equipment having a rated current not exceeding 10 A shall be provided with a plug according to UNE 20315:1994.</p> <p>Supply cords of single-phase equipment having a rated current not exceeding 2,5 A shall be provided with a plug according to UNE-EN 50075:1993.</p> <p>CLASS I EQUIPMENT provided with socket-outlets with earth contacts or which are intended to be used in locations where protection against indirect contact is required according to the wiring rules, shall be provided with a plug in accordance with standard UNE 20315:1994.</p> <p>If poly-phase equipment is provided with a supply cord with a plug, this plug shall be in accordance with UNE-EN 60309-2.</p>		N

LVD TEST REPORT

IEC60950_1B - ATTACHMENT			
Clause	Requirement + Test	Result - Remark	Verdict
ZB ANNEX (normative)			
SPECIAL NATIONAL CONDITIONS (EN)			
Clause	Requirement + Test	Result - Remark	Verdict
3.2.1.1	In the United Kingdom , apparatus which is fitted with a flexible cable or cord and is designed to be connected to a mains socket conforming to BS 1363 by means of that flexible cable or cord and plug, shall be fitted with a 'standard plug' in accordance with Statutory Instrument 1768:1994 - The Plugs and Sockets etc. (Safety) Regulations 1994, unless exempted by those regulations. NOTE 'Standard plug' is defined in SI 1768:1994 and essentially means an approved plug conforming to BS 1363 or an approved conversion plug.		N
3.2.1.1	In Ireland , apparatus which is fitted with a flexible cable or cord and is designed to be connected to a mains socket conforming to I.S. 411 by means of that flexible cable or cord and plug, shall be fitted with a 13 A plug in accordance with Statutory Instrument 525:1997 - National Standards Authority of Ireland (section 28) (13 A Plugs and Conversion Adaptors for Domestic Use) Regulations 1997.		N
3.2.4	In Switzerland , for requirements see 3.2.1.1 of this annex.		N
3.2.5.1	In the United Kingdom , a power supply cord with conductor of 1,25 mm ² is allowed for equipment with a rated current over 10 A and up to and including 13 A.		N
3.3.4	In the United Kingdom , the range of conductor sizes of flexible cords to be accepted by terminals for equipment with a RATED CURRENT of over 10 A up to and including 13 A is: • 1,25 mm ² to 1,5 mm ² nominal cross-sectional area.		N

LVD TEST REPORT

IEC60950_1B - ATTACHMENT			
Clause	Requirement + Test	Result - Remark	Verdict
ZB ANNEX (normative)			
SPECIAL NATIONAL CONDITIONS (EN)			
Clause	Requirement + Test	Result - Remark	Verdict
4.3.6	In the United Kingdom , the torque test is performed using a socket outlet complying with BS 1363 part 1:1995, including Amendment 1:1997 and Amendment 2:2003 and the plug part of DIRECT PLUG-IN EQUIPMENT shall be assessed to BS 1363: Part 1, 12.1, 12.2, 12.3, 12.9, 12.11, 12.12, 12.13, 12.16 and 12.17, except that the test of 12.17 is performed at not less than 125 °C. Where the metal earth pin is replaced by an Insulated Shutter Opening Device (ISOD), the requirements of clauses 22.2 and 23 also apply.		N
4.3.6	In Ireland , DIRECT PLUG-IN EQUIPMENT is known as plug similar devices. Such devices shall comply with Statutory Instrument 526:1997 - National Standards Authority of Ireland (Section 28) (Electrical plugs, plug similar devices and sockets for domestic use) Regulations, 1997.		N
5.1.7.1	In Finland, Norway and Sweden TOUCH CURRENT measurement results exceeding 3,5 mA r.m.s. are permitted only for the following equipment: <ul style="list-style-type: none"> • STATIONARY PLUGGABLE EQUIPMENT TYPE A that <ul style="list-style-type: none"> is intended to be used in a RESTRICTED ACCESS LOCATION where equipotential bonding has been applied, for example, in a telecommunication centre; and has provision for a permanently connected PROTECTIVE EARTHING CONDUCTOR; and is provided with instructions for the installation of that conductor by a SERVICE PERSON; • STATIONARY PLUGGABLE EQUIPMENT TYPE B; • STATIONARY PERMANENTLY CONNECTED EQUIPMENT. 		N

LVD TEST REPORT

IEC60950_1B - ATTACHMENT			
Clause	Requirement + Test	Result - Remark	Verdict

ZB ANNEX (normative) SPECIAL NATIONAL CONDITIONS (EN)			
Clause	Requirement + Test	Result - Remark	Verdict
6.1.2.1 (A1:2010)	<p>In Finland, Norway and Sweden, add the following text between the first and second paragraph of the compliance clause:</p> <p>If this insulation is solid, including insulation forming part of a component, it shall at least consist of either</p> <ul style="list-style-type: none"> - two layers of thin sheet material, each of which shall pass the electric strength test below, or - one layer having a distance through insulation of at least 0,4 mm, which shall pass the electric strength test below. <p>Alternatively for components, there is no distance through insulation requirements for the insulation consisting of an insulating compound completely filling the casing, so that CLEARANCES and CREEPAGE DISTANCES do not exist, if the component passes the electric strength test in accordance with the compliance clause below and in addition</p> <ul style="list-style-type: none"> - passes the tests and inspection criteria of 2.10.11 with an electric strength test of 1,5 kV multiplied by 1,6 (the electric strength test of 2.10.10 shall be performed using 1,5 kV), and - is subject to ROUTINE TESTING for electric strength during manufacturing, using a test voltage of 1,5 kV. 		N

LVD TEST REPORT

IEC60950_1B - ATTACHMENT			
Clause	Requirement + Test	Result - Remark	Verdict
ZB ANNEX (normative)			
SPECIAL NATIONAL CONDITIONS (EN)			
Clause	Requirement + Test	Result - Remark	Verdict
	<p>It is permitted to bridge this insulation with an optocoupler complying with 2.10.5.4 b).</p> <p>It is permitted to bridge this insulation with a capacitor complying with EN 60384-14:2005, subclass Y2.</p> <p>A capacitor classified Y3 according to EN 60384-14:2005, may bridge this insulation under the following conditions:</p> <ul style="list-style-type: none"> - the insulation requirements are satisfied by having a capacitor classified Y3 as defined by EN 60384-14, which in addition to the Y3 testing, is tested with an impulse test of 2,5 kV defined in EN 60950-1:2006, 6.2.2.1; - the additional testing shall be performed on all the test specimens as described in EN 60384-14: - the impulse test of 2,5 kV is to be performed before the endurance test in EN 60384-14, in the sequence of tests as described in EN 60384-14. 		N
6.1.2.2	In Finland, Norway and Sweden , the exclusions are applicable for PERMANENTLY CONNECTED EQUIPMENT, PLUGGABLE EQUIPMENT TYPE B and equipment intended to be used in a RESTRICTED ACCESS LOCATION where equipotential bonding has been applied, e.g. in a telecommunication centre, and which has provision for a permanently connected PROTECTIVE EARTHING CONDUCTOR and is provided with instructions for the installation of that conductor by a SERVICE PERSON.		N
7.2	In Finland, Norway and Sweden , for requirements see 6.1.2.1 and 6.1.2.2 of this annex. The term TELECOMMUNICATION NETWORK in 6.1.2 being replaced by the term CABLE DISTRIBUTION SYSTEM.		N
7.3	In Norway and Sweden , for requirements see 1.2.13.14 and 1.7.2.1 of this annex.		N

LVD TEST REPORT

IEC60950_1B - ATTACHMENT			
Clause	Requirement + Test	Result - Remark	Verdict

ZB ANNEX (normative)			
SPECIAL NATIONAL CONDITIONS (EN)			
Clause	Requirement + Test	Result - Remark	Verdict
7.3	In Norway , for installation conditions see EN 60728-11:2005.		N

LVD TEST REPORT

Appendix 1: Photo documentation



Fig.1- General view



Fig.1- Terminal Cover view

LVD TEST REPORT

Appendix 1: Photo documentation



Fig.3- Side view

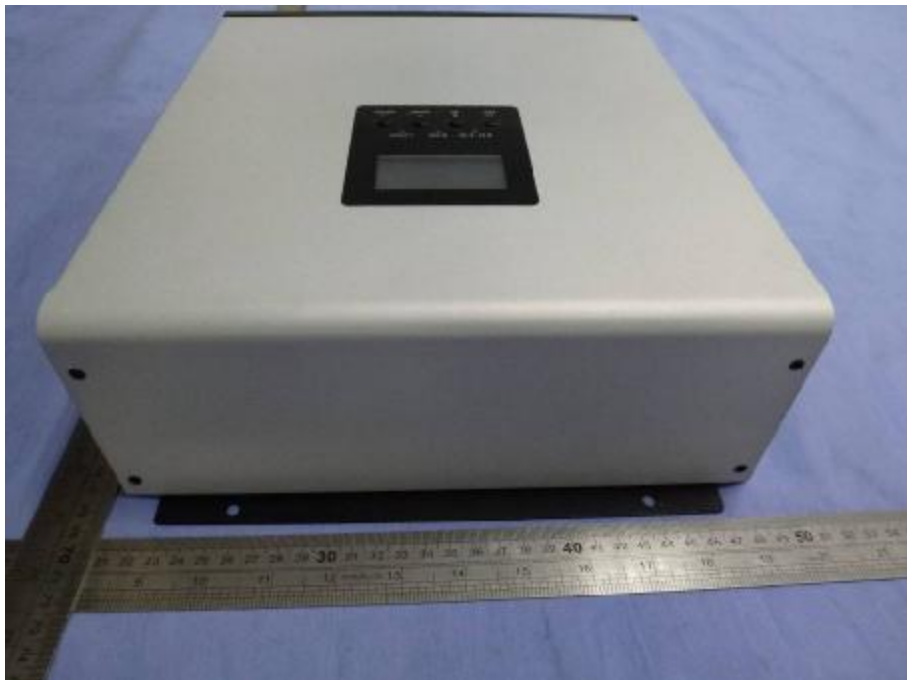

Fig.4- Back view

LVD TEST REPORT

Appendix 1: Photo documentation



Fig.5- Bottom view (no opening)



Fig.6- Internal view

LVD TEST REPORT

Appendix 1: Photo documentation



Fig.7- Internal view



Fig.8- Internal view

LVD TEST REPORT

Appendix 1: Photo documentation



Fig.9- Insulation barrier sheet view

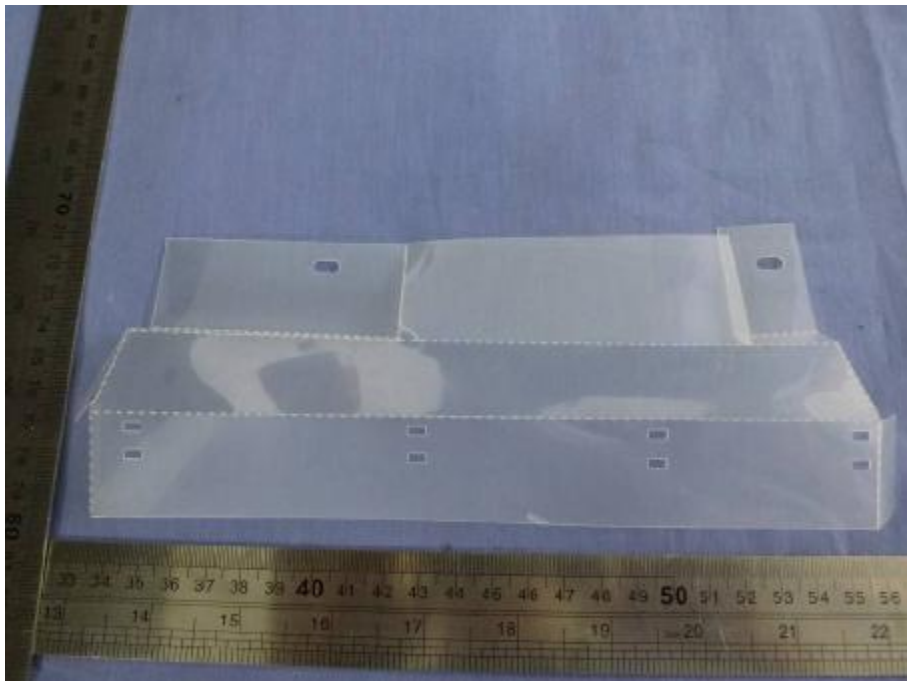

Fig.10- Insulation barrier sheet view

LVD TEST REPORT

Appendix 1: Photo documentation



Fig.11- Internal view



Fig.12- Fan view

LVD TEST REPORT

Appendix 1: Photo documentation



Fig.13- PCB board view

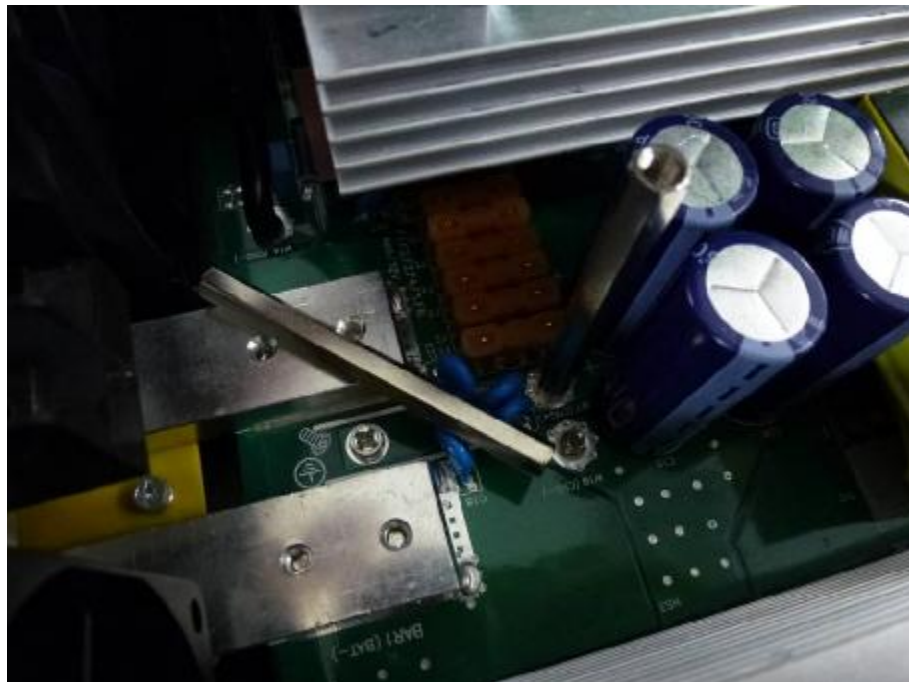

Fig.14- Internal view

LVD TEST REPORT

Appendix 1: Photo documentation



Fig.15- Terminal view



Fig.16- Internal view

LVD TEST REPORT

Appendix 1: Photo documentation

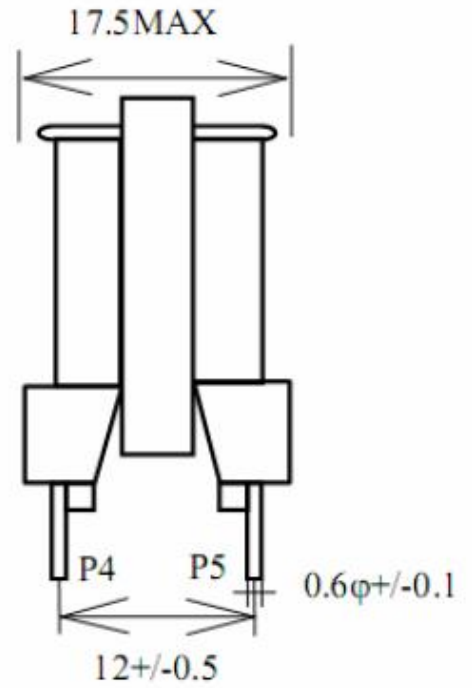
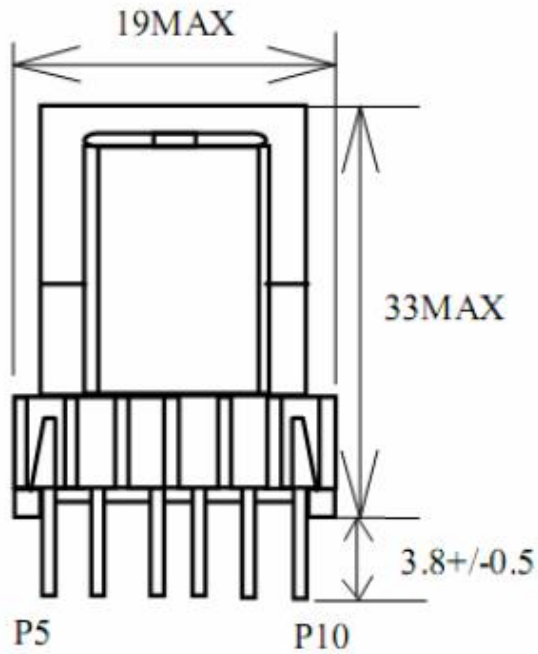

Fig.17- Input and output terminals view

LVD TEST REPORT

Appendix 2: Transformer Specification

Transformer TX1 specification:



- 1) CORE TAPE 3Ts.
- 2) 外包装盒需贴绿色环保标签.

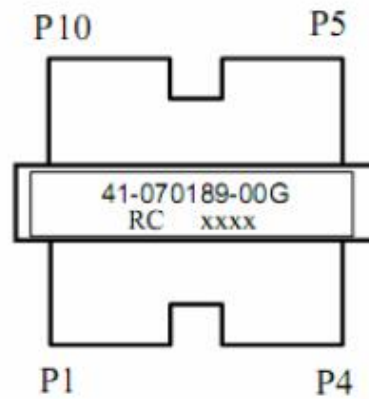
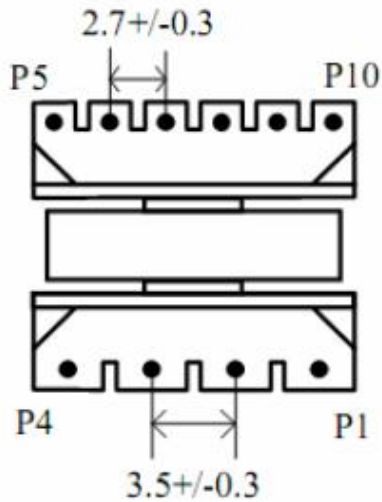

LVD TEST REPORT

Appendix 2: Transformer Specification

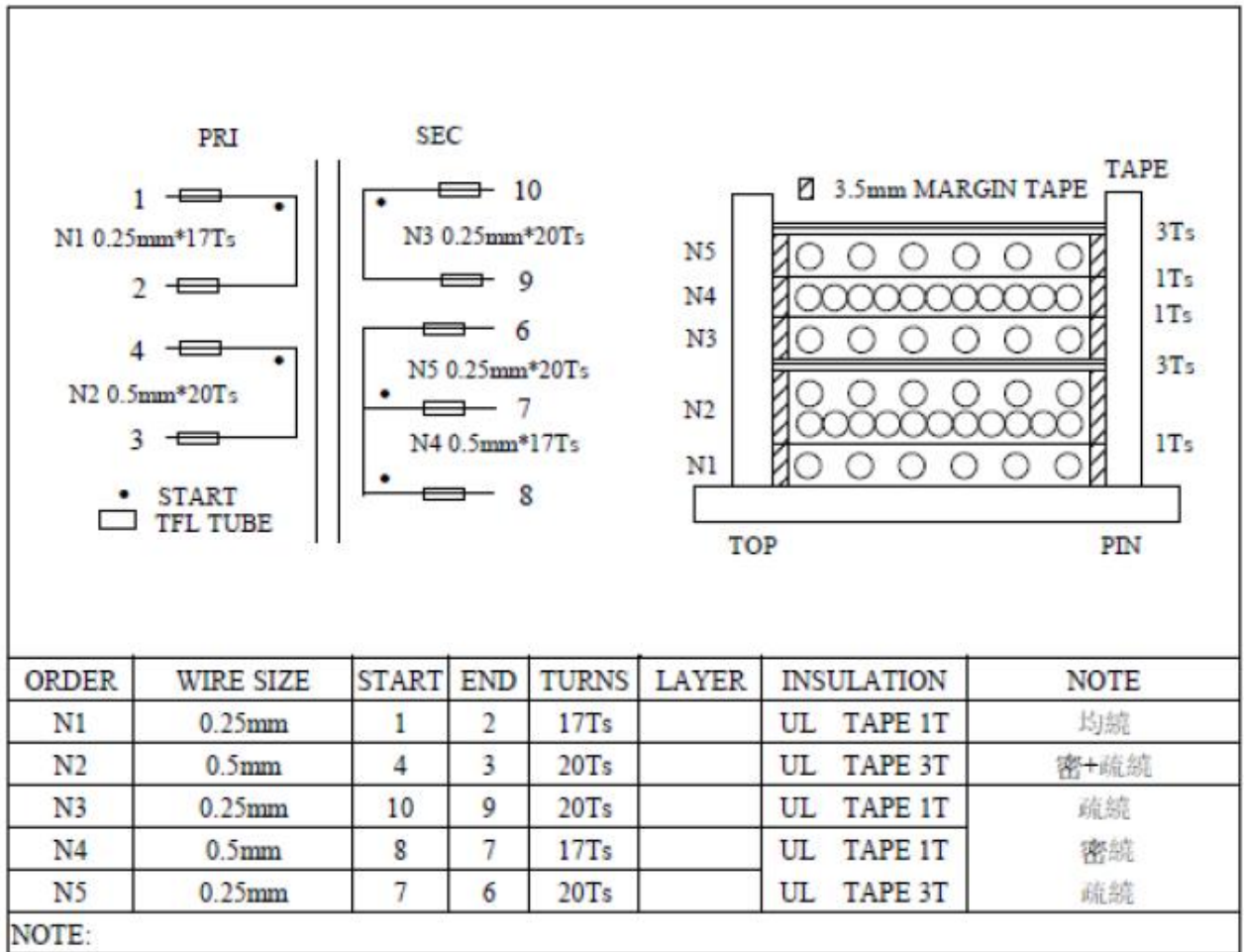

LVD TEST REPORT

Appendix 2: Transformer Specification

Transformer TX2 specification:

MECHANICAL DIMENSION: (UNIT:mm)

DMEGC 青色点
TDG 橙色点

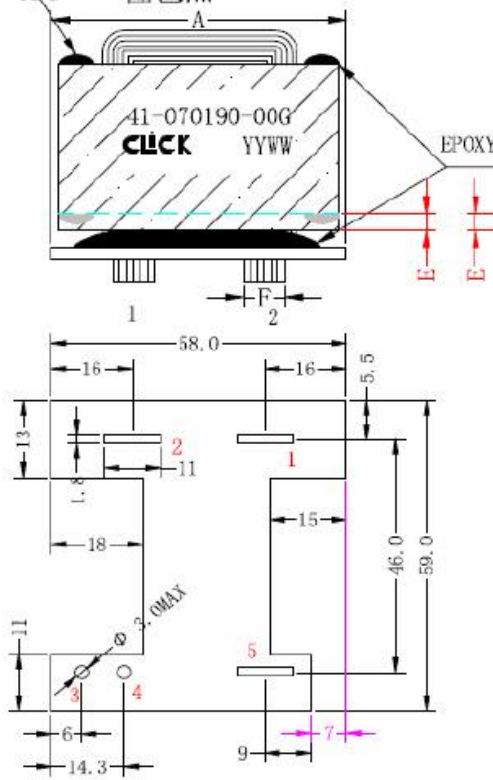

顶视图

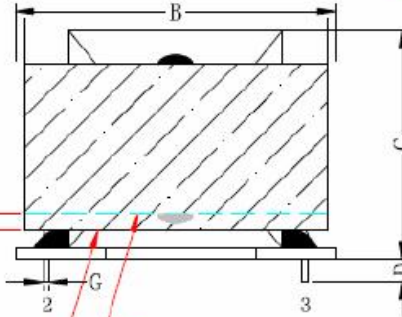

DIMENSION: (mm)

- A: 59.0 MAX
- B: 62.0 MAX
- C: 61.0 MAX
- D: 3.8 ± 0.5
- E: 3.0 MIN
- F: 11.0 MAX
- G: 1.80 MAX

铁芯底部平面
铁芯胶带要超出铁芯底部面3.0mm以上于满足安规需求

REMARK:

1. 铜皮用0.025mm厚的黄色胶带背胶1层，背胶后反折4mm MIN;
2. PIN 3, 4 加套管;
3. 磁芯包3Ts胶带(要超出铁芯底部面3.0mm以上于满足安规需求);
4. 点胶固定铁芯和线圈。

SCHMATIC:

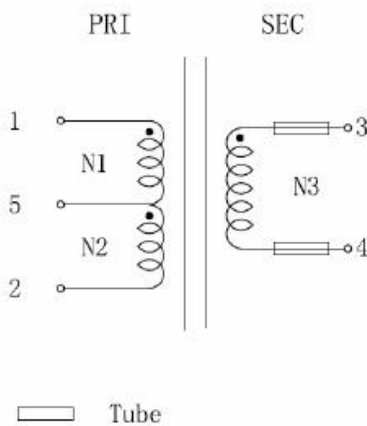

WINDING CONSTRUCTION:

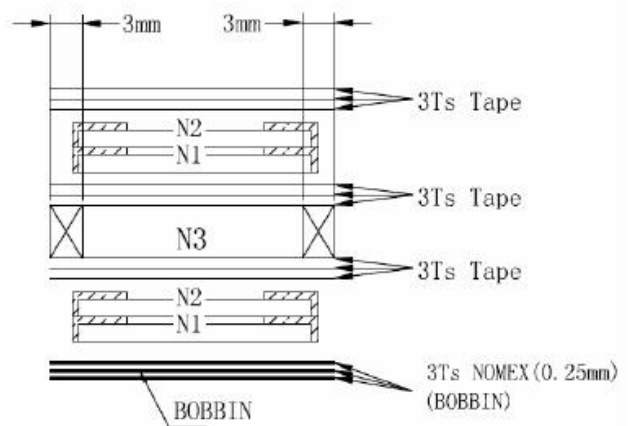

LVD TEST REPORT

Appendix 2: Transformer Specification

料号		41-070190-00G				页次	3
WDG	TERMINAL	WIRE GAUGE	TURNS	TAPE	MARGIN TAPE	REMARKS	
		3Ts NOMEX (0.25mm*36mm)	3				
N1	1-5	0.3*35mm铜皮	2	3		同一铜皮 两端引线Φ1.2*3P 中间引线Φ1.2*3P	
N2	5-2	0.3*35mm铜皮	2				
N3	3-4	2UEW-B Φ0.2*18C*3P	31	3	3.0/3.0mm	多层密绕, 层间胶带1Ts	
N1	1-5	0.3*35mm铜皮	2	3		同一铜皮 两端引线Φ1.2*3P 中间引线Φ1.2*3P	
N2	5-2	0.3*35mm铜皮	2				

LVD TEST REPORT

Appendix 2: Transformer Specification

Transformer TX5 specification:

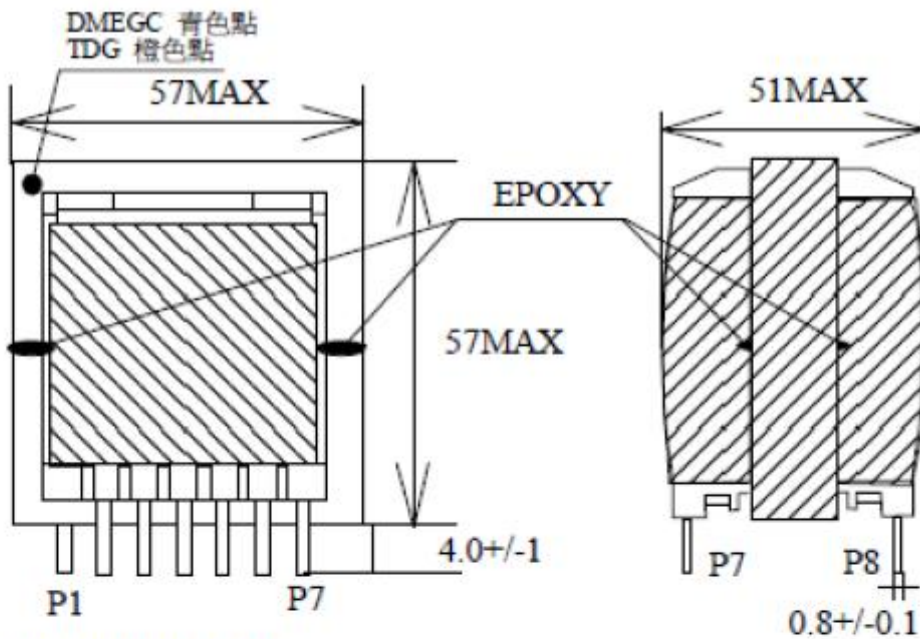

- 1) PIN1.10 CUT OFF.
- 2) CORE TAPE 3Ts.
- 3) PIN端CORE包面3Ts; CORE結合處點EPOXY 固定.
- 4) X抽頭絞合鍍錫后靠近第PIN14側折回線包.防止線包超厚.
- 5) 外包裝盒需貼綠色環保標籤.

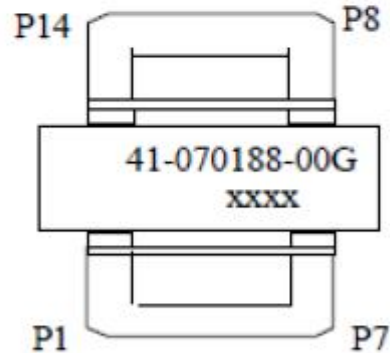
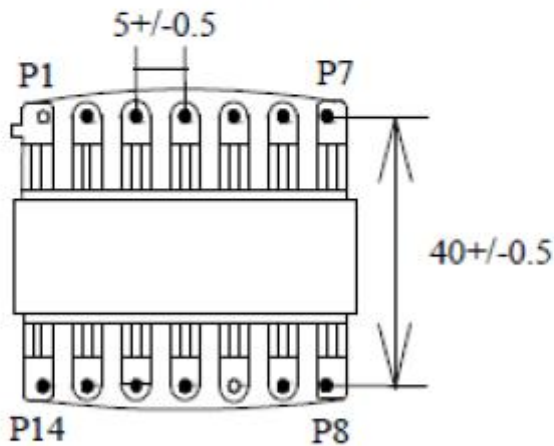
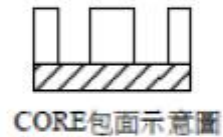

LVD TEST REPORT

Appendix 2: Transformer Specification

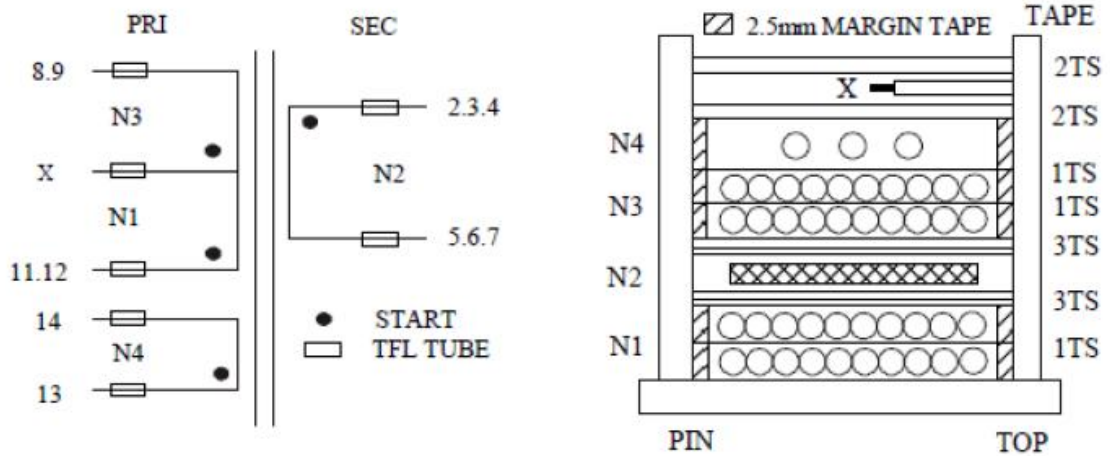

ORDER	WIRE SIZE	START	END	TURNS	LAYER	INSULATION	NOTE
N1	0.2mm*30C*2P	11.12	x	16Ts		UL TAPE 3T	密繞
N2	0.3tp*30mm	2.3.4	5.6.7	6Ts		UL TAPE 3T	中密
N3	0.2mm*30C*2P	X	8.9	17Ts		UL TAPE 1T	密繞
N4	0.3mm	13	14	3Ts		UL TAPE 2T	疏繞

NOTE: 1)N2 為一條背膠銅箔帶,首尾各焊引線 1.0mm*3P.

2)N1.N3 須層間絕緣 1Ts TAPE.

3)X 絞合鍍錫後,待 N4 繞組完成,折回線包內,包 TAPE 2Ts.

*** End of report ***

The test report is effective only with both signature and specialized stamp, The result(s) shown in this report refer only to the sample(s) tested. Without written approval of CTI, this report can't be reproduced except in full.