

# Logitek Electronic Systems

## *Pilot Reference Manual*



Revision 1.5  
Oct 2010

Logitek Electronic Systems, Inc.  
5622 Edgemoor Drive  
Houston, Texas 77081  
USA

**Tel** 877-231-5870  
+1-713-664-4470 (outside U.S. and Canada)  
**Fax** +1-713-664-4479

**Email** [support@logitekaudio.com](mailto:support@logitekaudio.com)  
**Web** [www.logitekaudio.com](http://www.logitekaudio.com)

Contents © 2012 Logitek Electronic Systems, Inc

**Notice**

Every effort has been made to supply complete and accurate information. However, Logitek Electronic Systems, Inc. assumes no responsibility for its use, nor any infringement of patents or other rights of third parties, which would result.

Worldwide rights reserved. Except for your own personal use, no part of this publication may be stored in a retrieval system, transmitted or reproduced in any way, including but not limited to photocopy, photograph, magnetic or other record, without the prior agreement and written permission of Logitek Electronic Systems, Inc.

Logitek, JetStream, and Pilot are trademarks of Logitek Electronic Systems, Inc.

All other trademarks acknowledged.

All specifications are subject to change without notice.



## Document Revisions

| Date           | Revision | Author           | Notes   |
|----------------|----------|------------------|---|
| September 2010 | 0.5      | Paul Dengate     | Preliminary release of Pilot manual   |
| October 2010   | 1.0      | John Davis, CBNT | First release of Pilot manual   |
| April 2012     | 1.5      | John Davis, CBNT | Revised to add support for AE-32 platform, added Mic Live/On Air Tally info |

## Contents

|                                |    |
|--------------------------------|----|
| Document Revisions.....        | 4  |
| Contents 5                     |    |
| 1 Introduction.....            | 6  |
| 2 Unpacking 10                 |    |
| 3 Physical Installation.....   | 11 |
| 4 Configuration.....           | 17 |
| 5 Operation 23                 |    |
| 6 Maintenance.....             | 26 |
| Appendix A Release Notes.....  | 29 |
| Appendix B Specifications..... | 30 |
| Appendix C Pinouts.....        | 32 |
| Two Year Limited Warranty..... | 33 |

# 1 Introduction

## About this Manual

This manual describes the installation and operation of the **Logitek Pilot** control surface.

### Intended Audience

This manual is aimed at Engineers responsible for installing, configuring and supporting a **Logitek Networked Console System** with the *Pilot* surface.

In the context of a system installation, or to become familiar with the entire **Logitek Networked Console System**, the reader should also reference:

- JetStream Reference Manual
- AEConfig Reference Manual
- CommandBuilder Reference Manual

### Manual Conventions

The following conventions are used in this manual:

---

*This text indicates a menu choice to be made, with an arrow separating a multi-level selection, eg Control Panel ➤ Users & Passwords. This can be a menu choice in a Logitek application, or within Windows.*

↪ *Indicates a “see-also” section in this manual, or another Logitek manual.*



The exclamation symbol signifies an important note or critical information.

This text represents a command, script block example, instruction to be typed, or directory path.

 **TIP:** A useful tip from our knowledge base!

## About Pilot

The *Pilot* control surface from **Logitek Electronic Systems** brings you the flexibility of a router based audio console system with the look, feel and easy handling that novice operators will understand, and experienced console operators will appreciate.

The *Pilot* offers full access to the sources available on **Logitek's JetStream** routers, along with simple bus selection and intuitive monitor controls. The *Pilot* is compatible with the **Logitek Audio Engine** provided that the engine has an AE-C6 card with version 3.77 or higher.

The *Pilot* surface can be configured with 6, 12, 18 or 24 Faders. There is also a Monitor Module containing the Monitoring and Selection functions. The module types include:

- **PLT-FADER** **6 Fader Module**
- **PLT-MON** **Monitor Control Module**

In addition, a **Meter Bridge (PLT-MTR)** is available.

The main frame is available in a number of different sizes to accommodate the variety of fader numbers. The frame is designed to be mounted on a desk for semi-permanent installation, but as no cutouts are required it can easily be relocated.



The Pilot UK Console

## System Requirements

*Pilot* is designed to connect to a **Logitek JetStream** running DSP version 4.x. Contact **Logitek Electronic Systems** or your reseller if you are unsure of compatibility, or are adding a *Pilot* surface to a pre-existing **Logitek** facility.

## System Architecture

Put simply, the Pilot surface is just a remote control panel for the JetStream. Unlike traditional analog consoles, no audio passes through the Pilot or its faders (with the exception of the cue speaker audio). The Pilot talks to the JetStream using the Logitek Command Protocol, with all audio processing occurring inside the router.

The mixing, routing and processing of audio is not dependent upon the embedded PC included with the JetNet Audio Networking Module. However, additional functionality, such as macro buttons, scene snapshots, intercoms, delay control and software tools interface to the system using the JetStream Server application that is bundled with the module.

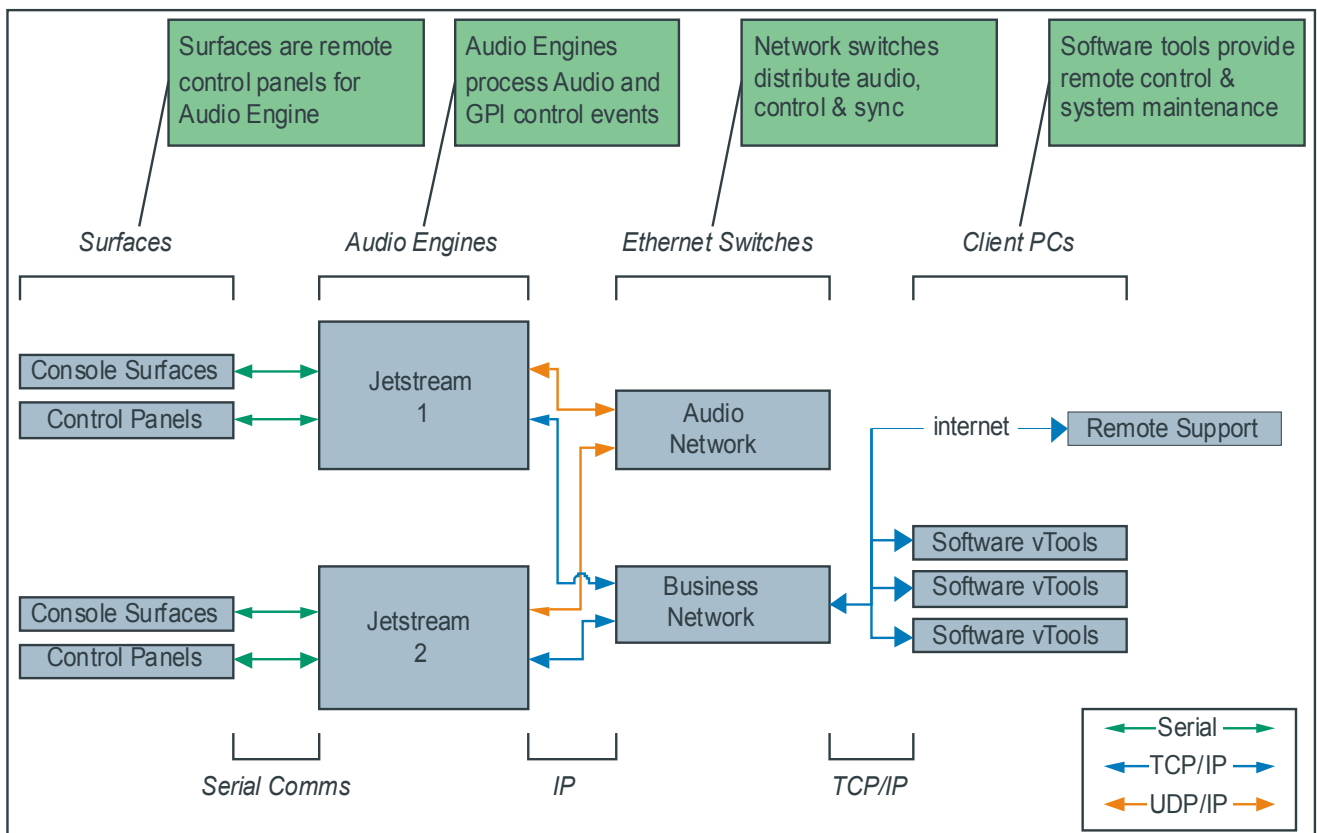

Figure 1 -Logitek System Architecture (v4.x)

## Compatibility Matrix

*Pilot* is designed for use with the **JetStream Router** v4.x and Audio Engine v3.77 and later. The *Pilot* retains compatibility with other surfaces for the majority of its features.

Following is the minimum software release version/date that is required for *Pilot* support.

| Component          | General Support | Additional Features |
|--------------------|-----------------|---------------------|
| JSM-DSP Controller | v1.41           |                     |
| JetStream Server   | v4.0            |                     |
| CommandBuilder     | v3.6            |                     |
| AEConfig           | v3.6            |                     |
| JetSet             | V1.0            |                     |



## 2 Unpacking

This section details what you should do when unpacking your newly arrived *Pilot* surface.

### Parts List

The exact list of parts received will vary depending on your order, but should generally include:

- 1 x *Pilot* Power Supply (external brick-style)
- 1 x fully assembled *Pilot* frame, containing modules as ordered
- 1 x meter bridge assembly (option)

You will receive a parts list with the system that is specific to the modules on your order.

### Unpacking

Carefully unpack the cartons whilst looking for any signs of shipping damage. You may wish to save the shipping cartons until the operation of the system is verified.

Report any damage to the shipping carrier immediately. Verify that the contents of each box match the packing list and report any discrepancies immediately to **Logitek** in writing.

### Contacting Logitek

In the event of a shipping problem, you can contact **Logitek Electronic Systems** in several ways:

|                  |  |
|------------------|--|
| <b>U.S. Mail</b> | Logitek Electronic Systems, Inc.<br>5622 Edgemoor Drive<br>Houston, Texas 77081<br>USA |
| <b>Telephone</b> | 877-231-5870<br>+1-713-664-4470 (outside U.S. and Canada)                              |
| <b>Fax</b>       | +1-713-664-4479  |
| <b>Email</b>     | support@logitekaudio.com   |
| <b>Website</b>   | <a href="http://www.logitekaudio.com">www.logitekaudio.com</a>                         |

Outside of North America, please contact your local Logitek Authorized Dealer for assistance.

## 3 Physical Installation

The *Pilot* surface is designed to be mounted on a desk in a semi-permanent studio installation. The **Meter Bridge**, if optioned, can be screwed to the back of the *Pilot*.

### Power Supply Unit

The **Power Supply Unit** is an external brick-style supply.

Power inlet is via a single IEC connector on the rear of the **Power Supply Unit**. A power cable is supplied only for US installations. International customers may contact their reseller for the supply of power cables if required.

As the power supplies are of switch-mode type, there is no voltage selection required.

### Pilot Frames

A number of *Pilot* frame sizes are available, depending on the total number of faders. Each module takes up either one or two "slots" in the frame. The **Monitor** module occupies half the slot space of a **Fader** module.

The frame will be shipped with the modules connected and fitted as ordered. These modules are not intended to be moved, however **Fader** modules are interchangeable. The internal COM port connections determine the device addressing for each modules.

#### Pilot-6 Frame

- Houses 1x PLT-FADER & 1x PLT-MON
- 11.45" W x 15.4" D x 2.6" H (290mm x 391mm x 66mm)

#### Pilot-12 Frame

- Houses 2x PLT-FADER & 1x PLT-MON
- 18.95" W x 15.4" D x 2.6" H (481mm x 391mm x 66mm)

#### Pilot-18 Frame

- Houses 3x PLT-FADER & 1x PLT-MON
- 26.45" W x 15.4" D x 2.6" H (672mm x 391mm x 66mm)

## LED Meter (PLT-MTR)

A hardware LED **Meter** is available as an option. The **Meter** includes two high-resolution meters – one for Program bus and one switched (follows Monitor selection).

- 🔊 **TIP:** If the Pilot is powered on without being connected to the JetStream, all meter LEDs will illuminate. This is normal operation; the LEDs will turn off after being connected to the JetStream and the console begins to receive meter data.

### Mounting

- The **Meter** option is supplied separately and attaches to the back of the **Pilot** frame with two screws (included).
- The ribbon cable from the **Meter** attaches to an internal header via a small ribbon cable. The blue side of the ribbon cable should be up. Pass the ribbon cable through the frame and push the ribbon into the connector until it comes to a stop and gently close the brown latch on top of the ribbon cable. Take care to not use much force on this connector as it is very fragile.
- The **Meter** is not designed to be attached in another location.

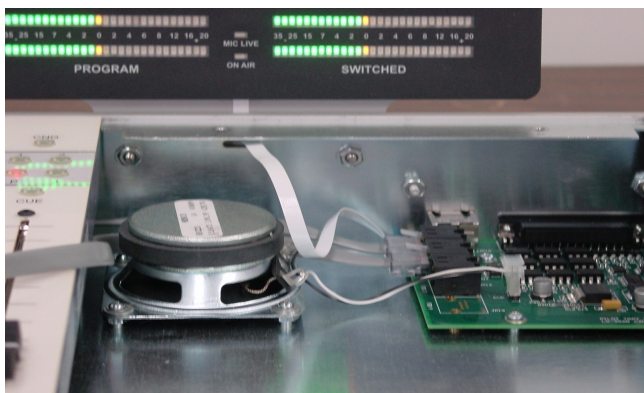

Figure 1: Pass the ribbon cable through the frame

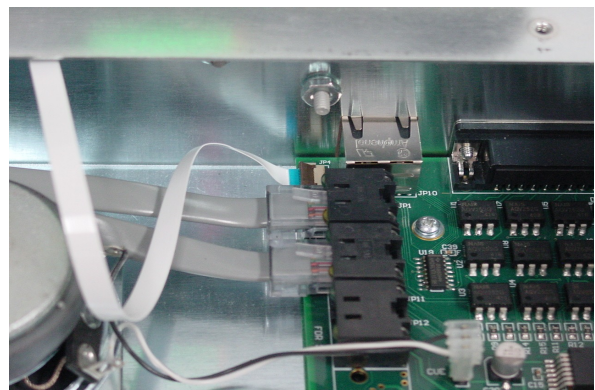

Figure 2: Gently snap the latch onto the cable.

### Dimensions

- 8.2" W x 2" H x 0.5" D (208.28 mm x 50.8 mm x 12.7 mm)
- The standard mounting adds 2.07" (52.5mm) to the height

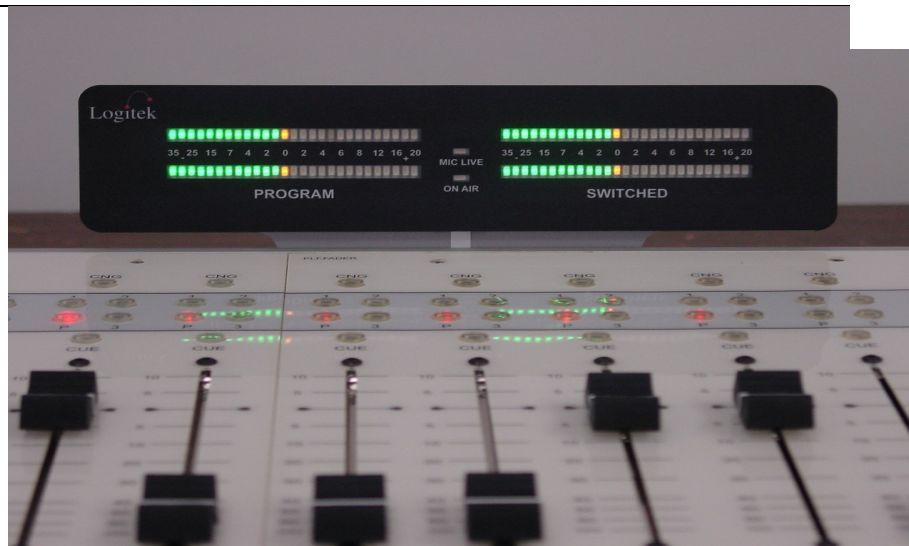
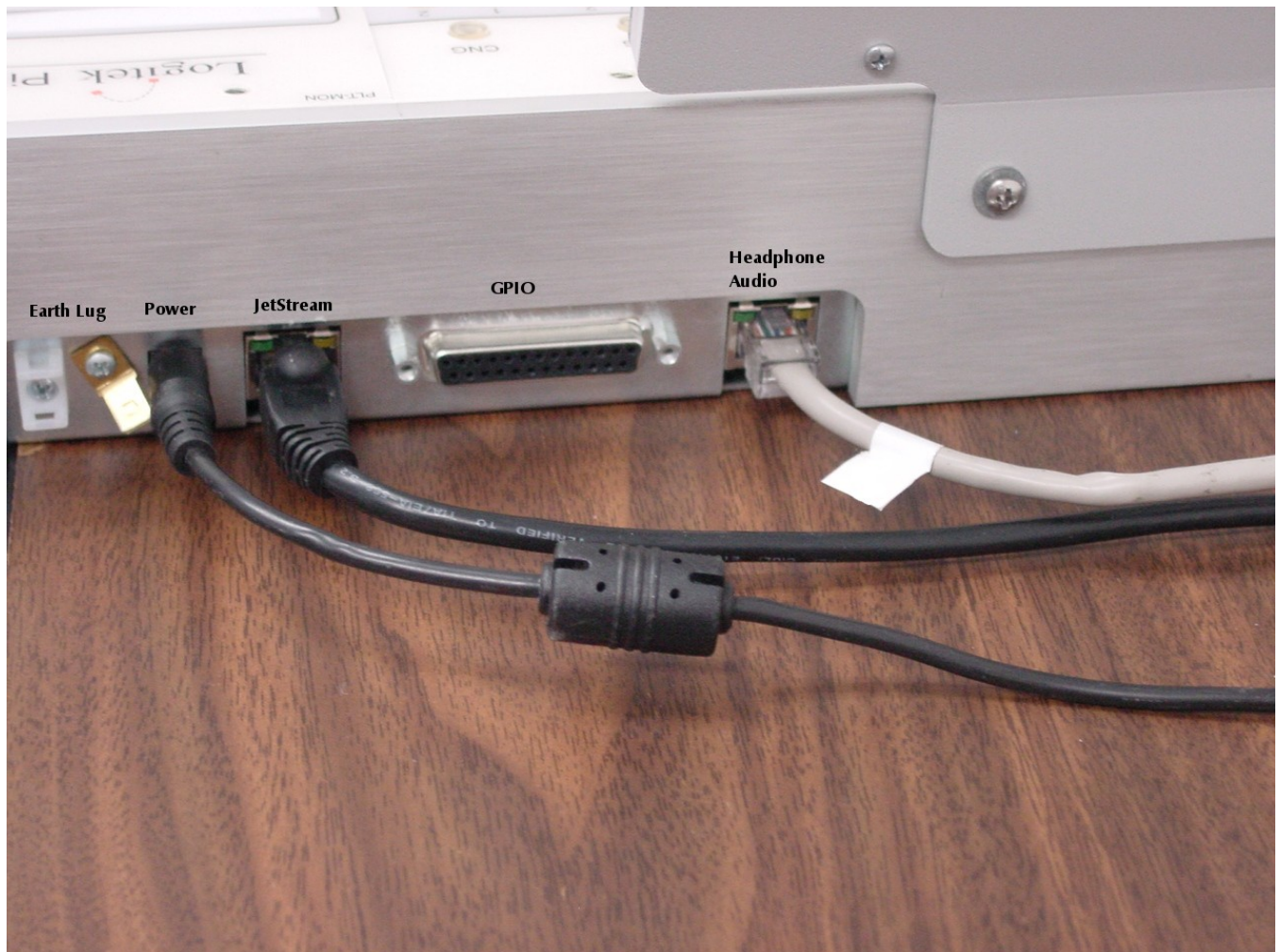

Figure 3: Pilot with Meter Bridge

## Connections

The *Pilot* frame contains the control and GPI circuitry for the console. It connects to the **Logitek JetStream Router** via a serial link. Headphone audio pass-through connectors are also provided for convenience.



**Figure 4 - Pilot Connection Diagram**

### PSU

The Pilot is powered by an external 12VDC 40W power supply, included with the console. Connect the supply to mains using an IEC style inlet lead and the 12VDC to the rear of the Pilot. The included supply can be replaced by any similar unit.

## Earth Lug

An earth lug is provided at the back of the frame for connection to station ground. The console also is grounded through the power cord.

## Frame to JetStream

The *Pilot Frame* connects to the **Logitek JetStream Router** using a balanced serial link. Connection from the *Pilot* to a **JetStream Router** JSM-DSP card is via a straight-through RJ45 cable (CAT5 or better is recommended).

You can use a dedicated CAT5 patch cable or existing structured cabling. If using structured cabling systems, care should be exercised to ensure the serial connections are not confused with other network outlets and that the link is not unintentionally “un-patched”.

## Headphones

The *Pilot* frame has a rear connection for Headphones input, which is internally wired to 1/4" (6.35mm) and 1/8" (3.5mm) headphone sockets at the front. This provides for convenient headphone connection without the need to mount an in-desk or under-desk socket.

Connection from the *Pilot* to **JetStream Router** is via a straight-through patch cable to a **JetStream** JSM-AOUT analog output card, which is suitable for driving headphones directly.

If you would prefer to provide a different audio connection, wiring is to the *StudioHUB+* standard.

↪ *See Appendix C for connector pinouts.*

## GPIs

The *Pilot Surface* has 6 GPI inputs and 9 GPI outputs for control of local studio devices.

GPI outputs are driven by optically-isolated, non-polarized, solid state switches, rated at 500ma to a maximum voltage of 24V AC/DC, with surge to 2A. These solid state devices do not conduct at low voltage, so cannot switch an audio input. However, they are suitable for most control signals, and avoid problems with relay contacts being damaged by surges. Caution should be exercised to avoid overloading the switches. If driving a high current device, we recommend using an external relay.

The GPI inputs are a current source to +3.3VDC that is pulled to ground to activate. This makes it suitable for control by push-button, relay or open collector. A diode protects against static and over voltage up to 18V. See the wiring diagram for polarity information if using non-standard activation methods. A common ground is provided for input connection.

GPI connections are on a single DB25 connector on the rear of the *Pilot* frame. As wiring schemes vary from station to station, these cables are not supplied with the surface, but are available from **Logitek Electronic Systems**. They can also be purchased from local suppliers in the required form.

→ See *Appendix C for connector pinouts*.

### Internal Module Connections

Inside the frame, four RJ45 port connectors are provided for connecting to each **Fader** module. These are provided as a straight-through flat cable, however any RJ45 patch will suffice.

The **Monitor** module connects to the internal PCB via the included flat rainbow ribbon cable. The connectors are keyed to ensure you cannot reverse the cable.

The **Meter** has a short flat cable that connects directly to the *Pilot* frame motherboard. This is plugged into the connector labeled JP4. The cable length is suitable to mount the **Meter** behind the *Pilot* frame. The **Meter** cannot be located elsewhere due to its cable requirement.

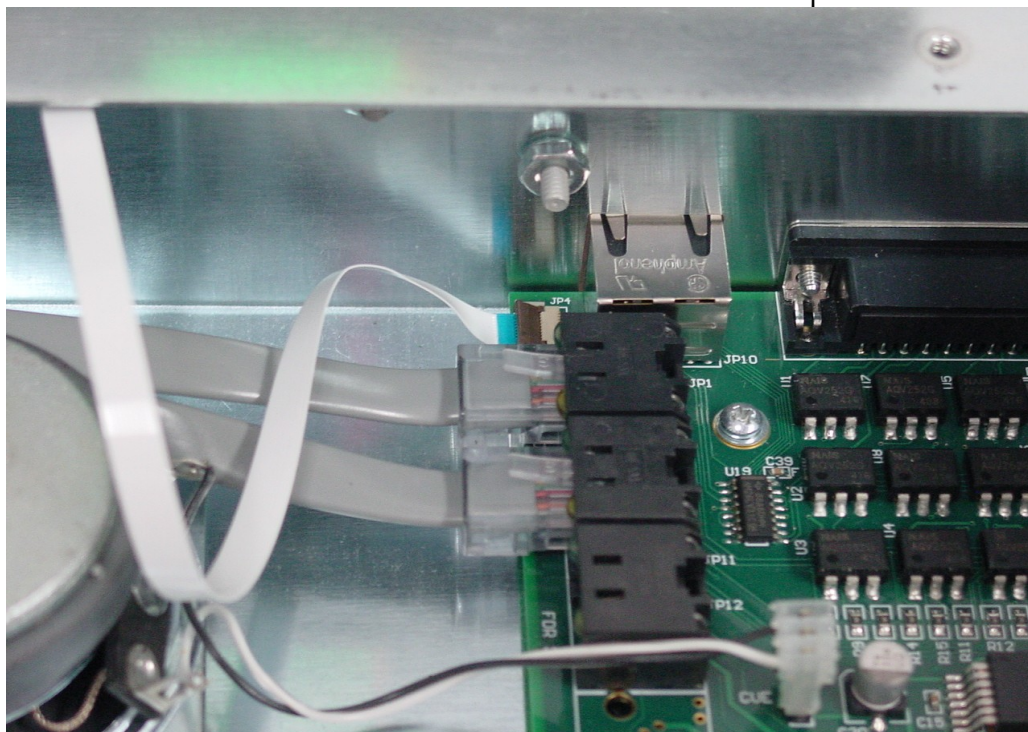

Figure 5: Internal Connections

## 4 Configuration

This chapter covers basic configuration information, relating specifically to the *Pilot* surface. **JetStream** setup and configuration is covered in detail in the following manuals:

- *Logitek JetStream Reference Manual*
- *Logitek AEConfig Reference Manual*

### JetStream Configuration

Configuration of the **JetStream Router** is done in *AEConfig*.

Currently, *AEConfig* does not include specific DSP table entries for the *Pilot*. You should use a Mosaic surface of the appropriate size when configuring a *Pilot*. In the future, specific *Pilot* support will be added to *AEConfig*, however, the two consoles are compatible in DSP allocations.

- ➔ *See the JetStream Reference Manual for information on configuring JetStreams.*

### CommandBuilder Triggers

The *Pilot* surface contains many programmable buttons and features. These features are scripted in “triggers” in *CommandBuilder*, and executed by *JetStream Server*, which is included with the JetNet Audio Networking Module.

- ➔ *See the CommandBuilder User’s Manual for information on writing Triggers.*

The *CommandBuilder* manual includes details and examples of *Pilot* specific features, such as Monitor Hotkeys, Bridge Buttons and more. The programming of these features does require a certain level of familiarity with the system. If you need assistance, please contact **Logitek Electronic Systems** or your reseller.



## Device & Bus Addressing

Each device (such as a fader input or button panel) requires its own **Device Number**. Within that device, each button, lamp and feature has a **Bus Number**. Together, the **Device** and **Bus Numbers** allow the **JetStream** and **Surface** to communicate.

When configuring the *Pilot's* programmable buttons in *CommandBuilder*, you will require the **Device Number** and **Bus Number** for each button or lamp. The information below will help you determine the addressing scheme in use on your *Pilot*.

### Modules

| Module    | How Addressing is determined  | Max Modules Supported |
|-----------|---|-----------------------|
| PLT-MON   | Uses the standard Monitor, Headphones, Guest/Studio & Cue Gain addressing | 1                     |
| PLT-FADER | Device Set determined by COM port allocation (pre-defined)                | 4 modules (24 faders) |
| PLT-METER | Uses standard PGM Meter addressing  | 1                     |

### Device Numbers

In *Pilot* v1.x the **Device Number** of a module is determined by its firmware and position.

### Dual Controls / Split Consoles

The *Pilot* does not support Dual Controls or Split Consoles. It is designed as a single self-contained console.

### Softkey Addressing

The twelve softkeys on the monitor module follow the **Numix** Bridge Button addressing scheme, therefore the `Bridge Button` and `Bridge Lamp` keywords in **Command Builder** may be used.

The softkey buttons for a console connected to JetStream port 1 are on device 28 and the lamps are on device 27. For port 2, use device 50 for buttons and 4F for lamps. For port 3, use device 64 for buttons and 63 for lamps. Bus numbers are 32-43.

For example, button #1 on a console connected to JetStream port 1 is device 28 bus 32 and its corresponding lamp is device 27 bus 32. Alternatively, it is valid to address button #1 on port 1 as `surf 1 bridgebutton 1` and its corresponding lamp as `surf 1 bridgelamp 1`. *Command Builder* will translate those keywords into the appropriate device and bus numbers.

**Port 1 – Button device 28/lamp device 27**

|        |    |    |    |    |    |    |    |    |    |    |    |    |
|--------|----|----|----|----|----|----|----|----|----|----|----|----|
| Button | 1  | 2  | 3  | 4  | 5  | 6  | 7  | 8  | 9  | 10 | 11 | 12 |
| Bus    | 32 | 33 | 34 | 35 | 36 | 37 | 38 | 39 | 40 | 41 | 42 | 43 |

**Port 2 – Button device 50/lamp device 4F**

|        |    |    |    |    |    |    |    |    |    |    |    |    |
|--------|----|----|----|----|----|----|----|----|----|----|----|----|
| Button | 1  | 2  | 3  | 4  | 5  | 6  | 7  | 8  | 9  | 10 | 11 | 12 |
| Bus    | 32 | 33 | 34 | 35 | 36 | 37 | 38 | 39 | 40 | 41 | 42 | 43 |

**Port 3 – Button device 64/lamp device 63**

|        |    |    |    |    |    |    |    |    |    |    |    |    |
|--------|----|----|----|----|----|----|----|----|----|----|----|----|
| Button | 1  | 2  | 3  | 4  | 5  | 6  | 7  | 8  | 9  | 10 | 11 | 12 |
| Bus    | 32 | 33 | 34 | 35 | 36 | 37 | 38 | 39 | 40 | 41 | 42 | 43 |

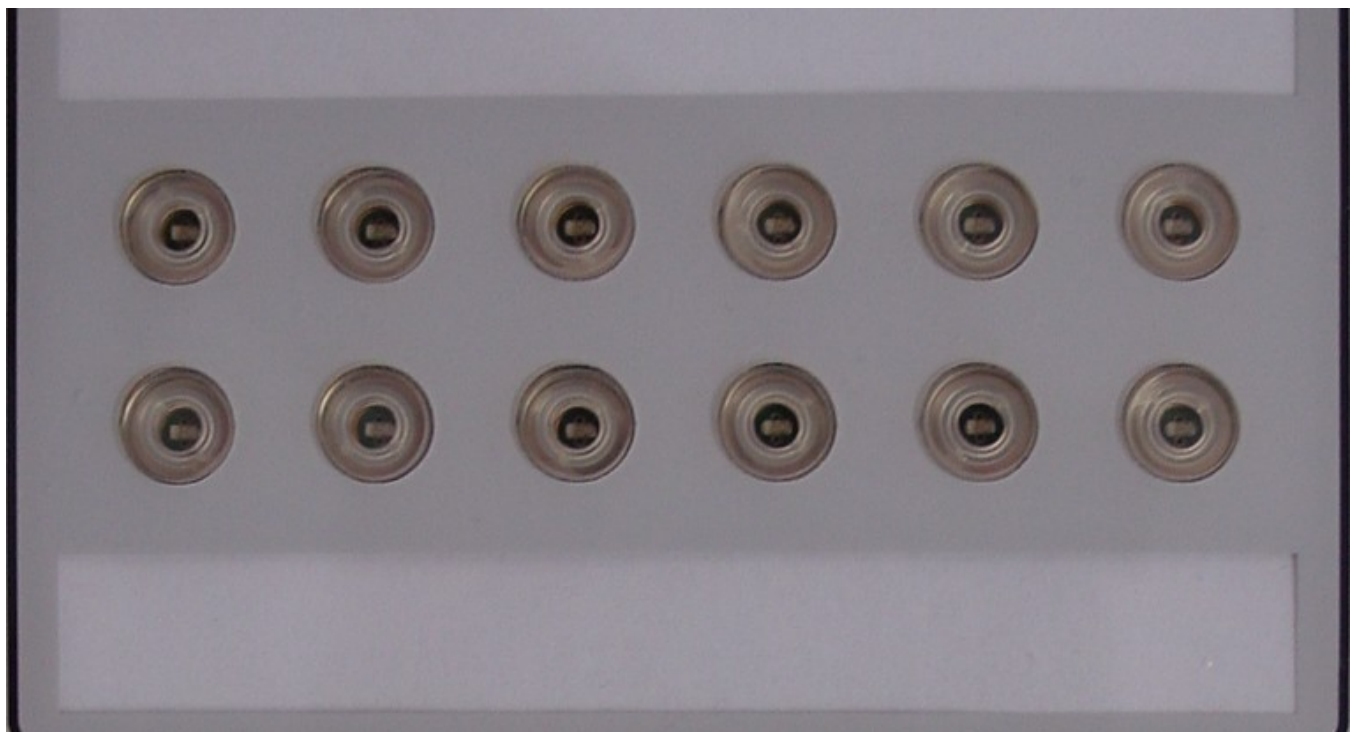

**Figure 6: Pilot softkey buttons**

The softkeys may be labeled by replacing the paper legend under the Lexan overlay. Beginning in April 2012, the cutout and paper legend has been removed. Space has been left on the module to affix labels.

## Monitor Hotkey Addressing

There are four monitor hotkeys that may be addressed in Command Builder to route sources to the control room monitors, headphones, and studio monitors.

Two of these hotkeys are labeled on the console: P (Program) and 1 (Aux 1). The other two may be labeled by replacing the paper legend under the Lexan overlay.

The device numbers are as follows:

| Port Number | Monitor   | Headphones | Studio    |
|-------------|-----------|------------|-----------|
| 1           | Device 24 | Device 25  | Device 23 |
| 2           | Device 4C | Device 4D  | Device 4B |
| 3           | Device 62 | Device 65  | Device 61 |

Alternatively, `d[device]` notation in Command Builder, such as `d[Port1 Monitor In]` is valid and will be properly translated by Command Builder.



Figure 7: Monitor Hotkey Bus Numbers

## Switched Meter Addressing (PLT-MTR only)

The Switched meter defaults to displaying whatever source is routed to Monitor In. When bus 0 is turned on for the Monitor Meter in device, the meter will switch to whatever source is routed to the Monitor Meter In.

Monitor Meter In Device Numbers:

| Port (Surface) Number | Device Number |
|-----------------------|---------------|
| 1                     | 2c            |
| 2                     | 54            |
| 3                     | 6a            |

In Command Builder, sources should be routed to `d[Port1 Monitor Meter In]` (or appropriate port number) using the Alt+D pick list. Command Builder will translate this into the appropriate hex device number.

## PLT-Meter On Air and Mic Live Tally Lamps

Two tally LEDs are provided on the PLT-METER. The Mic Live tally may be used to tell the operator that the mic is on. The On Air tally may be used to tell the operator that the console has been switched to air. The bus number of the Mic Live LED is 17 and the On Air LED is 18. The device numbers are in the chart below.

Device Numbers for Mic Live and On Air Tally Lamps

| Port (Surface) Number | Device Number |
|-----------------------|---------------|
| 1                     | 28            |
| 2                     | 4F            |
| 3                     | 63            |

Because these LEDs are on the same device number as console GPI outputs, an easy way to program the Mic Live lamp is to enter 117 into the Mute Tally box for each Mic on port 1. For port 2 consoles, use 217. For port 3 consoles, use 317.

## 5 Operation

Your **Logitek Pilot** console has been designed for easy and quick access to the functions you most need. If you've had experience with broadcast consoles before, you'll soon be at home, finding your way around quite easily.

**Logitek Electronic Systems** has been manufacturing broadcast consoles for decades, so we understand how to make control surfaces that are both powerful and straightforward. During the design of the *Pilot*, customers and operators provided feedback that helped shape the final product. So we're confident you'll find the *Pilot* a joy to use on-air.

Following is a look at each of the *Pilot* modules, and how the standard functions are used.



Figure 8 - Pilot 12

## Pilot Modules

### PLT-FADER (Fader Module) – International (non-UK) Layout

Change button. Press to route a new source to this fader. Use the select knob on the module to scroll through the sources on the OLED display below the fader. Press Take on the fader module to select the source; Cancel to clear change mode. Change mode will also automatically turn off after 5 seconds of inactivity.

P button – Program bus select. Press to send this channel to the program mixing bus. The lamp on the button will illuminate to show whether the bus is assigned or not. The lamp will glow at half brightness when the channel is off and full brightness when the channel is on.

1 button – Aux 1 bus select. Press to send this channel to the Aux 1 mixing bus. The lamp on the button will illuminate to show whether the bus is assigned or not. The lamp will glow at half brightness when the channel is off and full brightness when the channel is on.

2 button – Aux 2 bus select. Press to send this channel to the Aux 2 mixing bus. The lamp on the button will illuminate to show whether the bus is assigned or not. The lamp will glow at half brightness when the channel is off and full brightness when the channel is on.

3 button – Aux 3 bus select. Press to send this channel to the Aux 3 mixing bus. The lamp on the button will illuminate to show whether the bus is assigned or not. The lamp will glow at half brightness when the channel is off and full brightness when the channel is on.

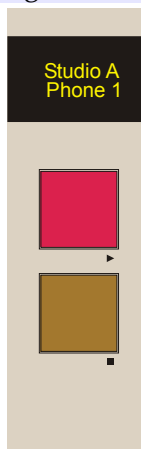

## PLT-MON (Monitor Module)

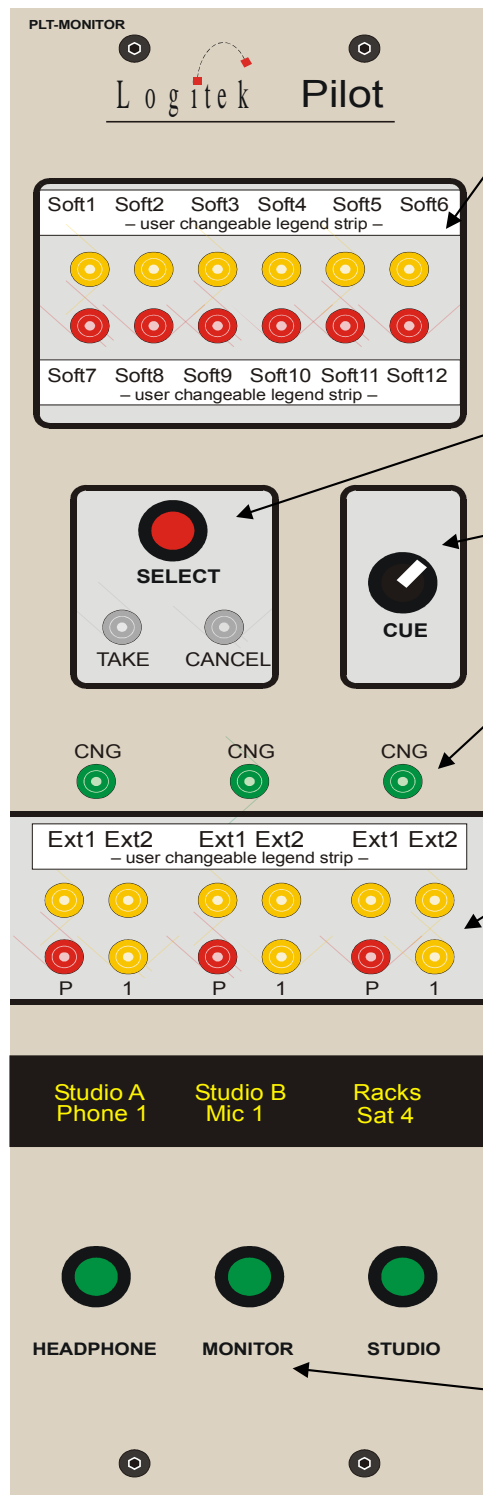

The bridge buttons are user-programmable and have label strips above or below. Common uses include intercoms, delay control and snapshot/record functions.

Use the **SELECT** wheel to change the input selection on the Fader or Monitoring source after pressing the **CNG** (Change) button. Winding the **SELECT** wheel will cycle through the available inputs, displaying on the relevant screen. Press **TAKE** to accept, or **CANCEL** to cancel the change.

Use the **CUE** knob to increase (clockwise) or decrease (anticlockwise) the level going to the *Pilot's* Cue speaker.

Use the **CNG** buttons to access the source change function for each of the monitoring destinations.

The monitor selection buttons include P (PGM), 1 (AX1) and two programmable buttons for "hotkey" sources. These allow direct access to commonly used sources.

The OLED screen displays the current source for each monitoring send. When the relevant CNG button is pressed, you can scroll through the selection list to select a new source.

Turn the **HEADPHONES**, **MONITOR** or **STUDIO** gain knobs to increase (clockwise) or decrease (anticlockwise) the level going to the relevant monitoring send.



## 6 Maintenance

The *Pilot* uses multi-layer boards with surface mount technology. As such, the majority of the console is not user-serviceable. However, there are some basic tasks that can be performed by suitably qualified technical personnel.

### Warranty

**Logitek Electronic Systems** will honor the warranty of the system when conducting field maintenance, provided:

- Repairs or updates only relate to recommended and documented procedures
- Care is taken and procedures are followed
- Repairs are conducted by suitably trained or experienced service personnel

If you do not feel comfortable performing maintenance or repairs, please do not proceed. If you would like advice prior to attempting a repair, please contact **Logitek Electronic Systems** or your reseller.

### Firmware Updates

Each module strip has internal memory that is field upgradeable. **Logitek Electronic Systems** or your value-added reseller may from time-to-time supply firmware updates to add new features or fix bugs.

### Component Replacement

The *Pilot* uses standard faders which can be replaced by station technicians.

#### Fader Replacement

The *Pilot* uses a Bourns carbon fader as its standard fader

**Model No**     **PTS01-11L-103B1**

Optionally, a *Pilot* may be equipped with Penny & Giles conductive plastic faders.

**Model No.**     **PGF3210/D/U/--A**

No audio is carried through the fader, just control signals. The fader can be easily replaced with a spare from Logitek or an electronics supplier.

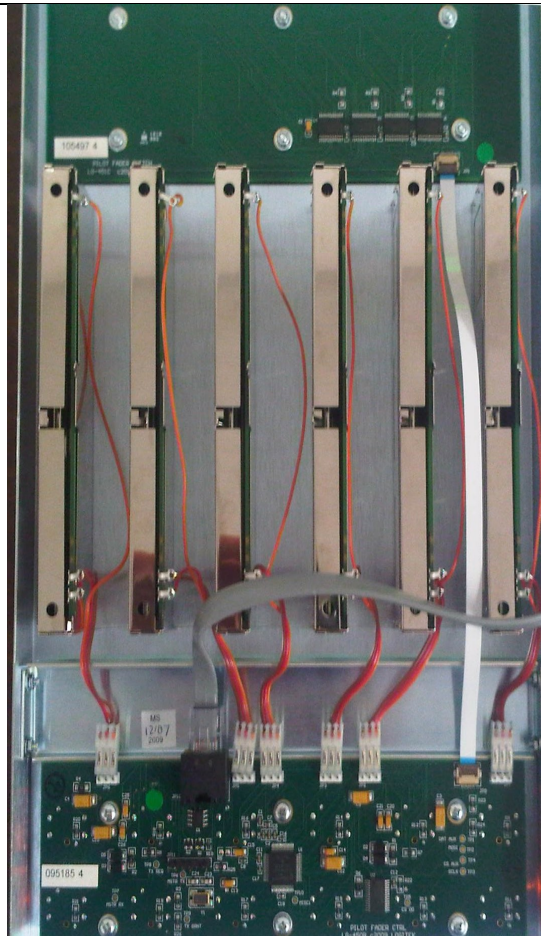

**Figure 9 - Faders from underside of module**

To replace a fader:

1. Remove the four screws from the required module.
2. Carefully remove the module from the frame.
3. Disconnect the fader from the main board.
4. Remove the slider cap.
5. Remove the two hex screws that mount the fader to the module.
6. Fit the replacement fader to the module using the two hex screws.
7. Replace the slider cap.
8. Reconnect the fader connector, ensuring the same polarity as the other faders on the module.
9. Replace the module in the frame, and screw it back in.

### **Module swap-out**

If you need to swap a module with an on-site spare, you can simply unscrew the module, disconnect it, connect the replacement and screw it in. Modules are fully hot-swappable – they will refresh their status shortly after powering up.

### **More Assistance**

If you would like more assistance with maintenance and service, please contact **Logitek** or your reseller.

## Appendix A Release Notes

### Known Issues

The following issues have been reported and are under investigation.

## Appendix B Specifications

### Pilot Frames

#### Pilot-6 Frame

- Houses 1x PLT-FADER & 1x PLT-MON
- 11.45" W x 15.4" D x 2.6" H (290mm x 391mm x 66mm)

#### Pilot-12 Frame

- Houses 2x PLT-FADER & 1x PLT-MON
- 18.95" W x 15.4" D x 2.6" H (481mm x 391mm x 66mm)

#### Pilot-18 Frame

- Houses 3x PLT-FADER & 1x PLT-MON
- 26.45" W x 15.4" D x 2.6" H (672mm x 391mm x 66mm)

#### Pilot-24 Frame

- Houses 4x PLT-FADER & 1x PLT-MON
- 33.95" W x 15.4" D x 2.6" H (862mm x 391mm x 66mm)

### Pilot Modules

#### Fader Module

**No of faders** 6

**Features**

The Fader Module provides the following features:

- LED-illuminated on/off and control start/stop buttons
- Bourns 100 mm long throw faders
- Dedicated controls for four bus assigns
- Yellow OLED display capable of displaying 16 character source names
- Available in standard (International) or U.K. configurations

#### Monitor Module

**Features**

The Monitor Module provides the following features:

- Contains controls for main monitor, cue speaker, operator headphone, studio monitor and guest headphone
- Studio, Monitor, and Operator Headphones each have 4 input select hotkey buttons

- 12 programmable softkeys
- Multifunction select knob for input selection, EQ, mode, pan and dynamics adjustment
- Yellow OLED screen displays 16-character source names
- Available in standard (International) or U.K. configurations

## Meter Bridge

### LED Meter Bridge

**Dimensions** 13" W x 3.8" H x 2.6" D (330 mm x 97 mm x 66 mm)

**Features** The Narrow Meter Bridge provides the following features:

- Two 27-LED stereo bar graph meters simultaneously showing peak and VU levels
- One meter always shows program, one meter is switchable
- LED indicator for studio and microphone tally

## Pilot Power Supply

**Voltage** 110 - 230 VAC, automatically selected

**Frequency** 47 - 63 Hz

**Consumption** 40 W maximum

## Appendix C Pinouts

### To JetStream

Connection to the **JetStream** is via a RJ45 connector mounted on the rear of the frame. Straight through CAT5 cabling is used.

| Pin | Connection |
|-----|------------|
| 1   | Cue -      |
| 2   | Cue +      |
| 3   | RS485 RX-  |
| 4   | RS485 TX-  |
| 5   | RS485 TX+  |
| 6   | RS485 RX+  |
| 7   | No connect |
| 8   | Ground     |

### GPIs

GPI connections are on a single DB25 connector at the rear of the frame. We recommend terminating GPIs to Krone style (or similar) termination blocks.

#### GPI Inputs & Outputs

| Pin | Connection | Pin | Connection |
|-----|------------|-----|------------|
| 1   | GPI Out 1a | 14  | GPI Out 1b |
| 2   | GPI Out 2a | 15  | GPI Out 2b |
| 3   | GPI Out 3a | 16  | GPI Out 3b |
| 4   | GPI Out 4a | 17  | GPI Out 4b |
| 5   | GPI Out 5a | 18  | GPI Out 5b |
| 6   | GPI Out 6a | 19  | GPI Out 6b |
| 7   | GPI Out 7a | 20  | GPI Out 7b |
| 8   | GPI Out 8a | 21  | GPI Out 8b |
| 9   | GPI Out 9a | 22  | GPI Out 9b |
| 10  | GPI In 1   | 23  | GPI In 2   |
| 11  | GPI In 3   | 24  | GPI In 4   |
| 12  | GPI In 5   | 25  | GPI In 6   |
| 13  | Ground     |     |            |





## Two Year Limited Warranty

Logitek Electronic Systems, Inc. warrants its professional equipment (excluding Logitek Software, which is covered by a separate warranty) against defects in materials and workmanship for two years pursuant to the following terms and conditions. The warranty extends to the original purchaser only.

LOGITEK will repair or replace, at its option, at its factory without charge professional equipment if a defect in materials or workmanship develops during the first two years following purchase, when the equipment is returned to the factory or LOGITEK authorized service centers freight prepaid with a description of the nature of the failure. No reimbursements can be made for repair charges that are not factory authorized. After repair or replacement, LOGITEK will return the equipment to the purchaser freight prepaid.

In the event that any part of this professional equipment becomes defective during the first two years following purchase, and purchaser wishes to attempt repair, purchaser may obtain a replacement part by notifying LOGITEK of the part of the equipment which has failed. LOGITEK will thereafter ship a replacement part, freight prepaid. LOGITEK may require the purchaser to return the defective part to LOGITEK freight prepaid as a condition of such replacement, either before or after LOGITEK ships the replacement part. LOGITEK shall not be responsible for any other charges or liabilities associated with purchaser-made repairs.

No part or equipment shall be considered defective if it fails to operate due to exposure to extreme temperatures or excessive moisture in the atmosphere.

Light bulbs, batteries, potentiometers or other equipment not manufactured by Seller shall carry only the warranty, if any, of the original equipment manufacturer in effect at the time of shipment of this order; and Seller's obligation under this warranty shall be limited to such adjustment as Seller may obtain from the original manufacturer.

This limited warranty is void if equipment is modified or repaired without authorization; subjected to misuse, abuse, accident, water damage or other neglect; or has had its serial number defaced or removed. No obligation is assumed by LOGITEK to update previously manufactured equipment. Specifications are subject to change without notice. **EXCEPT AS SPECIFICALLY PROVIDED HEREIN, LOGITEK MAKES NO WARRANTY, REPRESENTATION, PROMISE, OR GUARANTEE, EITHER EXPRESS OR IMPLIED, STATUTORY OR OTHERWISE, WITH RESPECT TO THE EQUIPMENT, USER DOCUMENTATION OR RELATED TECHNICAL SUPPORT, INCLUDING THEIR QUALITY, PERFORMANCE, MERCHANTABILITY OR FITNESS FOR A PARTICULAR PURPOSE. IN NO EVENT WILL LOGITEK BE LIABLE FOR INDIRECT, SPECIAL, INCIDENTAL, TORT, ECONOMIC, COVER, OR CONSEQUENTIAL DAMAGES ARISING OUT OF THE USE OF OR INABILITY TO USE LOGITEK PRODUCTS, EQUIPMENT, OR SERVICES, INCLUDING, WITHOUT LIMITATION, DAMAGES OR COSTS RELATING TO THE LOSS OF PROFITS, BUSINESS, GOODWILL, DATA OR COMPUTER PROGRAMS, EVEN IF ADVISED OF THE POSSIBILITY OF SUCH DAMAGES. IN NO CASE SHALL LOGITEK 'S LIABILITY FOR MONEY DAMAGES EXCEED THE AMOUNT PAID BY YOU FOR THE LOGITEK EQUIPMENT OUT OF WHICH SUCH CLAIM AROSE. THE FOREGOING LIMITATIONS SHALL NOT APPLY TO CLAIMS RELATING TO DEATH OR PERSONAL INJURY WHICH ARISE OUT OF PRODUCTS DEEMED TO BE CONSUMER GOODS UNDER APPLICABLE LAW.**

Some states or provinces do not allow the exclusion or limitation of implied warranties or limitation of liability for incidental or consequential damages, so the above exclusion or limitation may not apply to you.

The warranty and remedies set forth herein are exclusive and in lieu of all others, oral or written, express or implied. No Logitek dealer, distributor, agent, or employee is authorized to make any modification or addition to this warranty.