

SHEERSASH 34
WINDOW SYSTEM

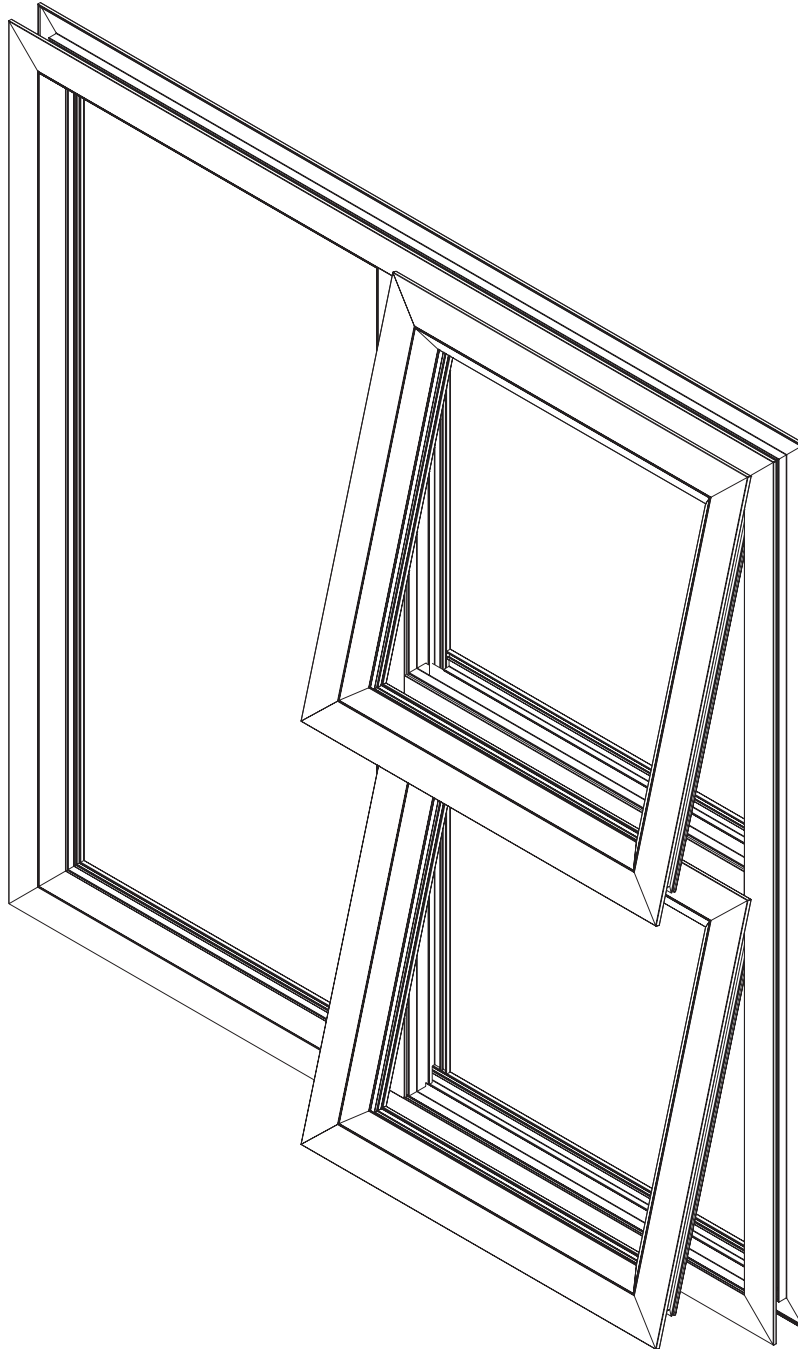

PRODUCT MANUAL

Disclaimer: The right to make alterations is reserved
© 2010 Sheerline, All Rights Reserved

Revision: 01/10/2010



LEGAL DISCLAIMER

All information, recommendations or advice contained in this documentation is given in good faith to the best of Sheerline's knowledge and is based on current procedures in effect.

Since the actual use of this documentation by the user is beyond the control of Sheerline, such use is within the exclusive responsibility of the user. Sheerline cannot be held responsible for any loss incurred through incorrect or faulty use of this documentation.

Great care has been taken to ensure that the information provided is correct. Sheerline will accept no responsibility for any errors and/or omissions, which may have inadvertently occurred.

All mechanical joints must be sealed with a Sheerline approved joint sealer.

Laminated glass must not stand in water.

All drawings in the Sheerline Documentation are shown NOT to scale.

Sheerline cannot accept responsibility for the use of standard products since Sheerline does not know where these products are being installed.

The use of anti-magnetic stainless steel screws and pop rivets is recommended to reduce galvanic corrosion in harsh environments.

The hardware recommended in this documentation is suitable for use in most atmospheric environments. When hardware is used in severe coastal environments the manufacturer of the hardware must be consulted.

Fixing lugs on frames must be positioned as per the user manual and used in accordance to the AAAMSA specifications. When profiles are screwed together the screw centers must also be according to the user manual.

All glass used within Sheerline products must comply with SAGGA regulations.

By continuing to use this documentation you acknowledge that you understand and accept the legal disclaimer.

SHEERSASH 34 WINDOW SYSTEM PROFILE IDENTIFICATION

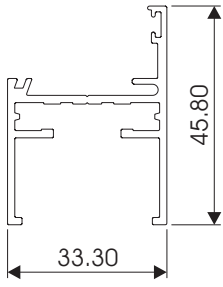

CAS340 EQUAL LEG
OUTER FRAME
3404

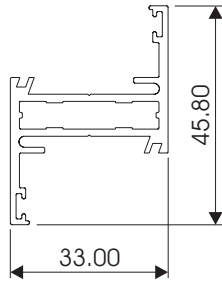

CAS340 TUBULAR SASH
3401

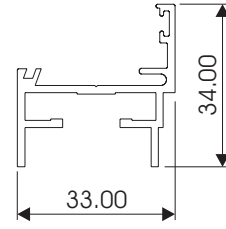

CAS340 SHORT LEG
OUTER FRAME
3410

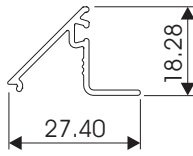

NEW CAS340 GLAZING
BEAD
3414

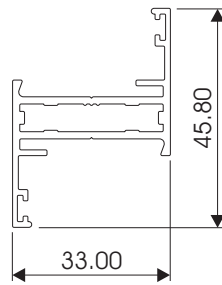

NEW CAS340 TUBULAR SASH
3416A

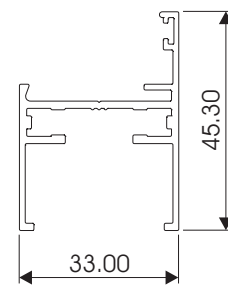

NEW CAS340 EQUAL LEG
OUTER FRAME
3415A

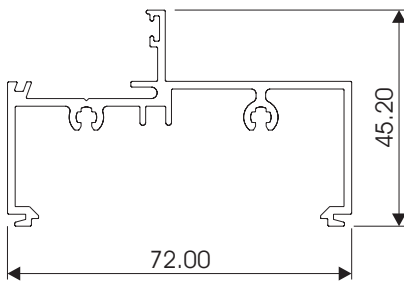

750 SIDELIGHT FRAME 72mm
3418

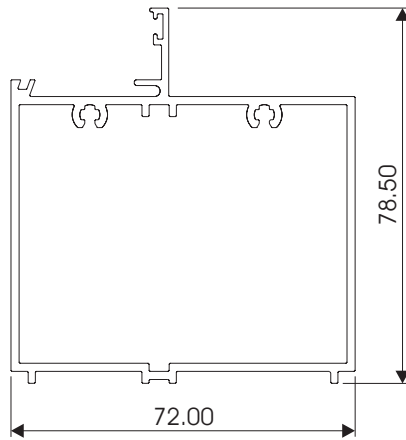

750 SIDELIGHT BOX SILL 72mm
W10562

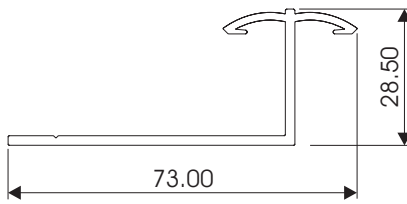

CAS340 FIXING LUG
3407

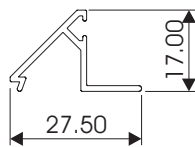

CAS340 GLAZING
BEAD
3403

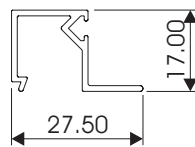

CAS340 SQUARE
BEAD
3412

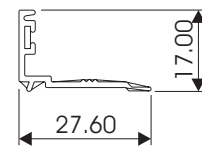

CAS340 DOUBLE
GLAZING BEAD
3413

SHEERSASH 34 WINDOW SYSTEM PROFILE IDENTIFICATION

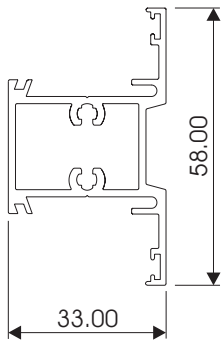

CAS340 STANDARD
MULLION
W10197

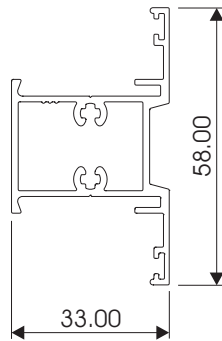

CAS340 MULLION
W55692

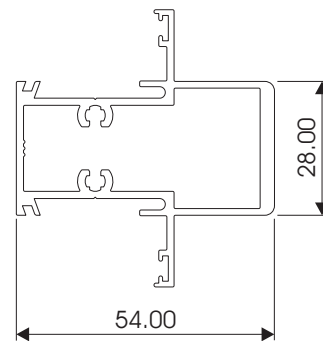

CAS340 54mm
MULLION
W55193

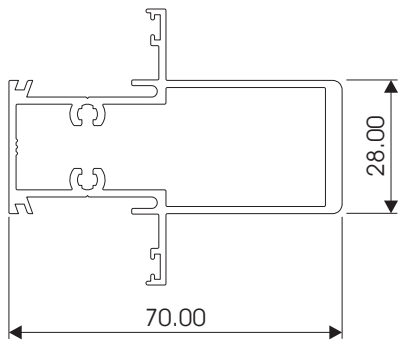

CAS340 70mm
MULLION
3408

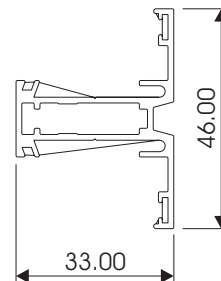

CAS340 COTTAGE
PANE MULLION
3409A

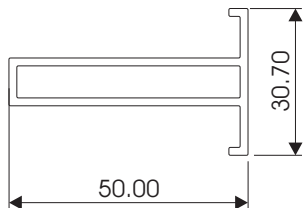

SMALL T COUPLING MULLION
W11019

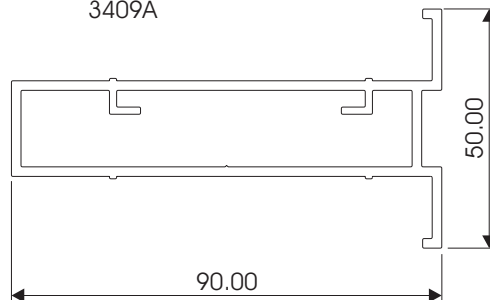

BIG T COUPLING MULLION
W10593

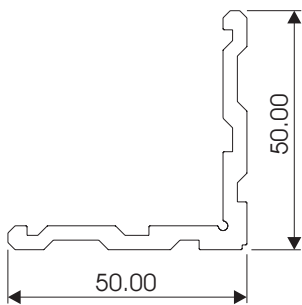

CAS340 CORNER
CLEAT
3405

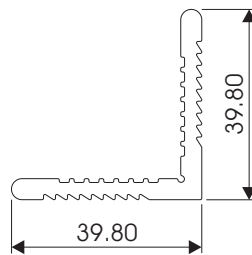

OSBORNE MULTI
CORNER CLEAT
W52538

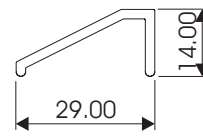

CAS340 ADD ON
WEATHER BAR
3411

SHEERSASH 34 WINDOW SYSTEM HARDWARE IDENTIFICATION

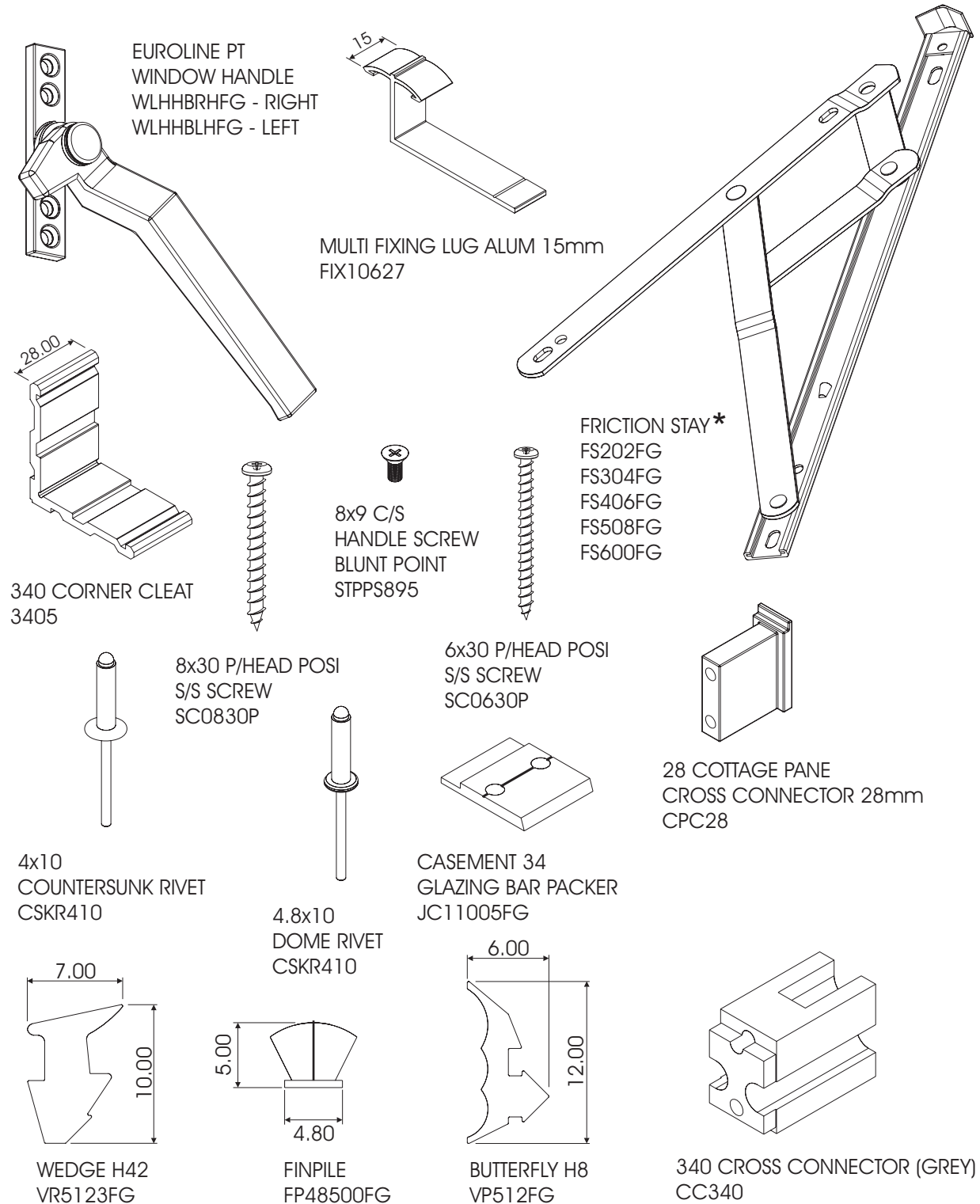

*** MAINTENANCE OF STAINLESS STEEL FRICTION STAYS**

To preserve the appearance and prevent corrosion, wipe down Friction Stays with warm water and a mild detergent. For stubborn dirt or stains, use a non corrosive cleaner, for more aggressive stains add a small amount of vinegar to water. Carbon steel brushes and steel wool should be avoided as they may leave particles embedded in the surface which may lead to rusting. After cleaning rinse with hot water and dry using a clean cloth. Cleaning is recommended once a month or more frequently when subjected to regular use or heavy soiling.

SHEERSASH 34 WINDOW SYSTEM

SASH LIMITATION CHARTS



		Maximum Vent Width in mm	Maximum Vent Height in mm
Top Hung	3401	1200	900

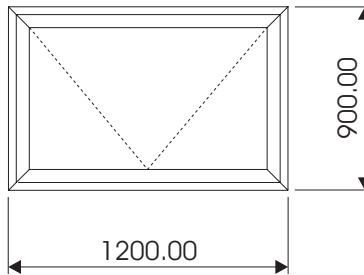

		Maximum Vent Width in mm	Maximum Vent Height in mm
Side Hung	3401	700	1500

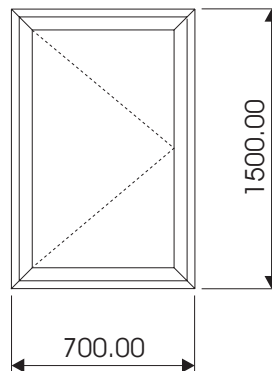

STANDARD TOP HUNG SHEERSASH 34 WINDOWS 600Pa WINDLOAD



NOTE:

1. SEE THE MULLION LIMITATION CHART
2. OPENING SIZES SHOWN IN RED
3. ACTUAL WINDOW SIZES SHOWN IN BLACK AND BRACKETS.

	600 (590)	900 (890)	1 200 (1190)	1 500 (1490)	1 800 (1790)	2 400 (2390)
600 (590)	 340-0606T	 340-0906T	 340-1206T	 340-1506T	 340-1806TT	 340-2406TT
900 (890)	 340-0609T	 340-0909T	 340-1209T	 340-1509T	 340-1809TT	 340-2409TT
1200 (1190)	 340-0612T	 340-0912T	 340-1212DT	 340-1512DT	 340-1812DT	 340-2412DT
1500 (1490)	 340-0615DT	 340-0915DT	 340-1215DT	 340-1515DT 66mm Mull W1 0252	 340-1815DT 66mm Mull W1 0252	 340-2415DT 66mm Mull W1 0252
1800 (1790)	 340-0618DT	 340-0918DT	 340-1218DT 66mm Mull W1 0252	 340-1518DT 66mm Mull W1 0252	 340-1818DT 66mm Mull W1 0252	 340-2418DT 66mm Mull W1 0252

STANDARD TOP HUNG SHEERSASH 34 WINDOWS 1000Pa WINDLOAD



NOTE:









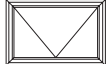
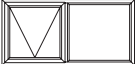
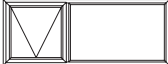

1. SEE THE MULLION LIMITATION CHART
2. OPENING SIZES SHOWN IN RED
3. ACTUAL WINDOW SIZES SHOWN IN BLACK AND BRACKETS.

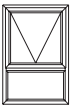
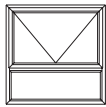
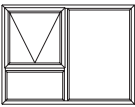
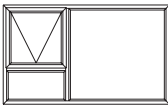
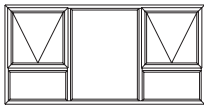
	600 (590)	900 (890)	1 200 (1190)	1 500 (1490)	1 800 (1790)	2 400 (2390)
600 (590)	 340-0606T	 340-0906T	 340-1206T	 340-1506T	 340-1806TT	 340-2406TT
900 (890)	 340-0609T	 340-0909T	 340-1209T	 340-1509T	 340-1809TT	 340-2409TT
1200 (1190)	 340-0612T	 340-0912T	 340-1212DT	 340-1512DT	 340-1812DT	 340-2412DT
1500 (1490)	 340-0615DT	 340-0915DT	 340-1215DT 66mm Mullion W1 0252	 340-1515DT 66mm Mullion W1 0252	 340-1815DT 66mm Mullion W1 0252	 340-2415DT 66mm Mullion W1 0252
1800 (1790)	 340-0618DT	 340-0918DT	 340-1218DT 66mm Mullion W1 0252	 340-1518DT 66mm Mullion W1 0252	 340-1818DT 66mm Mullion W1 0252	 340-2418DT 66mm Mullion W1 0252

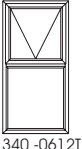
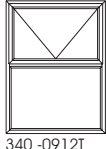
STANDARD TOP HUNG SHEERSASH 34 WINDOWS 1500Pa WINDLOAD

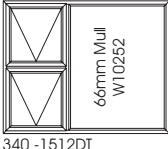
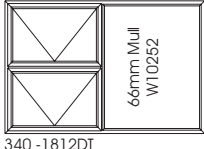
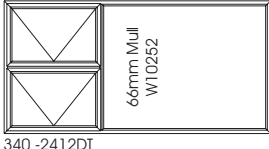
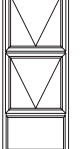
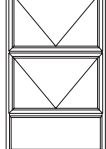
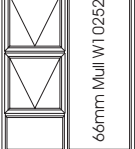
NOTE:

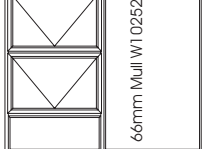
1. SEE THE MULLION LIMITATION CHART
2. OPENING SIZES SHOWN IN RED
3. ACTUAL WINDOW SIZES SHOWN IN BLACK AND BRACKETS.

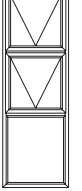
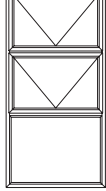
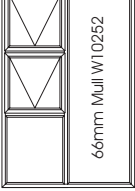
	600 (590)	900 (890)	1 200 (1190)	1 500 (1490)	1 800 (1790)	2 400 (2390)
600 (590)	 340-0606T	 340-0906T	 340-1206T	 340-1506T	 340-1806TT	 340-2406TT
900 (890)	 340-0609T	 340-0909T	 340-1209T	 340-1509T	 340-1809TT	 340-2409TT
1200 (1190)	 340-0612T	 340-0912T	 340-1212DT 66mm Mull W10252	 340-1512DT 66mm Mull W10252	 340-1812DT 66mm Mull W10252	 340-2412DT 66mm Mull W10252
1500 (1490)	 340-0615DT	 340-0915DT	 340-1215DT 66mm Mull W10252	 340-1515DT 66mm Mull W10252	 340-1815DT 66mm Mull W10252	 340-2415DT 66mm Mull W10252
1800 (1790)	 340-0618DT	 340-0918DT	 340-1218DT 66mm Mull W10252			

STANDARD SIDE HUNG SHEERSASH 34 WINDOWS 600Pa WINDLOAD



NOTE:

1. SEE THE MULLION LIMITATION CHART
2. OPENING SIZES SHOWN IN RED
3. ACTUAL WINDOW SIZES SHOWN IN BLACK AND BRACKETS.

	600 (590)	900 (890)	1 200 (1190)	1 500 (1490)	1 800 (1790)	2 400 (2390)
600 (590)						
900 (890)	 340-0609S	 340-0909S	 340-1209S	 340-1509S	 340-1809SS	 340-2409SS
1200 (1190)	 340-0612S	 340-0912S	 340-1212S	 340-1512S	 340-1812SS	 340-2412SS
1500 (1490)	 340-0615S	 340-0915S	 340-1215S	 340-1515S 66mm Mull W1 0252	 340-1815SS	 340-2415SS 66mm Mull W1 0252
1800 (1790)	 340-0618S	 340-0918S 66mm Mull W1 0252	 340-1218S 66mm Mull W1 0252	 340-1518S 66mm Mull W1 0252	 340-1818SS 66mm Mull W1 0252	 340-2418SS 66mm Mull W1 0252

STANDARD SIDE HUNG SHEERSASH 34 WINDOWS 1000Pa WINDLOAD



NOTE:

1. SEE THE MULLION LIMITATION CHART
2. OPENING SIZES SHOWN IN RED
3. ACTUAL WINDOW SIZES SHOWN IN BLACK AND BRACKETS.

	600 (590)	900 (890)	1 200 (1190)	1 500 (1490)	1 800 (1790)	2 400 (2390)
600 (590)						
900 (890)	 340 -0609S	 340 -0909S	 340 -1209S	 340 -1509S	 340 -1809SS	 340 -2409SS
1200 (1190)	 340 -0612S	 340 -0912S	 340 -1212S	 340 -1512S	 340 -1812SS	 340 -2412SS
1500 (1490)	 340 -0615S	 340 -0915S 66mm Mull W1 0252	 340 -1215S 66mm Mull W1 0252	 340 -1515S 66mm Mull W1 0252	 340 -1815SS 66mm Mull W1 0252	 340 -2415SS 66mm Mull W1 0252
1800 (1790)	 340 -0618S	 340 -0918S 66mm Mull W1 0252	 340 -1218S 66mm Mull W1 0252	 340 -1518S 66mm Mull W1 0252	 340 -1818SS 66mm Mull W1 0252	 340 -2418SS 66mm Mull W1 0252

STANDARD SIDE HUNG SHEERSASH 34 WINDOWS 1500Pa WINDLOAD

NOTE:

1. SEE THE MULLION LIMITATION CHART
2. OPENING SIZES SHOWN IN RED
3. ACTUAL WINDOW SIZES SHOWN IN BLACK AND BRACKETS.

	600 (590)	900 (890)	1 200 (1190)	1 500 (1490)	1 800 (1790)	2 400 (2390)
600 (590)						
900 (890)	 340-0609S	 340-0909S	 340-1209S	 340-1509S	 340-1809SS	 340-2409SS
1200 (1190)	 340-0612S	 340-0912S	 340-1212S 66mm Mull W10252	 340-1512S 66mm Mull W10252	 340-1812SS 66mm Mull W10252	 340-2412SS 66mm Mull W10252
1500 (1490)	 340-0615S	 340-0915S 66mm Mull W10252	 340-1215S 66mm Mull W10252	 340-1515S 66mm Mull W10252	 340-1815SS 66mm Mull W10252	 340-2415SS 66mm Mull W10252
1800 (1790)	 340-0618S	 340-0918S 66mm Mull W10252	 340-1218S 66mm Mull W10252	 340-1818SS 66mm Mull W10252		

SHEERSASH 34 SYSTEM
STANDARD TOP HUNG WINDOW
TYPICAL CONFIGURATIONS

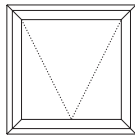

A
SINGLE TOP HUNG

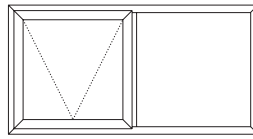

BB
TOP HUNG
NEXT TO FIXED

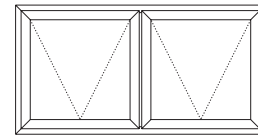

CC
TOP HUNG NEXT
TO TOP HUNG

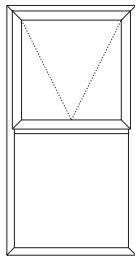

B
TOP HUNG
OVER FIXED

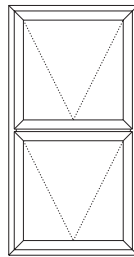

C
TOP HUNG
OVER TOP HUNG

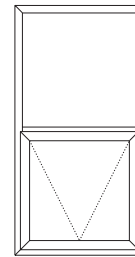

E
FIXED OVER
TOP HUNG

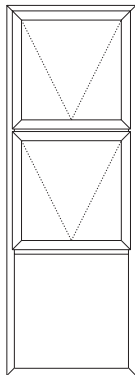

D
DOUBLE TOP HUNG
OVER FIXED

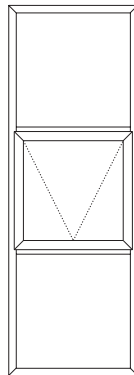

DD
FIXED OVER
TOP HUNG
OVER FIXED

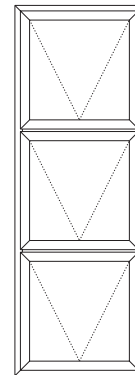

EE
TRIPLE TOP HUNG

SHEERSASH 34 SYSTEM
STANDARD SIDE HUNG WINDOW
TYPICAL CONFIGURATIONS

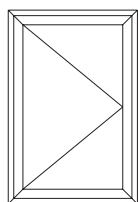

A
SINGLE SIDE HUNG

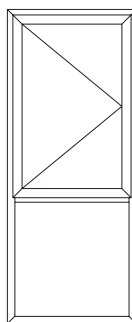

B
SIDE HUNG
OVER FIXED

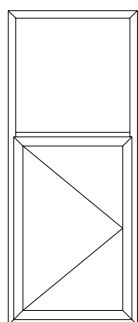

C
FIXED OVER
SIDE HUNG

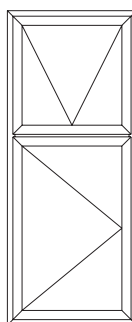

D
TOP HUNG
OVER SIDE HUNG

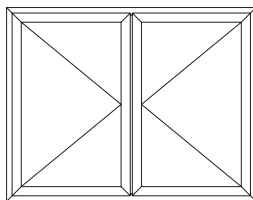

CC
SIDE HUNG NEXT
TO SIDE HUNG

SHEERSASH 34 SYSTEM
COTTAGE PANE WINDOW FIXED
PANEL TYPICAL CONFIGURATIONS

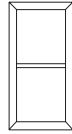

A
1 x 2 FIXED PANEL

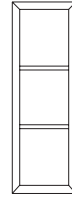

B
1 x 3 FIXED PANEL

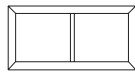

C
2 x 1 FIXED PANEL

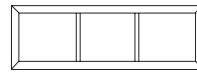

D
3 x 1 FIXED PANEL

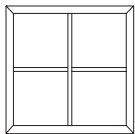

E
2 x 2 FIXED PANEL

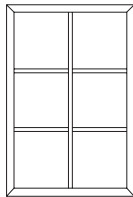

F
2 x 3 FIXED PANEL

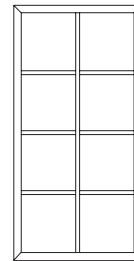

G
2 x 4 FIXED PANEL

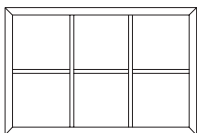

H
3 x 2 FIXED PANEL

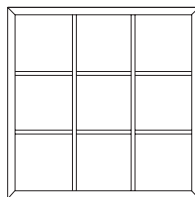

I
3 x 3 FIXED PANEL

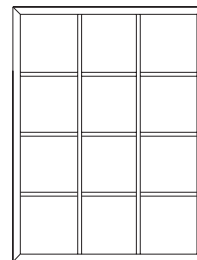

J
3 x 4 FIXED PANEL

SHEERSASH 34 SYSTEM
COTTAGE PANE WINDOW
TOP HUNG & SIDE HUNG
TYPICAL CONFIGURATIONS

TOP HUNG

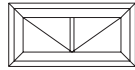

P

2 x 1 PANE
SINGLE TOP HUNG

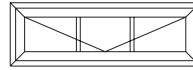

R

3 x 1 PANE
SINGLE TOP HUNG

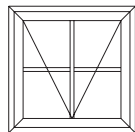

Q

2 x 2 PANE
SINGLE TOP HUNG

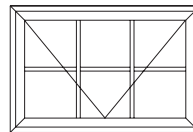

S

3 x 2 PANE
SINGLE TOP HUNG

SIDE HUNG

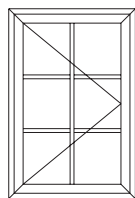

P

2 x 3 PANE
SINGLE SIDE HUNG

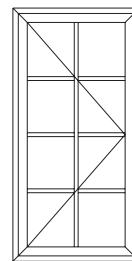

Q

2 x 4 PANE
SINGLE SIDE HUNG

SHEERSASH 34 WINDOW SYSTEM FASTENING POSITIONS

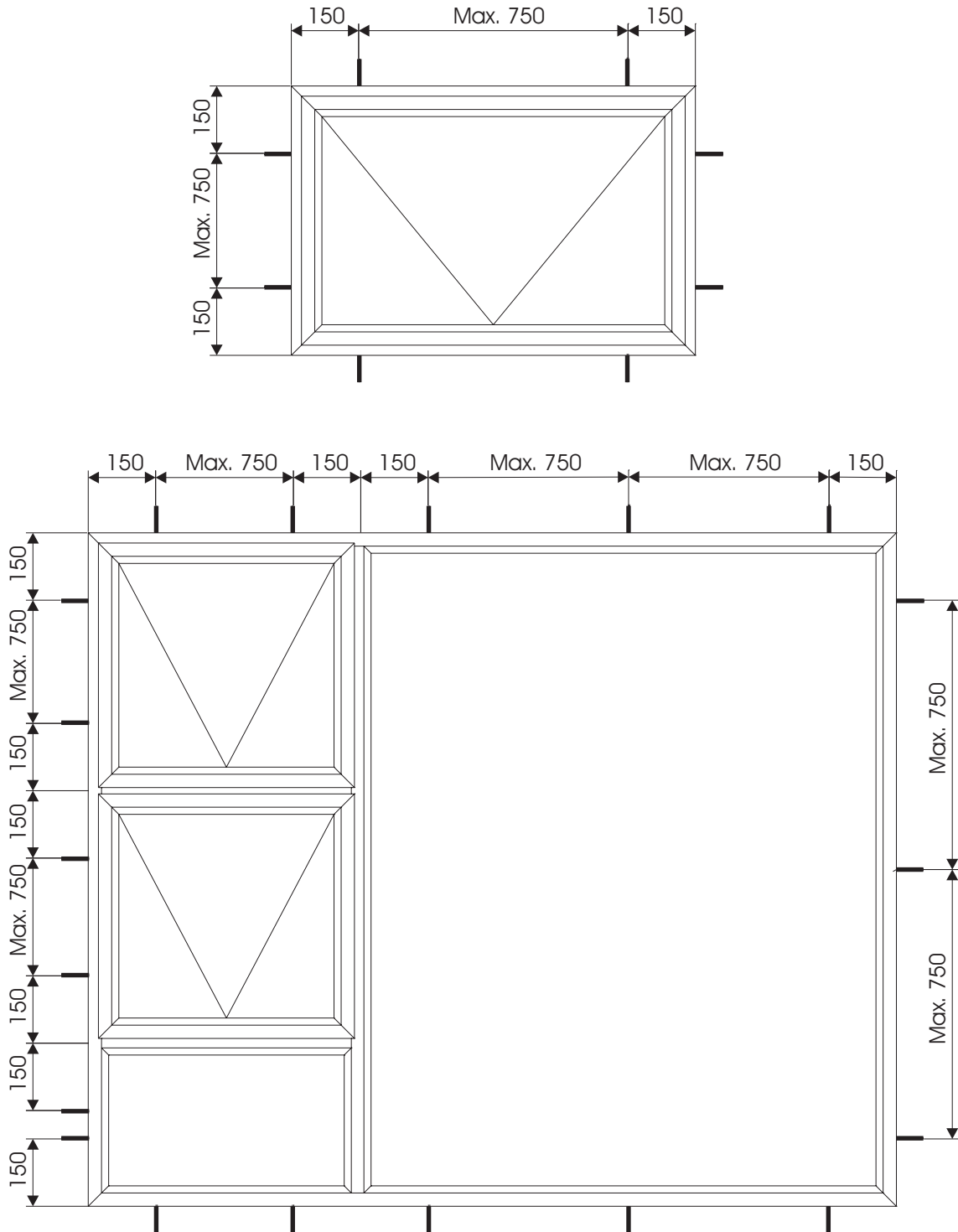

General:

The window is fixed into position - the sill is then built at a later stage - the bottom lugs can be left in place but it is often found that most times the mason either bends them out of his way or breaks them off. This practically means that most windows are only secured on 3 sides.

Disclaimer: The right to make alterations is reserved

© 2010 Sheerline, All Rights Reserved

SHEERSASH 34 WINDOW SYSTEM TYPICAL COUPLING CONFIGURATIONS

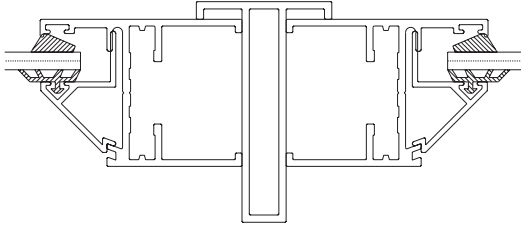

MULLION COUPLING DETAIL
EQUAL LEG OUTER FRAME &
SMALL T COUPLING MULLION
(3401 + W11019)

MAXIMUM HEIGHT: 1500mm

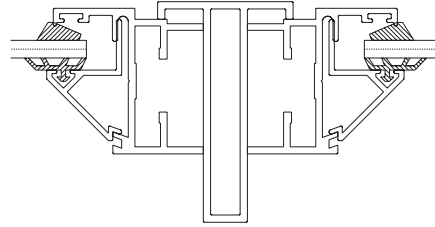

MULLION COUPLING DETAIL
SHORT LEG OUTER FRAME &
SMALL T COUPLING MULLION
(3410 + W11019)

MAXIMUM HEIGHT: 1500mm

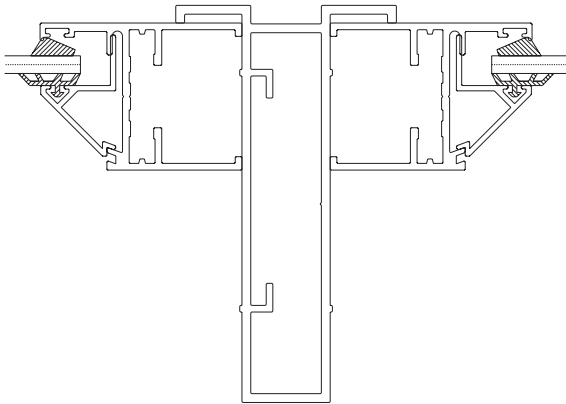

MULLION COUPLING DETAIL
EQUAL LEG OUTER FRAME &
BIG T COUPLING MULLION
3404 + W10593)

MAXIMUM HEIGHT: 1500mm

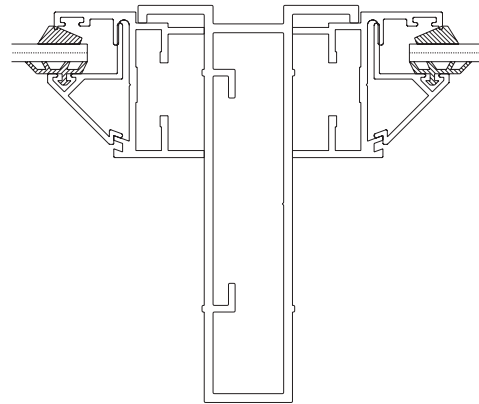

MULLION COUPLING DETAIL
SHORT LEG OUTER FRAME &
BIG T COUPLING MULLION
(3410 + W10593)

MAXIMUM HEIGHT: 1500mm

SHEERSASH 34 WINDOW SYSTEM FASTENING POSITIONS

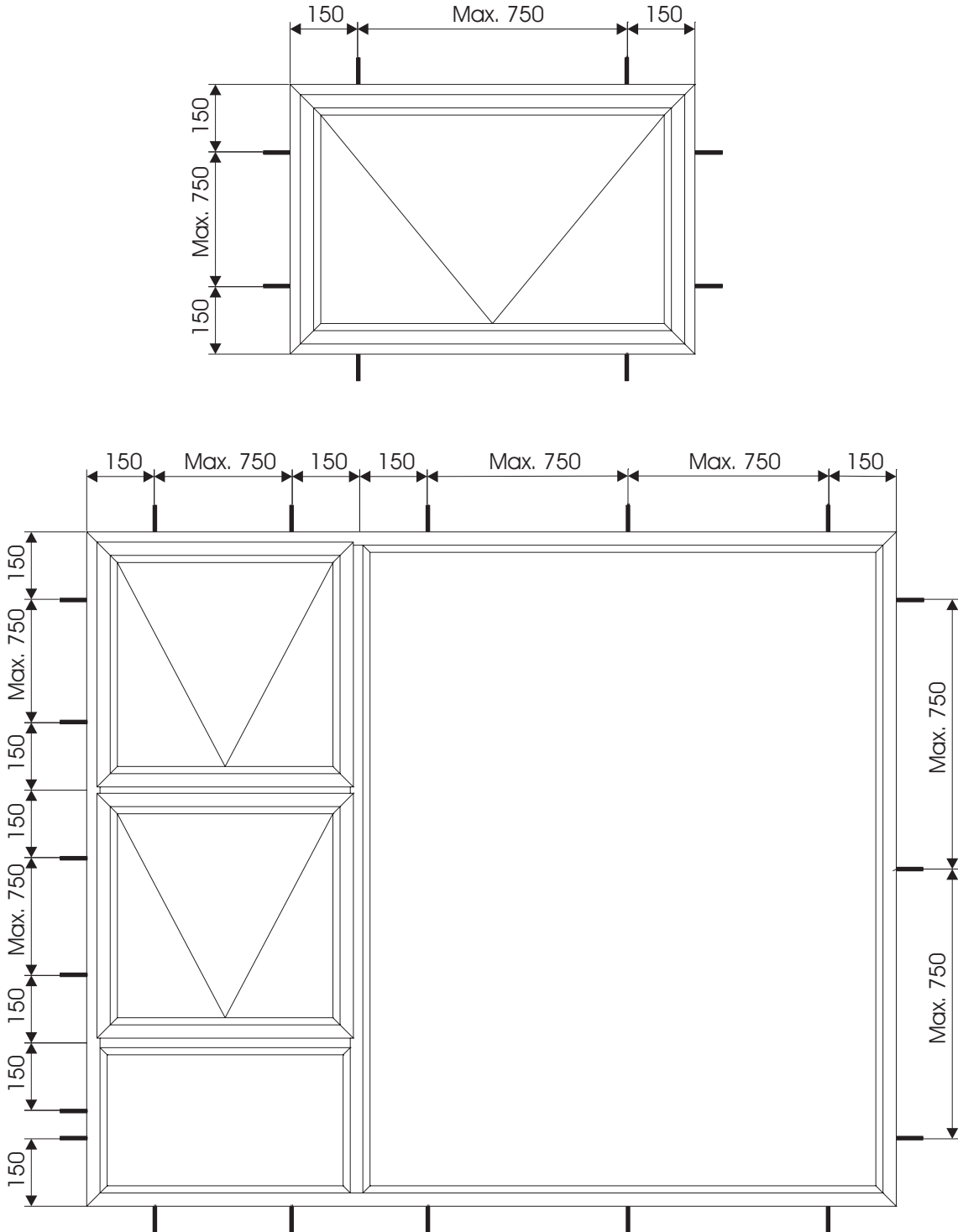

General:

The window is fixed into position - the sill is then built at a later stage - the bottom lugs can be left in place but it is often found that most times the mason either bends them out of his way or breaks them off. This practically means that most windows are only secured on 3 sides.

SHEERSASH 34 WINDOW SYSTEM TYPICAL CROSS SECTIONAL DETAIL DOUBLE TOP HUNG OVER FIXED

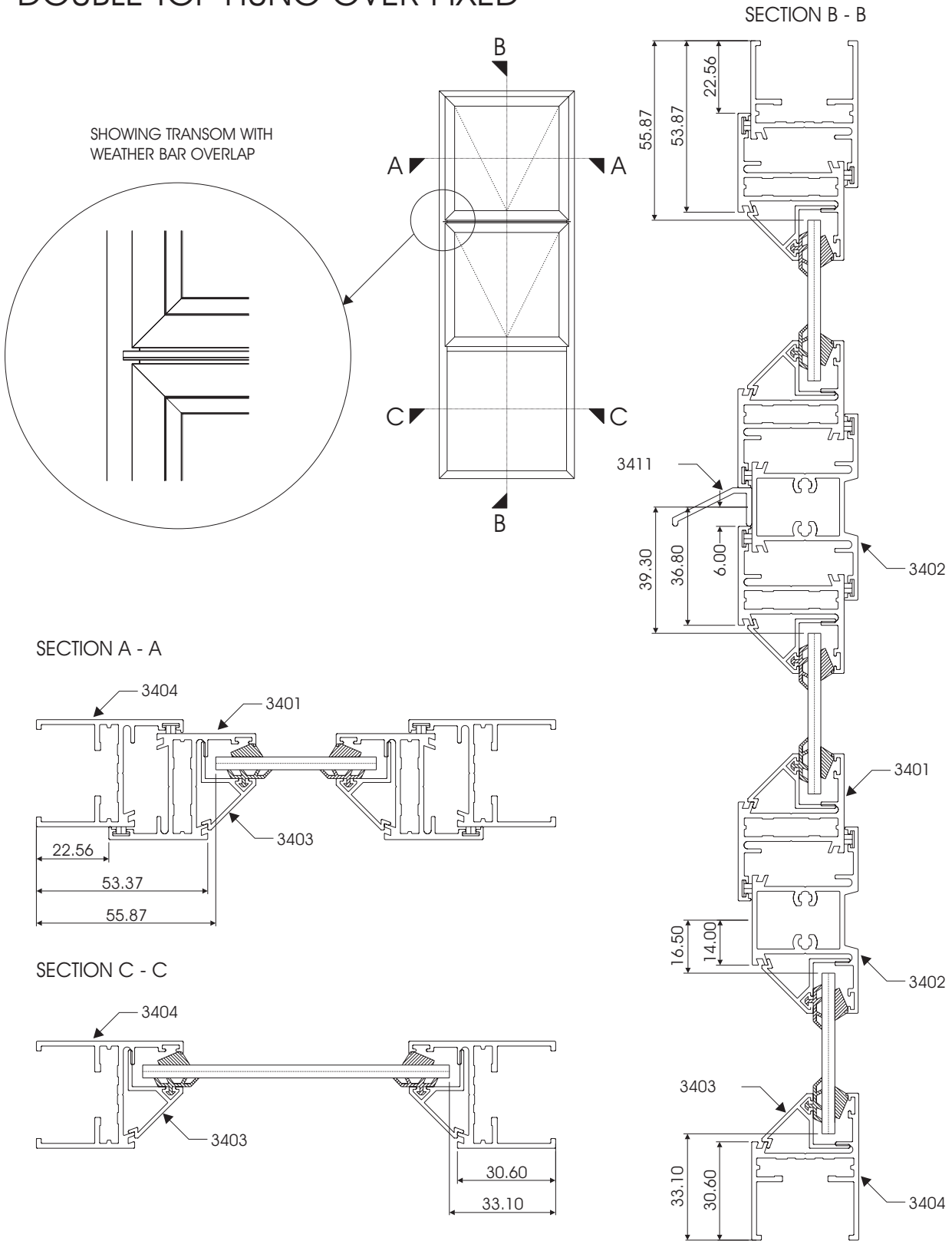

SHEERSASH 34 WINDOW SYSTEM TYPICAL CROSS SECTIONAL DETAIL SIDE HUNG OVER FIXED

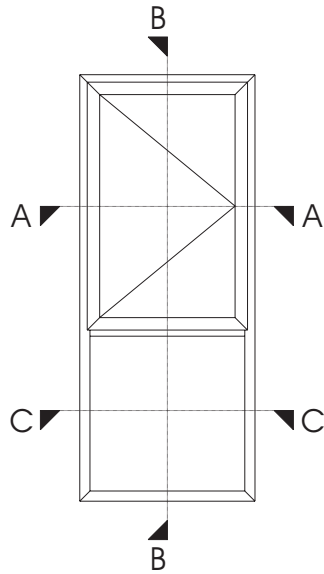

SECTION B - B

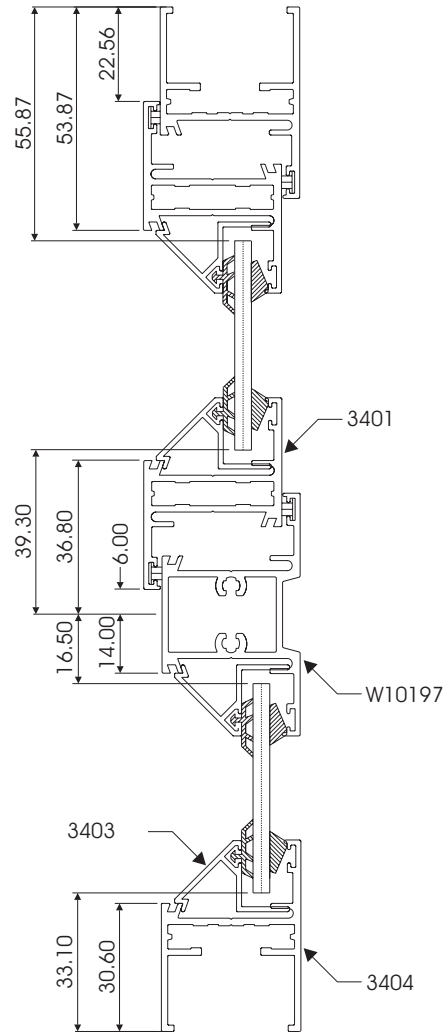

SECTION A - A

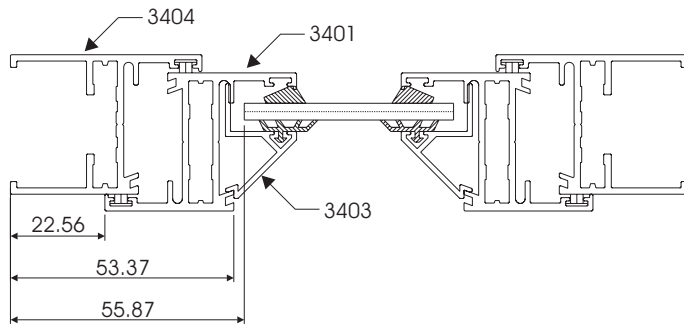

SECTION C - C

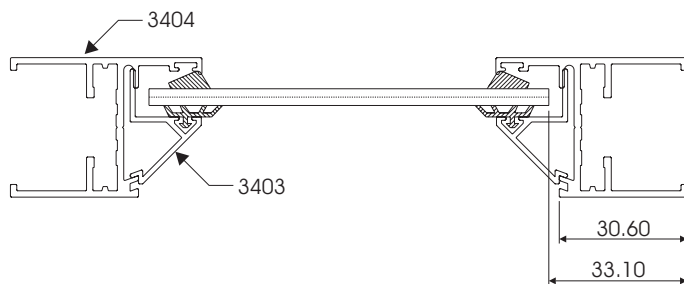

SHEERSASH 34 WINDOW SYSTEM
 COTTAGE PANE TYPICAL
 CROSS SECTIONAL DETAIL
 2 x 2 TOP HUNG OVER
 2 x 1 FIXED PANEL

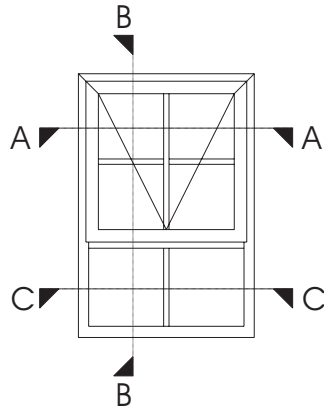

SECTION B - B

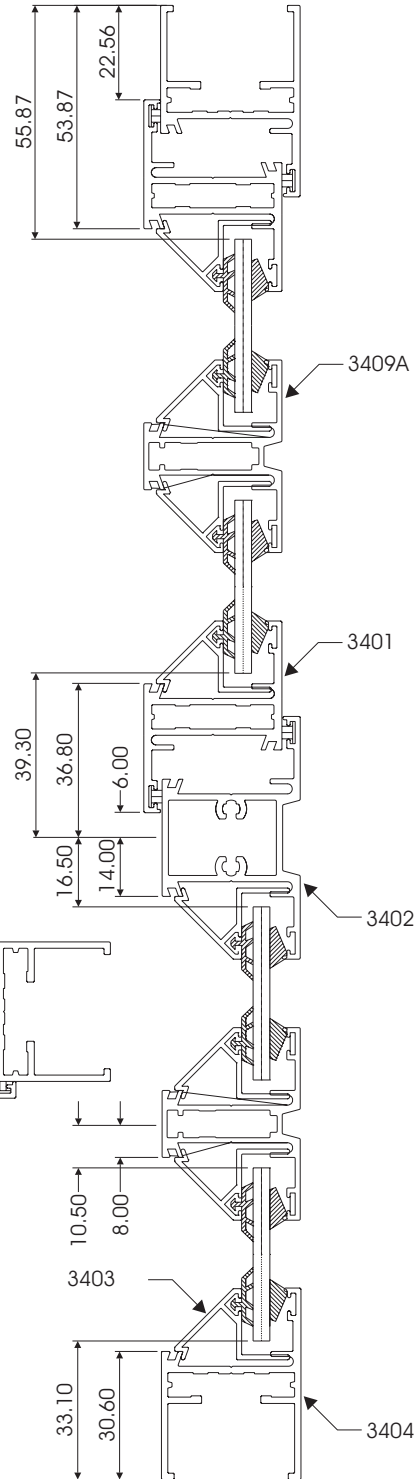

SECTION A - A

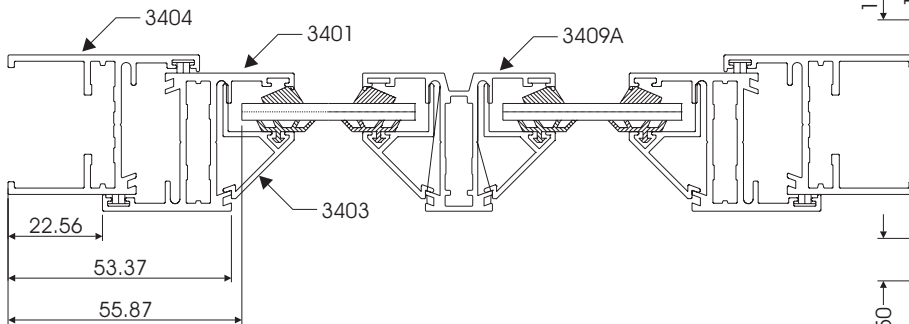

SECTION C - C

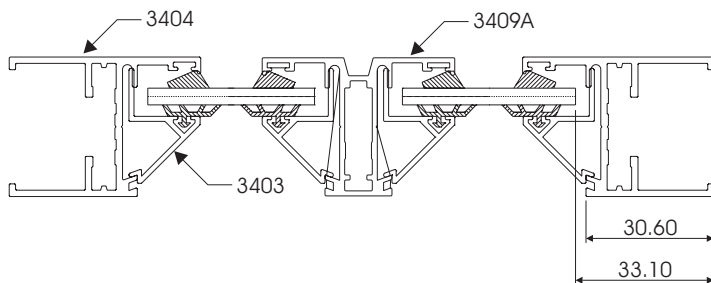

SHEERSASH 34 WINDOW SYSTEM OUTER FRAME COMPONENT ASSEMBLY DETAIL

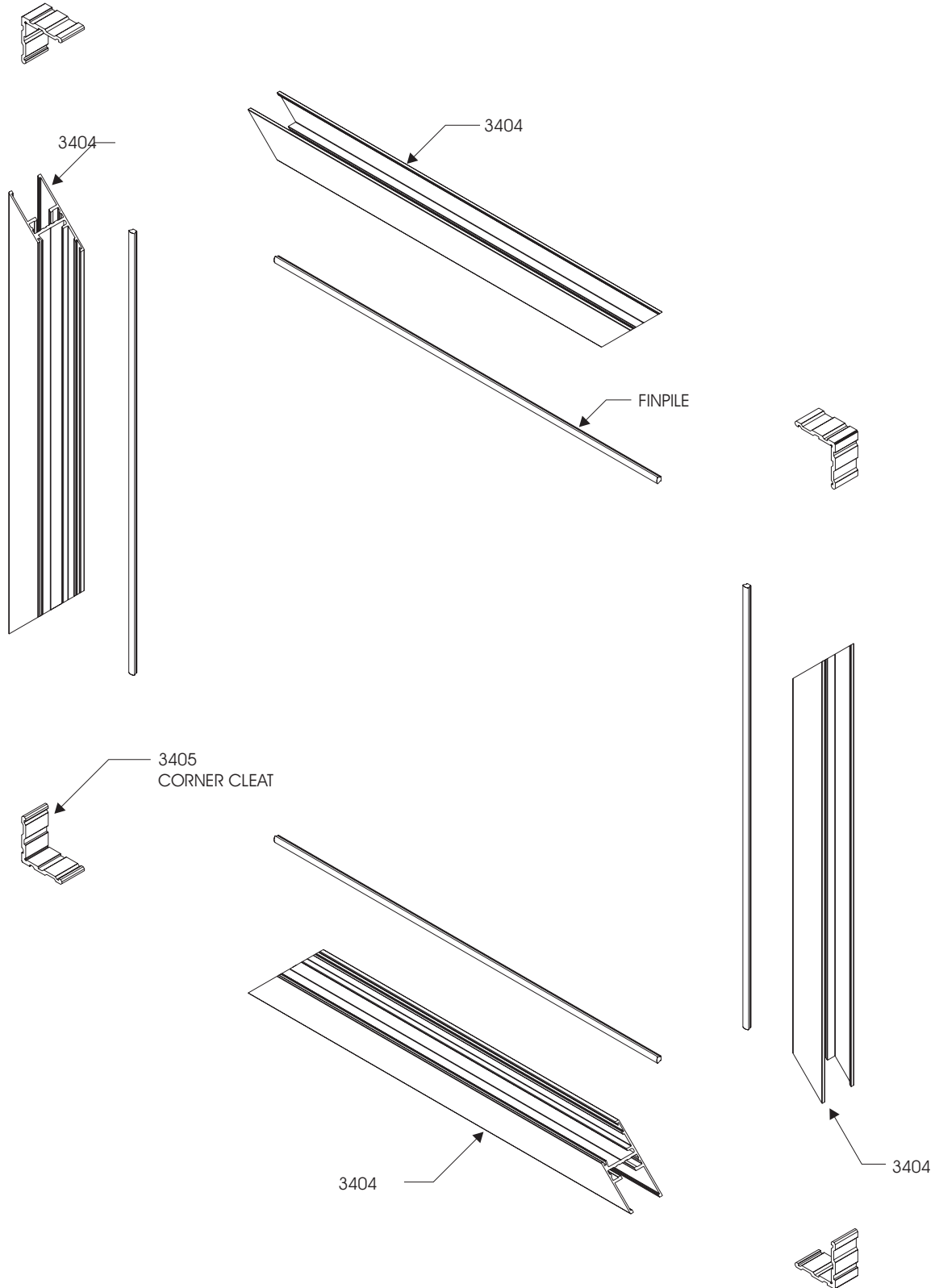

SHEERSASH 34 WINDOW SYSTEM SASH FRAME COMPONENT ASSEMBLY DETAIL

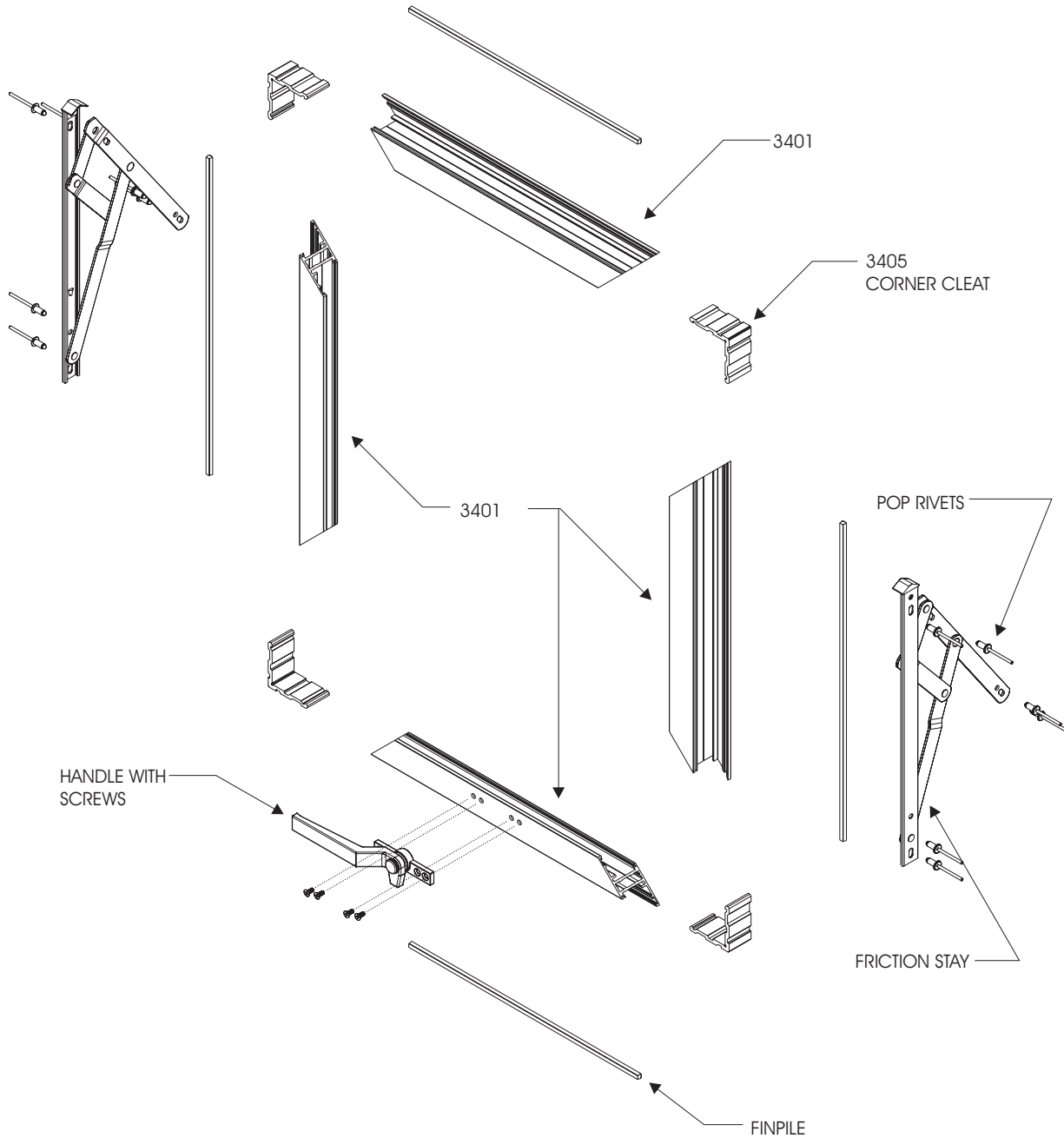

SHEERSASH 34 WINDOW SYSTEM
EQUAL LEG OUTER FRAME
SILL LEVEL & MACHINING DETAIL

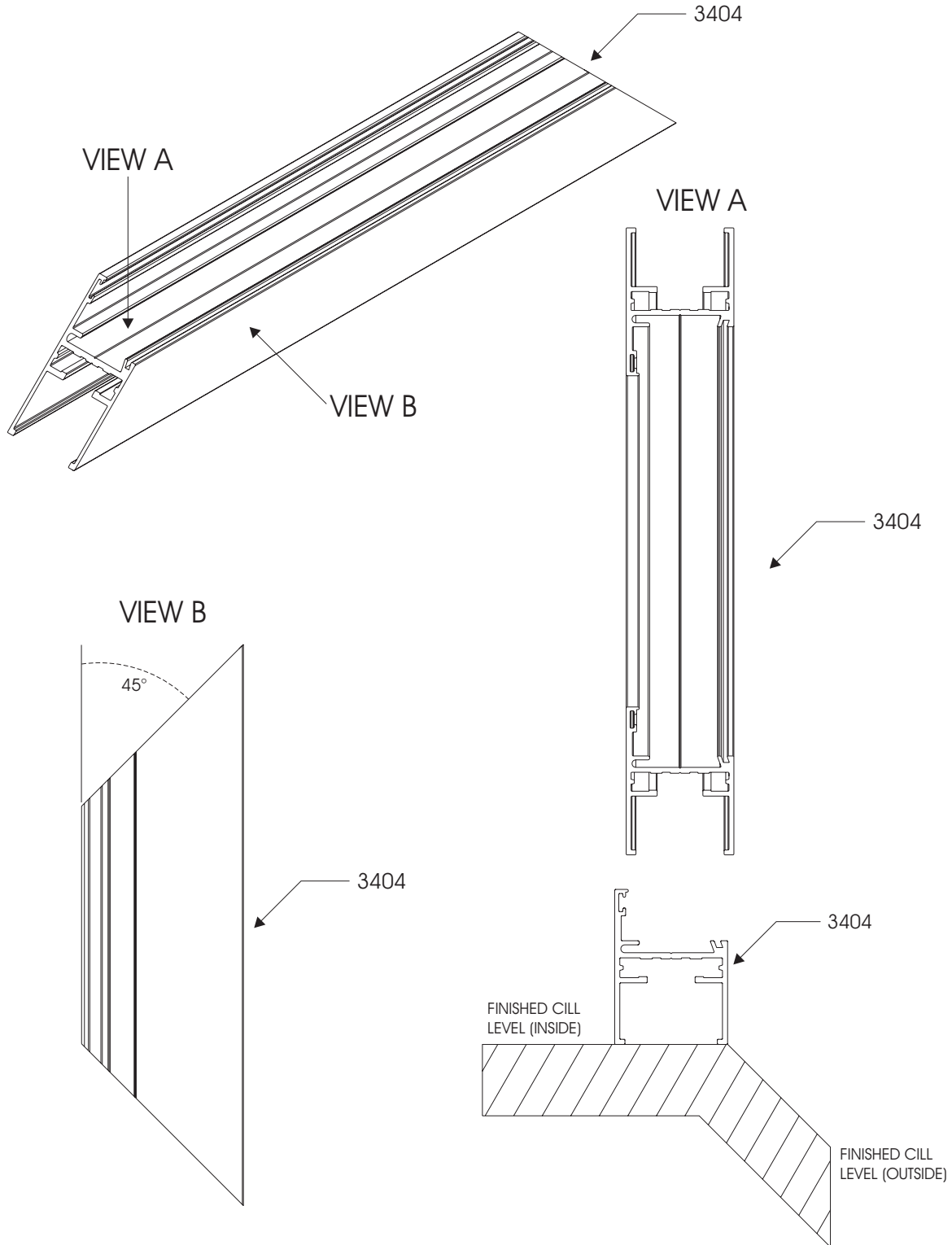

SHEERSASH 34 WINDOW SYSTEM
SHORT LEG OUTER FRAME
SILL LEVEL & MACHINING DETAIL

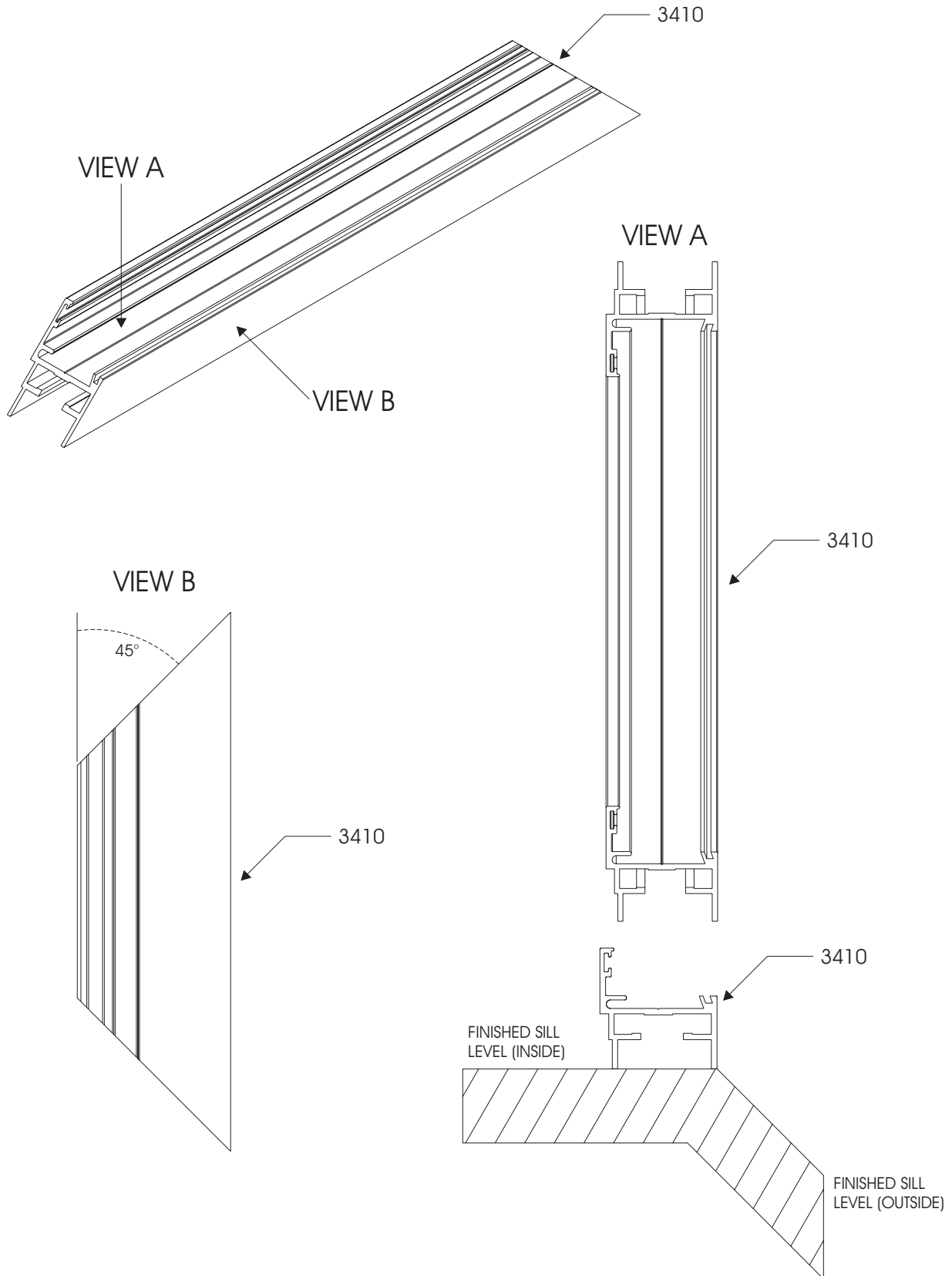

SHEERSASH 34 WINDOW SYSTEM
 SIDELIGHT FRAME 72mm
 SILL LEVEL & MACHINING DETAIL

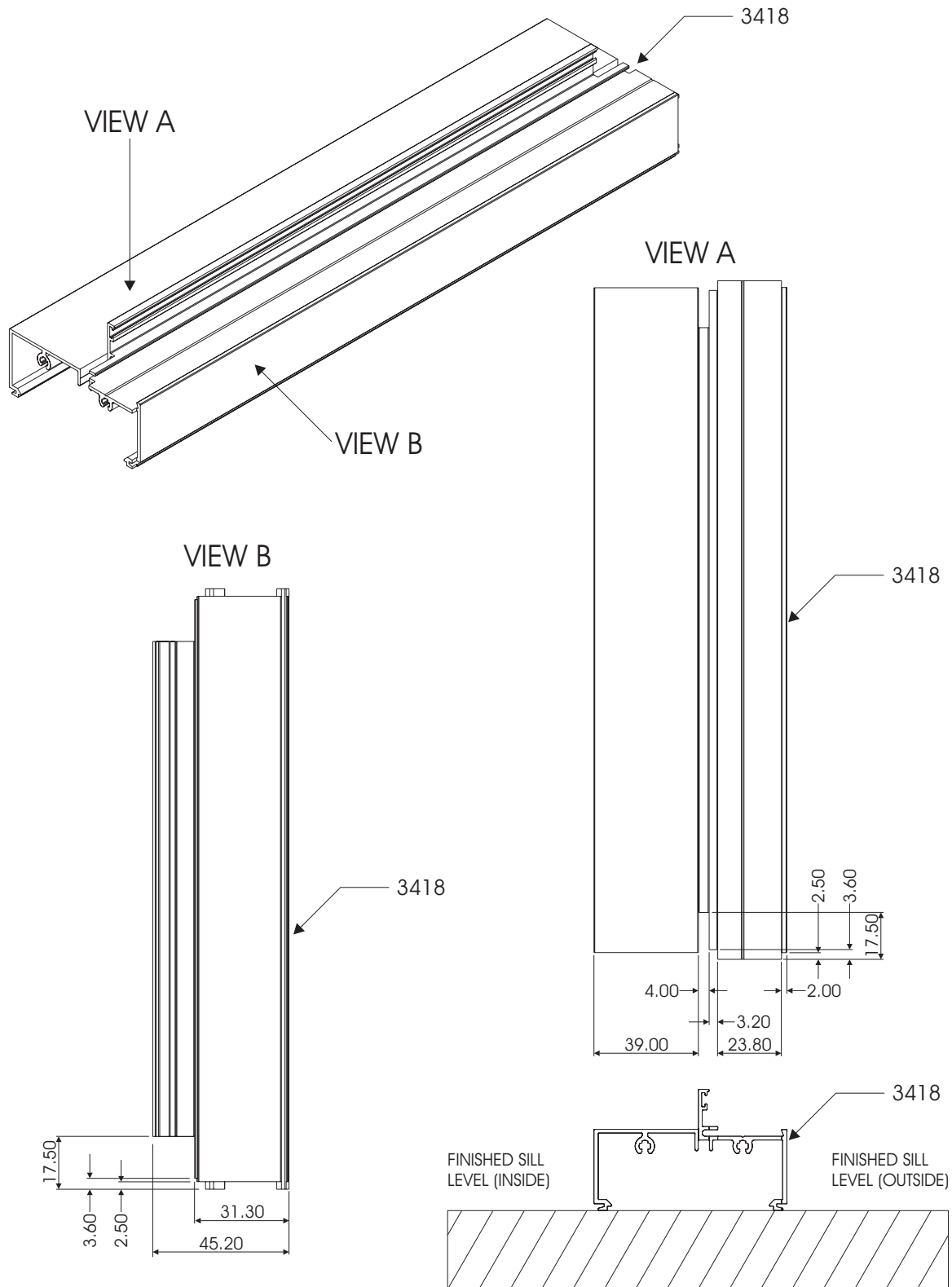

SHEERSASH 34 WINDOW SYSTEM
 SIDELIGHT BOX SILL 72mm
 SILL LEVEL & MACHINING DETAIL

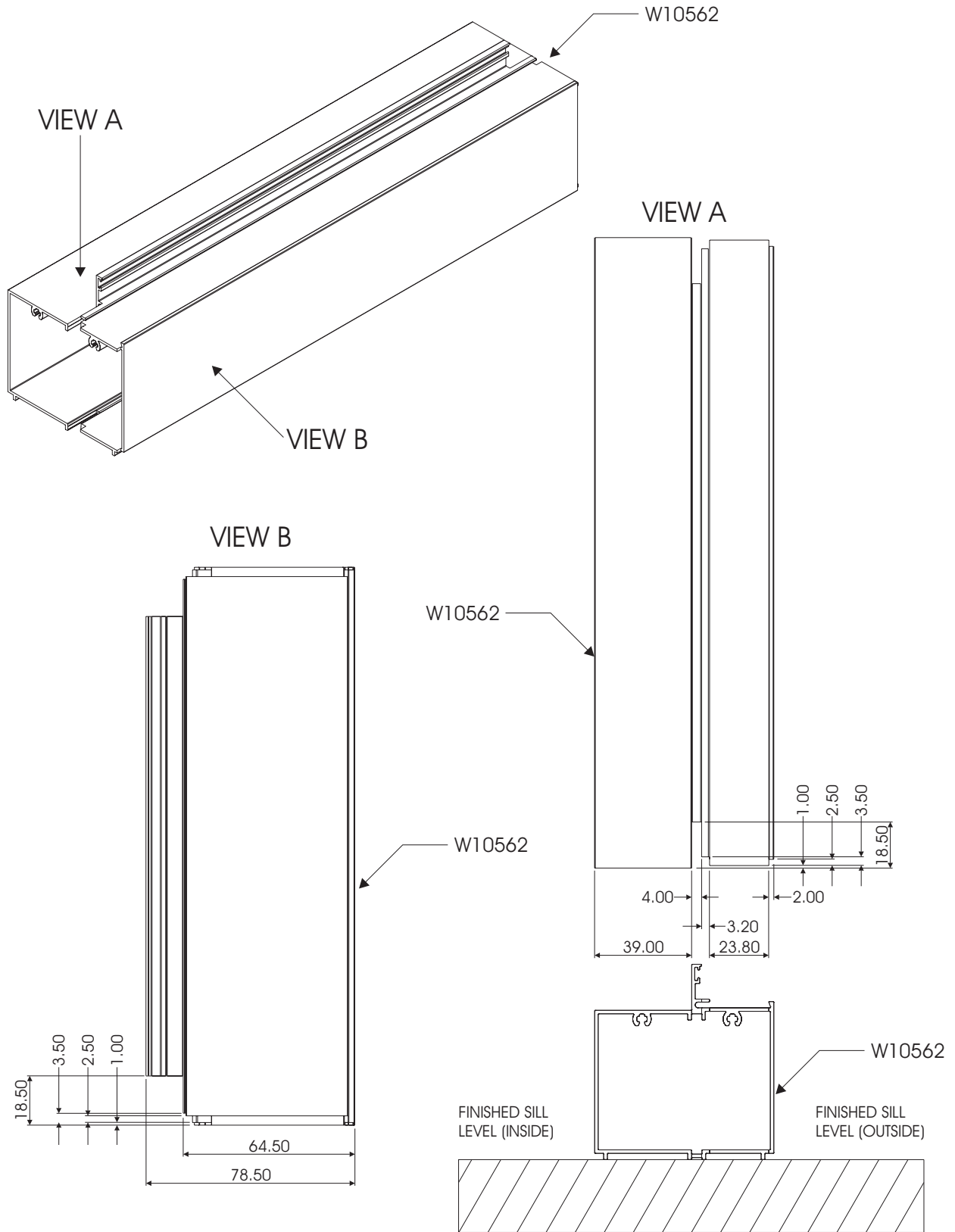

SHEERSASH 34 WINDOW SYSTEM
 STANDARD MULLION MACHINING
 DETAIL FOR END MILLING
 ON EQUAL LEG OUTER FRAME

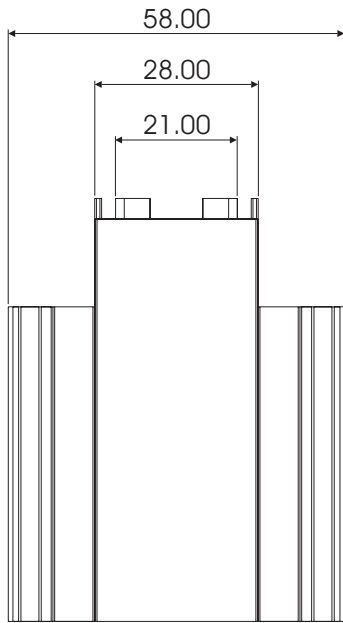
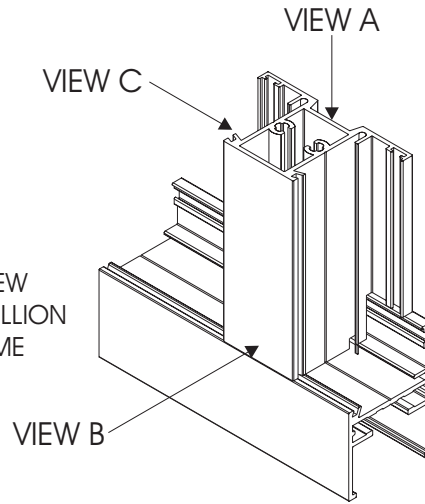
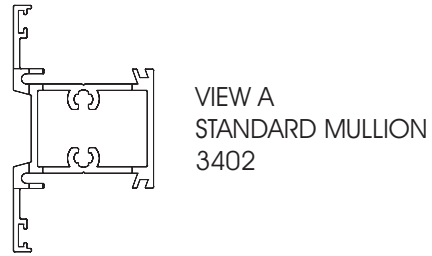
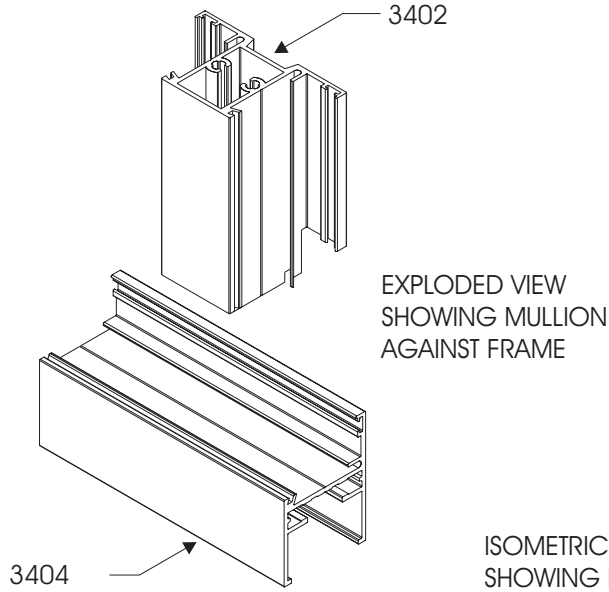

VIEW B

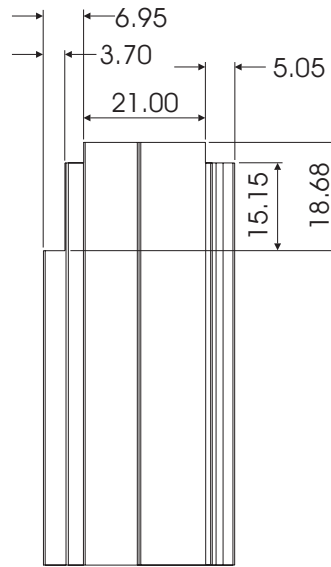

VIEW C

SHEERSASH 34 WINDOW SYSTEM
 STANDARD MULLION MACHINING
 DETAIL FOR END MILLING
 ON SHORT LEG OUTER FRAME

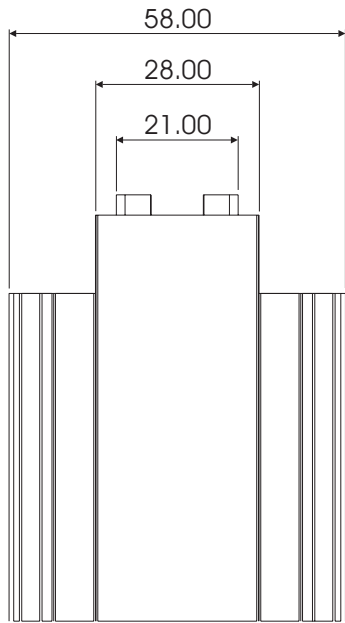
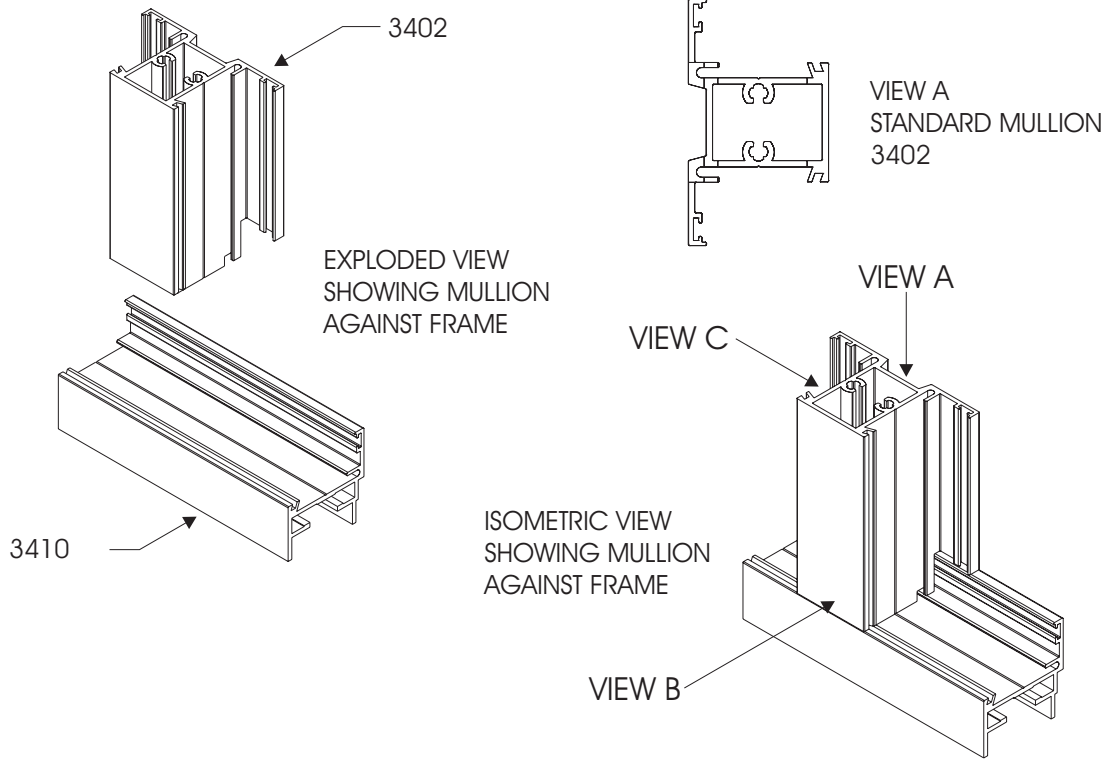

VIEW B

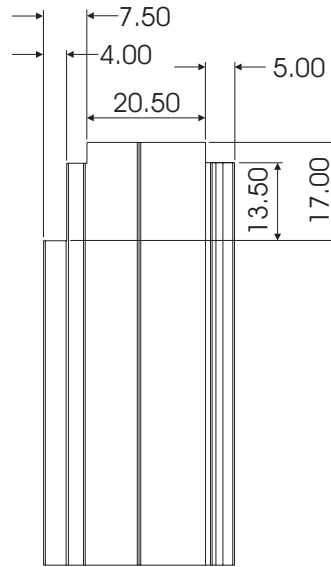

VIEW C

SHEERSASH 34 WINDOW SYSTEM
 STANDARD MULLION MACHINING
 DETAIL FOR END MILLING
 ON SIDELIGHT FRAME 72mm

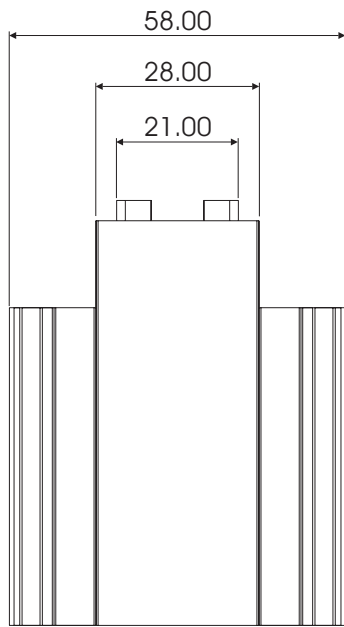
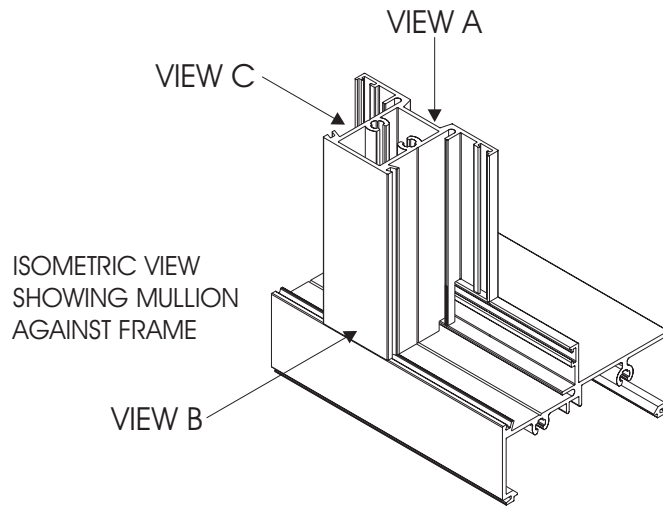
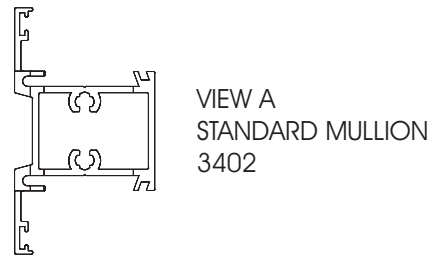
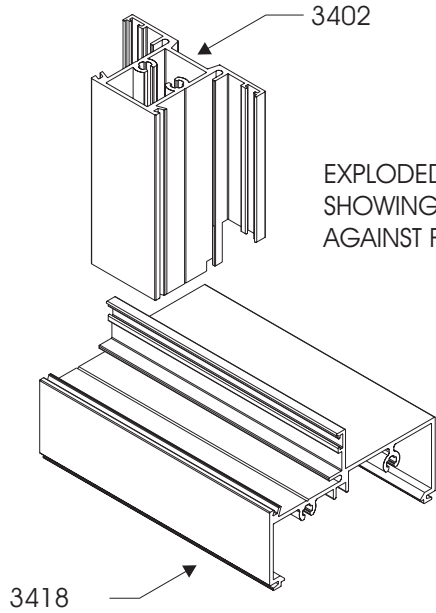

VIEW B

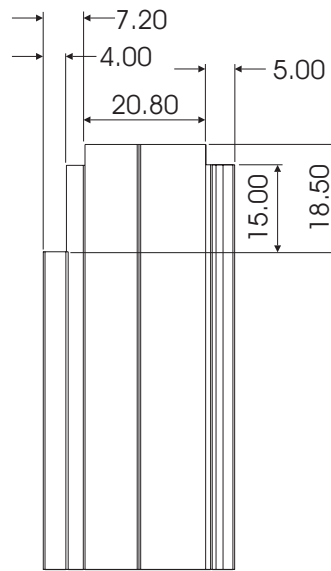

VIEW C

SHEERSASH 34 WINDOW SYSTEM
 STANDARD MULLION MACHINING
 DETAIL FOR END MILLING
 ON SIDELIGHT BOX SILL 72mm

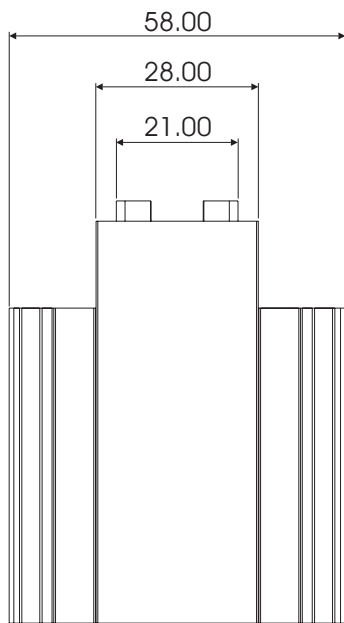
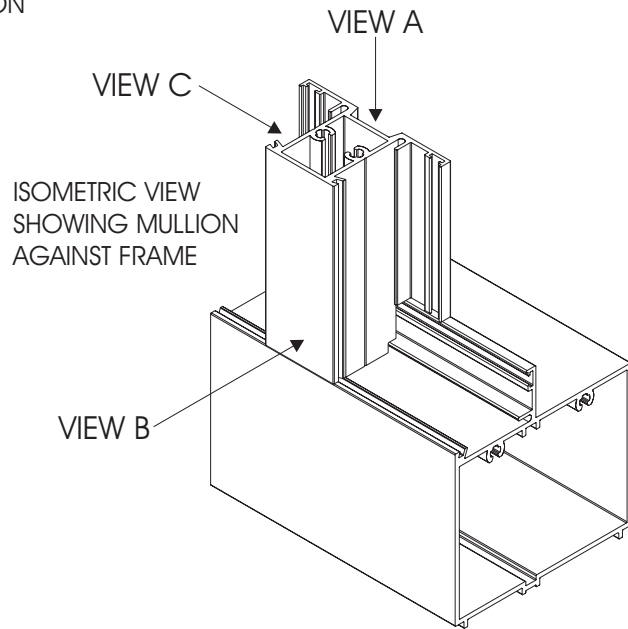
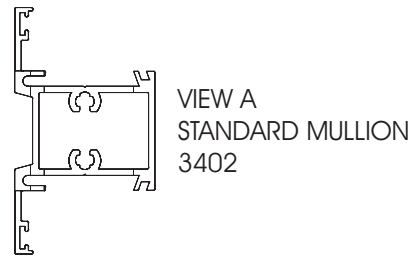
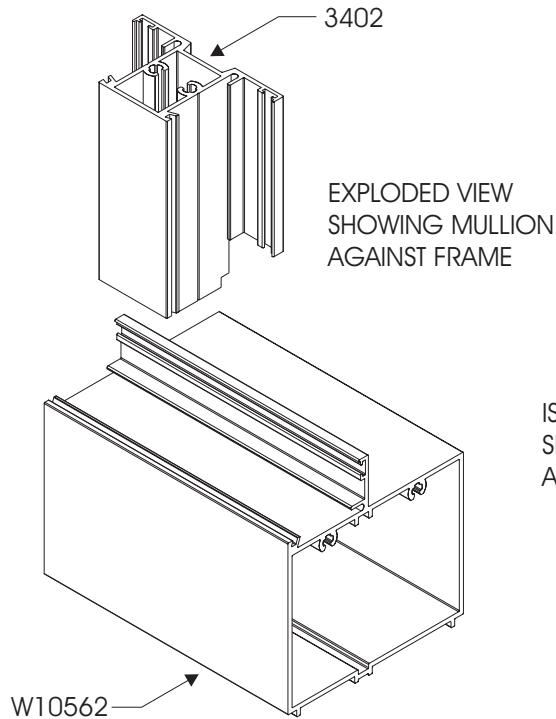

VIEW B

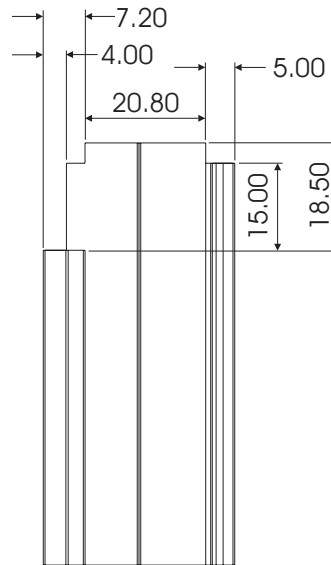

VIEW C

SHEERSASH 34 WINDOW SYSTEM
 COTTAGE PANE MULLION
 MACHINING DETAIL FOR END MILLING
 ON EQUAL LEG OUTER FRAME

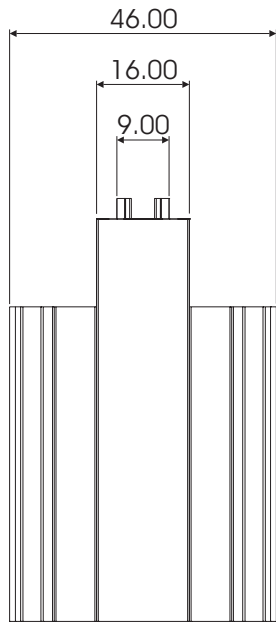
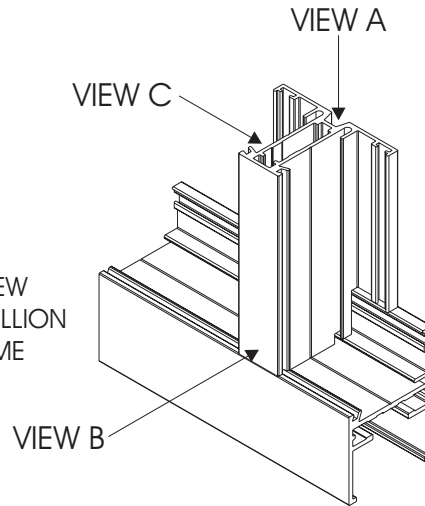
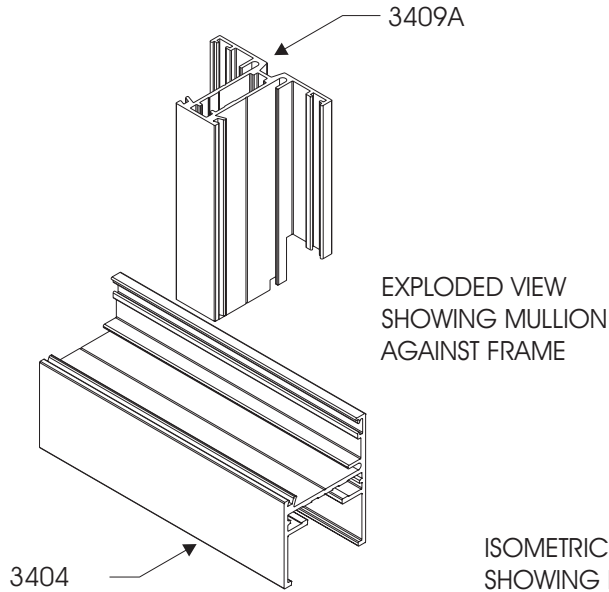

VIEW B

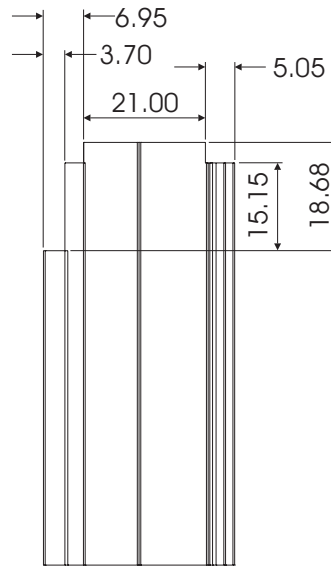

VIEW C

SHEERSASH 34 WINDOW SYSTEM
 COTTAGE PANE MULLION
 MACHINING DETAIL FOR END MILLING
 ON SHORT LEG OUTER FRAME

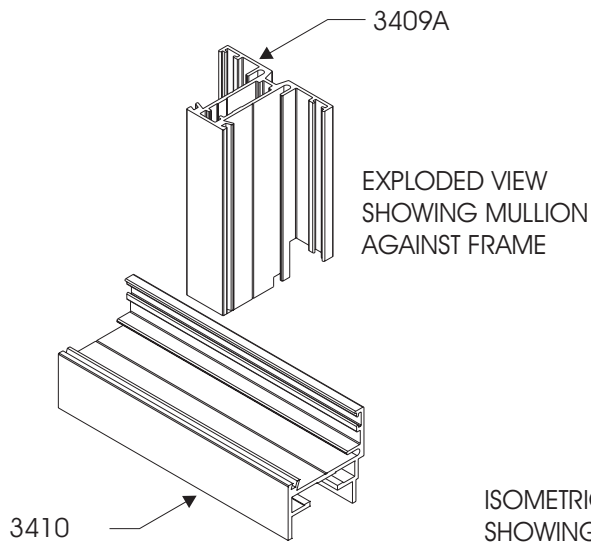

ISOMETRIC VIEW
 SHOWING MULLION
 AGAINST FRAME

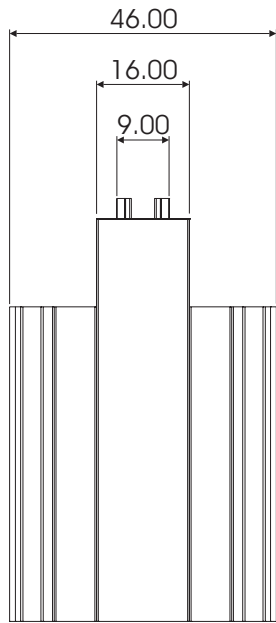
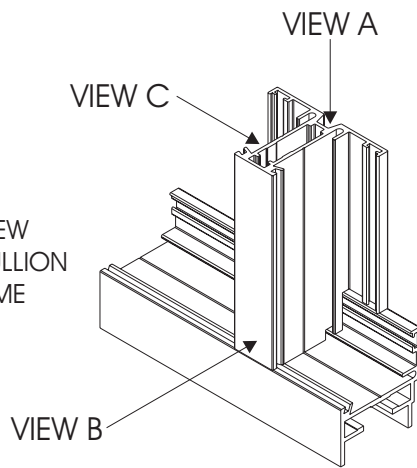

VIEW B

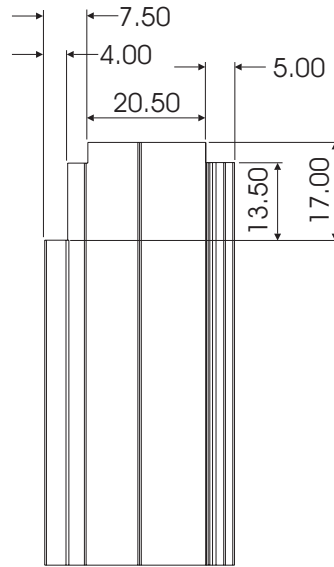

VIEW C

SHEERSASH 34 WINDOW SYSTEM
 COTTAGE PANE MULLION
 MACHINING DETAIL FOR END MILLING
 ON SIDELIGHT FRAME 72mm

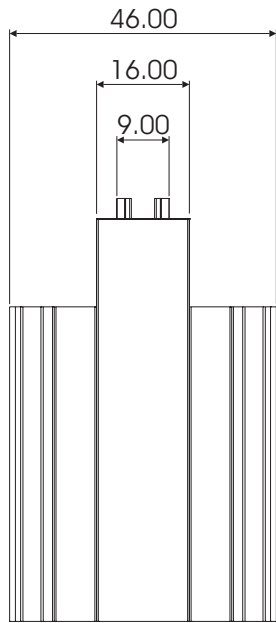
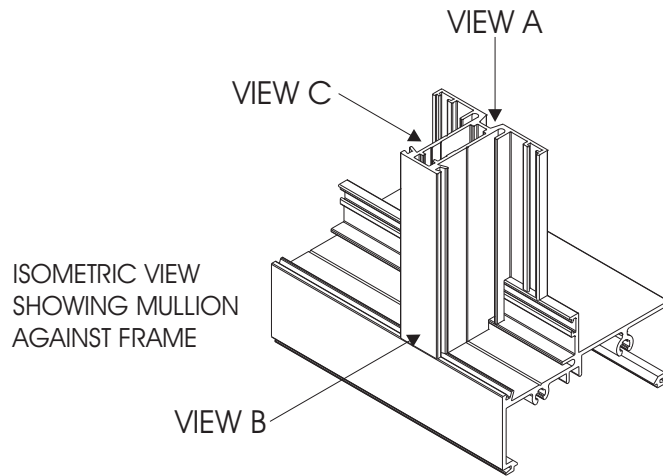
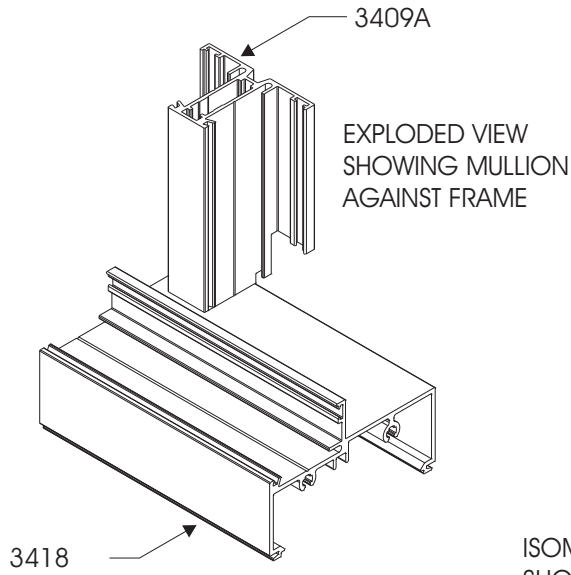

VIEW B

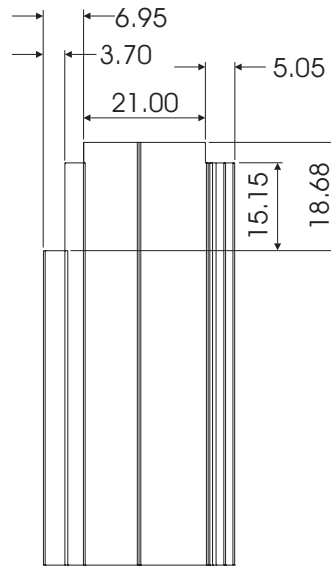

VIEW C

SHEERSASH 34 WINDOW SYSTEM
 COTTAGE PANE MULLION
 MACHINING DETAIL FOR END MILLING
 ON SIDELIGHT BOX SILL 72mm

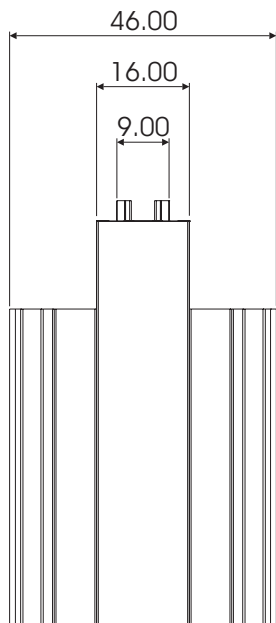
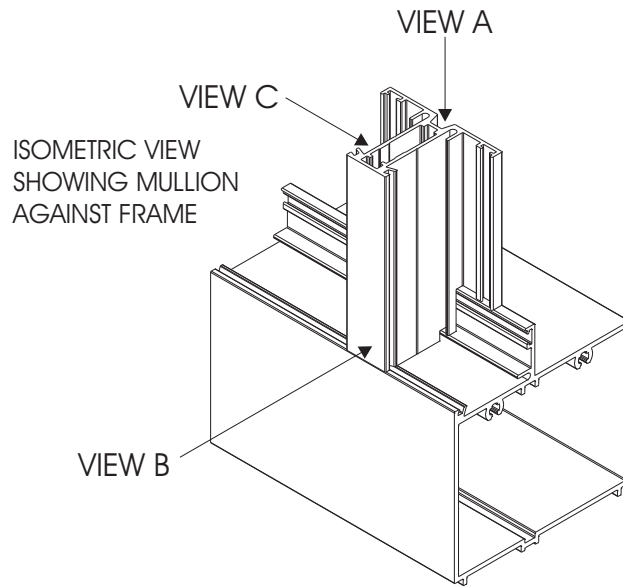
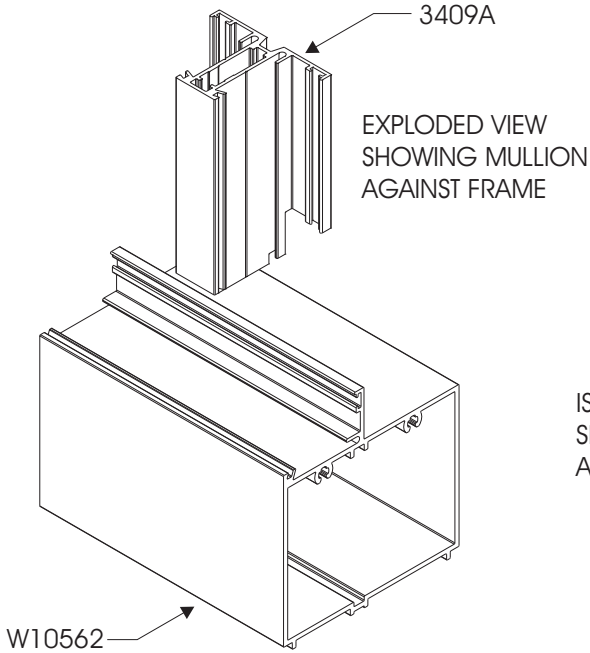

VIEW B

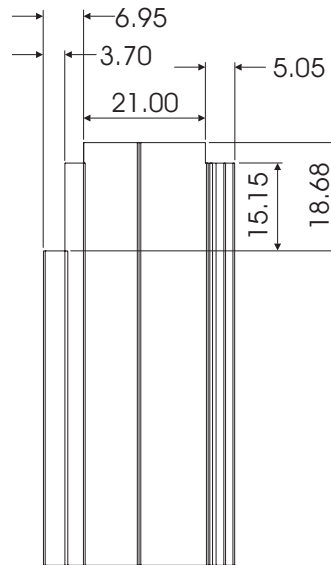

VIEW C

SHEERSASH 34 WINDOW SYSTEM CORNER CLEAT ASSEMBLY DETAIL FOR TUBULAR SASH

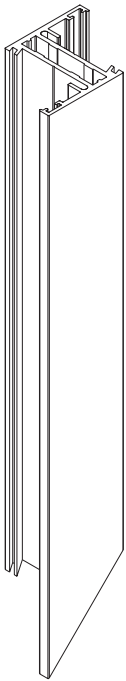

NOTE:
ALL JOINTS MUST BE SEALED WITH
SMALL JOINT SEALANT. WOOLPILE
MUST BE FITTED TO SASH AND
CORRESPONDING SURFACES OF
FRAME BEFORE CRIMPING (NOT
TO AREAS TO BE GLAZED)

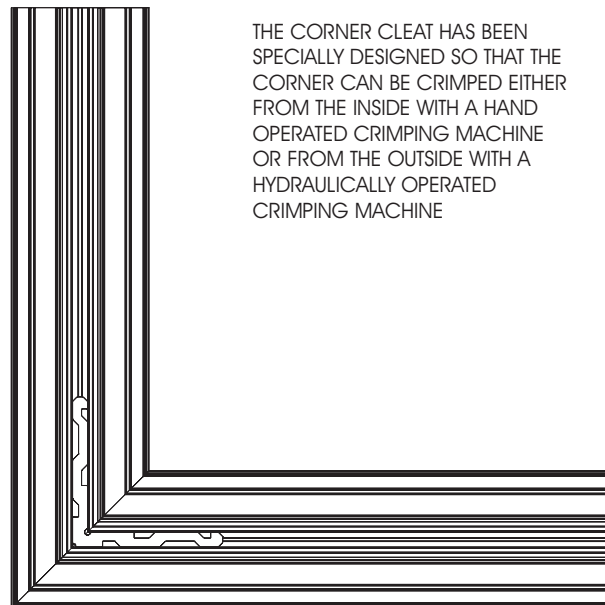
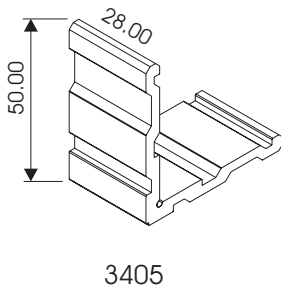
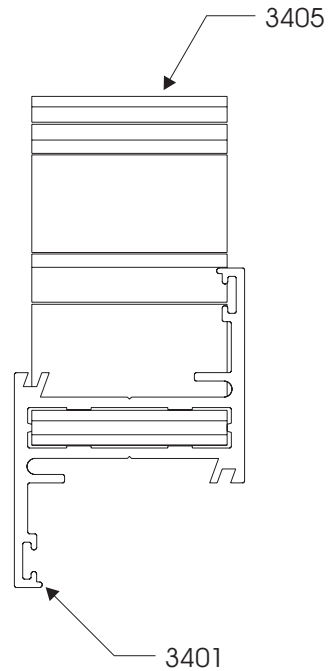
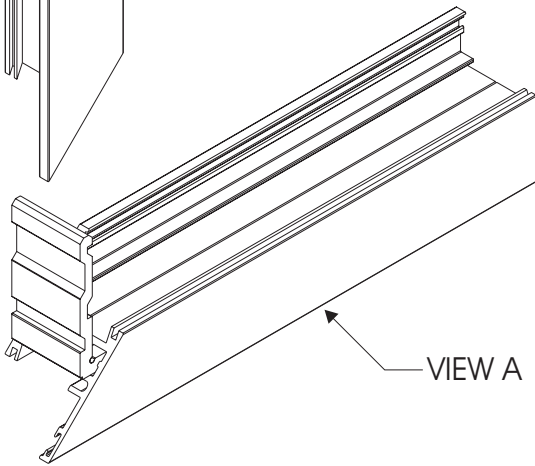

THE CORNER CLEAT HAS BEEN
SPECIALLY DESIGNED SO THAT THE
CORNER CAN BE CRIMPED EITHER
FROM THE INSIDE WITH A HAND
OPERATED CRIMPING MACHINE
OR FROM THE OUTSIDE WITH A
HYDRAULICALLY OPERATED
CRIMPING MACHINE

VIEW A

SHEERSASH 34 WINDOW SYSTEM GLAZING BAR FRAME JOINT ASSEMBLY DETAIL



NOTE: ALL JOINTS MUST BE SEALED WITH SMALL JOINT SEALANT. FINPILE MUST BE FITTED PRIOR TO ASSEMBLY IF SASH IS TO BE FITTED INTO FRAME. FINPLIE MUST NOT RUN BEHIND GLAZING BAR AND GAP MUST BE SEALED TO PREVENT WATER INFILTRATION.

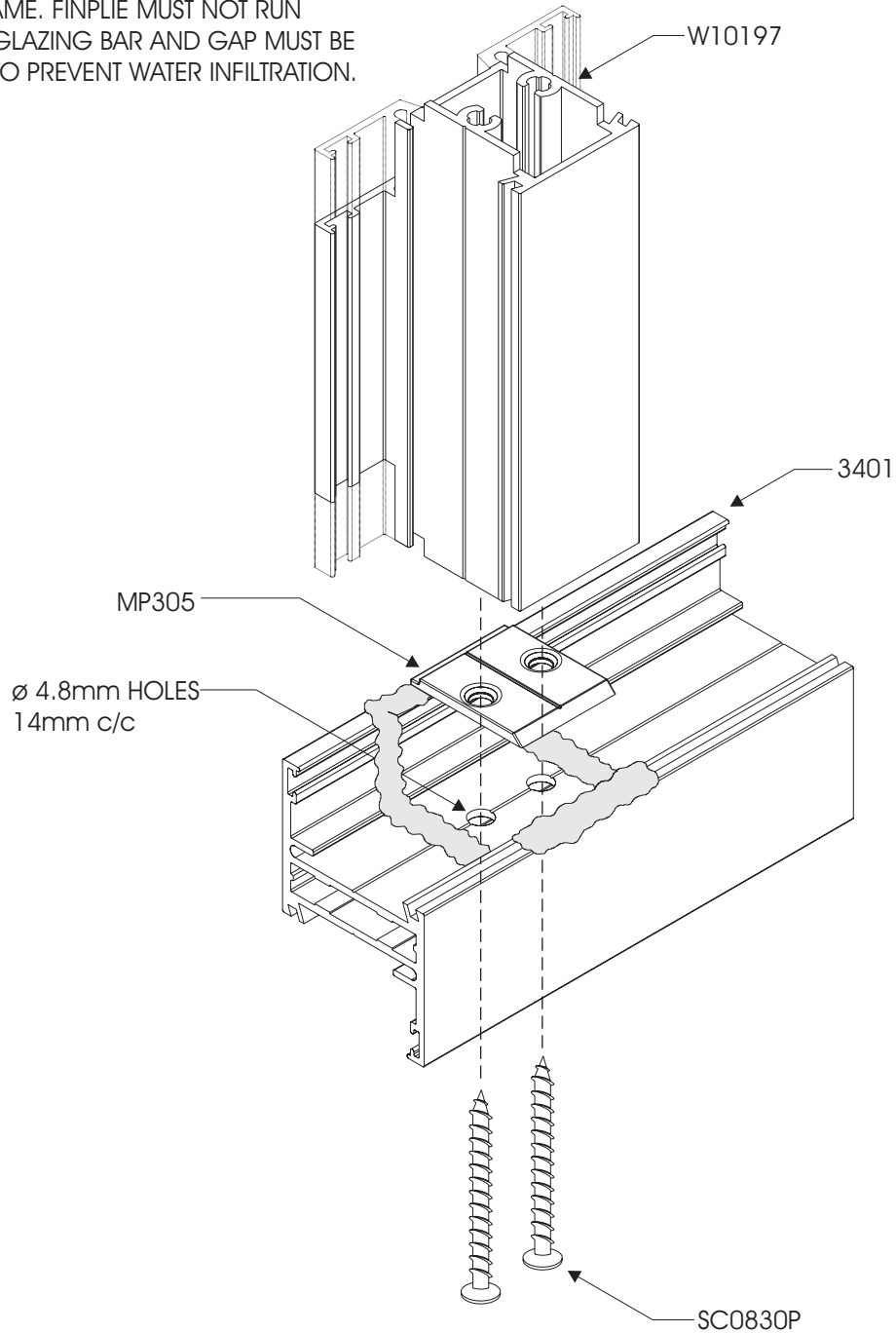

SHEERSASH 34 WINDOW SYSTEM CROSS JOINT ASSEMBLY DETAIL STANDARD MULLION

NOTE: ALL JOINTS MUST BE SEALED WITH SMALL JOINT SEALANT. FINPILE MUST BE FITTED PRIOR TO ASSEMBLY IF SASH IS TO BE FITTED INTO FRAME. FINPILE MUST NOT RUN BEHIND GLAZING BAR AND GAP MUST BE SEALED TO PREVENT WATER INFILTRATION.

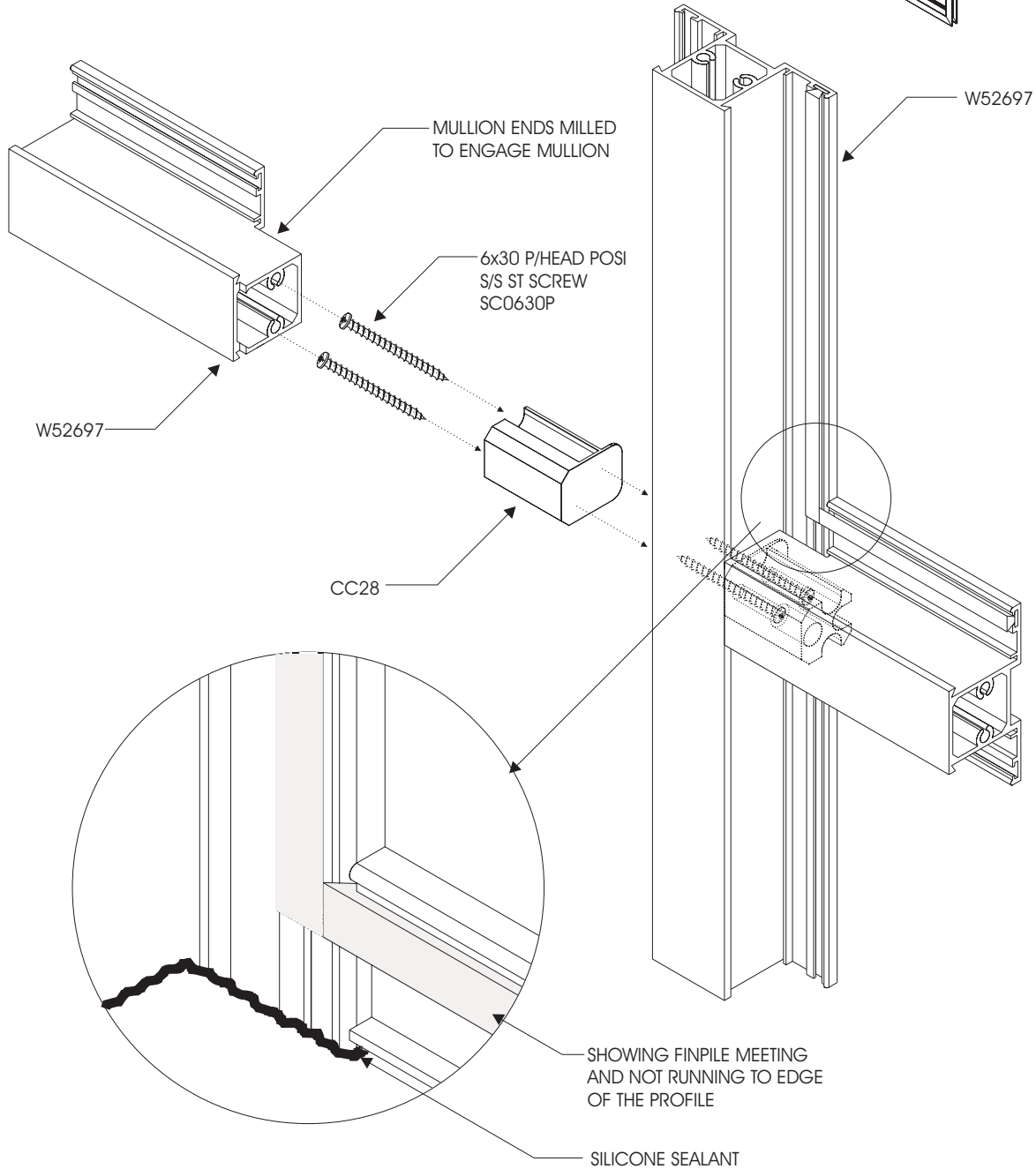
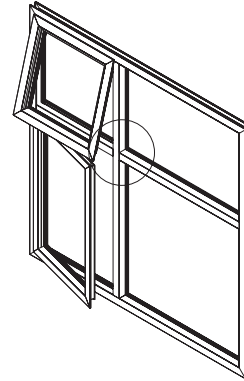

SHEERSASH 34 WINDOW SYSTEM CROSS JOINT ASSEMBLY DETAIL COTTAGE PANE MULLION

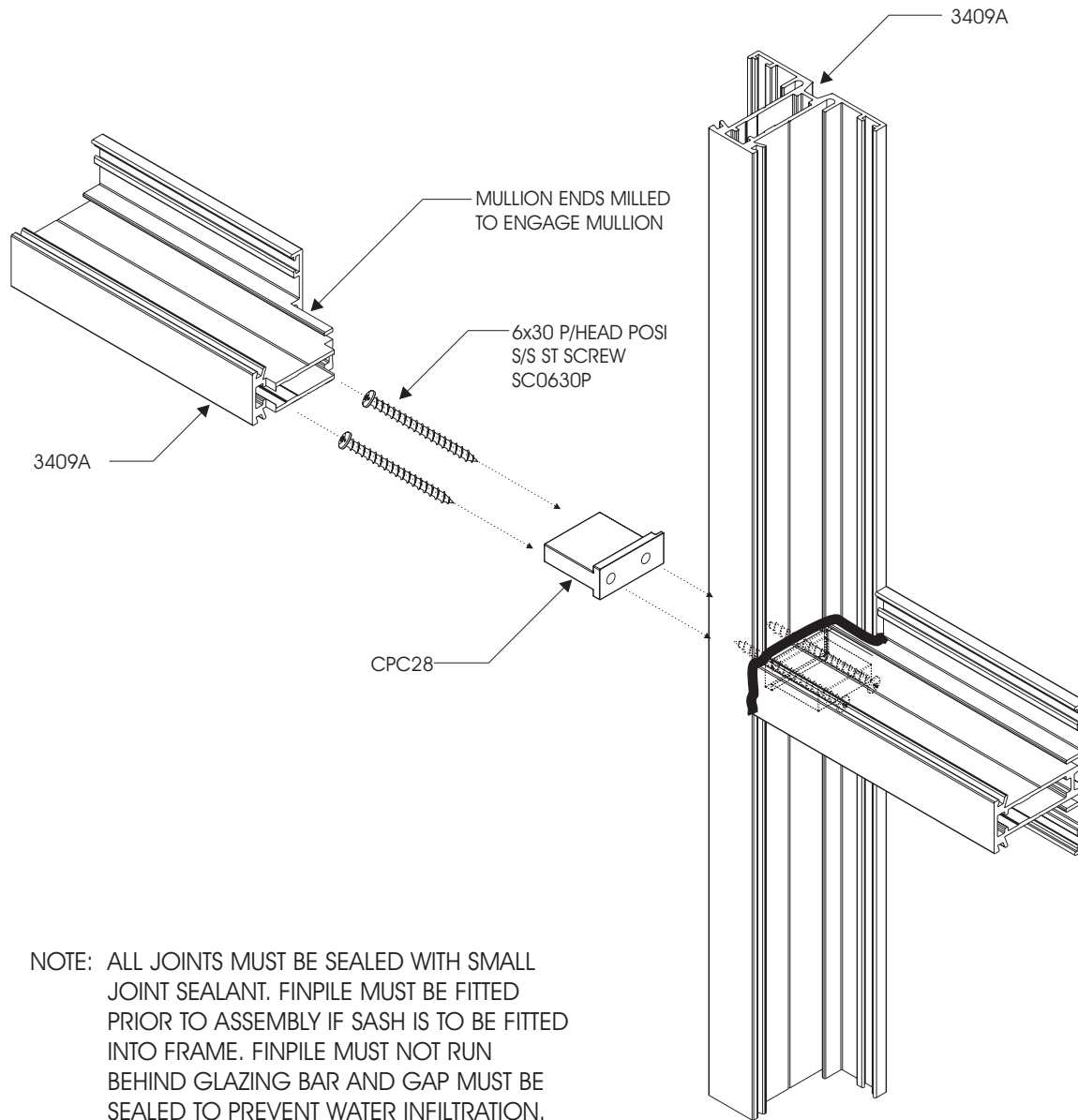

SHEERSASH 34 WINDOW SYSTEM GLAZING PROCEDURE

Insert the pull-in vinyl gasket into glazing beads by sliding or pressing it into the groove (1). Before cutting gasket, ensure that it has not stretched and cut 6mm longer so that corners are in compression at all times.

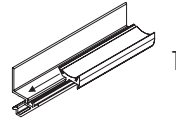

Position bottom glazing bead in glazing bead rebate (2).

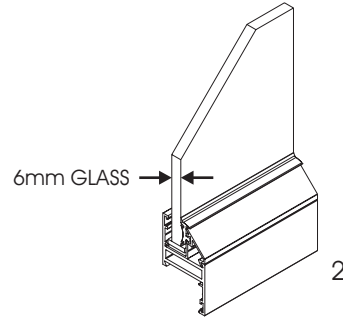

Place glass on glazing blocks (3).

Insert top and then side glazing beads ensuring that they are in correctly.

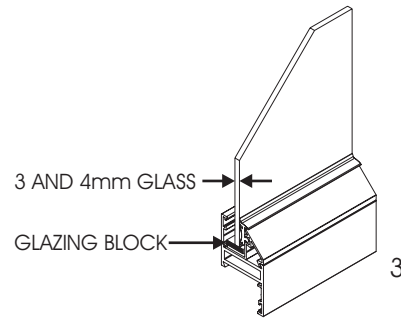

Starting from top centre, insert roll in gasket (4) without stretching it (5). Stop 150mm from corner and partly cut gasket 6mm longer than the edge of the vertical bead. Insert gasket at corner and then roll in remaining 150mm. Repeat this on the other sides. Where gasket ends meet, cut gasket 6mm longer. Insert cut ends first and complete.

ENSURE GASKETS ARE NOT STRETCHED AT ANY STAGE

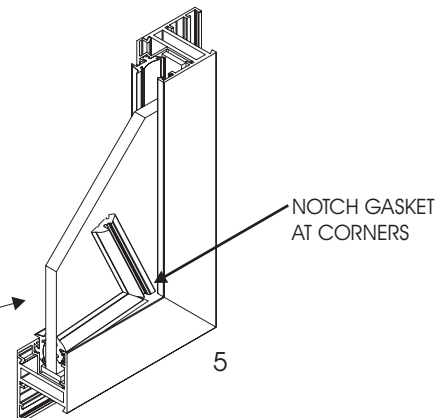
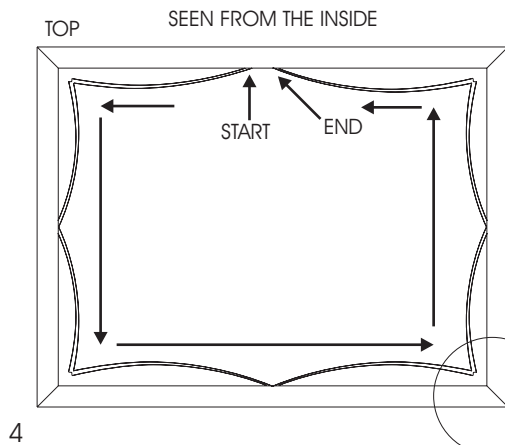

GLAZING

1. SELECTION OF GLAZING METHODS

1.1 SETTING AND LOCATION BLOCKS

Glass-to-metal contact must be avoided at all times by using setting and location blocks having a hardness of 50° to 90° shore A durometer. Use only blocks made of Neoprene, EPDM, Silicone or other elastomeric material.

Setting blocks are to have a minimum thickness of 3mm and must be at least 27mm in length per square metre of glass area.

In the event of laminated glass and/or sealed insulated glass units drainage is to be provided to prevent the glass edge to be submerged. Two or more 7mm diameter holes or 5mm x 9mm slotted holes, or larger, are to be equally spaced in the sill section of sash or frame to allow for such ventilation/drainage.

The position of the setting and location blocks is illustrated in Figure 2.

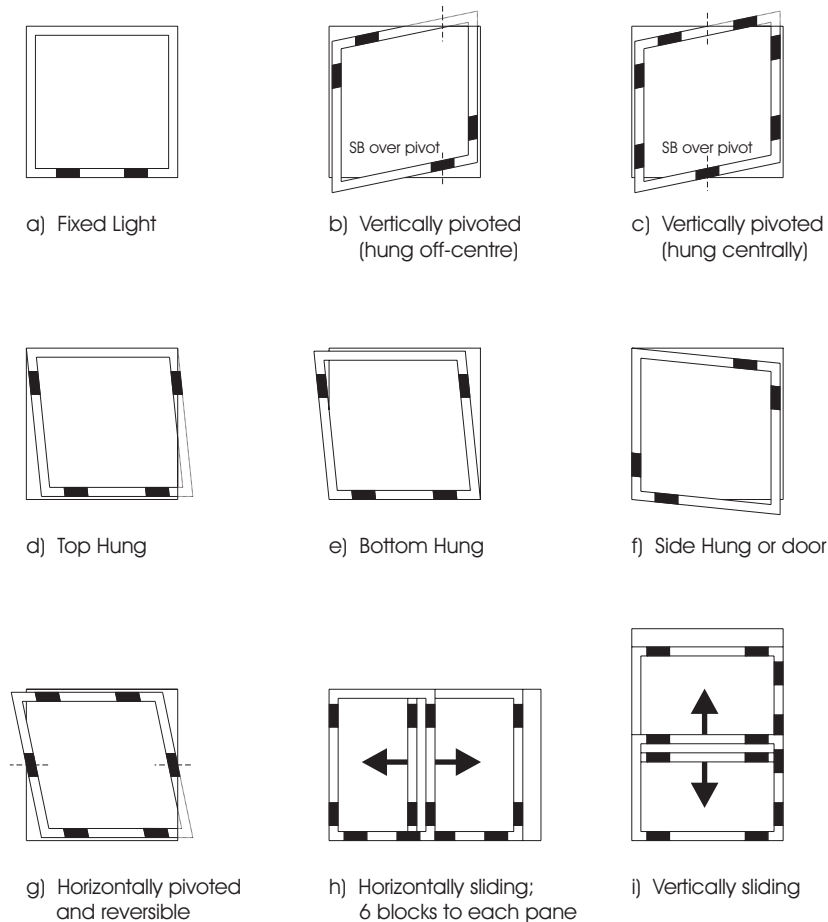
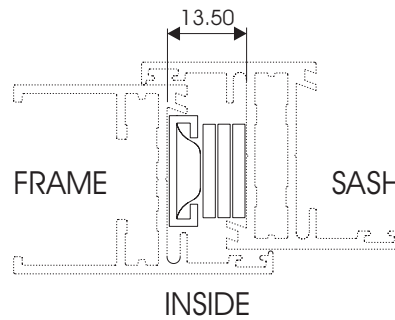
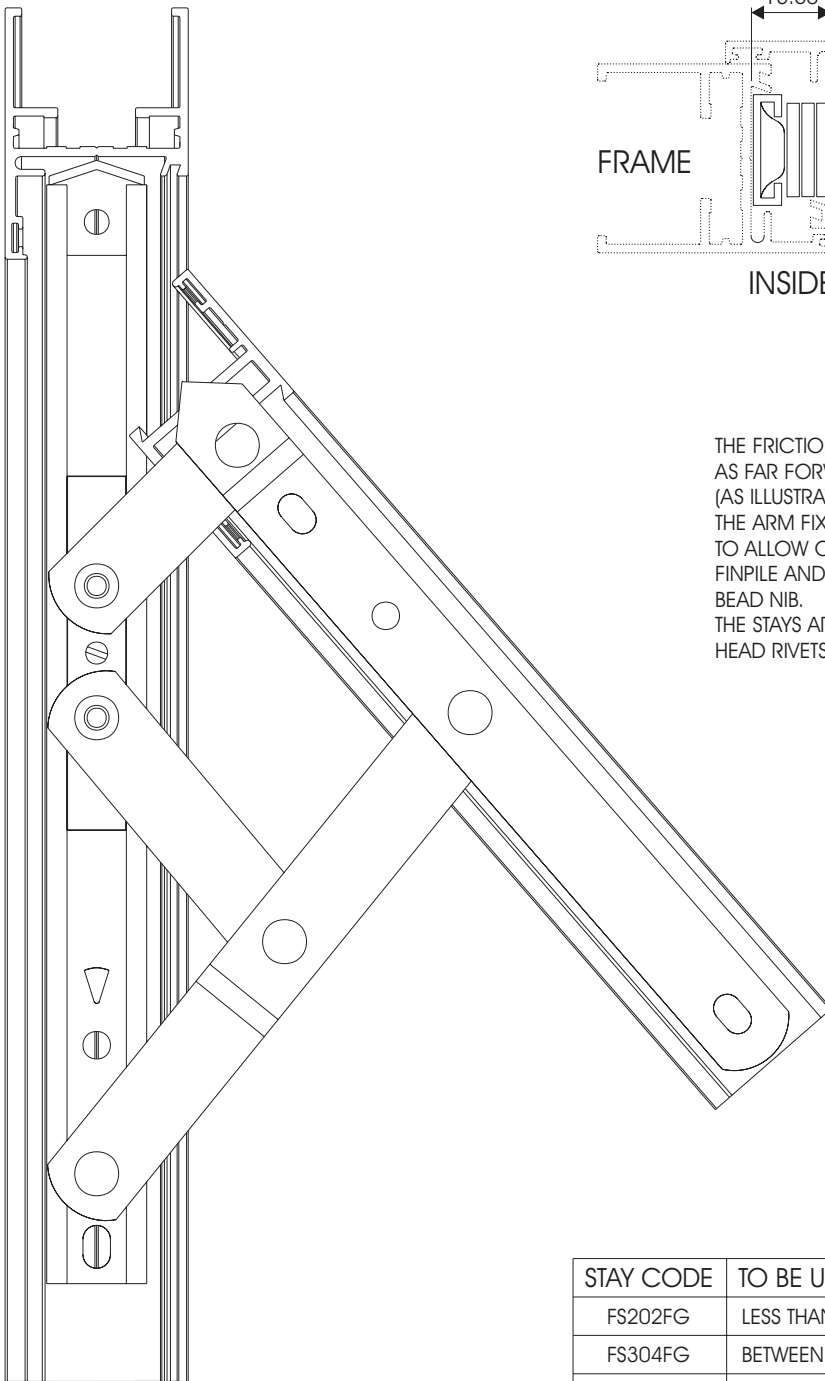

FIGURE 2 - POSITION OF SETTING AND LOCATION BLOCKS

SHEERSASH 34 WINDOW SYSTEM FRICTION STAY ASSEMBLY DETAIL



THE FRICTION STAY SHOULD ALWAYS BE FITTED AS FAR FORWARD IN THE FRAME AS POSSIBLE. (AS ILLUSTRATED)
 THE ARM FIXED TO THE SASH SHOULD BE FITTED TO ALLOW CORRECT COMPRESSION OF THE FINPILE AND PACKED TO CLEAR GLAZING BEAD NIB.
 THE STAYS ARE SECURED WITH 4.8 x 10 DOME HEAD RIVETS.

STAY CODE	TO BE USED FOR SASH SIZE
FS202FG	LESS THAN OR EQUAL TO 300mm
FS304FG	BETWEEN 301mm AND 450mm
FS406FG	BETWEEN 451mm AND 600mm
FS600FG	BETWEEN 601mm AND 900mm

SHEERSASH 34 WINDOW SYSTEM HANDLE ASSEMBLY DETAIL

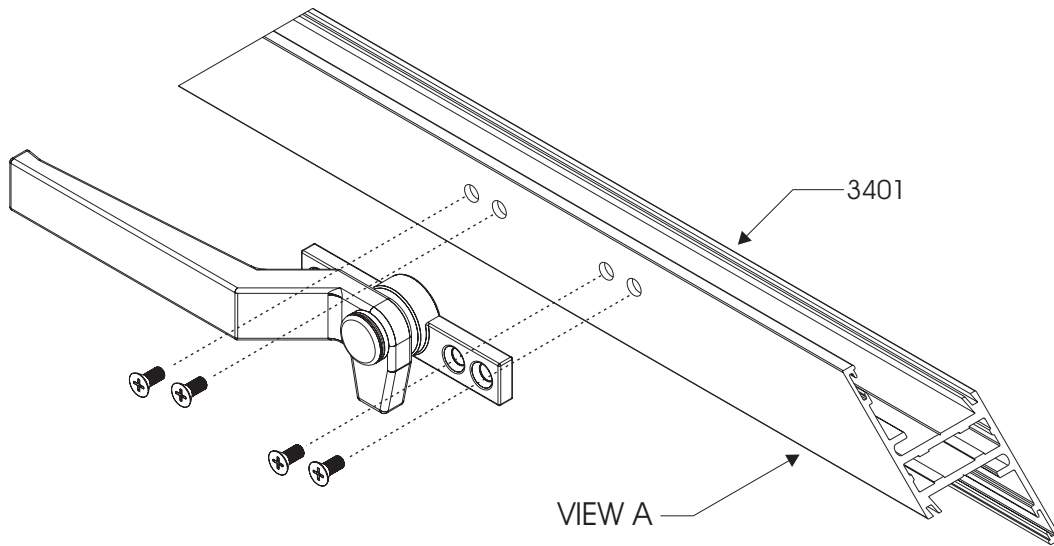

NO 8 x 10 COUNTERSUNK SELF-TAPPING
FLAT END SCREWS

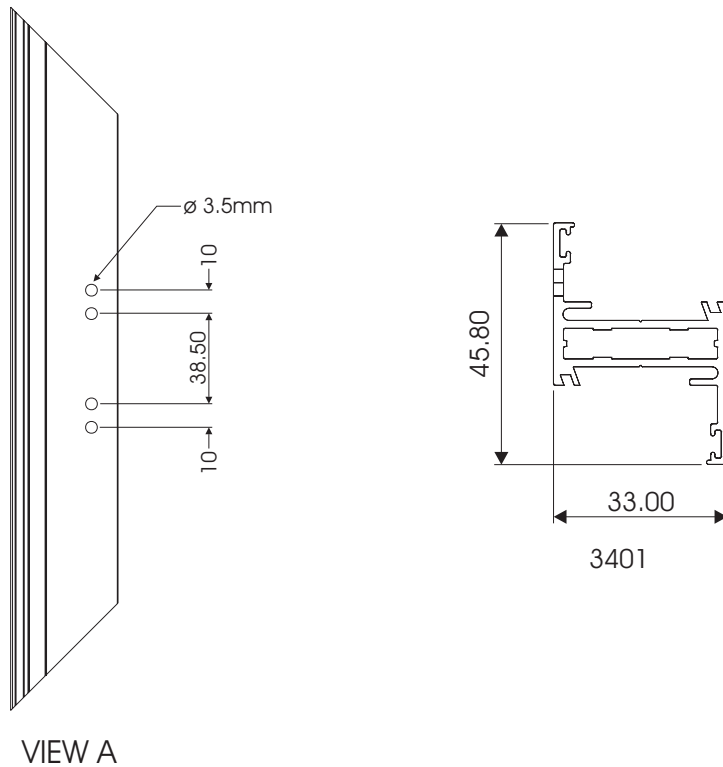

SHEERSASH 34 WINDOW SYSTEM FIXING LUG PREPARATION DETAIL

