

SAMYUNG ENC

AIS-50N USER MANUAL





Industry Canada

Operation is subject to the following two conditions: (1) this device may not cause interference, and (2) this device must accept any interference, including interference that may cause undesired operation of the device.

FCC Statement

Note: This equipment has been tested and found to comply with the limits for a Class B digital device, pursuant to Part 15 of the FCC Rules. These limits are designed to provide reasonable protection against harmful interference in a normal installation. This equipment generates uses and can radiate radio frequency energy and, if not installed and used in accordance with the instructions, may cause harmful interference to radio communications. However, there is no guarantee that interference will not occur in a particular installation. If this equipment does cause harmful interference to radio or television reception, which can be determined by turning the equipment off and on, the user is encouraged to try to correct the interference by one or more of the following measures:

- 1- Reorient or relocate the receiving antenna
- 2- Increase the separation between the equipment and receiver
- 3- Connect the equipment into an output on a circuit different from that to which the receiver is connected
- 4- Consult the dealer or an experienced technician for help
- 5- A shielded cable must be used when connecting a peripheral to the serial ports

Important

It is the owner's sole responsibility to install and use the unit in a manner that will not cause accidents, personal injury or property damage. The user of this product is solely responsible for observing safe boating practices.

Global Positioning System: The Global Positioning System (GPS) is operated by the US government which is solely responsible for its operation, accuracy and maintenance. The GPS system is subject to changes which could affect the accuracy and performance of all GPS equipment anywhere in the world.

Installation: If installation is not correct, the unit can not perform at its designed potential. If in doubt, consult your Samyung ENC dealer. Ensure that any holes made are in a safe position and will not weaken the boat's structure. If in doubt, consult a qualified boat builder.

SAMYUNG ENC DISCLAIMS ALL LIABILITY FOR ANY USE OF THIS PRODUCT IN A WAY THAT MAY CAUSE ACCIDENTS, DAMAGE OR THAT MAY VIOLATE THE LAW.

Governing language: This statement, any instruction manuals, user guides and other information relating to the product (documentation) may be translated to, or has been translated from, another language (translation). In the event of any conflict between any translations of the documentation, the English language version of the documentation will be the official version of the documentation. This manual represents the installation procedures as at the time of printing. Samyung ENC reserves the right to make changes to specifications without notice.

Copyright © 2009 Samyung ENC, Republic of Korea, all rights reserved.

Presentation

Thank you for having purchased a Samyung ENC product. This handbook contains an explanation of how to install, operate and maintain your unit.

SAFETY INSTRUCTIONS



Electronic charts displayed by the chart plotter are believed to be accurate and reliable, but they are not intended to replace official charts which should remain your main reference for all the matters related to the execution of a safe navigation. For this reason we would like to remind you that you are required to carry on board and use the officially published and approved nautical chart.

Please read through this manual before the first operation. If you have any questions, please contact the customer service or your local dealer or distributor. Extensive exposure to heat may result in damage to the chart plotter. Connection to the power source with reversed polarity will damage the chart plotter severely. This damage is not covered by the warranty.

Do not disassemble. The chart plotter contains dangerous transmission, receiving circuits which only experienced technicians must handle. Exposure of the display to UV rays may shorten the life of the liquid crystals used in you plotter. This limitation is due to the current technology of the LCD display.

Avoid overheating which may cause loss of contrast and, in extreme case, a darkening of the screen. Problems which occur from over heating are reversible when temperature decreases.

Screen Cleaning Precautions

Cleaning your chart plotter screen is a very important operation and must be done carefully. The following is the cleaning procedure.

You use a tissue or lens tissue and a cleaning spray containing Isopropanol (a normal spray cleaner sold for PC screens). Fold the tissue or lens tissue into a triangular shape, moisten the tip and use the index finger behind a corner to move the tissue across the surface, in overlapping side to side strokes. If the tissue is too wet, a noticeable wet film will be left in its path and you will need to repeat the process. If too dry, the tissue won't glide easily, and may damage the surface.

If you require technical advice or assistance, contact your nearest Samyung ENC office or visit our website, www.samyungenc.com.

1 Introduction

1-1 Summary	9
1-2 AIS Technology Summary	9
1-3 Specification.....	11
1-4 Packing List.....	12
1-5 Optional Accessories	12

2 Getting Started











2-1 Mounting the Unit.....	13
2-1-1 Bracket Mounting.....	13
2-1-2 Flush Mounting.....	13
2-2 Keys	14
2-3 C-MAP MAX Secure Digital (SD) Card	15
2-4 Manual / Auto Power on and off.....	15
2-5 SRM(Safety Related Message).....	16
2-6 Brightness, night mode and Background	16

3 AIS Function Explanation



3-1 Screen configuration	17
3-2 Screen change.....	18
3-3 Vessel list.....	18
3-4 Own vessel / other vessel information	19
3-5 AIS.....	19
3-5-1 Message.....	20
3-5-2 Initial setup	21







4 General Operation

4-1 Chart Selection	22
4-2 Simulate Mode.....	22
4-3 Data Bar	22
4-4 Compass.....	23
4-5 Multi window displays	24
4-6 The page window	26
 4-7 Chart	28
4-7-1 Chart window	28
4-7-2 Perspective view	28
4-7-3 Latitude and longitude.....	29
4-7-4 Chart scale	29

	4-7-5 Finding a chart symbol.....	29
	4-7-6 S-Map search.....	30
	4-7-7 Chart symbols and information.....	30
	4-7-8 Introduction to navigating.....	30
	4-7-9 Going to a waypoint or to a point on the chart.....	31
	4-7-10 Following a route.....	31
	4-7-11 Goto Key.....	31
	4-7-12 Distance and bearing calculator.....	32
	4-7-13 Projected course.....	32
	4-8 Highway.....	33
	4-9 Gauges.....	33
	4-10 Waypoints.....	34
	4-10-1 Creating a new waypoint.....	34
	4-10-2 Moving a waypoint.....	34
	4-10-3 Editing an existing waypoint.....	34
	4-10-4 Deleting a waypoint.....	35
	4-10-5 Find a waypoint.....	35
	4-10-6 Sort Waypoints.....	35
	4-10-7 Deleting all waypoints.....	35
	4-11 Routes.....	36
	4-11-1 Managing a route from the chart window.....	36
	4-11-2 Managing a route from the route window.....	37
	4-12 Satellites.....	38
	4-12-1 Satellite information.....	38
	4-13 Tides.....	39
	4-14 AIS.....	40
	4-14-1 Viewing AIS Vessels.....	40
	4-14-2 AIS Windows.....	40
	4-15 DSC.....	42
	4-15-1 distress.....	42
	4-15-2 Poll.....	43
	4-16 NAVTEX.....	44
	4-17 Engine Faults.....	44

5 Advance Settings

	5-1 System Configuration Settings.....	45
	5-1-1 Language.....	45
	5-1-2 Chart Selection.....	45
	5-1-3 Beep volume.....	45
	5-1-4 Auto power.....	45
	5-1-5 Features.....	45
	5-1-6 Factory reset.....	45
	5-1-7 About.....	45
	5-2 Chart Settings.....	46
	5-2-1 Rotation.....	46

	5-2-2 Palette.....	46
	5-2-3-1 General(C-MAP).....	46
	5-2-3-2 General(S-MAP).....	47
	5-2-4-1 Land & Sea (C-MAP).....	47
	5-2-4-2 Land & Sea (S-MAP).....	47
	5-2-5 Map datum.....	47
	5-2-6 NMEA datum offset.....	48
	5-2-7 Map shift.....	48
	5-2-8 Restore default.....	48
	5-3 Communication setup.....	49
	5-3-1 NMEA 2000.....	49
	5-3-2 NMEA 0183-Port 1.....	49
	5-3-3 NMEA 0183-Port 2.....	49
	5-4 GPS Settings.....	50
	5-4-1 GPS Source.....	50
	5-4-2 DGPS Source.....	50
	5-4-3 Static Navigation.....	50
	5-4-4 Speed Filter and Course Filter.....	50
	5-4-5 Lat/Lon d.p's.....	50
	5-4-6 Ship speed.....	50
	5-4-7 Magnetic Variation.....	50
	5-5 Track & Log Settings.....	51
	5-5-1 Track.....	51
	5-5-2 Logs.....	51
	5-6 Memory Settings.....	52
	5-6-1 Save.....	52
	5-6-2 Load.....	52
	5-6-3 Delete.....	52
	5-6-4 Format.....	53
	5-6-5 Screen snap shot.....	53
	5-7 AIS Settings.....	53
	5-7-1 Display filter.....	53
	5-7-2 Alarm option.....	54
	5-7-3 Display options.....	54
	5-7-4 Restore default.....	54
	5-8 Alarms.....	55
	5-8-1 Fish.....	55
	5-8-2 Deep.....	55
	5-8-3 Shallow.....	55
	5-8-4 Temperature.....	55
	5-8-5 Temperature rate.....	55
	5-8-6 Low battery.....	55
	5-8-7 Navigation alarms.....	55
	5-8-8 AIS.....	55
	5-8-9 DGPS.....	55
	5-8-10 Restore default.....	55
	5-9 Others.....	56
	5-9-1 Simulate.....	56
	5-9-2 Waypoint.....	56
	5-9-3 GPS.....	56

5-9-4 Units	56
5-9-5 Comms	56
5-9-6 Time.....	56
5-9-7 Restore default	56
5-9-8 Calendar.....	56

6 INSTALLATION

6-1 Options and Accessories	57
6-2 Connections	57
6-3 Power/data cable.....	58
6-4 Alarm	59
6-5 VHF antenna installation.....	60
6-6 GPS antenna	61
6-6-1 GPS antenna of BNC type	61
6-6-2 The antenna using NMEA.....	61
6-7 NMEA 0183	62
6-8 NMEA 2000	63
6-9 Setup and test.....	63

1 Introduction

1-1 Summary

AIS is a spearhead equipment to provide voyage information such as ship's position, course, speed, etc. real time. This is to protect the marine collision of ships, obligations, IMO promotes. AIS induction makes it possible to recognize the existence of other ships & progress status, even if radar cannot recognize ships around. Under the poor field of visions, this can discern ship name, course, speed, which can make safety managements such as ship collision protection, broad area control, search & rescue, etc, more efficiently. AIS is using VHF frequency. In 1997, International Telecommunication Union World Radio communication Conference specified two VHF frequencies (161.975 MHz - 87B channel & 162.025 MHz - 88B channel) for AIS.

AIS-50N has high efficiency AIS Class B. It provides plotter functions, needed in voyage. Some functions can be used with establishment of option devices and sensors only.

AIS-50N can be connected to outer devices, which have NMEA0183 or NMEA 2000. It can display relevant information.
ex.)

- Navtex
- DSC VHF radiotelegraph
- Auto Navigation equipment

1-2 AIS Technology Summary

Communication methods of AIS are simplex, semi-duplex, or duplex operation of TDMA (Time Division Multiple Access). Allowance of occupied bandwidth is within 25kHz. These are classified into A Class & B Class transceivers, equipped on vessels, according to uses.

- ▶ **A Class transceiver** : Mandatory installed in international passenger ships & ocean-going ships over 300ton. Ship positions should be reported on voyage.
- ▶ **B Class transceiver** : Mainly installed in small ships of length under 65 feet.

4 data information, used in AIS are as followings.

- ▶ **Safety Related Message** : This is according to requirement of message, includes voyage information or weather warning.

- ▶ **Static Information** : IMO number, call sign & vessel name, length & width of vessel, vessel type. Renewal of antenna positions (division of vessel prow, stern & left light sides) of GPS is done every 6 minutes or when data are revised, or there is a demand.

- ▶ **Dynamic Information** : Accurate mark of ship position, overall status, Coordinated Universal Time (UTC), course, speed, heading, voyage status, yaw angle & sensor information. These are renewed by interval of following table, according to change of speed & direction.

- ▶ **Voyage Related Information** : Draft, risk cargo, destination & ETA, route plan & boarding persons. Renewal is done every 6 minutes or when data are revised, or there is a demand.

Intervals of Information renewal are shown by table, according to ship status, classified by two Classes of AIS.

Ship status (A Class)	Interval
Under speed 3 knots, in anchorage or moorage	3min.
Over speed 3 knots, in anchorage or moorage	10sec.
Under 14 knots in voyage	10sec.
Under 14 knots in changing courses in voyage	3½sec.
Over 14 knots under 23 knots in voyage	6sec.
Over 14 knots under 23 knots in changing courses in voyage	2sec.
Over 23 knots in voyage	2sec.
Over 23 knots in changing courses in voyage	2sec.

Ship status (B Class)	Interval
Under 2 knots in voyage	3min.
Over 2 knots in voyage	30sec.

General Overall contents, explained above, can be summarized as below table.

Data	A Class	B Class
Static Information of radio station	▼	▼
- MMSI	▼	▼
- vessel name	▼	▼
- vessel type	▼	▼
- call sign	▼	▼
- IMO number	▼	▼
- antenna position	▼	▼
Voyage Related Information	▼	
- draft	▼	
- boarding persons	▼	
- risk cargo	▼	
- destination & ETA	▼	
Dynamic Information of radio station	▼	▼
- Universal Time Coordinated. (UTC)	▼	▼
- ship position	▼	▼
- course(COG)	▼	▼
- speed(SOG)	▼	▼
- heading	▼	▼
- turn rate	▼	▼
- voyage status	▼	
- ship speed	▼	▼
- ship status	▼	
Safety Related Message	▼	
- alarm	▼	
- safety	▼	▼

1-3 Specification

[AIS-50N]

GENERAL	
Category	Detail
Size	164 mm(H) x 183 mm(W) x 92.5 mm(D)
Display	5.6" diagonal, TFT color, 480 x 640 pixels.
Supply voltage	10 to 34 V DC
Supply current	13.8 V 24 V 1A - AIS receiving by mode 0.5A - AIS receiving by mode 2A - AIS transmitting mode 0.9A - AIS transmitting mode
External beeper or light output	Switched to ground to sound alarm, 30V DC, 200 mA maximum
Operating temperature	-10° to 50°C
ALARMS	
User set up: Arrival, Anchor, deviation, risk, low voltage, AIS risk vessel, AIS approaching	
GPS NAVIGATION	
Chart card	C-MAP™ SD Card (NT-MAX, NT+ or NT)
User card	SD Card
Waypoints	Up to 10,000, with default or user defined alphanumeric names up to eight characters.
Routes	100 Routes, with up to 100 points each
Tracks	By time or distance, 10 track of 15,000 points
Chart datums	216 Chart datums, One user-defined map shift.
Chart scale	0.2 to 500 nm for chart (chart dependent) down to 0.005 nm in plotter mode.
COMMUNICATIONS	
NMEA	NMEA 0183 4800, 9600, 38400 baud, NMEA 2000
NMEA 0183(1) Inputs from compatible instruments	DBK, DBS, DBT, DPT, GGA, GLL, GNS, GGA, GSV, HDG, HDT, MDA, MTA, MTW, MWD, MWV, RMC, RPM, VHW, VTG, VWT, ZDA
NMEA 0183(1) Outputs, for compatible instruments	APA, APB, BWR, GGA, GLL, GSA, GSV, RMB, RMC, VTG, XTE, DBT, DPT, MTW, VHW, XDR
NMEA 0183(2) Inputs from compatible instruments	GGA, GLL, HDT, RMC, GSV, SSD, VSD
NMEA 0183(2) Outputs, for compatible instruments	GGA, GLL, HDT, RMC, GSV, VDM, VDO, ALR, TXT, ACS, ACA, ACK, GSB
NMEA 2000 Inputs from compatible instruments	System date and time(PGN126992), Vessel Heading(PGN127250), Engine parameters/Rapid Update(PGN127488), Engine parameters/Dynamic(PGN127489), Trip parameters/Engine(PGN127497), Engine parameters/Static(PGN127498), Fluid level(PGN127505), Water Speed(PGN128259), Water depth(PGN128267), Position/Rapid Update(PGN129025), COG & SOG/Rapid Update(PGN129026), GNSS Position Data(PGN129029), GNSS DOPs(PGN129539), GNSS Sats in View(PGN129540), Wind Data(PGN130306), Environmental Parameter-Water temp(PGN130310), Environmental Parameter(PGN130311)
NMEA 2000 Outputs, for compatible instruments	Water Speed(128259), Water depth(128267), XTE(129283), NAV. data(129284), NAV. data(129285), COG & SOG(129026), GNSS position(129029), Water temp.(130310)
AIS	
VHF Transceiver Transmitter x 1 Receiver x 2	Frequency: 156.025 to 162.025 MHz in 25 kHz steps Receiver 1. default CH is 87A, AIS (161.975 MHz) Receiver 2. default CH is 88B, AIS (162.025 MHz)
Channel Bandwidth	25 kHz
Communication	Simplex & semi-duplex operation
Antenna Impedance	50Ω(TNC)
Frequency stability	±10 PPM(-20 °C to +60 °C)

1-4 Packing List

Item List	Part number
Display	AIS-50N-E
Bracket	N560-DB
Display Cover	N560-CB
Protection Cover	N560-CC
Power Cable	LTW-2000-8
Bracket mounting screw	N560-BP
Flush mount Kit (Including screw)	N560-TK
Cable tie	N560-CK
User's Manual(Eng)	AIS-50N-ME

1-5 Optional Accessories

Model	Part number	Item List
GPS Antenna + GPS Antenna Installation Material	SAN-60-10M	GPS antenna + BNC Plug
		GPS antenna support
		GPS antenna cable(10m)
GPS Antenna Stand type Support	57745	GPS Antenna Stand type Support
VHF Antenna + VHF Antenna Installation Material	SAN-150	VHF antenna + TNC Plug
		VHF antenna support
		VHF antenna cable(15m)

2 Getting Started

2-1 Mounting the Unit

The chart plotter is supplied with bracket and flush mounting kit. You can choose a method of installation according to your preference.

2-1-1 Bracket Mounting

Select the position, considering weight of equipment, conveniences, etc before installing.

Display installing:

- 1 Gripping display, find both connecting joints between display & installer.
- 2 Smoothly push in display into the both connecting groove of installer.
- 3 Turn on both knobs.

Display separation

- 1 Switch off the device.
- 2 Turn off both knobs & separate display & installer.



2-1-2 Flush Mounting

- 1 Find a location for flush mounting.
- 2 Drill a hole in the area of the cutout area for the blade of jig saw.
- 3 insert and cut out the area on the panel using the jig saw
- 4 Drill four holes for mounting studs.
- 5 Install the mounting studs on the chart plotter and insert them into the mounting hole.
- 6 Attach the chart plotter to the mounting location by attaching the supplied hardware to the mounting studs.

Note

Before drilling work, check if there is enough space for device installation.



2-2 Keys

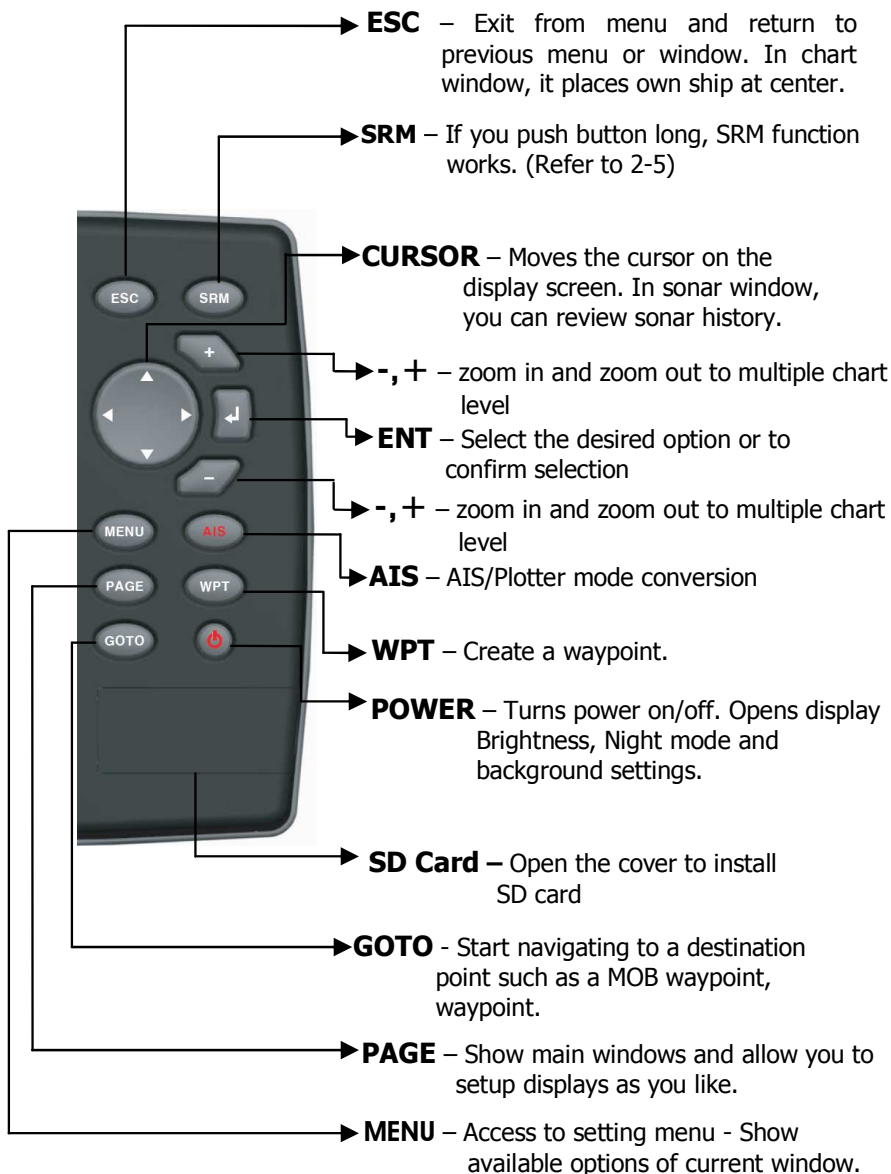

2-3 C-MAP MAX Secure Digital (SD) Card

This section provides instructions for inserting and removing C-MAP MAX SD card procedure.

Inserting the SD Card

- 1 Hold the SD card so that you can see the C-Map label.
- 2 Open the door, gently push the SD card into the slot; push the SD card in as far as you hear click sound, then close door.



Removing the SD Card

- 1 Turn off the unit.
- 2 Open the door and push in on the SD card until it is released.
- 3 Close the door.

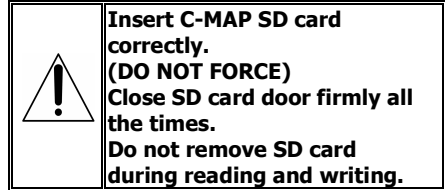

2-4 Manual / Auto Power on and off

Manual power on

Press and hold until the display shows the start up page. When the Warning screen appears, press to accept.

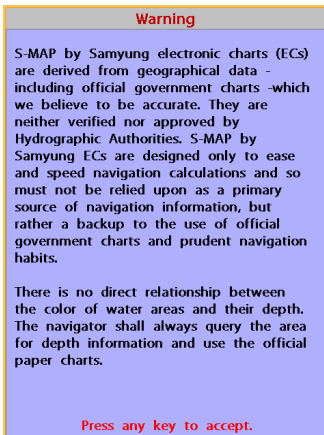

Manual power off

Press and hold for 5 seconds. A counter timer appears on the screen, if you release the button before the countdown timer reaches zero, the chart plotter will remain On.

Auto power

If the unit is wired for auto then:

- The unit turns on automatically when you turn on the boat's ignition.
- You can not turn off the unit if the ignition is turned on.
- If Auto power off is set, the unit turns off automatically when you turn off the boat's ignition.
- If Auto power off is set, the unit will not be turned off even though the boat's ignition is turned off. To turn off, you need to turn off the unit manually.

2-5 SRM(Safety Related Message)

Users can set up 15 letters. If you push SRM button, set up message is transmitted.

If you push SRM button long, counter is displayed. In 3 seconds (3->2->1), setup message is transmitted.

SRM function of AIS-50N is made to meet 62287-1 Message 14 standard of IEC(International. Electrotechnical Commission) Users can set up SRM, which they want, referring to 3-5-1.





SRM does not work, when equipment does not receive GPS signals.

2-6 Brightness, night mode and Background

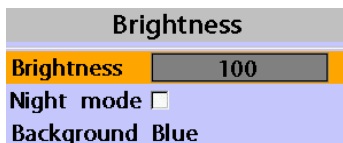
You can change the screen setting for the display. To change settings, shortly press .





Brightness

To change the brightness, select **Brightness**, and press  to dim or  to brighten. Press  to return to the previous screen.

Night mode

The AIS-50N has preprogrammed settings allowing you to customize the look of the **Chart** window. The default is daytime view. Select **Night mood** depending on what mode the display is in at the time of selection.

To change mode:

- 1 Highlight **Night mode**.
- 2 Press  or .



Tip: The screen will be difficult to read if the chart plotter is in **night mood** when the sun is too bright

Background

You can Change the background color if necessary. This selection is a personal preference. Select the option that gives you the clearest viewing in your weather conditions and viewing angle.

3 AIS Function Explanation

3-1 Screen configuration

Opening screen is the vessel list of AIS-50N, which shows the distances & directions information from own vessel, utilizing received information from other vessels.

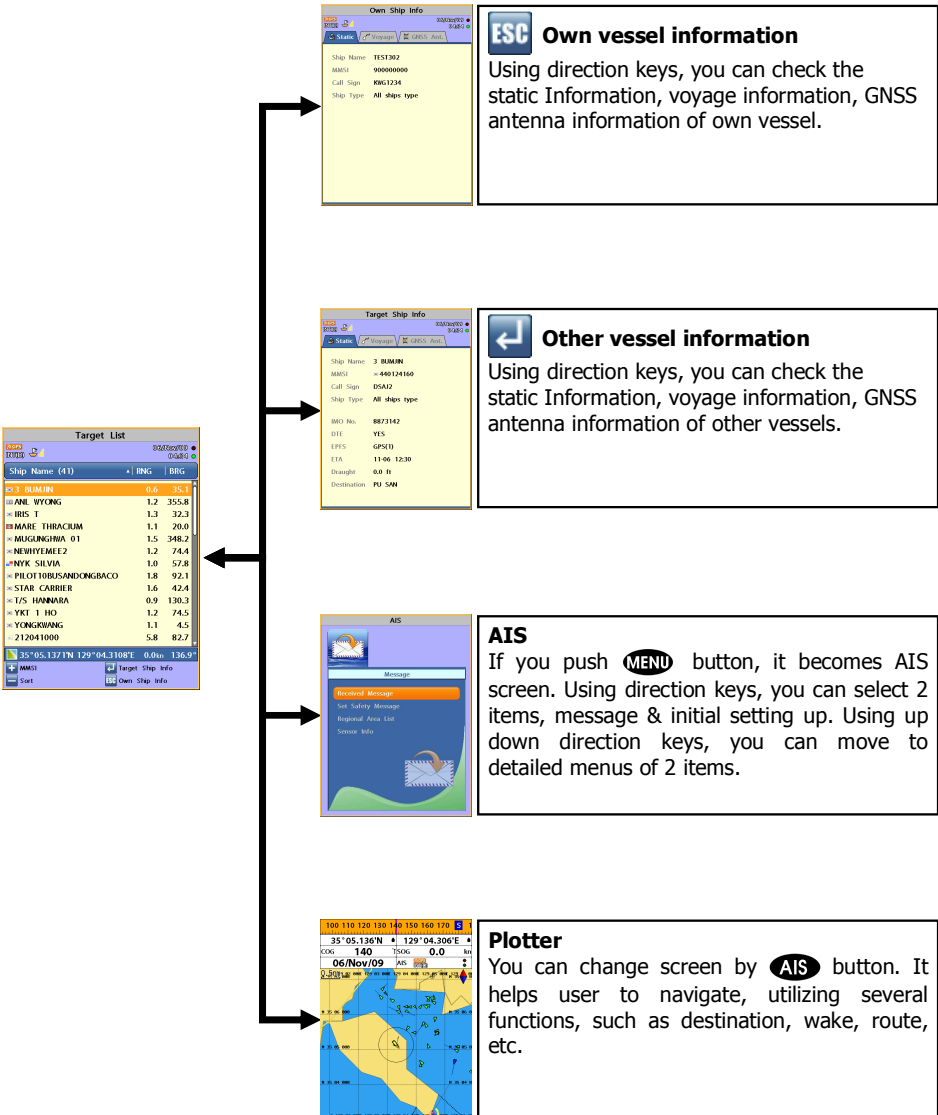

3-2 Screen change

By **AIS** button you can change screen(AIS/Plotter).

AIS

AIS is the system to discern vessel position & information. As the main function of AIS-50N, this shows on screen the distances & directions information from own vessel, utilizing received information from other vessels.

Target List			
Ship Name (41)	RNG	BRG	
BUMJIN	0.6	35.1	
ANL WYONG	1.2	355.8	
IRIS T	1.3	32.3	
MARE THRACIUM	1.1	20.0	
MUGUNGHWA 01	1.5	348.2	
NEWHYEMEE2	1.2	74.4	
NYK SILVIA	1.0	57.8	
PILOT10BUSANDONGBACO	1.8	92.1	
STAR CARRIER	1.6	42.4	
T/S HANNARA	0.9	130.3	
YKT 1 HO	1.2	74.5	
YONGKWANG	1.1	4.5	
212041000	5.8	82.7	

35°05.1371'N 129°04.3108'E 0.0kn 136.9°

MMSI Target Ship Info
Sort Own Ship Info

Plotter

As the additional function of AIS-50N, this helps user to check easily, displaying other ship's movements on marine chart.

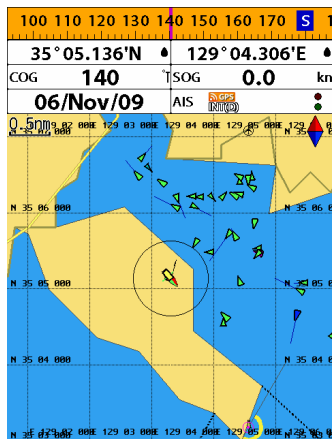

3-3 Vessel list

Opening screen is the vessel list of AIS-50N, which shows the distances & directions information from own vessel, utilizing received information from other vessels.

Target List			
Ship Name (41)	RNG	BRG	
BUMJIN	0.6	35.1	
ANL WYONG	1.2	355.8	
IRIS T	1.3	32.3	
MARE THRACIUM	1.1	20.0	
MUGUNGHWA 01	1.5	348.2	
NEWHYEMEE2	1.2	74.4	
NYK SILVIA	1.0	57.8	
PILOT10BUSANDONGBACO	1.8	92.1	
STAR CARRIER	1.6	42.4	
T/S HANNARA	0.9	130.3	
YKT 1 HO	1.2	74.5	
YONGKWANG	1.1	4.5	
212041000	5.8	82.7	

35°05.1371'N 129°04.3108'E 0.0kn 136.9°

MMSI Target Ship Info
Sort Own Ship Info

- : Pushing **+** button, you can check vessel name or MMSI information.
- : Pushing **-** button, you can select the lineup.(vessel name / distance / direction)
- : Selecting the vessel, which user will check, using up down direction keys, then push .
- : Pushing **ESC** button, you can check own vessel information.

3-4 Own vessel / other vessel information

Using own vessel / other vessel information, user can check the static Information, voyage information, GNSS antenna information of own vessel or other vessels easily.

Own vessel information

- 1 Check own vessel information, pushing **ESC** button in vessel list screen
- 2 Return to vessel list screen, pushing **ESC** button in own vessel information screen.

Other vessel information

- 1 Select the other vessel, which user will check, using up down direction keys in vessel list screen.
- 2 Pushing **↓**, check other vessel information.
- 3 Using left right direction keys, select one among 3 items(static, voyage, GNSS antenna), which user wants to check.
- 4 After checking information, return to vessel list screen, pushing **ESC** in other vessel information screen

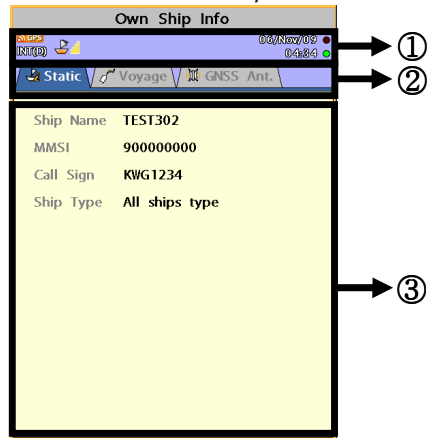

- ① You can check GPS (DGPS) connecting status, VHF reception, date & time information, AIS transmitting (red flickering), receiving (green flickering) status information.
- ② You can select static, voyage, GNSS antenna items, using left right direction keys.
- ③ Information window shows the detailed information of the selected item among 3 items.

3-5 AIS

This shows 2 items, voyage related message(necessary in AIS) & initial information setting up on screen. Pushing **MENU** in vessel list screen, you can move to AIS screen.

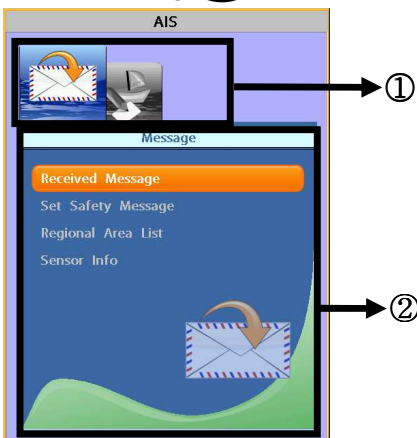

- ① Using left right direction keys, you can select 2(message, initial setting up) items.



: message



: initial setting up

- ② This shows the detailed items of the selected item between 2 items. You can move, using up down direction keys.

3-5-1 Message

Receiving message

You can check Safety Related Message, Voyage Related Message, which AIS base station or other vessels transmit.

Receiving message is checked as follows.

- 1 Selecting receiving message item, push
- 2 Selecting the message, use wants to check, push

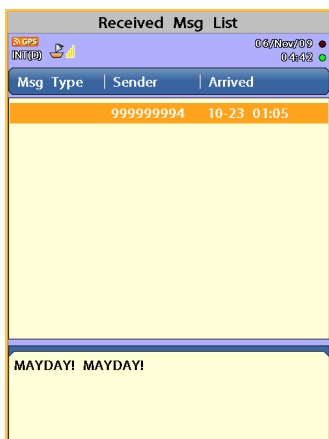

Safety Related Message setting up

Users can set up messages to meet 62287-1 Message 14 standard of IEC. (International. Electro technical Commission)
Initial value: "MAYDAY! MAYDAY!"

Setting up SRM is as follows.

- 1 Selecting SRM setting up item, push
- 2 Push in message input window.
- 3 After setting up messages, using direction keys, push
- 4 After selecting saving items, using up down direction keys, push



Region area list

Among Voyage Related Messages, AIS base station transmit, you can check the information about region area setting up. If own vessel is within the region area, which AIS base station sets up, communication should be done with frequency band, base station set up.

Region area list is checked as follows.

- 1 After selecting region area list item, push
- 2 After selecting area item, which user will check, push

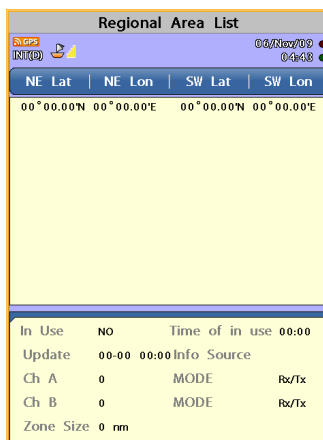

Sensor information

You can check the status of sensor, Input to AIS in voyage.

- ▶ GNSS : Check GPS receiving status
- ▶ speed : Check if vessel moving speed data are input
- ▶ course : Check if vessel moving course data are input
- ▶ head direction : Check if vessel head direction data are input

Sensor information are checked as follows.

- 1 After selecting sensor information item, push
- 2 Check the status of sensor.

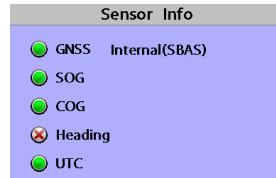

3-5-2 Initial setup

Static information setup

- ▶ MMSI : As maritime identification number, this is assigned for vessel identification. (9digits-number(0~9))
- ▶ vessel name : marked on vessel
- ▶ call sign : To identify vessel.(7digits-capital letter(A~Z), number(0~9), symbol)
- ▶ vessel type

Static information setup is done as follows.

- 1 After selecting static information item, push .
- 2 Using up down direction keys, select the item to set up among 4 items.
- 3 Pushing , input value, using direction keys.
- 4 After selecting saving, using up down direction keys, push .

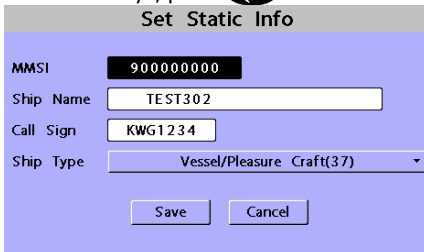

Antenna position setup

You can set up the position of GPS inner/outer antenna of own vessel.

- ▶ A+B = 0~511m
- ▶ C+D = 0~63m

Region area setup is done as follows.

- 1 After selecting antenna position setup item, push .
- 2 Select the item to set up, using up down direction keys.
- 3 Pushing , input value, using direction keys.
- 4 After selecting saving, using up down direction keys, push .

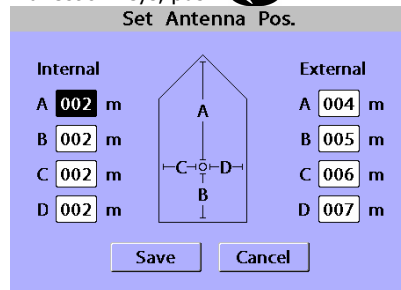

Static information can be once set up at the beginning. User cannot change it voluntarily. For detailed contents, refer to distributors.

4 General Operation

4-1 Chart Selection

A user can select a map between C-MAP and S-MAP.

Chart Selection

- 1 Press and hold **MENU**.
- 2 Select the system setting icon.
- 3 Select Chart then a chart you prefer.

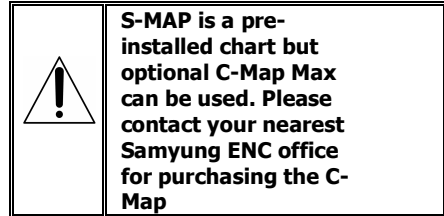

4-2 Simulate Mode

Simulate Mode is great for practicing the actual use of a product when the satellites signals and internal alarms are not available. In the simulate mode, the unit turns the GPS receiver off and ignores data from all optional devices.

Two simulate modes are available as below.

- **Normal:** Allows a user to practicing the actual use of a product without satellites connection.
- **Demo:** boat travel alone given route at given speed and show different function of the unit.

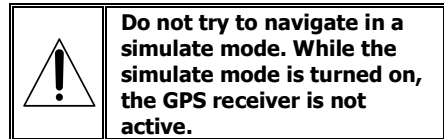

4-3 Data Bar

Data bar displays useful navigation information at the top of the display.

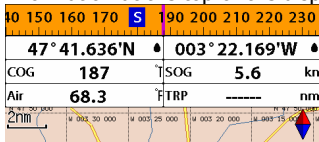

Displaying Data bar

- 1 Press **MENU** and select **Data bar**.
- 2 Select **Data bar**.

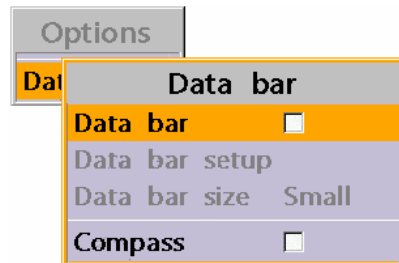

Setting the data displayed in data bar

- 1 Press **MENU** and select **Data bar**.
- 2 Select **Data bar** then **Data bar setup**.
- 3 Move the cursor key to highlight the data field you want to change then press **↓**.
- 4 Select **Data type**.
- 5 Select a desired data you want to display in the field then press **↓**.
- 6 Repeat above steps if necessary.

Selecting the Data bar size

- 1 Press **MENU** and select **Data bar**.
- 2 Select **Data bar** then **Data bar size**.
- 3 Select the desired size of data bar.

[Large]

47° 41.415'N • 003° 22.238'W		
COG	194	T SOG 4.1 kn
Air	50.2	F TRP ----- nm

[Small]

47° 41.238'N • 003° 22.289'W		
COG	187	T SOG 5.9 kn
Air	52.6	F TRP ----- nm

Tip: If you select None for all data fields, the data bar will disappear to save space for the chart.

Tip: Even though you setup a data bar for specific window, the data bar is not apply to all other window.

4-4 Compass

The chart plotter computes compass direction from the constellation of GPS satellites. For the GPS chart plotter to compute direction the vessel must be moving through the water.



For easy reading and recognition, there is a compass needle at top right side.

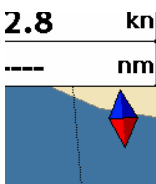

When the compass is displayed, COG is always displayed in data field.
Also when you are navigating to a point, COG and BRG is always displayed in data bar.

Tip

COG(Course Over Ground) – The course you vessel is heading.

BRG(Bearing) – The direction from your current position to a destination point.

To turn the compass off or on:

- 1 Press **MENU** and select **Data bar**.
- 2 Select **Compass**.

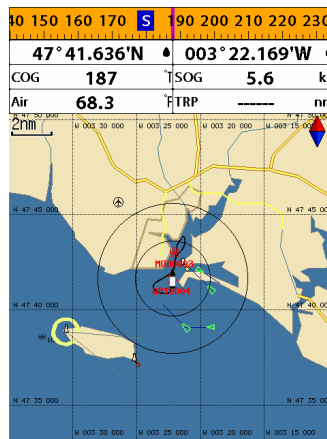

4-5 Multi window displays

The Chart plotter can display up to four windows at the same time.

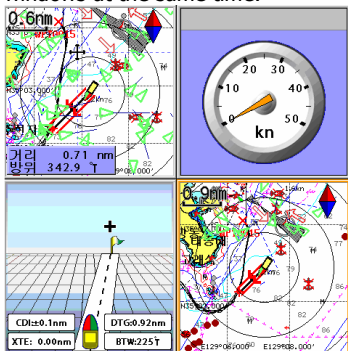

Adding a window

- 1 Press **PAGE** and select **Add** icon.
- 2 Select an icon you want to add.
- 3 Repeat above steps if necessary.



Changing window size

- 1 Press **PAGE** and select **Split** icon on bottom.
- 2 Press **▲** or **▼** to change the height of the windows if there is only two windows. If the unit is displaying more than three windows, press **▲**, **▼**, **◀** or **▶** to change the height of the windows.

Deleting a window

- 1 Press and hold **PAGE** to select a window you want to delete.
- 2 Press **PAGE** and select **Remove** icon to remove.

Replacing two windows on the display

- 1 Press and hold **PAGE** to active desired window you want to replace.
- 2 Press **PAGE**, select **Replace** icon.
- 3 Select icon you want to display then press **↓**.

The active window

To distinguish an active window among windows, an orange border indicates the active window. To change the active window to the next window, press and hold **PAGE**.

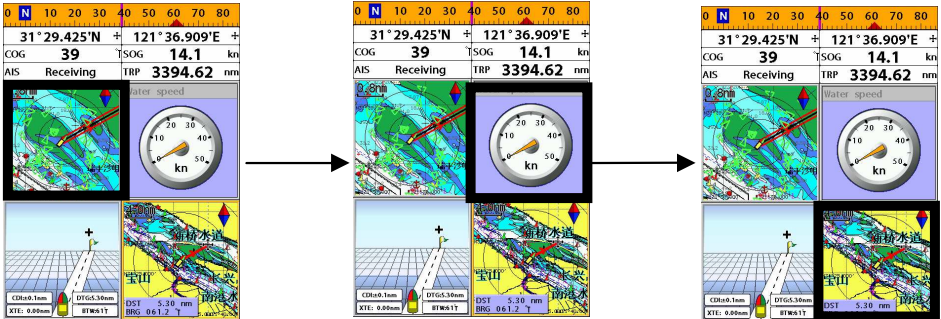

Favorite displays

The most commonly used windows are called favorite displays and up to six favorite windows can be saved. Also each favorite display can have data bar and compass.



Displaying a favorite display

- 1 Press **PAGE** twice.
- 2 when above window pops up select a desire display you want.

Adding a favorite display

- 1 Organize a window as you want.
- 2 Press **PAGE** to show the main window.
- 3 Select **Save** icon at the bottom
- 4 Select an icon where you want to add your favorite display. If you add the new favorite display on existing favorite display new display will overwrite the old display.

4-6 The page window

Press **PAGE** to show the page window and select a function icon you want to display.



 **Note**

- 1 Some function icons require optional units and connected sensors.
- 2 If you press **PAGE** one more time in the main window, favorite window is displayed.



Chart



Highway

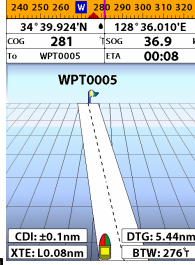

Data

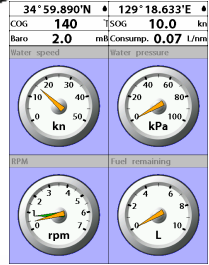

Waypoints

NAME	Latitude	Longitude	DIST	RST	Drp	Disp
MOR0008	47° 42.970'N	003° 21.908'W	0.0	No		
MOR0009	47° 43.699'N	1.8	No			
MOR0010	47° 43.242'N	1.3	No			
MOR0012	47° 43.699'N	1.8	No			
WPT0002	47° 41.852'N	0.5	No			
WPT0003	47° 41.072'N	1.0	No			
WPT0004	47° 41.315'N	1.7	No			
WPT0005	47° 42.899'N	1.7	No			
WPT0006	47° 41.051'N	0.9	Yes			
WPT0007	47° 41.051'N	1.823	No			



Routes

Name	Start	End	Legs	DIST	Drp
ROUTE01	WPT0001	WPT0003	2	6.0	
ROUTE02	WPT0003	WPT0006	3	16.0	
ROUTE03	WPT0001	WPT0003	1	0.2	
ROUTE04	WPT0003	WPT0006	1	11.0	



Satellite

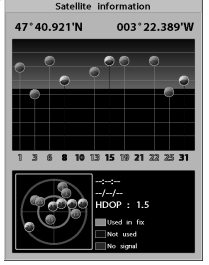

Tides

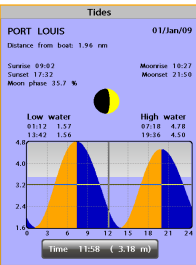

AIS

DSTime	SOG	BRG	MMSI	NAME
04.49	5.6	133333333		
0.76	1.2	211111111		PLASTIMO-C
1.53	12.3	466666666		PLASTIMO-A
1.69	7.8	444444444		PLASTIMO-D
1.94	3.4	252222222		PLASTIMO-B
2.18	15.6	188888888		LORENTE-B
2.65	17.8	169999999		LORENTE-E
2.89	9.0	355555555		LORENTE-A
3.25	13.4	137777777		



DSC

Date Time	Latitude	Longitude	MMSI	NAME
01/01/2009	36° 24.125'N	111.111111111		
12:42	129° 54.587'			



Navtex

Time	MmsgD	Freq
10:51 24/Jan/09	IE03	5180Hz
12:02 24/Jan/09	AC05	5180Hz
18:20 24/Jan/09	IE03	5180Hz

ISSUED ON SATURDAY 24 JANUARY 2009

INSHORE WATERS FORECAST TO 12 MILES OFFSHORE FROM 1700 UTC TO 0300 UTC

NORTH FORELAND TO SELBY HILL

12 HOURS FORECAST:

SHOWERY WINDS, STRONGEST IN NORTH.



Engine Faults

Engine	Status
Port	Over temperature
Port	Low fuel pressure
Port	Charge indicator
Port	Probat indicator
Starboard	Low oil pressure
Starboard	Low fuel pressure

4-7 Chart

The **Chart** window mainly shows all relevant navigation data available on your preloaded maps, including buoys, lights, cables, depth soundings, marinas, and tide station in an overhead view.

4-7-1 Chart window

To go to the **Chart** window:

- Press **PAGE** and select **Chart** icon by pressing **↓**.

A typical Chart window shows:

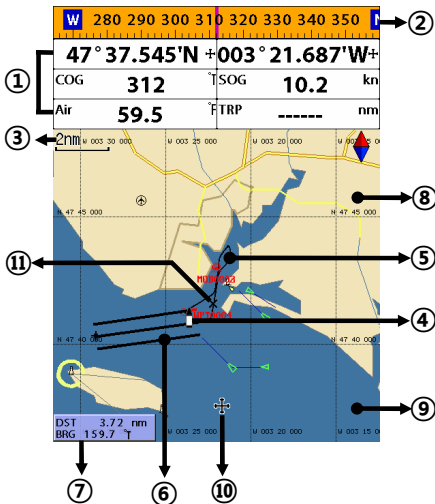

- ① Data bar. To turn the data off or on or to change what data is displayed
- ② Compass
- ③ Chart scale
- ④ Boat position
- ⑤ Boat track
- ⑥ Boat course and CDI lines
- ⑦ Distance and bearing of cursor from boat
- ⑧ Land
- ⑨ Sea
- ⑩ The cursor
- ⑪ A typical waypoint

The built-in world chart does not show enough detail for navigation. When you use the Chart Plotter to navigate, always use a chart card which covers the region.(C-MAP)

4-7-2 Perspective view

If C-Map is selected for the chart, chart data may be projected in perspective mode during navigation. This function allows setting the panoramic view of the chart. As the upper side of the map is more compressed than the lower side, a wider map area is visible.

The perspective view allows showing more chart information immediately ahead and around the cursor.

To activate this function follow the procedure:

- 1 Press **MENU**.
- 2 Select **Perspective**.

S-MAP does not support the Perspective View. (See 4-1 for chart selection)

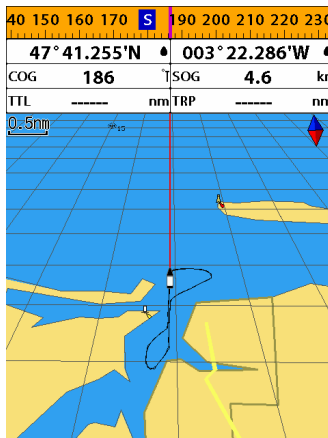

4-7-3 Latitude and longitude

Latitude and longitude coordinates define a position on earth and can be displayed in data bar.

In the data bar, own ship position is shown as below:

- 47° 43.000' N or S Latitude
- 003° 21.656' E or W Longitude

47° 43.000' N	●	003° 21.656' W	●
---------------	---	----------------	---

However, if you move the cursor, then the latitude and longitude in the data bar is the cursor's position as below.

- + 47° 43.325 N or S Latitude
- + 003° 29.607 E or W Longitude

47° 43.325' N	+	003° 20.607' W	+
---------------	---	----------------	---

Info

Latitude: Angular distance North or South of the equator measured by lines encircling the earth parallel to the equator in degrees from 0° to 90°.

Longitude: angular distance North or South of the equator measured by lines encircling the earth parallel to the equator in degrees from 0° to 90°.

	When reading the boat position, make sure the position is not the cursor position.
--	---

4-7-4 Chart scale

The chart scale change by pressing **+** to show more detail information of chart and by **-** to show wider view of the chart.

When you press **+** or **-**, the scale of chart is display in the chart on top left corner.

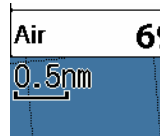

4-7-5 Finding a chart symbol

This function is only available when C-MAP SD card is inserted and C-map is selected.

To find a port by name

- 1 Press **MENU**.
- 2 Select **Find** then **Port by name**.
- 3 Press **▲** or **▼** to select a letter then press **▶** for next letter.
- 4 Once you enter the name of port, press **↓**.
- 5 After searching process, select a nearest port in the list then the cursor will place on the port you selected on the chart window.
- 6 Repeat 2-3 steps of D section to display the information.

To find port & service

- 1 Press **MENU**.
- 2 Select **Find** then **Port & service**.
- 3 Select a service you want to find.
- 4 After searching process, select a nearest service area in the list then the cursor will place on the service area you selected on the chart window.

	S-MAP does not support this function. (See 4-1 for chart selection)
--	--



4-7-6 S-Map search

This function is available when C-MAP SD card is inserted and C-map is selected.

To find port & service

- 1 Press **MENU**.
- 2 Select **Find** then **Port**.
- 3 Press **▲** or **▼** to select a port then **↓**.
- 4 After searching process, select a nearest port in the list then the cursor will place on the port you selected on the chart window.

	C-Map Chart does not support this function. (See 4-1 for chart selection)
--	---

4-7-7 Chart symbols and information

This function is only available when C-MAP SD card is inserted and C-map is selected.

Using C-Map Max card allows you to show different kind of symbols and their information on chart plotter display. On some objects such as a port, you can see a picture of landscape layout.

	S-MAP does not support this function. (See 4-1 for chart selection)
--	---

To display information

- 1 Move cursor on an icon to display its name.
- 2 Press **MENU** and select **Chart info**.
- 3 Move cursor key to highlight an item and press **↓**.
- 4 Information related to the item appears at the bottom window.

[Chart info]

[Chart symbol Data Box]

0 330 340 350	N	10 20 30 40 50
47° 42.970'N		003° 21.908'W
COG	7	T-SOG 8.2 kn
TTL	----- nm TRP ----- nm	

CATEGORY OF POINT OF INTEREST: HOTEL/MOTEL	
NAME: HOTEL LES PECHEURS	
CATEGORY OF POINT OF INTEREST: POST OFFICE	
NAME: LA POSTE DU QUAI DES INDES	
FAST1 DATABASE: 452	
NAME: LAZARE CARNOT, RUE	
DST	1.67 m
BRG	008.0

4-7-8 Introduction to navigating

Use the navigation chart to plan your course, view map information, and as a navigational aid. This unit has two ways of navigating, going straight to a waypoint or following a route (a group of waypoints).

4-7-9 Going to a waypoint or to a point on the chart

A waypoint is a particular location on a voyage whether it is a starting, intermediate or destination point. A waypoint is the simplest piece of information your equipment requires to get you to a destination. In the shortest distance possible. This unit can save up to 10,000 waypoints.

Goto Cursor Option

- 1 Press **PAGE** and select the **Chart** window.
- 2 Move the cursor to the destination point.
- 3 Press **MENU** and select **Goto cursor** to start navigating.

Goto WPT Option

- 1 Press **PAGE** and select the **Chart** window
- 2 Move the cursor to place cursor on a waypoint.
- 3 Press **MENU** and select **Goto WPT** to start navigating.

Find Option

- 1 Press **PAGE** and select the **Chart** icon.
- 2 In the **Chart** window, press **MENU** and select **Find** then **Waypoints**.
- 3 select a waypoint to start navigation.

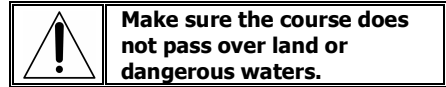

Cancelling navigating

- 1 Press **PAGE** and select the **Chart** icon.
- 2 Press **MENU** and select **Cancel Goto**.

4-7-10 Following a route

Often a trip from one place to another involves several course changes, requiring a series of route points (waypoints) which you navigate to, one after another. The sequence of waypoints leading to the ultimate destination is called a route. You can save up to 100 routes and a route may consist of 100 waypoints.

Start Route Option

- 1 Press **PAGE** and select the chart window.
- 2 Press **MENU** and select **Start Route**.
- 3 Move cursor keys to select a route to start navigating.
- 4 Select **Forward** or **Reverse** to decide which direction you want to navigate.

Route Window Option

- 1 Press **PAGE** and select the routes window
- 2 In the route window, mover the cursor to highlight a route you want to start navigating to.
- 3 Press **MENU** and select **start**
- 4 Select **Forward** or **Reverse** to decide which direction you want to navigate.

Create Route Option

- 1 Press **PAGE** and select the chart window.
- 2 Select **New route**.
- 3 Name a route name.
- 4 Move cursor keys to select a waypoint. (Repeat this step as much as you need)
- 5 Press **MENU** and select **Add**.
- 6 Press **ESC**.
- 7 Repeat 2-4 steps of Route window option.

Skipping a waypoint

- 1 Press **PAGE** and select the chart window.
- 2 Press **MENU** and select **Skip**.
- 3 Repeat above step if necessary.

Cancelling a route

- 1 Press **PAGE** and select the chart window.
- 2 Press **MENU** and select **Cancel route**.

4-7-11 Goto Key

This key is very useful when you desire to start navigating to a destination point. When the key is pressed, it starts navigating to the point of the cursor or Route.

Going to a point

- 1 Move the cursor to an open position.
- 2 Press **GOTO**.

4-7-12 Distance and bearing calculator

The unit can show the bearing and the length of leg and the total distance of legs.

Setting Legs

- 1 In the chart window, press **MENU** and select **Distance**. Information is displayed on window showing bearing/leg distance/total distance at bottom pop up at the bottom left side
- 2 Move the cursor to the start point which is start point of first leg and press **↓**.
- 3 Move the cursor to a point which is the end of first leg.
- 4 Repeat 2-3 steps for more legs.
- 5 Press **ESC** to exit.

Deleting the last leg

- 1 Press **MENU** and select **Remove**.
- 2 Repeat above step if you want to remove more legs.

Saving as a route

- 1 Once you set all the legs, press **MENU** and select **Save**.
- 2 Enter a route name by pressing **▲** or **▼** to select a letter then press **▶** for next letter.
- 3 Press **↓** to save the new route.

 **Tip:** Bearing and distance

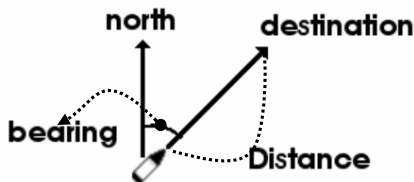

4-7-13 Projected course

The projected course shows you how far it can go at give time and speed. This function is very useful to avoid collusion with other vessels.

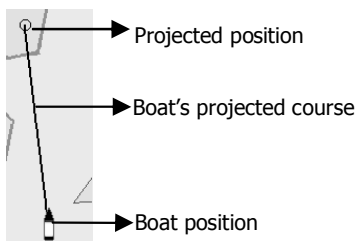

4-8 Highway

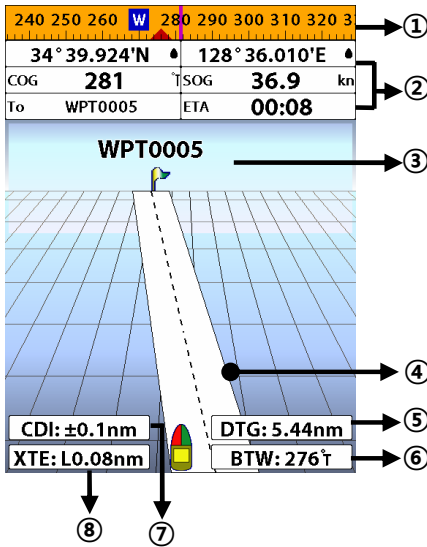

The **Highway** window shows a 3D view of the vessel traveling through the water when navigating to a destination point.

To go to the **Highway** window, press **PAGE** and select **Highway** icon.

The **Highway** window shows:

- ① Compass.
- ② Data bar.
- ③ Destination waypoint.
- ④ Boat's plotted course to destination.
- ⑤ DTG scale (Distance To Go).
- ⑥ BTW scale (Bearing to waypoint).
- ⑦ CDI (Course Deviation Indicator).
- ⑧ XTE scale (Cross Track Error).



4-9 Gauges

The **Gauges** window displays all the information you need during navigation such as water, engine, fuel related information, etc.

To select the **Gauges** window, press **PAGE** and select **Data** icon.

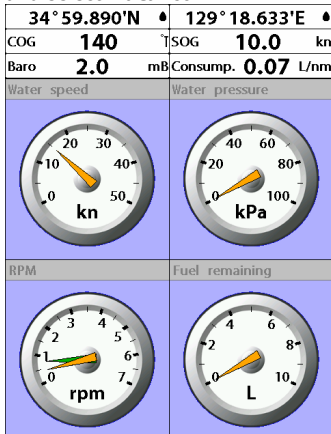

Selecting a Gauges layout

The **Gauges** window can show one of seven gauge layouts.

- To select a layout from the **Gauges** window:
- 1 Press **MENU** and select **Gauge Layout**.
 - 2 Select one layout.

Changing a gauge in one selected

To change a gauge displayed in a layout in Data display.

- 1 Press **MENU** and select **Gauge Setup** then the upper left side gauge will be highlighted.
- 2 Select a gauge you want to change and select Gauge type.
- 3 Select a data type you want to display.

4-10 Waypoints

A waypoint is a particular location on a voyage whether it is a starting, intermediate or destination point. A waypoint is the simplest piece of information the unit requires to get you to a destination in the shortest distance possible. This unit can save up to 10,000 waypoints.

To display waypoint list, press **PAGE** and select **Waypoint** icon.

Waypoints					
NAME	Latitude	Longitude	DST	rm	Dngr
			BRG	T	Disp
MOB0008	47°42.293N	003°22.081W	20.5	0.4	No
MOB0009	47°43.693N	003°21.553W	15.5	1.8	HN
MOB0010	47°43.242N	003°21.869W	11.8	1.8	No
MOB0012	47°43.693N	003°21.553W	15.5	1.8	HN
WPT0002	47°41.852N	003°21.556W	101.6	0.5	No
WPT0003	47°41.073N	003°21.696W	156.2	1.0	HN
WPT0004	47°41.315N	003°24.635W	248.2	1.7	No
WPT0005	47°42.899N	003°24.355W	304.1	1.7	HN
WPT0006	47°41.051N	003°22.326W	182.3	0.9	Yes
					HN

to select
 to Page Up/Down

4-10-1 Creating a new waypoint

To create a waypoint from the chart window

There are two ways to create a new waypoint from the chart window as described below:

- 1 Press **WPT** on at the current boat position.
- 2 Move the cursor to a point where you want to create a waypoint and press **WPT**.

To create a waypoint from the waypoints window

- 1 Press **MENU** and select **Create**.
- 2 Enter waypoint data, change alphanumerical name, choose between 48 icons, 16 colors and display option.
- 3 Select **Save**.

4-10-2 Moving a waypoint

To move a waypoint from the chart window

- 1 Move the cursor to place it on the waypoint you want to move. (If you move the cursor on the waypoint correctly, waypoint information will be displayed at the bottom left).
- 2 Press **MENU** and select **Move**.
- 3 Move the cursor to a point where you want to move and press .

To Move a waypoint from the waypoints window

- 1 Highlight a waypoint you want to move.
- 2 Press **MENU** and select **Edit**.
- 3 change the existing latitude and longitude to new position.
- 4 Select **Save**.

4-10-3 Editing an existing waypoint

To Edit a waypoint from the chart window

- 1 Move the cursor to the waypoint you want to edit. (If you move the cursor on the waypoint correctly, waypoint information will be displayed at the bottom left)
- 2 Press **MENU** and select **Edit**.
- 3 Edit waypoint data as you need and press .

To Edit a waypoint from the waypoints window

- 1 Move cursor key to highlight a waypoint you want to edit.
- 2 Press **MENU** and select **Edit**.
- 3 Edit waypoint data as you need and press .

4-10-4 Deleting a waypoint

To delete a waypoint from the chart window

- 1 Move the cursor to the waypoint you want to delete. (If you move the cursor on the waypoint correctly, waypoint information will be displayed at the bottom left)
- 2 Press **MENU** and select **Delete**.
- 3 Select **Yes**.

Deleting a waypoint from the waypoints window

- 1 Move cursor key to highlight a waypoint you want to delete.
- 2 Press **MENU** and select **Delete**.
- 3 Select **Yes**.

A waypoint can not be deleted if the final destination of navigation is the waypoint.

4-10-5 Find a waypoint

To find a waypoint from the chart window

Finding waypoints from the chart window is a simplified function.

- 1 Press **MENU** and select **Find**.
- 2 Select **Waypoints**.
- 3 Move cursor key to highlight a waypoint you want to find and press **↓**.

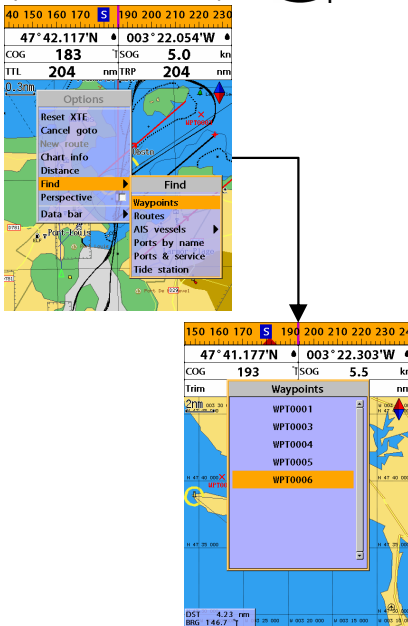

To find a waypoint from the waypoint window

Finding waypoints from the waypoint window is provided by a full function.

- 1 Press **MENU** and select **Find**.
- 2 Press **↑**, **↓**, **←** or **→** to find a waypoint name.
- 3 Select **↓**.

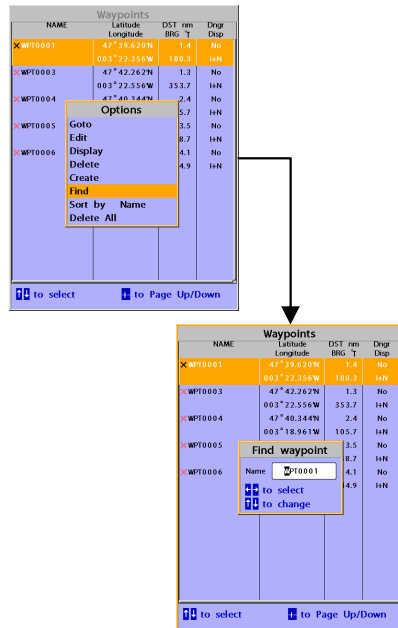

4-10-6 Sort Waypoints

To change the order of displayed waypoint list:

- 1 Press **MENU** and select **Sort by**.
- 2 Select a sort type.

4-10-7 Deleting all waypoints

- 1 In the waypoints window, press **MENU** and select **Delete all**.
- 2 Select **Yes**.

4-11 Routes

A trip from one place to another often involves several course changes, requiring a series of waypoints which you navigate to, one after another. The sequence of waypoints leading to the final destination is called a route. The unit can automatically advance to the next waypoint on a route. So you do not have to change the destination waypoint repeatedly.

The unit has the capability to store 100 routes with maximum of 100 waypoints each.

To display the **Routes** window, press **PAGE** and select the **Routes** window.

Routes				
Name	Start	End	Legs	DST(nm)
ROUTE 01	WPT0001	WPT0003	2	02.
ROUTE 02	WPT0003	WPT0006	3	10.
ROUTE 03	WPT0001	WPT0003	3	07.
ROUTE 04	WPT0003	WPT0006	3	10.

to select to Page Up/Down

4-11-1 Managing a route from the chart window

Creating a new route window

- 1 Press **MENU** and select **New route**.
- 2 Enter the new route name using cursor key and press **↓**.
- 3 On the **Chart** window, move the cursor to the position of the starting waypoint in the Route and press **↓**.
- 4 Move the cursor keys to the position of next waypoint and press **↓**.
- 5 Repeat step 4 to enter more waypoints.
- 6 Once you entered the last waypoint in the route, press **MENU** and select **End**.

Editing a waypoint in route while creating a route

- 1 Move the cursor to the waypoint you want to move.
- 2 Press **MENU** and select **Move**.
- 3 Move cursor to a position where you want to move the waypoint and press **↓**.

Deleting a last waypoint from the route while creating a route

- 1 Press **MENU** and select **Delete**.

Deleting a waypoint from the route while creating a route

- 1 Move the cursor to the waypoint you want to remove.
- 2 Press **MENU** and **Remove**.

Tip: Even though you deleted a waypoint in the route, the waypoint still remains in the waypoint list.

Inserting a waypoint while creating a route

- 1 If you want to insert a waypoint between waypoints which will be just after the one you want to insert.
- 2 Press **MENU** and select **Insert**.
- 3 Move the cursor to the new inserted waypoint and press **↓**.

Inserting a waypoint in front of starting waypoint while creating a route

- 1 Move the cursor to the starting waypoint
- 2 Press **MENU** and select **Insert**.
- 3 Move the cursor to the new start location and press **↓**.

Routes			
Leg	Waypoint	Distance(nm)	Bearing(°)
1	WPT0003		
2	WPT0005	3.8	239.0
3	WPT0006		114.9
4			

Insert waypoint

- WPT0001
- WPT0003
- WPT0004
- WPT0005
- WPT0006
- WPT0007
- WPT0008
- WPT0009
- WPT0010
- WPT0011
- WPT0012
- WPT0013

to Page Up/Down

to Page Up/Down

4-12 Satellites

4-12-1 Satellite information

Acquiring GPS signals

When the unit is first turned on it will take some time for the GPS signal acquiring. After signals are received, the unit will automatically find a position of boat in the chart window.

Satellite information window

The satellite window displays different information about the GPS satellites and GPS position as below.

To go to the satellite window, press **PAGE** and select **Satellite** icon.

The satellite window shows:

- ① Ship's Coordinates.
- ② Time received GPS satellites.
- ③ Date received GPS satellites.
- ④ HDOP: Horizontal Dilution of Precision. It is a parameter indicating the accuracy of the GPS.
- ⑤ Location of GPS Satellites.
- ⑥ GPS signal strengths status in graph.

Press  to display GPS signal information from GPS satellite in NMEA0183 data format at the GPS signal strengths status display.

To return to GPS signal strengths status display, press  again.

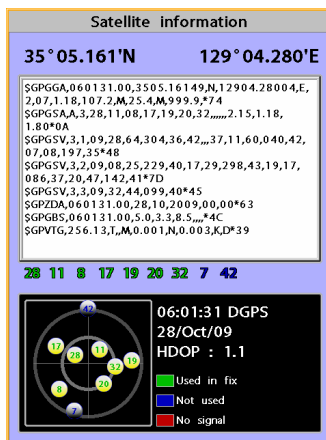
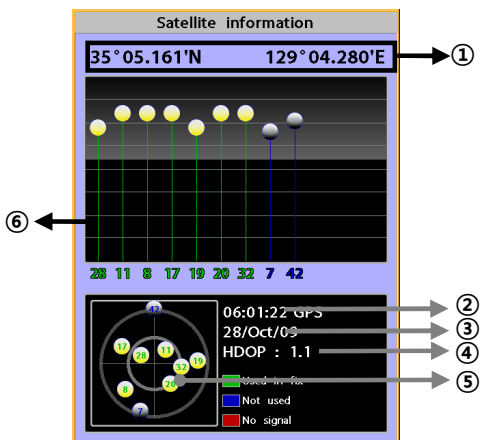



4-13 Tides

The **Tides** window is useful for boaters that are concerned about the height of the water or by fisherman that wish to know the tide and moon phase of a specific date.

Displaying a tide information from the chart window

- 1 In the **Chart** window, press **MENU**.
- 2 Select **Find and Tide station**.
- 3 Press **▲** or **▼** to move cursor and select a tide station
- 4 Press **▲**, **▼**, **◀** or **▶** to the position of selected tide station and press **↵**.
- 5 Select **Tide height station** to display the information
- 6 Press **ESC** to exit.

Displaying tide station information in the tides window

- 1 Press **PAGE** and select **Tides** window.
- 2 Select **Tide height station** to display the information.
- 3 Press **ESC** to exit.



Tip: The unit only displays the tide information nearest your boat in the tides windows.

Choosing the date of the tide information.

- 1 In the **Tides** window, Press **MENU** and select one of the following options.
 - **Set date:** manually set a date.
 - **Today:** automatically set the date of today.
 - **Next day:** automatically set the date of today.
 - **Prev day:** automatically set the date of yesterday
- 2 Press **ESC** to return to the window.

The tides window shows data for the chosen date

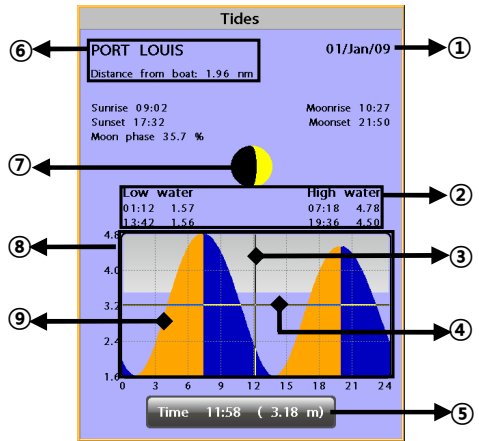

- ① Current time and chosen date for display.
- ② Data for the chosen date.
- ③ Tide height cursor, a horizontal dotted line. Press **▲** or **▼** to move cursor up and down.
- ④ Time cursor, a vertical dotted line. Press **◀** or **▶** to move cursor sideways.
- ⑤ Time of cursor and tide height at that time.
- ⑥ Tide station name and distance from boat.
- ⑦ Moon phase for moon at the current time on the chosen date.
- ⑧ Tide chart.
- ⑨ Tide height.

4-14 AIS

AIS is an Automatic Identification System for identification and localization of boat. AIS provide a means for boats to exchange and share boat data including identification, position, course, etc. This information can be displayed on the screen of your unit. AIS is intended to assist you to monitor other boats movements to improve safety and prevent collision.

AIS functions require an optional AIS unit to be installed. Contact your nearest Samyung ENC dealer for more details or visit at www.samyungenc.com.

To activate AIS function:

- 1 Press and hold **MENU** and select **System Configuration** icon.
- 2 Select **Features** then **AIS**.

4-14-1 Viewing AIS Vessels

When the unit is connected to AIS unit which support NMEA0183 or NMEA2000, you can check other vessel that are equipped with AIS unit on the screen. To check AIS information place the cursor on the AIS object then AIS information displays at the bottom of window.

- ① AIS equipped vessel
- ② Dangerous Vessel
- ③ Projected Course
- ④ AIS equipped vessel Data Box
- ⑤ Range Rings

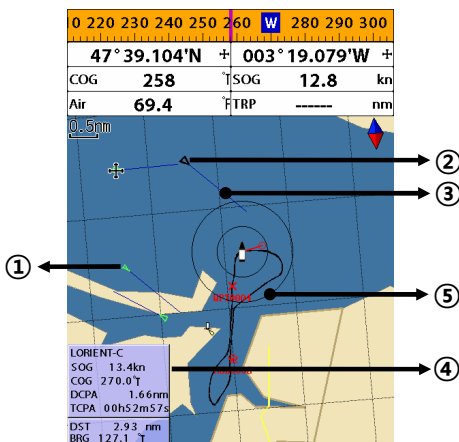

4-14-2 AIS Windows

To display the AIS windows:

- 1 Press **PAGE**, and select **AIS** icon.
- 2 Press and hold **PAGE** to select one of the two tabs: **Vessels** or **Messages** tab.
 - **Vessel:** show you all the AIS equipped vessel around you. (up to 200 vessels)
 - **Message:** show you all the messages related to safety from other AIS equipped vessels.

Sorting Vessels

- 1 Press **MENU**, select **Sort by**.
- 2 Select one of the options.

Displaying an AIS vessel on the chart

To overlay AIS equipped vessel on the chart window:

- 1 Press **▲** or **▼** to select a vessel you want to display in **AIS** window.
- 2 Press **MENU** and select **Display**.

Displaying AIS equipped vessel Details

- 1 Press **▲** or **▼** to select a vessel you want to display full AIS detail in the **AIS** window.
- 2 Press **↓** or press **MENU** and select **More Info**.
- 3 Press **←** or **→** to see more detail.

4-15-2 Poll

Poll

A compatible radio with the unit can request the position of other DSC VHF radio equipped vessels around its position. When the position of a vessel is received, the location is displayed on the screen and it is logged into Poll window

To display the **Poll** tab, press and hold **PAGE**.

Displaying an poll vessel in the chart window

- 1 Highlight a poll you want to display.
- 2 Press **MENU** and select **Display**.

Going to the poll vessel position

- 1 Highlight a poll you want to go.
- 2 Press **MENU** and select **Goto**.

Edit a distress waypoint

- 1 Highlight a poll you want to edit.
- 2 Press **MENU** and select **Edit Waypoint**.
- 3 Change data field and select **Save**.

 **Tip** : When receiving a poll from other vessel, it does not create a waypoint as a distress call

Deleting a poll

- 1 Highlight a received distress call you want to delete.
- 2 Press **MENU** and select **Delete**.

Deleting all poll

- 1 Press **MENU** and select **Delete all**.

 **Tip**: Even though you delete a DSC call, the DSC waypoints still exist.

DSC		
Distress	Poll	
Date Time	Latitude Longitude	MMSI NAME
01/01/2009 12:42	36° 24.000'N 129° 34.000'E	111111111 ———



4-16 NAVTEX

NAVTEX is an international automated direct printing service for delivery of navigational and meteorological warnings and forecast, as well as urgent marine safety information.

NAVTEX functions require an optional NAVTEX receiver with NMEA0183 output to be installed and connected to the chart plotter.

To go to the NAVTEX window, press **PAGE** and select the **NAVTEX** icon.

NAVTEX		
Time	MsgID	Freq
10:51 24/Jan/09	IE03	518kHz
12:02 24/Jan/09	AC05	518kHz
10:20 24/Jan/09	UL13	518kHz

ISSUED ON SATURDAY 24 JANUARY 2009.
 INSHORE WATERS FORECAST TO 12 MILES
 OFFSHORE FROM 1700 UTC TO 0500 UTC.

NORTH FORELAND TO SELLEY BILL.
 12 HOURS FORECAST:
 SHOWERY WINDS, STRONGEST IN NORTH.

Reloading NAVTEX messages

NAVTEX messages need to be loaded from NAVTEX receiver manually. (Up to 50 messages)

1 Press **MENU** and select **Reload all**.

Deleting a message

- 1 Move the cursor to a message you want to delete.
- 2 Press **MENU** and select **Delete**.

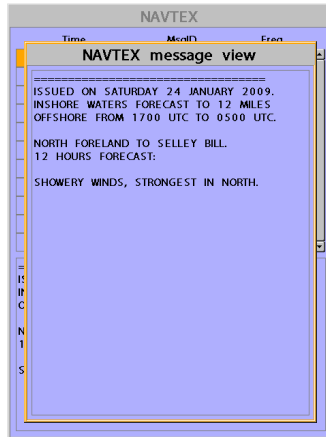

4-17 Engine Faults

Engine faults window show you all the errors or malfunctions of relating to the engine in real time. If any reason causing a problem is solved then corresponding error or malfunction indication will disappear.

5 Advanced Settings

The system menu mainly consists of settings which do not require frequent adjustment. To go to system menu, press and hold **MENU** then select the icon you want.

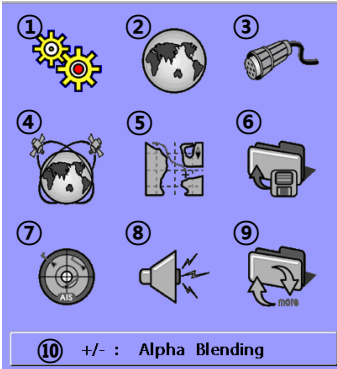

- ① System Configuration.
- ② Chart.
- ③ Comms.
- ④ GPS.
- ⑤ Track & log.
- ⑥ Memory.
- ⑦ AIS.
- ⑧ Alarms.
- ⑨ Others.
- ⑩ Set Alpha blending (set transparency of menu boxes' background over main windows)

5-1 System Configuration Settings

To go to **System configuration**:

- 1 Press and hold **MENU**.
- 2 Select the **system configuration** icon.

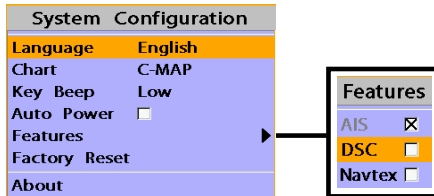

5-1-1 Language

Change the language for menus and data screens.

5-1-2 Chart Selection

Select a chart between S-MAP or C-MAP chart.

5-1-3 Beep volume

Select the level of beep sound.

5-1-4 Auto power

See section 2-4.

5-1-5 Features

When external devices are connected to the unit, the corresponding options need to be set.

5-1-6 Factory reset

When this option is selected. All settings of this unit returns to default factory settings.

5-1-7 About

This shows factory information:

- 1 Software version & sale date
- 2 C-Map version.
- 3 Wiring information of connector

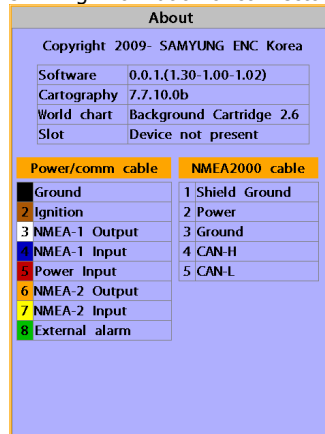

5-2 Chart Settings

To go to the chart settings:

- 1 Press and hold **MENU**.
- 2 Select the chart icon.

Chart	
Rotation	North up
Palette	Normal
General	
Land & Sea	
Map Datum	WGS84
NMEA datum offset	<input type="checkbox"/>
Map shift	Off
Restore default	

C-MAP

General		Land & Sea	
Plotter mode	<input checked="" type="checkbox"/>	Water features	<input checked="" type="checkbox"/>
Mixing levels	<input checked="" type="checkbox"/>	Object depths	<input checked="" type="checkbox"/>
AntiClutter	<input checked="" type="checkbox"/>	Spot soundings	<input checked="" type="checkbox"/>
Value added data	<input checked="" type="checkbox"/>	Sounding min	0 ft
Lat/lon grid	<input checked="" type="checkbox"/>	Sounding max	10 ft
Boundaries	Auto	Tidal stream	<input checked="" type="checkbox"/>
Text/icon Size	Small	Land features	<input checked="" type="checkbox"/>
Names	<input checked="" type="checkbox"/>	Land elevation	<input checked="" type="checkbox"/>
Nav-aids & Light Sector On	<input checked="" type="checkbox"/>	Security navigation zone	<input checked="" type="checkbox"/>
Nav-aids	INT		
Attention areas	<input checked="" type="checkbox"/>		
Projected course	Off		
CDI scale	0.1 nm		

Security navigation zone	
Enabled	<input checked="" type="checkbox"/>
Value	5 ft

S-MAP

General		Land & Sea	
Lat/Lon grid	<input checked="" type="checkbox"/>	Land	6
Depth Digit	<input checked="" type="checkbox"/>	Mud	4
Lighthouse	<input checked="" type="checkbox"/>	Rocky	5
Buoy	<input checked="" type="checkbox"/>	5 m	13
Wreck Ship	<input checked="" type="checkbox"/>	10 m	12
Fish Haven	<input checked="" type="checkbox"/>	Sea	
Sea Lane	<input checked="" type="checkbox"/>	20 m	3
Restricted Area	<input checked="" type="checkbox"/>	30 m	9
Fishing Area	<input checked="" type="checkbox"/>	50 m	13
Sea Cable	<input checked="" type="checkbox"/>	100 m	12
Name	<input checked="" type="checkbox"/>	200 m	6
Mark Attribute	<input checked="" type="checkbox"/>	300 m ~	7
Sea Sector No	<input type="checkbox"/>		
EEZ Area	<input type="checkbox"/>		
Projected course	Off		
CDI scale	0.1 nm		

5-2-1 Rotation

Three types of display presentations are provided. The default is heading up.

North up: North is at the top of the display.

Heading up: When course is set, the course is at the top of screen all the times.

Course up: When destination is set it is at the top of the screen. This option is only available when you are navigating to a destination.

5-2-2 Palette

Palettes are used to enhance the visibility of the display depending on the surrounding light environments. Four types of displays are provided; Normal, NOAA, Sunlight and Night.

5-2-3-1 General(C-MAP)

Plotter mode: this mode allows you to zoom in and out at scales where cartographic data are not available.

Mixing levels: when the map coverage at the current chart scale does not fill the entire display, the GPS chart plotter draws the rest of map using charts from above and below the current scale. When this function is turned on you will notice the display may redraw 2 to 3 times to show all the detail.

AntiClutter: when this option is selected, less important information (names & icons) are hidden when they are overlapped.

Value added data: The Value Added Data(VAD) is a collection of additional cartographic objects which are not present on the original paper chart. These objects have been obtained from other sources and then merged to the electronic charts in order to provide more information useful for the navigation.

Lat/Lon Grid: Turns the displaying of the latitude and longitude grid lines on or off on the chart window.

Boundaries: Turns the displaying of chart boundaries on, off or auto mode which shows the chart boundaries of the two charts below the current scale.

Text/Icon Size: change the size of text and icon on the chart.

Names: Display area names in the chart.

Nav-aids & Light Sector: Turns the presentation of Light, Signals, Buoys and Beacons On, Off, No Sector (Nav-Aids are shown, Light Sectors are hidden) or Animated (The lights are flashed).

Nav-aids: The way to display fog, radar and radio station signals. (International and US)

Attention areas: Turns the displaying of Attention Areas where need to pay attention more) On or Off.

Projected course: Display the Projected course in given set time.

CDI scale: Set CDI (Course Deviation Indicator) scale which is a parallel line on either side of the potted course.

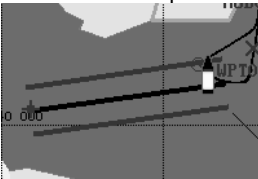

5-2-3-2 General(S-MAP)

Lat/Lon grid: Turns the displaying of Lat/Lon on or off

Depth Digit: Turns the displaying of water depth on or off

Lighthouse: Turns the displaying of Lighthouse on or off

Buoy: Turns the displaying of buoys on or off

Wreck Ship: Turns the displaying of Wreck Ship on or off

Fish Haven: Turns the displaying of Fish Haven on or off

Sea Lane: Turns the displaying of Sea Lane on or off

Restricted Area: Turns the displaying of Restricted area on or off

Fishing Area: Turns the displaying of Fishing Area on or off

Sea Cable: Turns the displaying of Sea Cable on or off

Name: Turns the displaying of area name on or off

Mark Attribute: Turns the displaying of Mark Attribute on or off

Sea Sector No: Turns the displaying of Sea Sector No on or off

5-2-4-1 Land & Sea (C-MAP)

Water features: Turns the displaying of sea bed nature and tide stations icon on or off.

Object depths: Turns the displaying of object depths on or off.

Spot soundings: Turns the displaying of spot sounding on or off.

Sounding min: Set the minimum depth limit to show depth sounding, bathymetric lines and depth area.

Sounding max: Set the maximum depth limit to show depth sounding, bathymetric lines and depth area.

Tidal stream: Turns the displaying of tidal streams on or off.

Land Features: Turns the displaying of land features on or off.

Land elevation: Turns the displaying of land elevations on or off.

Safe Navigation Area: Set the water depth for safe navigation and displaying safe navigation area in color.

5-2-4-2 Land & Sea (S-MAP)

Turns the displaying of sea color in 16 different colors.

5-2-5 Map datum

This unit has a compatibility with most of major chart system and this option allows you to select a map datum. The default datum is WGS84.

Map datum Selection

- 1 Press and hold **MENU** and select chart icon
- 2 Select general and Map datum
- 3 Select a desired map datum

5-2-6 NMEA datum offset

When you select other Map datum different from WGS84, latitude and longitude will be different from WGS84'S coordinates and this might confuse other device such as VHF radio if connected to the unit. If this option is applied, latitude and longitude send on the unit NMEA output will be the same as coordinates in WGS84.

5-2-7 Map shift

Sometimes current position of own ship does not match with the current location on the chart. To correct this position error, you can apply a map shift.

Applying a map shift

- 1 In the Chart setup menu, press and hold **MENU** and select **Chart** icon.
- 2 Select Map shift to **ON**.
- 3 Move cursor to the actual position on the chart.
- 4 Press **MENU** and select **Set**.

Canceling a map shift

- If you want to clear the map shift:
- 1 In the Chart setup menu, select **Map shift**.
 - 2 Press **MENU** and select **Clear**.

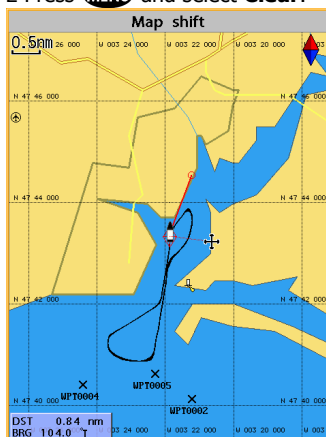

5-2-8 Restore default

Returns every chart settings to default.

5-3 Communication setup

When this equipment is connected to marine communication equipments through compatible NMEA equipment, you can use this function.

You can use as follows.

- 1 Push  long.
- 2 Select communication icon.

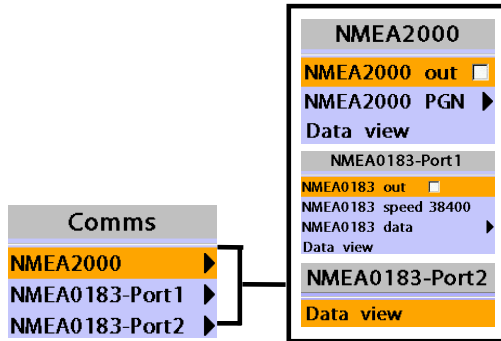

5-3-1 NMEA 2000

Communication with other equipments by NMEA 2000 method.

- **NMEA 2000 output:** Select, if you want to output data.
- **NMEA 2000 PGN:** User select the data item, which he wants to output
- **View:** You can check data, output in real-time.

5-3-2 NMEA 0183-Port 1

Communication with other equipments by NMEA 0183 method.

- **NMEA 0183 output:** Select, if you want to output data.
- **NMEA 0183 speed:** You can set up the speed of data output.
- **NMEA 0183 selection:** User select the data item, which he wants to output
- **View:** You can check data, output in real-time.

5-3-3 NMEA 0183-Port 2

This is used exclusively for AIS, always output AIS message.

- **View:** You can check data, output in real-time.

5-4 GPS Settings

To go to the GPS settings:

- 1 Press and hold **MENU**.
- 2 Select the **GPS** icon.

GPS	
GPS source	Internal
DGPS source	None
Static navigation	Off
Speed filter	Off
Course filter	Off
Lat/Lon d.p's	3
Ship speed	Fast
Magnetic Variation	

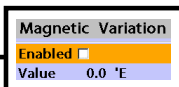

When the GPS device is connected properly, the GPS settings provide the access to GPS functions and features connected with the satellites information used for further navigation.

5-4-1 GPS Source

Select a source of GPS signals

Internal: Select this option when uses the internal GPS antenna.

NMEA0183 & NMEA2000: Select this option when using an external GPS or DGPS antenna via NMEA.

5-4-2 DGPS Source

Select WAAS/EGNOS when you want to utilize DGPS.

5-4-3 Static Navigation

This option is very useful when the boat stops or moves very slowly. This option allows you to set a minimum speed at which movement is assumed. The value range is from 0.00 to 9.99.

5-4-4 Speed Filter and Course Filter

Occasional waves and wind at sea affect the boat speed and course. In order to have stable boat speed and course, the unit calculates these factors to give the value of stable speed and course information.

5-4-5 Lat/Lon d.p's

Select number of last digit of Lat/Lon to be sent to other marine electronics.

5-4-6 Ship speed

To have more precise boat speed and course, you can select your boat speed. Mid is highly recommended option for the most of common boat.

5-4-7 Magnetic Variation

This option compensates the difference between true north and magnetic north.

5-5 Track & Log Settings

To go to the tracking and long settings:

- 1 Press and hold **MENU**.
- 2 Select the **track & log** icon.

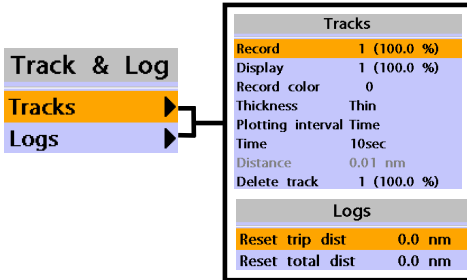

The unit has the capability to store 10 individual tracks and record up to 15,000 track points. Before using the track function you will need to setup the track function that suits your boat.

5-5-1 Track

Record

Off: Stop a recording of Track
1 to 10 (select a track number): Start a recording of the boat's course.

Display

Off: Display no track on the chart.
1 to 5 (select a track number): Display a selected track on the chart.

Record color

Select the color of recording track.

Thickness

Select the thickness of recorded track.

Plotting Interval

Select the method of plotting interval between time and distance.

Distance

Select the distance of plotting interval.

Time

Select the time of plotting interval.

Delete track

Delete a selected track record.

5-5-2 Logs

Reset trip dist

Shows you the trip distance. If you select this option it resets the trip distance.

Reset total dist

Show you the total trip distance. If you select this option it resets the total trip distance.

5-6 Memory Settings

To go to the memory settings:

- 1 Press and hold **MENU**.
- 2 Select the **Memory** icon.

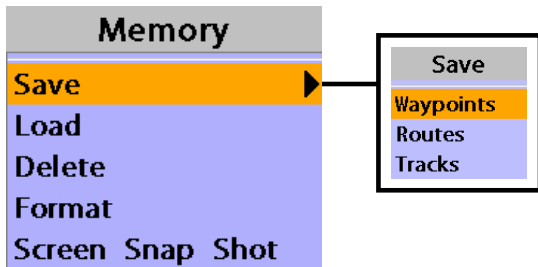

A user card is an option SD card which you need to purchase additionally. Before you use a user card it must be formatted. Note that formatting a user card erases all saved data.

5-6-1 Save

Select a data type you want to save in the user card then the data will be saved in the user card automatically.

- 1 If you select waypoint for saving data, enter the file name and press **↩**.
- 2 If you select routes for saving data, enter the file name and press **↩**.
- 3 If you select tracks for saving data, enter the file name and press **↩**.

[Waypoints]



[Tracks]

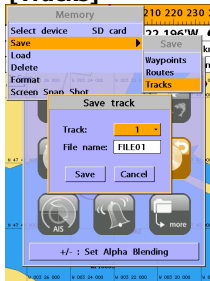

5-6-2 Load

Select a data you want to load into the load list then press **↵**.

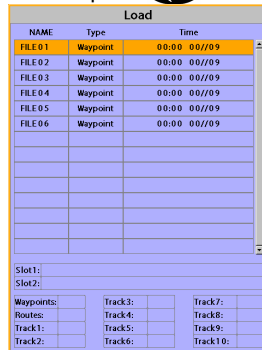

5-6-3 Delete

Select a data you want to delete then press **↵**.

Also, you can sort the file by name. Press **MENU** and select **sort by name**.

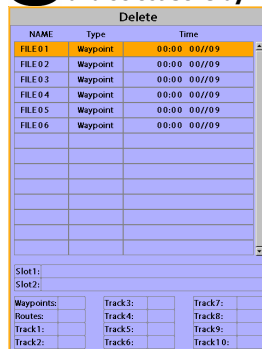

5-6-4 Format

Erase all data in the user card. Format the user card before using it.

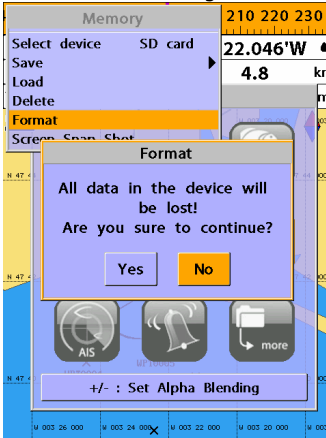

5-6-5 Screen snap shot

To take the snap shot of current screen, press **Ⓜ** twice. To save the captured image, press **MENU** and select **Save** or **Save all** to save the captured images on the user card.

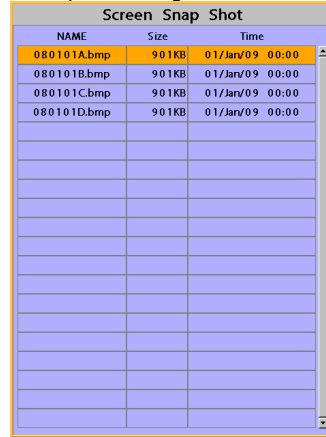

5-7 AIS Settings

Note

AIS feature require an optional AIS receiver.

To go to the AIS settings:

- 1 Press and hold **MENU**.
- 2 Select the **AIS** icon.

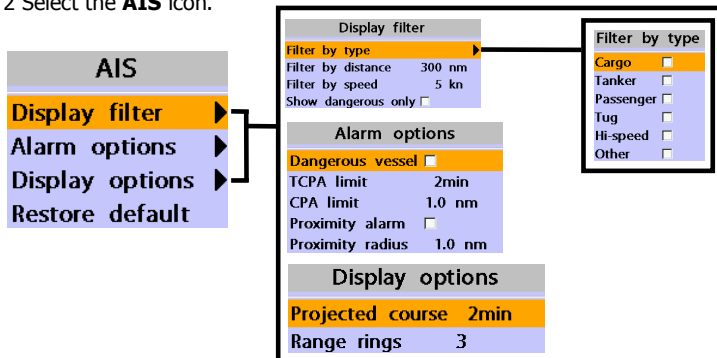

5-7-1 Display filter

There are a couple of methods to filter AIS vessel in this unit as below.

Filter by Type : The type of vessel which is selected will not be displayed on the chart.

Filter by distance : Vessels outside the radius of selected distance from own ship is filtered.

Filter by speed : Vessels with speed below the set value are filtered.

Show Dangerous Only : When this option is selected, it shows dangerous vessel only.

5-7-2 Alarm option

Dangerous Vessel Alarm : When this option is selected an alarm will activate. Even this option is not selected; dangerous vessels will still be on the chart.

TCPA Limit : Set the Time of Closet Point of Approach limit.

CPA Limit : Set the Closet Point of Approach limit.

Proximity alarm : Trigger an alarm when any AIS equipped vessel is within a set proximity radius.

Proximity radius : Set a radius for proximity alarm.

5-7-3 Display options

Projected course : Set a time for projected course. The project course show the estimate course of vessel base on the given time.

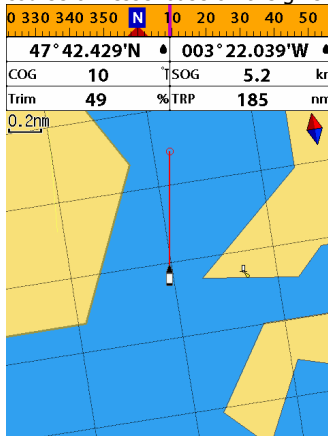

Range rings : Select a number of Range rings.

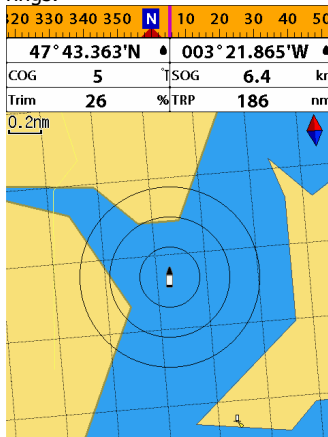

5-7-4 Restore default

Returns every AIS setting to default.

5-8 Alarms

Press and then **Alarms**:

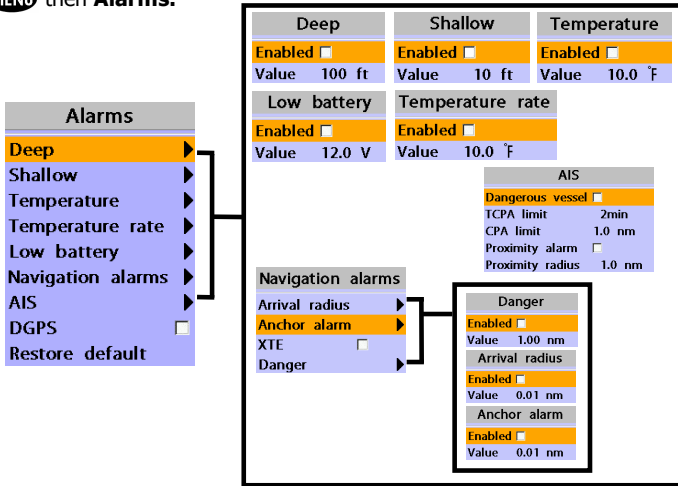

A warning message with beep sound is displayed when an alarm condition is met by user setting. Press to clear the alarm. However, the alarm will be displayed again when the alarm condition occurs again. The unit provides alarms for various functions.

5-8-1 Fish

Trigger an alarm when echo from the sensor is matched to preprogrammed fish profile.

5-8-2 Deep

Trigger an alarm when the depth value received from the sensor is deeper than a set value.

5-8-3 Shallow

Trigger an alarm when the depth value received from the sensor is shallower than a set value.

5-8-4 Temperature

Trigger an alarm when the reported temperature from the sensor is same as a set value.

5-8-5 Temperature rate

Trigger an alarm when the rate of temperature change from the sensor is same as a set value.

5-8-6 Low battery

Trigger an alarm when battery voltage is lower than a set value.

5-8-7 Navigation alarms

Arrival radius : Trigger an alarm when your boat is approaching the destination to set value

Anchor alarm : Trigger an alarm when your boat moves more than set valve

XTE : Trigger an alarm when your boat moves off the current CDI scale.

Danger : Trigger an alarm when your boat is getting closed to dangerous point.

5-8-8 AIS

See the Alarm option of 4-7 (AIS Settings).

5-8-9 DGPS

Trigger an alarm when DGPS signal is not received.

5-8-10 Restore default

Returns every alarm settings to default.



5-9 Others

Press and then **Others**:

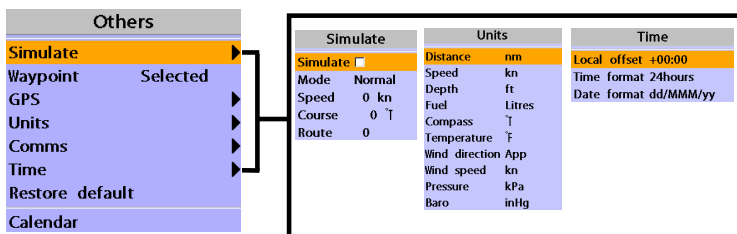

5-9-1 Simulate

simulation: Start/end exercise mode.

mode: Refer to exercise mode of 4-2.

speed: Simulated boat speed

direction: Simulated course

route: route to follow

5-9-2 Waypoint

Select a way to display waypoints.

5-9-3 GPS

5-4 Refer to GPS setup.

5-9-4 Units

Select units of each number.



Tip: air pressure

VHF receiver of the option, connected to barometer, is required: InHg or mB

5-9-5 Comms

5-3 Refer to communication setup.

5-9-6 Time

local time

Change the sunrise & sunset time of chart in order to read correct time, provided from GPS satellite.

time indication: Select time indicating form.

date indication: Select date indicating form.

5-9-7 Restore default

It initializes all the set up information.

5-9-8 Calendar

It provides calendar function.

6 INSTALLATION

Correct installation is important to the performance of the unit. It is vital to read the entire installation section of this manual and the documentation that comes with the antenna and any other units before starting installation. For further information, please contact Samyung ENC.

6-1 Options and Accessories

Optional sensors and instruments

- External alarms
- GPS or DGPS antenna
- Fuel sensors
- DSC VHF radio
- NMEA 2000: The chart plotter can display engine data and.
- Other instruments: The chart plotter can receive data from other instruments and send data to other instruments by NMEA.

6-2 Connections

You can connect AIS-50N to power supply, GPS antenna, VHF antenna, automatic navigation device, digital device, etc.

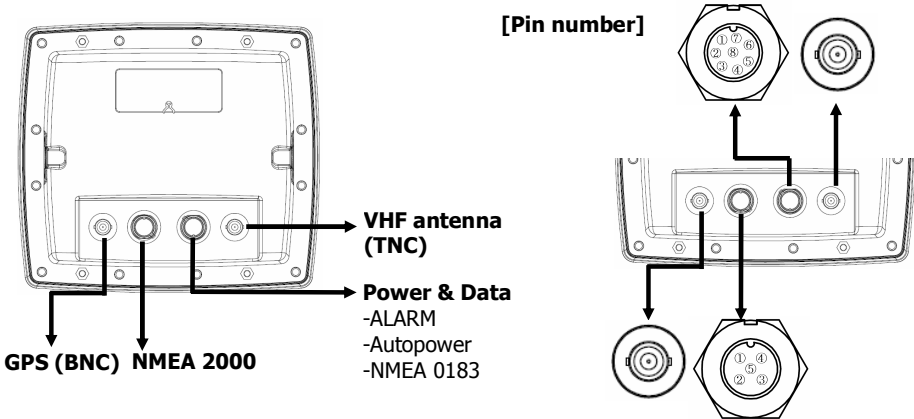

[Power & Data(ALARM, Auto power)]

Number	Color	Function
1	Black	Ground: - power in, NMEA ground.
2	Brown	Ignition_On
3	White	NMEA 1 Out (Plotter)
4	Blue	NMEA 1 In (Plotter)
5	Red	+ power in, 12 to 34 V DC
6	Orange	NMEA 2 Out (AIS)
7	Yellow	NMEA 2 In (AIS)
8	Green	External alarm

6-3 Power/data cable

Basic power

- Wire the display unit for basic power as below picture.

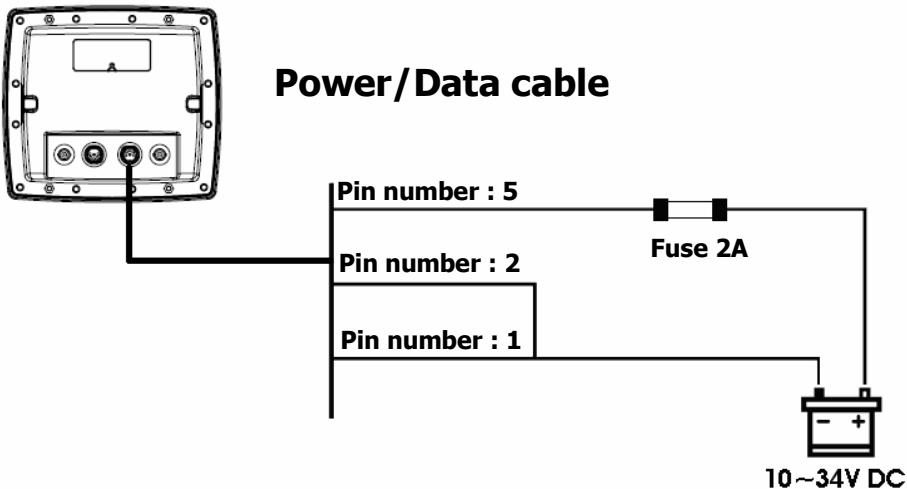

Auto power

- Wire the display unit for auto power as below picture.
- During setup, set up Auto power off.

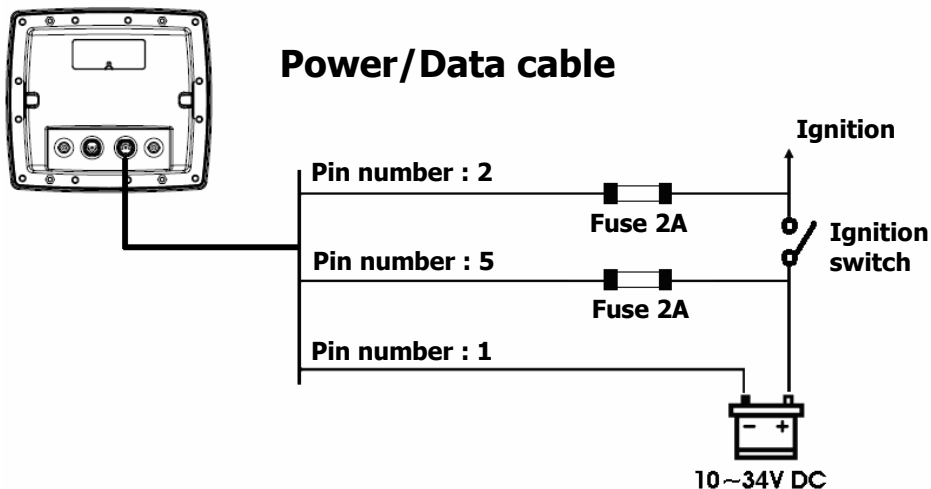

6-4 Alarm

- Wire the chart plotter for any external alarm beepers or lights as below picture.
- The output from the unit to external alarm is maximum 30V DC 200mA. It is needed to fit a suitable relay.

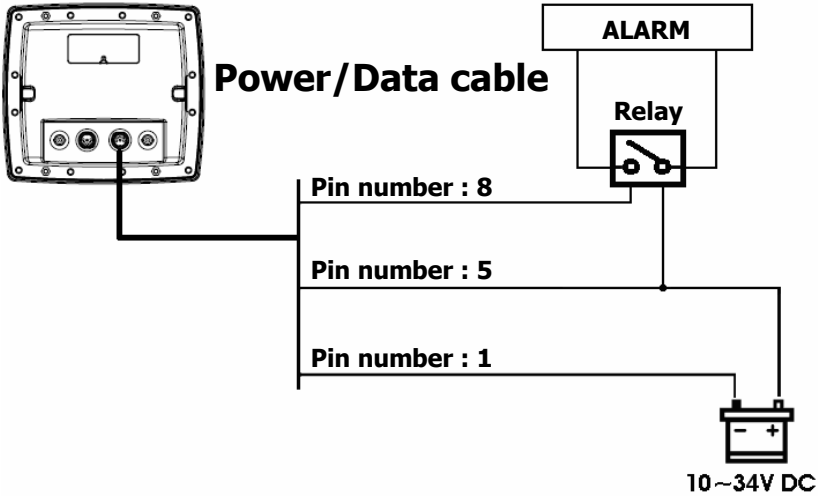

6-5 VHF antenna installation

VHF antenna play roles in stable communication of AIS-50N. Several important points in antenna installation are as follows.

- ▶ Normally VHF antenna should be installed at high position of vessel. It should be separated from other equipments as much as possible.
- ▶ VHF antenna should be separated from the structure of conductive materials. It should be laid at higher place by 2M at least. Besides, it should not be near big vertical objects. Also, it should have 360-degree horizontal view.
- ▶ VHF antenna should be separated from high pressure energy sources, such as radars, other transmitting radars, transmitting radio antenna by 2M at least. Also, it should be out of transmitting beam.
- ▶ At same height more than one antenna should not be installed. If VHF antenna is at the same height with other antennas, distance between antennas should be 2M at least.

VHF antenna installation is done as follows.

- ▶ Locate antenna installing bracket at structurally solid position.
- ▶ Install antenna on antenna mount-make coaxial cable from antenna reach the body position. In order to use high quality RG-8U coaxial cable & reduce the drop of electric current, keep the length of cables as short as possible.
- ▶ Give some space to the cable length toward body direction.
- ▶ Stick connector to the end of coaxial cable.
- ▶ Connecting cable to body, use TNC connector.

	<p>Please check the installation distance between VHF antenna & other equipments.</p> <p>GPS antenna : 5M</p> <p>Compass : 1M</p>
---	--

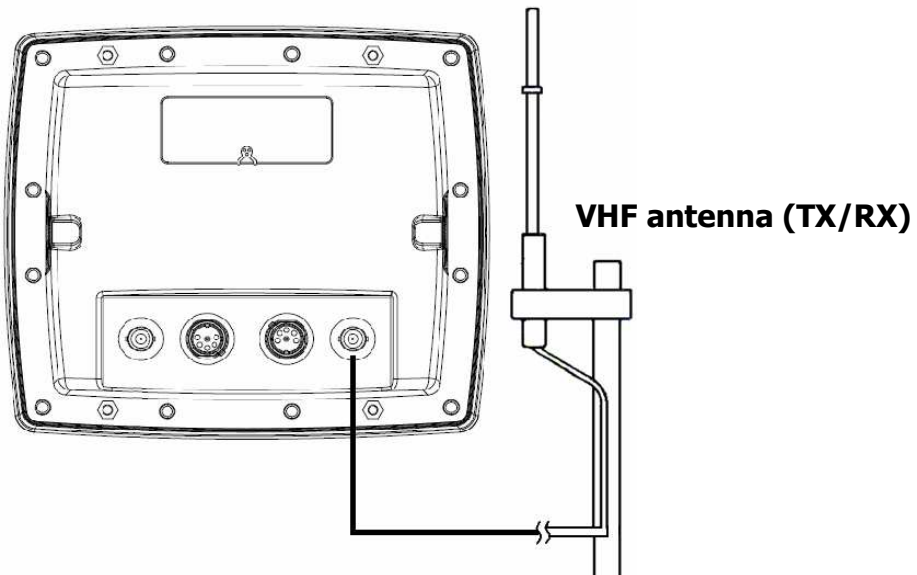

6-6 GPS antenna

Selecting an antenna

Fit one of these GPS antennas:

6-6-1 GPS antenna of BNC type

Position, where GPS antenna is installed, affects GPS receiving rate. Connector of connecting device is BNC type.

Antenna installation

Installation should be done where sky is open 360-degree. Proper distance should be kept between VHF antenna & compass.

For detailed installation method, please refer to SAMYUNG ENC or agencies.

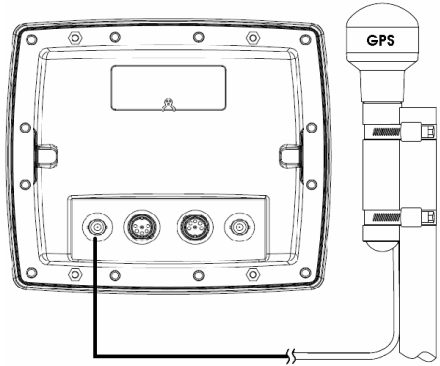

	<p>Please check the installation distance between GPS antenna & other equipments. VHF antenna : 3M Compass : 1M</p>
---	--

6-6-2 The antenna using NMEA

The chart plotter can receive the GPS data from the compatible device (NMEA). The chart plotter can connect several devices to an external GPS.

- An optional differential beacon DGPS antenna to give enhanced accuracy within range of land based differential beacons in areas where WAAS or EGNOS are not available. Such a DGPS antenna has both a GPS receiver and a beacon receiver, and it automatically applies the beacon correction to the GPS position.

To set the DGPS options(None or WAAS/EGNOS):

Connect the GPS directly to the input. Set the option. The new setting will be displayed if it was successfully applied.

Note:

The chart plotter can apply the WAAS and EGNOS DGPS corrections to any GPS antenna.

For more information, contact Samyung ENC.

6-7 NMEA 0183

The GPS chart plotter can be connected to external devices with NMEA0183 and display information such as followings.

- DSC VHF Radio
- GPS antenna(NMEA 0183)
- Navtex

Main functions of NMEA 0183 port in AIS-50N are as follows.

- ▶ **NMEA 0183(1):** Used as exclusive plotter port. Option device should be connected to (1), in order to use additional functions, provided from plotter, Navtex, DSC, etc.

- ▶ **NMEA 0183(2):** Used as exclusive AIS port. This outputs AIVDM, AIVDO messages of AIS.

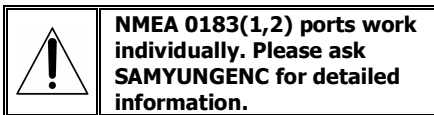

Input (1) NMEA 0183

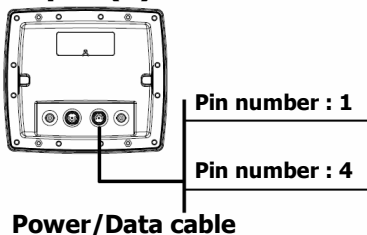

Output (1) NMEA 0183

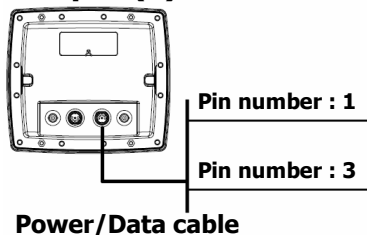

Input (2) NMEA 0183

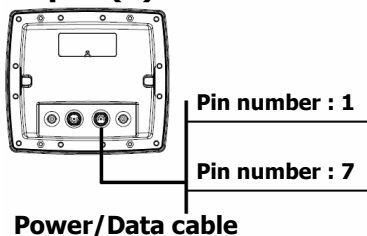

Output (2) NMEA 0183

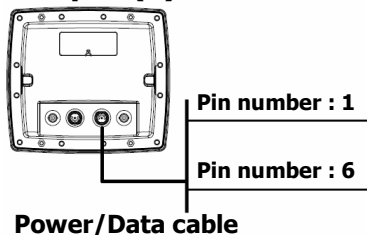

DSC VHF radio

Install DSC VHF wireless devices of option, referring to above NMEA 0183(1) input pictures.

Other NMEA instruments

NMEA is an industry standard for interconnecting instruments. The chart plotter can be connected to other NMEA instruments. Set up the optional NMEA instruments as above pictures.

- The chart plotter can receive and display depth, paddlewheel boat speed and water temperature from an optional compatible instrument.
- The chart plotter can receive data from an optional compatible GPS or GPS/DGPS source.

- The chart plotter can send GPS position and other navigation data to an autopilot or other instrument. An autopilot requires APB, APA and VTG sentences

For information on sending NMEA data to the instrument, contact Samyung ENC.

During setup to send NMEA data to other instruments, set NMEA out and specify the NMEA data to send.

6-8 NMEA 2000

NMEA 2000 interface standard was introduced for communications network to interconnect marine electronic equipments such as navigation chart plotter, engine, tank level sensor and others on vessels. The standard is regulated by The National Marine Electronics Association in USA.

The chart plotter can be connected to external devices with NMEA2000 and display information such as followings.

- Engines have fuel flow sensors, therefore fuel sensors are not required.
- The chart plotter can receive and display wind speed and direction from an optional compatible wind instrument.

- The chart plotter can receive and display depth from an optional depth instruments.
- The chart plotter can receive and display boat speed and water temperature from a paddlewheel sensor on a optional speed instrument.

If connected display unit, use the cable compatible with NMEA 2000 standard.

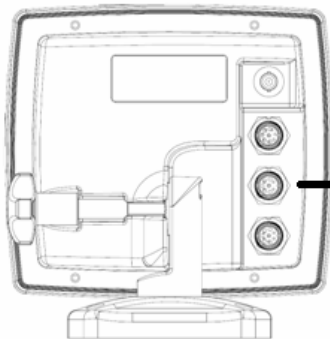

NMEA 2000

6-9 Setup and test

- 1 Put a blanking cap on any unused connector on the back of the display unit. Ensure all connectors are plugged in and the display unit is in place.
- 2 If the display unit is bracket mounted, adjust tilt and rotation for best viewing and hand tighten the knob.
- 3 Insert any required C-MAP chart card.
- 4 Enter setup data to set up the chart plotter to your requirements and to set up any optional sensors or instruments.
- 5 At the satellite display, check that it picks up GPS satellites. Wait for the GPS receiver to start up and the GPS satellite to change to 'Used in fix'.



Thank you for purchasing an SAMYUNG ENC product. This product has been thoroughly checked and is covered by the **Samyung ENC's warranty** for defects in materials and workmanship under normal use from the date of purchase.

This warranty provides for the free repair or replacement of defective parts from our Samyung ENC authorized dealer.

In the event that your SAMYUNG ENC product needs service, please return your SAMYUNG ENC product at your expense (shipping and insurance) to your Samyung ENC distributor or SAMYUNG ENC authorized Service Centers. SAMYUNG ENC will, at its discretion, repair or replace any defective products or its components at no cost to you. This is your exclusive remedy for defective products

Exclusions: are specifically excluded from warranty;

1. Consumable items, including, but not limited to: fuses, impellers, impeller bearings, impeller shafts are specifically excluded from this warranty. . .
2. All costs associated with transducer replacement, other than the cost of the transducer itself.
3. Routine system checkouts, alignment and calibration, seatrials, unless required by replacement of defective parts.

Limited warranty: SAMYUNG ENC will not be responsible for equipment that has been damaged or rendered defective:

1. as a result of incorrect installation, misuse, accident, water damage, abuse or other external causes
2. by modification or service other than by SAMYUNG ENC or authorized distributors, authorized Service Centers. SAMYUNG ENC will not be liable in any event for any consequential or indirect loss or damage. Exceptions are expressly set out in this warranty, SAMYUNG ENC makes no other warranties, express or implied, including any implied warranties of merchantability and fitness for a particular purpose. If any limitation or exclusion of liability in this warranty is invalid and SAMYUNG ENC becomes liable for loss or damage that would otherwise have been excluded, such liability will be limited to the total amount actually paid by you for the product.
3. if the serial number label on the unit has been removed, altered or mutilated

SAMYUNG ENC

www.samyungenc.com

 **SAMYUNG ENC Co.,Ltd.**

Head Office : 1123-17, Dongsam-Dong, Youngdo-Gu, Busan, Korea, 606-083 Tel : 82-51-601-5530(Rep.) Fax : 82-51-413-4446
A/S Center : 65-20, 2-Ga Namhang-Dong, Yungdo-Gu, Busan, Korea, 606-032 Tel : 82-51-601-5570-4(Rep.) Fax : 82-51-416-5515