

# User manual

## ADA-1021

### RS-232 to Current Loop Converter



## Contents

1. GENERAL INFORMATION.....	3
1.1. WARRANTED INFORMATION .....	3
1.2. GENERAL CONDITIONS FOR SAFE USE.....	3
1.3. CE LABEL.....	3
1.4. ENVIRONMENTAL PRESERVATION.....	3
1.5. SERVICE AND MAINTENANCE.....	3
2. PRODUCT INFORMATION.....	3
2.1. PROPERTIES.....	3
2.2. DESCRIPTION.....	4
2.3. CURRENT LOOP TRANSMITTER.....	4
2.4. CURRENT LOOP RECEIVER.....	4
2.5. ISOLATION.....	5
3. INSTALACJA.....	5
3.1. ASSEMBLING.....	5
3.2. CONNECTION OF DEVICES WITH RS232 PORT .....	5
3.2.1. CONNECTION OF DEVICES WITH RS232 PORT - DTE TYPE (COMPUTER).....	6
3.2.2. CONNECTION OF DEVICES WITH RS232 PORT - DCE TYPE (MODEM) .....	6
3.3. CONNECTION OF CURRENT LOOP DEVICES.....	7
3.3.1. CONNECTION TO DEVICE WITH PASSIVE TRANSMITTER & PASSIVE RECEIVER.....	7
3.3.2. CONNECTION TO DEVICE WITH ACTIVE TRANSMITTER & ACTIVE RECEIVER.....	7
3.3.3. CONNECTION TO DEVICE WITH ACTIVE TRANSMITTER & PASSIVE RECEIVER.....	8
3.3.4. CONNECTION TO DEVICE WITH PASSIVE TRANSMITTER & ACTIVE RECEIVER.....	8
3.4. CONNECTION TO COMPUTER.....	9
3.4.1. EXTENSION OF RS232 PORT OF PC.....	9
3.4.2. EXAMPLE CONNECTION OF CNC MACHINE CT40-CNC CONTROLEPL1 TO PC .....	9
3.5. POWER SUPPLY CONNECTION.....	10
4. ACTIVATION.....	10
4.1. LEDS DESCRIPTION.....	10
5. RS232 INTERFACE – PIN DESCRIPTION OF DSUB-9F-DCE SOCKET.....	10
6. VERSIONS.....	10
7. SPECIFICATION.....	11

## 1. GENERAL INFORMATION

Thank you for your purchase of **CEL-MAR Company** product. This product has been completely tested and is covered by a two year warranty on parts and operation from date of sale.

If any questions or problems arise during installation or use of this product, please do not hesitate to contact Technical Support at +48 41 362-12-46 or e-mail support@cel-mar.pl.

### 1.1. WARRANTED INFORMATION

**CEL-MAR Company** gives the indefinite guarantee on the **ADA-1021 converter**. The warranty does not cover damage caused from improper use, materials consumption or any unauthorized changes. If the product does not function accordance with the instructions will be repaired. All warranty and no warranty repairs must be returned with paid transport and insuring to the **CEL-MAR Company**.

**CEL-MAR Company** under no circumstances won't be responsible for ensuing damage from improper using the product or as a result of random causes: the lightning discharge, the flood, the fire and the like.

**CEL-MAR Company** is not be held responsible for damages and loss including: loss of profits, loss of data, pecuniary losses ensuing from using or the impossibility of using this product.

In specific cases **CEL-MAR Company** discontinue all warranties and in particular do not follow the user manual and do not accept terms of warranty by the user.

### 1.2. GENERAL CONDITIONS FOR SAFE USE

The device should be installed in a safe and stable places (eg, electroinstallation cabinet), the powering cable should be arranged so as not to be exposed to trampling, attaching, or pulling out of the circuit.

Do not put device on the wet surface.

Do not connect devices for nondescript powering sources,

Do not damage or crush powering wires.

Do not make connection with wet hands.

Do not adapt, open or make holes in casings of the device!

Do not immerse device in water or no other liquid.

Do not put the fire opened on device sources: candles, an oil lamps and the like.

Complete disable from the supply network is only after disconnecting the power supply circuit voltage.

Do not carry out the assembly or dis-assembly of the device if it is enabled. This may result to short circuit and damage the device.

### 1.3. CE LABEL



CE symbol on organizing the company CEL-MAR a conformity of the device to the directive of the electromagnetic EMC 2004/108/WE compatibility means (Electromagnetic Compatibility Directive). The declaration of the agreement is accessible through the contact with the technical service at the address e-mail: serwis@cel-mar.pl or on the phone at the +48 41 362-12-46.



### 1.4. ENVIRONMENTAL PRESERVATION

This sign on the device inform about putting expended device with other waste materials. Device should send to the recycling. (In accordance with the act about the Electronic Appliance Expended from day 29 of July 2005)

### 1.5. SERVICE AND MAINTENANCE

The ADA-1021 converter does not require the servicing and maintenance.

Technical support is available at number +48 41 362-12-46 in 8.00-16.00, from Monday to Friday or e-mail support@cel-mar.pl.

## 2. PRODUCT INFORMATION

The converter is delivered with User Manual.

### 2.1. PROPERTIES

- Operating on 4-wire network in Current Loop standard
- Conversion TX, RX signals of RS232 interface,
- Baud rate up to 38,4 Kbps (depending on the length of the line),
- Transparent for all protocols: MODBUS, DNP, PROFIBUS and other,
- Any format of transmission frame,
- 0-20mA Current Loop active/passive transmitter, active/passive receiver.
- External power supply from 10 to 30 VDC (standard) stabilized
- ~3kV= optoisolation in signal channel between RS232 and Current Loop interface,
- 1kV= or 3kV= galvanic isolation between RS232 interface and power supply,
- 1kV= or 3kV= galvanic isolation between Current Loop interface and power supply,
- Connection Current Loop line and power supply via screw terminal block,
- Connection RS-232 interface via DB-9F connector by the use of extension cable,
- Integrated short circuit protection and over-voltage protection on Current Loop lines,
- Protection against power supply reverse connection,
- DIN 43880 standard - mounting in typical electro-installation unit,
- Rail mounting according to DIN35 / TS35 standard,
- Dimensions (W x D x H) 53mm x 58mm x 90mm.

**2.2. DESCRIPTION**

Many devices such as PLCs, transducers, sensors, cash registers and electronic scales are equipped with as standard RS232 communication port. Standard of RS232 has restrictions on the length of the cable (the distance at which the transmission is working properly is 15m). The solution to this problem is to use for data transmission Current Loop interface. Current Loop Interface allows to connect with each other devices at up to several kilometres.

ADA-1021 converter is a device used to convert RS232 to Current Loop standard without interfering with data format. The converter does not require the power to his operation from the RS232 port, supports asynchronous RS232 data transmission at up to 38.4 kbps by two pairs of twisted-pair. ADA-1021 is equipped with a female DB-9F connector for RS232 interface connection and screw terminal blocks for twisted-pair connections of Current Loop and power supply. DB-9 connector is made as DCE which allows to connect the converter to the PC via the RS232 extension cable (a typical cable modem connection) without crossing Tx with Rx and RTS with CTS. For its operation uses the signals from the RX, TX and mass SG, entered by DB-9F connector to the converter. RTS signal is looped with CTS inside the converter and DTR with DSR and DCD. Others signals are not connected. If it is not needed looping the above signals, can be unsolder the RTS or DTR in the plug DB-9M (pins: RTS-7, DTR-4). To Current Loop line constructed on the ADA-1021 can be connected two converters operating in full duplex or half duplex point-to-point.

This converter has internal, low energy surge protection (600W overvoltage diodes) for each Current Loop lines however it is recommended to use the external lightning arresters (typical protection of telephone line) for the lightning protection of lines.

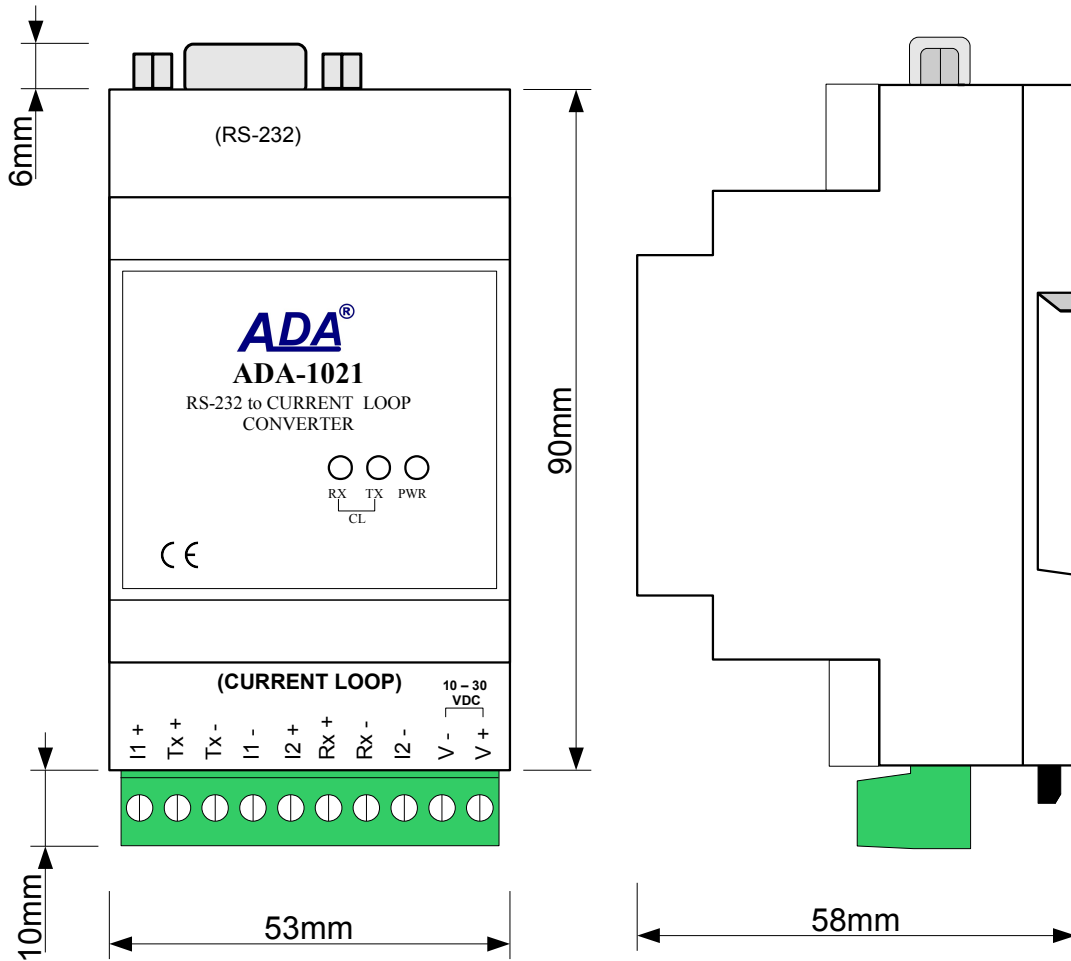

Fig. 1. View

**2.3. CURRENT LOOP TRANSMITTER**

The Current Loop transmitter in the ADA-1021 was made as a passive 0-20mA, having low energy short circuit protection on TX+ and TX- lines. By the correct connection of the transmitter with power source I1, Current Loop transmitter 0-20mA can operate as active. The transmitter diagram is shown on figure below.

**2.4. CURRENT LOOP RECEIVER**

The ADA-1021 converter has passive RX receiver having low energy short circuit protection on TX+ and TX- lines. By the correct connection of the receiver with power source I2, Current Loop receiver 0-20mA can operate as active. The receiver has signalization of non current flow through optocoupler. It is indicated by the red LED RX on front panel of the converter. This LED lit when it is:

- not connect transmitter to receiver,
- wrong connection of transmitter to receiver,
- broken connection of transmitter to receiver.

The diagram is shown on figure below.

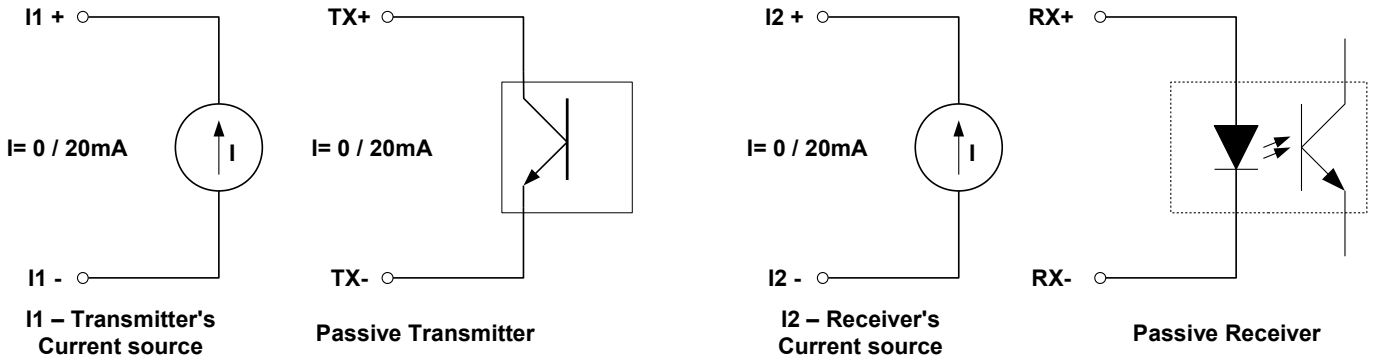

Fig. 2. Diagram of the transmitter & receiver ADA-1021 Current Loop

**2.5. ISOLATION**

Converter ADA-1021 has 3-way galvanic isolation on level 1kV= or 3kV=, depend on version described in section *VERSIONS*.

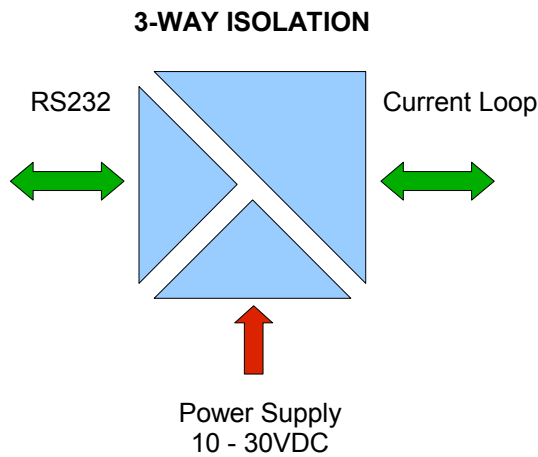

Fig. 3. Isolation structure

**3. INSTALACJA**

This chapter will show how to connect ADA-1021 to PC, Current Loop bus, RS232 bus and power supply and how to use it. In the purpose of minimization of disruptions from environment is being recommended to:

- apply multipair type shielded cables, which shield can be connected to the earthing on one end of the cable,
- arrange signal cables in the distance not shorter than 25 cm from powering cables,
- apply cable of adequate cross-section due to voltage drops for converter powering,
- use Interference suppression filters for power supply converters that are installed within a single object.
- not supply converter from power circuit device that generates large impulse interference such as transmitters, contactors,

**3.1. ASSEMBLING**

The ADA-1021 enclosure is adapted to assembly on TS-35 (DIN35) rail. To instal converter should the upper part of casing hang hooks on the rail, than push the lower part until to hearing characteristic "Click" sound.

**3.2. CONNECTION OF DEVICES WITH RS232 PORT**

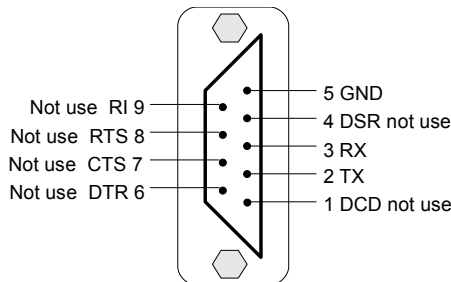

The Signals looped on the converter :  
1. DTR – DSR – DCD  
2. RTS - CTS

Fig. 4. RS232 interface signals of DB-9F (female) connector

**3.2.1. CONNECTION OF DEVICES WITH RS232 PORT - DTE TYPE (COMPUTER)**

In purpose of connecting ADA-1021 to RS232 port of computer, should be used the RS232 extension cable CAB-DB9F/DB9M-S-1,8m (available in CEL-MAR offer). Example connection is shown below.

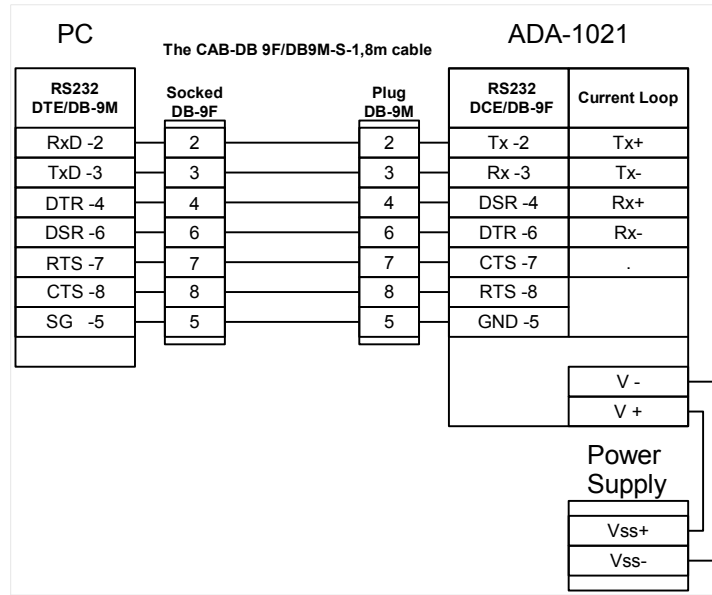

**Fig 5. Connection to RS-232 computer port**

**3.2.2. CONNECTION OF DEVICES WITH RS232 PORT - DCE TYPE (MODEM)**

In purpose of connecting ADA-1021 to RS232 port type DCE (eg modem), should be used the RS232 cable CAB-DB9M/DB9M-C-1,8m (available in CEL-MAR offer). Example connection is shown below.

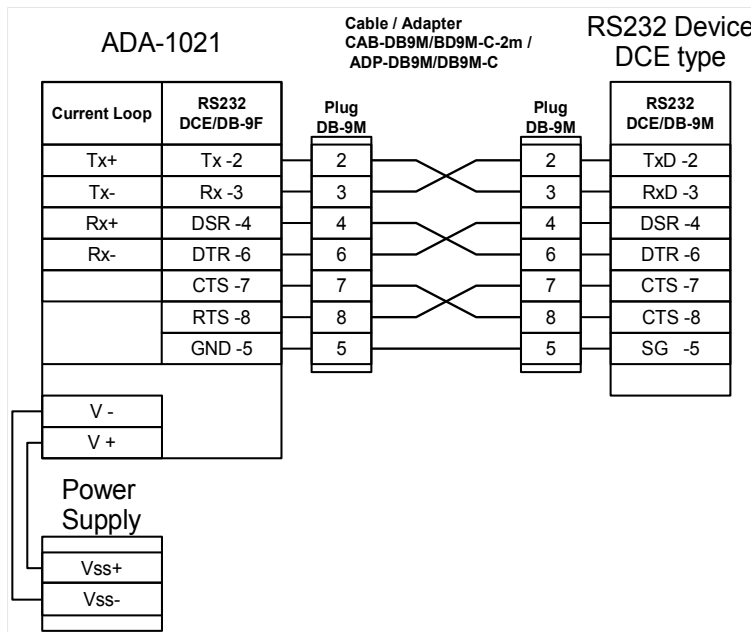

**Fig 6. Connection to device with RS232 type DCE**

**3.3. CONNECTION OF CURRENT LOOP DEVICES**

Current Loop line is connected to TX+, TX-, I1+, I1-, RX+, RX-, I2+, I2- terminals of converter as below.

**3.3.1. CONNECTION TO DEVICE WITH PASSIVE TRANSMITTER & PASSIVE RECEIVER**

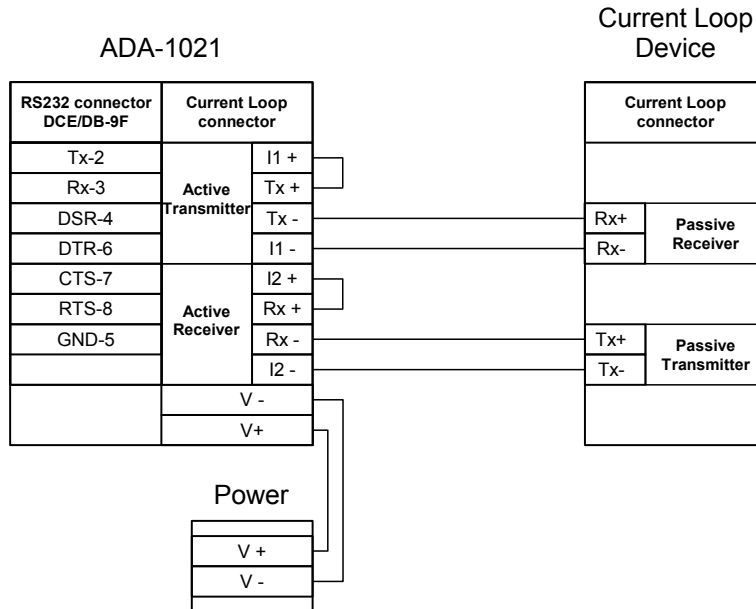

Fig. 7. Example connection of device with passive transmitter and passive receiver to ADA-1021

**3.3.2. CONNECTION TO DEVICE WITH ACTIVE TRANSMITTER & ACTIVE RECEIVER**

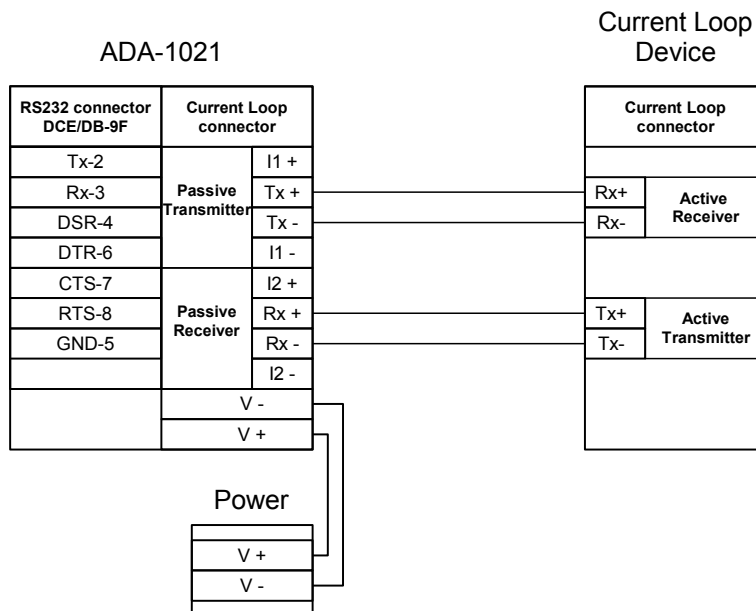

Fig. 8. Example connection of device with active transmitter and active receiver to ADA-1021

**3.3.3. CONNECTION TO DEVICE WITH ACTIVE TRANSMITTER & PASSIVE RECEIVER**

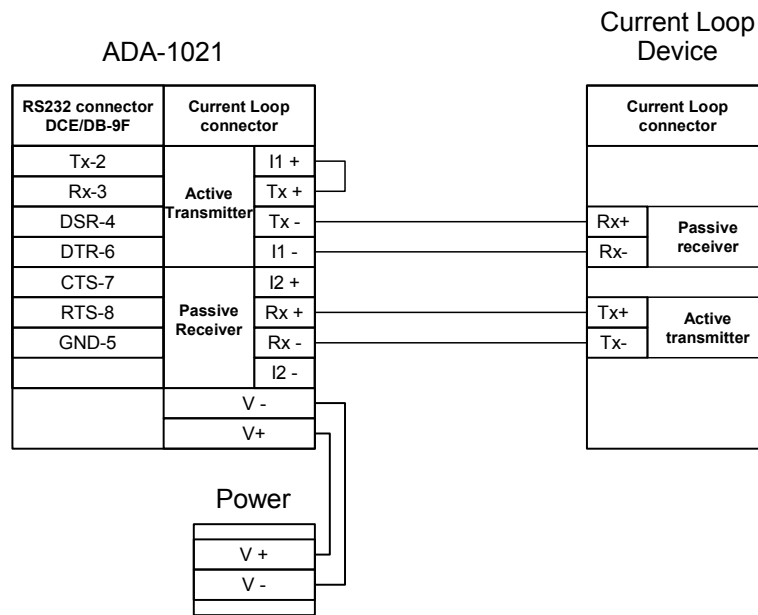

Fig. 9. Example connection of device with active transmitter and passive receiver to ADA-4021

**3.3.4. CONNECTION TO DEVICE WITH PASSIVE TRANSMITTER & ACTIVE RECEIVER**

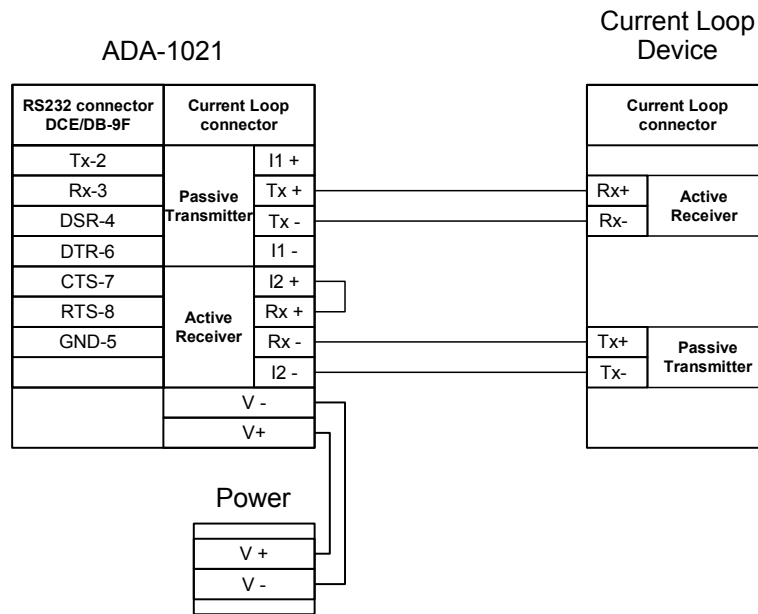

Fig. 10. Example connection of device with passive transmitter and active receiver to ADA-4021



**3.4. CONNECTION TO COMPUTER**

**3.4.1. EXTENSION OF RS232 PORT OF PC**

By using the ADA-1021 can be separated RS232 PC port from operating devices and extend it (TX, RX signals) at a distance up to several hundred meters. The connection is shown below.

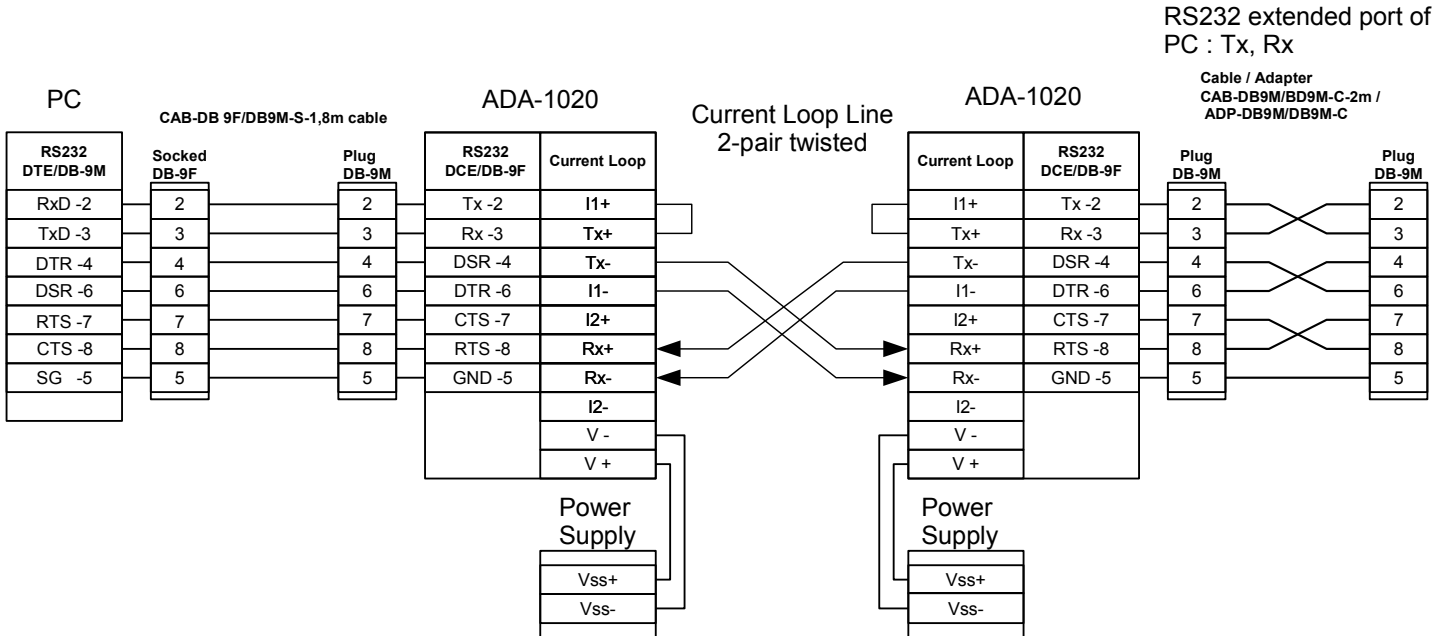

Fig. 11. Connection of ADA-1021 for operating as extension of RS232 PC port

**3.4.2. EXAMPLE CONNECTION OF CNC MACHINE CT40-CNC CONTROLEPL1 TO PC**

By using the ADA-1021 can be connected to PC eg. CNC machine CT40-CNC CONTROLEPL1. The connection is shown below.

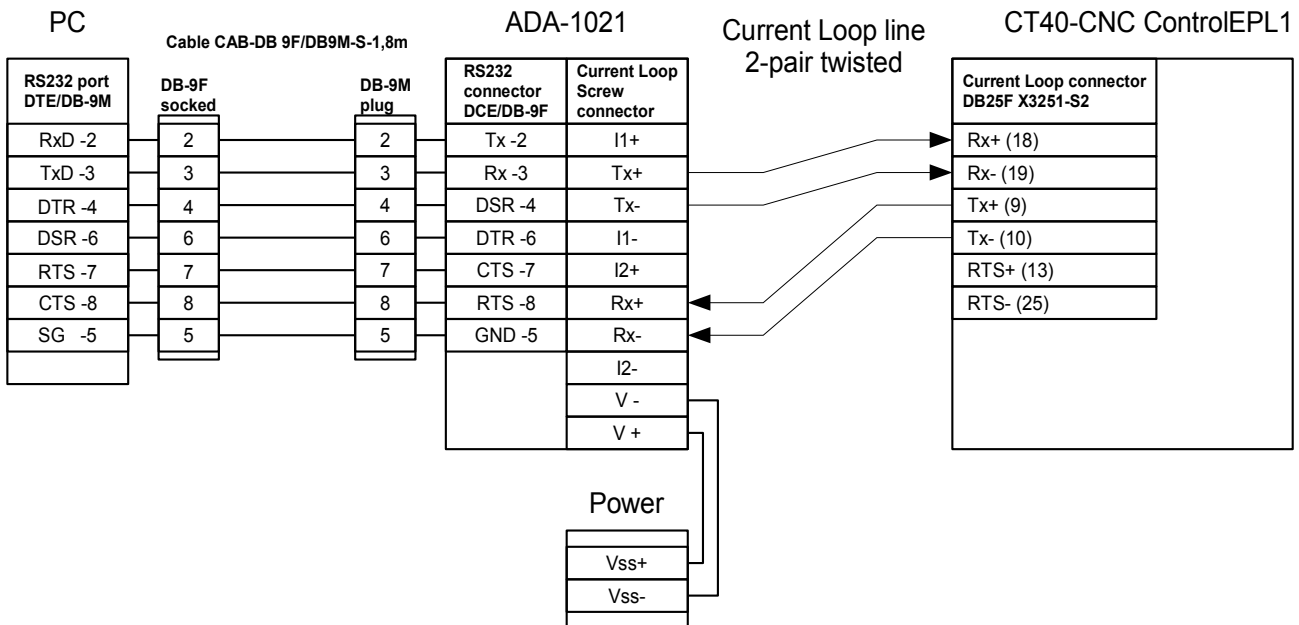

Fig. 12. Example connection of CNC machine CT40-CNC CONTROLEPL1 to PC by the use of ADA-1021

**3.5. POWER SUPPLY CONNECTION**

The power supply to the ADA-1021 converter should be DC (regulated) from 10 V= to 30V=. Nominal power is typically 2W, e.g. ZS-12/250 or DR-15-24. Power cable from DC power supplies to device must not be longer than 3m. Observe the polarity, connect positive (+) of DC power supplies to V+ and negative (-) end to V- terminal. ADA-1021 has the protection from opposite connection power supply. If after powering on the front panel is not lit green LED PWR, check the correctness of power connection (polarity).

**4. ACTIVATION**

Converter can be powered after proper connection according to steps above. If the connection was made properly green LED PWR on front panel of converter should lit, if not check polarization of power connection. If the red LED RX is lit check correctness of connection transmitting line of Current Loop Device. The lighting of RX LED indicates no current flow through the optocoupler in the receiver's circuit. During proper data transmission through converter the LEDs Tx and Rx should blink.

**4.1. LEDS DESCRIPTION**

LED	Description
PWR	Signalization of power supply
RX	Signalization of data receiving by ADA-1021 from Current Loop.
TX	Signalization of data transmission from ADA-1021 converter through Current Loop

**ATTENTION!**  
**AT BAUD RATE ABOVE 38.4 KBPS THE LED'S TX, RX WILL LIT WEAKLY DURING DATA TRANSMISSION**

**5. RS232 INTERFACE – PIN DESCRIPTION OF DSUB-9F-DCE SOCKET**

Pin	Signal	Description	ADA-1021
1	(DCD)	Level of receiver signal	Connected with DSR
2	(TxD)	Data transmission from ADA-1021	Transmitter
3	(RxD)	Data receiving from ADA-1021	Receiver
4	(DSR)	Device readiness of data receiving/ transmission	Connected with DTR
5	(SG)	Signal ground	GND
6	(DTR)	ADA-1021 readiness of data receiving/ transmission	Connected with DSR
7	(CTS)	The device confirms acceptance of the signal RTS from ADA-1021	Connected with RTS
8	(RTS)	ADA-1021 notify to the device readiness receiving data	Connected with CTS
9	(RI)	Call rate	Not connected

**6. VERSIONS**

	ADA-1021 -	-	
<b>Current Loop type:</b>			
24VDC / 20mA – active/passive transmitter, receiver		<b>1</b>	
12VDC / 20mA (TTY) - active/passive transmitter, receiver. Standard version		<b>2</b>	
<b>3-way galvanic isolation:</b>			
1kV=			<b>2</b>
3kV=			<b>3</b>

Order example:  
Product Symbol: **ADA-1021-1-2**  
**1** – 24VDC/20mA Current Loop type  
**2** – 1kV=, 3-way galvanic isolation.

Product Symbol: **ADA-1021-2-3**  
**2** – 12VDC/20mA Current Loop type  
**3** – 3kV=, 3-way galvanic isolation.

## 7. SPECIFICATION

<b>Transition Parameters</b>		
	<b>RS-232</b>	<b>Current Loop</b>
<b>Connector</b>	DSUB-9 female	Screw terminal, wire max. Ø 2,5mm <sup>2</sup> .
<b>Line length</b>	15m	Depend on baud rate eg. For bus made by UTP cable Cat.5E 4x2x0,5 (24 AWG) and baud rate 19200 bit/s the line length up to 1000m.
<b>Maximum number of connected device</b>	1	1
<b>Transmission line</b>	DB9F/DB9M multicore cable 9x0,34 shielded (up to 15m) or 9-pair twisted cable, UTP 9x2x0,5 (24AWG) shield inside large interferences STP 9x2x0,5 (24AWG).	2-pair twisted cable eg UTP Nx2x0,5 (24AWG), shield inside large interferences eg STP Nx2x0,5 (24AWG).
<b>Standards</b>	RS-232C /CCITT.V.24	current signal, 0-20mA
<b>Maximum baud rate</b>	38,4 kbps (depend on length of Current Loop line)	
<b>Transmission type</b>	Current Loop asynchronous half duplex or full duplex	
<b>Optical signalization</b>	<ul style="list-style-type: none"> <li>• PWR – green LED power supply,</li> <li>• RX - red LED data receiving from Current Loop side,</li> <li>• TX - yellow LED data transmission through Current Loop interface.</li> </ul>	
<b>Nominal work conditions</b>		
<b>Power requirements</b>	Standard : 10 - 24 – 30 V DC	
<b>Power cable</b>	Recommended length of power cable < 3m	
<b>Power</b>	<3W	
<b>Protection from reverse power polarization</b>	YES	
<b>Galvanic isolation</b>	1kV= or 3kV= ( between power circuit and RS-232 signal line) 1kV= or 3kV= (between power circuit and Current Loop signal line)	
<b>Optoisolation</b>	~3kV= (between signal lines Current Loop and RS-232)	
<b>Operating temperature</b>	0 ÷ +23 ÷ +50 °C	
<b>Humidity</b>	5 ÷ 95% - non-condensing	
<b>Installation during operation</b>	Free	
<b>Mounting</b>	Rail mounting according to DIN35 standard / TS35.	
<b>Electromagnetic compatibility</b>	Resistance to disruptions according to the standard PN-EN 55024. Emission of disruptions according to the standard PN-EN 55022.	
<b>Safety requiring</b>	According to the PN-EN60950 norm.	
<b>Environment</b>	Commercial and light industrial.	
<b>Casing</b>		
<b>Dimensions</b>	53mm x 90mm x 58 mm,	
<b>Material</b>	Noryl UL. 94 V-O	
<b>Degree of casing protection</b>	IP40	
<b>Degree of terminal protection</b>	IP20	
<b>Weight</b>	0,10 kg	
<b>According to standards</b>	DIN EN50022, DIN EN43880	
<b>Storing and Transportation</b>		
<b>Storage temperature</b>	-40 ÷ +70°C	
<b>Humidity</b>	5 ÷ 95% - non-condensing	

**Dear Customer,**

Thank you for purchasing **CEL-MAR Company** products.

We hope that this user manual helped connect and start up the **ADA-1021 converter**. We also wish to inform you that we are a manufacturer of the widest selections of data communications products in the world such as: data transmission converters with interface RS232, RS485, RS422, USB, Current Loop, Fibre-Optic Converters and Ethernet or Wi-Fi.

Please contact us to tell how you like our products and how we can satisfy you present and future expectation.

**CEL-MAR sp.j.**

Zakład Informatyki i Elektroniki  
Sciegiennego 219C str.  
25-116 Kielce, POLAND

Tel.....: +48 41 362-12-46  
Tel/fax.....: +48 41 361-07-70  
Web.....: <http://www.cel-mar.pl/en>  
Office.....: [office@cel-mar.pl](mailto:office@cel-mar.pl)  
Sales department.....: [handlowy@cel-mar.pl](mailto:handlowy@cel-mar.pl)  
Technical information .....: [support@cel-mar.pl](mailto:support@cel-mar.pl)