

# USER's Manual

## CLINOTRONIC 2000



<b>CONTENT</b>	<b>PAGE</b>
<b>1. INTRODUCTION</b>	<b>5</b>
1.1. DESCRIPTION OF THE CLINO 2000	5
1.2. STARTING	5
1.3. POSSIBLE CONFIGURATION	6
<b>2. STARTING / HOW TO USE THE INSTRUMENT</b>	<b>7</b>
2.1. DESCRIPTION OF PANEL FUNCTIONS	7
2.2. KEY FUNCTIONS	8
<b>3. HOW TO USE THE CLINO 2000</b>	<b>11</b>
3.1. CHECKING THE FUNCTIONS	11
3.2. ZERO-SETTING / ZERO ABSOLUTE AND ZERO VIRTUAL	12
3.3. SELECTING THE MEASURING UNIT	16
3.4. HOLD-FUNCTION	17
3.5. FUNCTION SEND (PRINT-FUNCTION)	18
3.6. TERMINATING A MEASUREMENT OR A SET UP	21
3.7. SELECTING A SENSOR OR AN INSTRUMENT	21
3.8. SELECTING CORRECT FILTER TYPE FOR VARIOUS APPLICATIONS	21
3.9. ABSOLUTE MEASUREMENT / RELATIVE MEASUREMENT	22
3.10. MEASURING BY SETTING LIMITS	24
3.11. DIFFERENTIAL MEASUREMENT WITH TWO CLINO 2000	25
<b>4. ERROR MESSAGES</b>	<b>27</b>
<b>5. SERVICE</b>	<b>27</b>
5.1. GENERAL	27
5.2. STORAGE	27
5.3. SPARE PARTS	27
5.4. CHANGING OF SENSOR ADDRESS	27
5.5. CALIBRATION	29
<b>6. TECHNICAL DATA</b>	<b>33</b>

### **Modifications:**

Datum / Date	Geändert durch Modified by	Beschreibung der Änderung Description of modifications
7 <sup>th</sup> of July 2000	HEH	New chapter "3.11. Differential measurement with two CLINO 2000"
24 <sup>th</sup> of Sept 2001	HEH	Units page 14 modified
8 <sup>th</sup> of Jan. 2003	HEH/MO	Index included

## INDEX

Key word		Chapter	Page
	<b>A</b>		
Absolute measurement		3.9.1	22
Absolute measurement / Relative measurement		3.9	22
Absolute measurement / Relative measurement		3.9	22
Automatic shut off deactivating		2.2.1	8
	<b>B</b>		
Battery display "BATT"		2.2.2	10
Battery lifetime		6	33
	<b>C</b>		
Calibration		5.5	29
Calibration		5.5	29
Calibration		6	33
Calibration principle		5.5.2	30
Cancelling any task		2.2.1	8
Changing of sensor address		5.4	27
Checking the functions		3.1	11
	<b>D</b>		
Data format of transmission		3.5	18
Description of panel functions		2.1	7
Description of the CLINO 2000		1.1	5
Description of the individual keys		2.2.1	8
Description of the panel		2.2.2	10
Differential measurement with two CLINO 2000		3.11	25
Differential-, resp. reference measurement with two CLINO 2000		3.11	25
	<b>E</b>		
ENTER-Key		2.2.1	8
Error messages		4.	27
Error messages		4.	27
	<b>F</b>		
Filter, selection		3.7	21
Fine calibration over the whole measuring range		5.5.2	30
Function SEND (Print-Function)		3.5	18
	<b>G</b>		
General		5.1	27
	<b>H</b>		
HOLD key		2.2.1	9
HOLD-Function		3.4	17
How to use the CLINO 2000		3.	11
Hyper terminal program		3.5	19
	<b>I</b>		
Indicator of inclination direction		2.2.2	10
Introduction		1.	5
	<b>K</b>		
Key functions		2.2	8
	<b>L</b>		
Limits		3.10	24
Limits of error		6	33
LIMITS, measuring with		3.10	24
	<b>M</b>		
Manual set-up of the virtual ZERO		3.2.2	13
Measuring by setting limits		3.10	24
Measuring units		2.2.2	10
Measuring units		3.3	16
	<b>O</b>		
ON/MODE - key		2.2.1	8

	<b>P</b>		
Panel and display		2.11	7
Possible configuration		1.3	6
Power supply, external		6	33
	<b>Q</b>		
Quick calibration		5.5.1	29
	<b>R</b>		
Reference, resp. differential measurement with two CLINO 2000		3.11	25
REL zero offset		2.2.1	8
Relative base length, measurement		3.3	16
Relative measurement		3.5.2	22
Relative measurement / absolute measurement		3.9	22
Reset		3.1	11
Resolution		6	33
Reversal measurement		3.2.1	12
	<b>S</b>		
Selecting a sensor or an instrument		3.7	21
Selecting correct filter type for various applications		3.8	21
Selecting the measuring unit		3.3	16
Selection pointer		2.2.2	10
SEND/ESC key		2.2.1	8
Sensor / instrument, selection		3.7	21
Sensor / Port A-B		2.2.2	10
Sensor address		2.2.2	10
Sensor address changing		5.4	27
Service		5.	27
Service		5	27
Settling time		6	33
Shutting off the instrument		2.2.1	8
Spare parts		5.3	27
Spare parts		5.3	27
Starting		1.2	5
Starting / How to use the instrument		2.	7
Storage		5.2	27
Storage		5.2	27
	<b>T</b>		
Technical data		6.	33
Technical data		6	33
Temperature range		6	33
Terminating a measurement or a set up		3.6	21
Terminating a measurement or a set up		3.6	21
	<b>V</b>		
Virtual zero, automatic set-up		3.2.2	14
	<b>Z</b>		
ZERO absolute (with reversal measurement)		3.2	12
Zero offset		2.2.1	8
ZERO VIRTUAL		3.2	12
ZERO VIRTUAL		3.2.2	13
ZERO/SEL "+/-" key		2.2.1	9
ZERO-Setting / ZERO absolute and ZERO virtual		3.2	12
ZEROTRONIC sensor		5.4	28

## 1. INTRODUCTION

### 1.1. DESCRIPTION OF THE CLINO 2000

The CLINO 2000 was developed by WYLER AG as an intelligent display and measuring unit together with the digital instrument's family ZEROTRONIC. With this instruments all the sensors and instruments of the ZEROTRONIC family can be used (See point 1.3 Configuration)

The CLINO 2000 is a

- Measuring instrument
- Display unit

On the CLINO 2000 a number of parameters can be changed and adjusted:

- Measuring unit
- Measuring mode
- Relative base length                      and many more

The CLINO 2000 is compatible with the other instruments of the ZEROTRONIC family by using the RS485 serial communication. The measuring values may be transmitted to a printer or a PC/Laptop via RS232 output.

The measuring principle of the ZEROTRONIC family is based on a changing of the capacity of a condenser built of two electrodes and a pendulum in form of a shield installed in between. The measured change of capacity is directly influenced by the change of the inclination of the pendulum. This capacity change is the primarily used signal for the angle to be measured. The measuring system is designed to be completely antimagnetic. The basic signal received in the CLINO 2000 will be computed into an angle by comparing the signal with a reference curve stored and then displayed in the required unit.

### 1.2. STARTING

Before working with the CLINO 2000 it is strongly recommended to carefully read this manual first.

This will avoid malfunctioning by making unsuitable manipulations like e.g. deleting the calibration data in the sensor head etc.

### 1.3. POSSIBLE CONFIGURATION



Stand alone unit

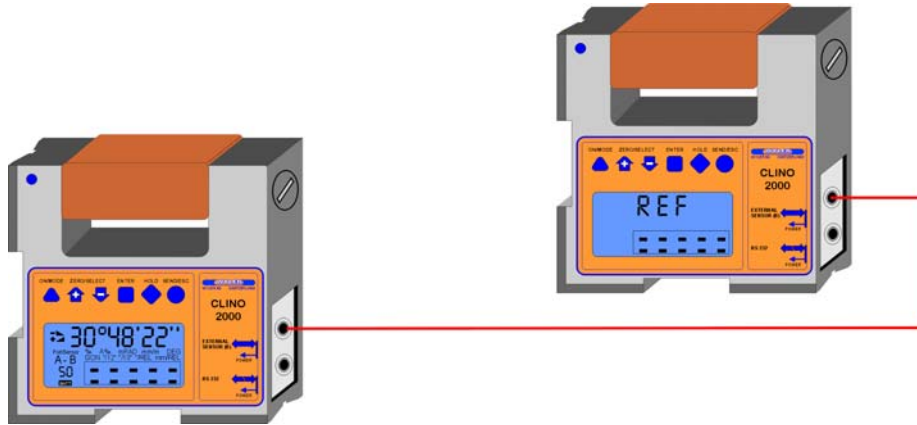

Two units connected for remote display or differential mode / max. 15m

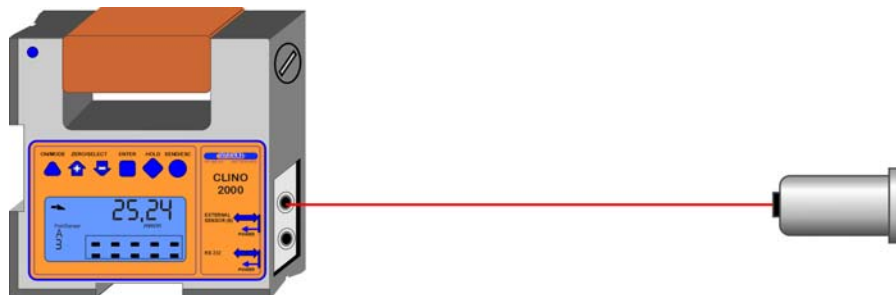

CLINO 2000 connected with ZEROTRONIC Sensor / max. 15m

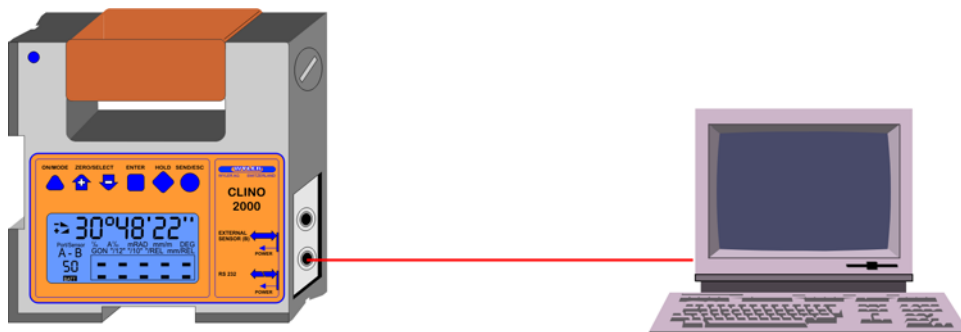

CLINO 2000 connected to a PC / RS232

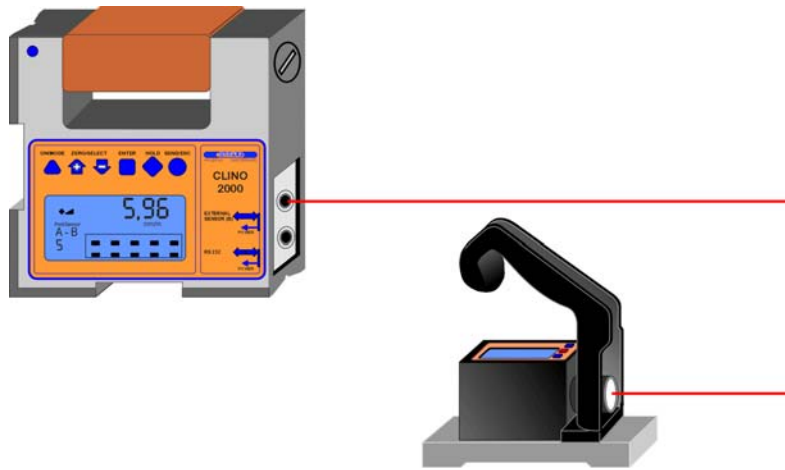

**CLINO 2000 connected with a MINILEVEL or LEVELTRONIC „NT“ for differential mode**

All the above configurations can be used. For specifications of the sensors and the instruments see the respective data sheets.

## 2. STARTING / HOW TO USE THE INSTRUMENT

### 2.1. DESCRIPTION OF PANEL FUNCTIONS

#### 2.1.1. PANEL AND DISPLAY

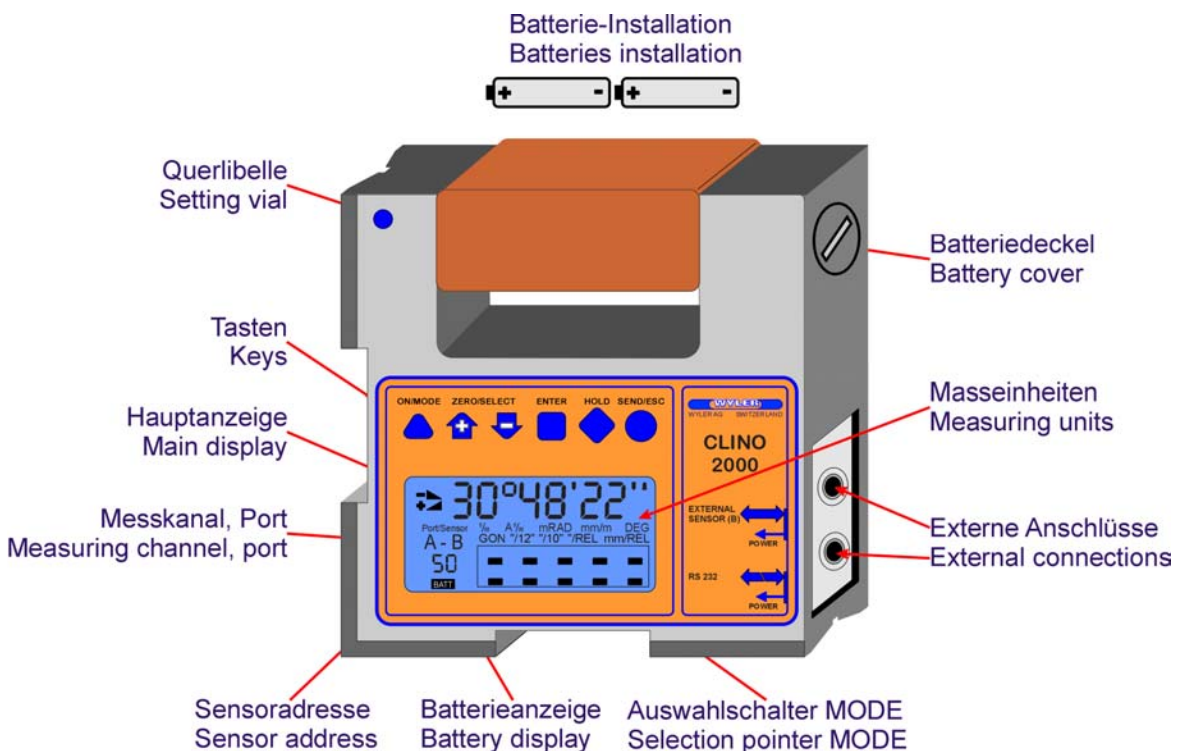

## 2.2. KEY FUNCTIONS

### 2.2.1. DESCRIPTION OF THE INDIVIDUAL KEYS



#### ON/MODE - Key

**Function - 1 -** Pressing the ▲ **ON/MODE** key starts the CLINO 2000. When keeping the key pressed all the LCD elements are lighted. After releasing the key the instrument switches to the measuring mode and the calibration data of the internal sensor has been collected. After a short period of time the actual angle will be displayed in the last used measuring unit. In case of trouble an error message will be displayed. (See point 4)

When pressing the ▲ **ON/MODE** key for more than 3 seconds the display starts flashing and **the automatic shut off is disabled**. In the standard mode the instrument shut off after about 5 minutes. To turn off the instrument press the ▲ **ON/MODE** key for more than 3 seconds until the display disappears.

**Exception:** In case the instrument is powered by an external power supply, the instrument is never shutting off automatically.

**Function - 2 -** The ▲ **ON/MODE** is also used for moving the selection pointer on the lower display area. By pressing this key the selection pointer moves from one position to the next.

**Function - 3 -** For shutting off the CLINO 2000; the ▲ **ON/MODE** key needs to be pressed for 3-4 seconds until the displayed figures disappear.

**Function - 4 -** Used for „ZERO-Setting“ of saved (memory) values in the function „REL ZERO“. To set the memory in this function to ZERO press the ▲ **ON/MODE** key, the displayed values will become ZERO. This has to be confirmed by pressing ■ **ENTER**



#### ENTER – Key

The key ■ **ENTER** is used to save an entered value or to accept a selected function.



#### SEND/ESC- Key

**Function - 1 -** The key ● **SEND** is used for the transmission of a measuring value through the RS232 port or to send the value to a printer or another connected system. Through the same port the values may also be transmitted to a PC or Laptop for further treatment of the data.

**Function - 2 -** Also used for canceling any „HOLD“ function and return to the measuring mode.

**Function - 3 -** Canceling any task not yet finished.





## ZERO/SELECT "+/-" - Key

The key **ZERO "+/-"** can be used to change a number of possible parameters like e.g.

- Measuring units
- Measuring units, respectively ports ( „A“ / „B“ / „A+B“ / „A B“ )
- Changing of the measuring range
- Changing of the instruments address
- Set up the relative base length
- Set up of the „Zero-Offset“
- Set up of the „REL Zero-Offset“ etc.



## HOLD - Key



### Function - 1 -

With the **HOLD** key a measured value may „frozen“. This value will be displayed until by pressing the key **SEND** the CLINO 2000 will return to the measuring mode.

### Function - 2 -

When using the mode REL ZERO and ZERO the actual measuring value can be accepted by pressing the **HOLD** key

## 2.2.2. DESCRIPTION OF THE PANEL

<b>Main display</b>	The actual measuring values of an active sensor/instrument are displayed. By using the mode „SENSOR“ other sensors or instruments connected at port B may be selected, differential measurement may be applied.	
<b>Indicator of inclination direction</b>	The pictograph indicates the direction of the inclination	
		declining to the right (negative angle)
		inclining to the right (positive angle)
<b>Selection pointer</b>	With the selection pointer the intended function can be chosen:	
	<b>SENSOR</b>	Select the active sensor/port
	<b>ABSOLUTE</b>	Absolute measuring mode
	<b>REL ZERO</b>	Relative measuring mode
	<b>UNIT</b>	Selection of measuring units
	<b>ZERO</b>	Set absolute zero
	<b>LIMITS</b>	Output of control signals
	<b>FILTER</b>	Adjustment of filter type
	<b>ADDRESS</b>	Display and changing of sensor addresses
	<b>CALIB</b>	Calibration of sensors
	<b>ONLINE</b>	Display of active communication through port
<b>Battery display "BATT"</b>	When the battery power is low, the sign "BATT" is constantly on	
<b>Measuring units</b>	The actual measuring unit is displayed. 10 basic units are available and most of them can in addition be changed into subunits.	
<b>Sensor/port A-B</b>	<b>Function - 1 -</b>	The connection/port is displayed for information concerning: - the displayed measuring value - active sensor/instrument for calibration purposes
	<b>Function - 2 -</b>	Shows the measuring mode e.g. individual measuring or differential measuring (A-B)
<b>Sensor address</b>	The active sensor address is displayed	

### 3. HOW TO USE THE CLINO 2000

#### 3.1. CHECKING THE FUNCTIONS

The key **▲ ON/MODE** can be pressed. As long as this key is pressed all elements of the LCD display will show up. After releasing the key the mode is switched to the measuring mode. The active signal is displayed in the last used measuring unit. During the reading of the calibration data six small „o“ will be displayed.

The following display variations are correct:

-▶ 20.834	-20,834 degrees
+▶ 4°40'23''	+4°40'23''
+▶ O U E R	OVER (Over Range)
o o o o o o	Levelmeter busy

When now the connected instrument or sensor is tilted, the displayed value must change accordingly.

If a second instrument or an additional sensor has been connected to port B, a respective message may appear if some errors are noted:

The following error messages are possible:

<b>ERROR 0</b>	Instrument is defect, to <b>be sent to the service center</b>
<b>ERROR 1</b>	No sensor or instrument connected, or not properly installed
<b>ERROR 2</b>	No measurement has been done so far with the connected sensor/instrument. The sensor must be addressed correctly (See point 3.7. Selecting a sensor or an instrument)
<b>ERROR 3</b>	Calibration data not available. The display shows the malfunctioning item (port and address) also possible when the battery power is not sufficient (Communication with sensor not possible)

**For other error messages see point 4**

To reinstall the basic set up a RESET may be done at any time. The procedure is as follows:

Both keys **▲ ON/MODE** and **■ ENTER** must be pressed simultaneously for at least one second. All the manually installed data is lost and the CLINO 2000 will be set to the following basic standards:

Basic standards:	
Measuring mode:	absolute
Measuring unit:	the next possible and useful unit
Relative Base:	1000 mm
ZERO-OFFSET absolute:	remains intact
Sensor:	PORT A, no Sensor (ERROR 2)
Filter	No 5

Immediately after RESET the error message 2 is displayed. This means the connected sensor must be addressed correctly from new. (See point 3.7. Selecting a sensor or an instrument)

### 3.2. ZERO-SETTING / ZERO ABSOLUTE AND ZERO VIRTUAL

**Remarks:**

Using ZERO SETTING two different tasks can be realized:

- a) **ZERO ABSOLUTE** / The instrument shows "0" when the angle of the mounting surface is exactly positioned in the direction of the center of the earth.
- b) **ZERO VIRTUAL** / The instrument shows "0" at any predefined angle.

#### 3.2.1. ZERO ABSOLUTE (WITH REVERSAL MEASUREMENT)

The ZERO absolute is the basis for all the inclination measurements in the absolute mode. For such a measurement if high precision is required, it is of utmost importance that the object to be measured and the CLINO 2000 are both at the same temperature level. The CLINO 2000 should have been turned on a few minutes before the measurement procedure. For this procedure a suitable surface must be chosen (rigid, flat and as horizontal as possible). On this surface the CLINO 2000 must be placed; the exact position of the instrument is to be marked on the surface.

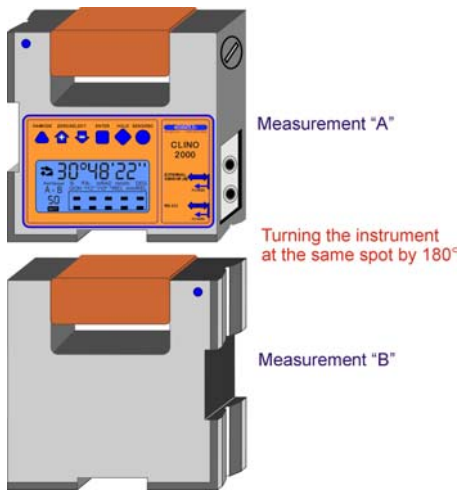

The ZERO absolute will automatically be set by applying the reversal measurement. (Taking two measurements on the same spot but in the 180° opposite direction) For this procedure a suitable surface must be chosen (rigid, flat and as horizontal as possible). On this surface the CLINO 2000 must be placed, the exact position of the instrument is to be marked on the surface.

$$\text{ZERO OFFSET} = \frac{\text{Measurement "A"} + \text{Measurement "B"}}{2}$$

**The „ZERO-OFFSET“ is stored in the CLINO 2000**

**EXAMPLE:**

The selection pointer of the CLINO 2000 must now be placed below the marking ZERO by pressing the ▲ **ON/MODE** key several times. If the required position is reached, it must be confirmed by pressing the ■ **ENTER**. On the display the last set „Zero-Offset“ (Basic offset) will be displayed. The direction indicator (+/-) is flashing. □

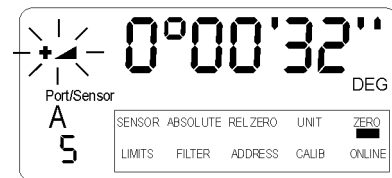

The CLINO 2000 must now sit at position one and after a few seconds settling time allowed, by pressing the key ◆ **HOLD**, the first reading is collected. This first value is displayed and the selection pointer below ZERO is flashing which means the second reading is expected.



The CLINO 2000 must now be rotated horizontally by 180° and placed exactly on the same spot. After a few seconds settling time the key ◆ **HOLD** must be pressed again for collecting the second reading. □

The computed „Zero-Offset“ (Basic offset) is now displayed on the CLINO 2000.

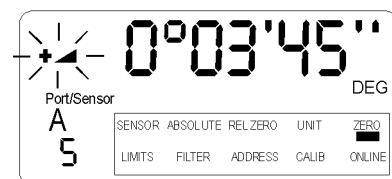

(The displayed „Zero-Offset“ is calculated by adding the two readings and dividing the result by two.) □

If this „Zero-Offset“ (Basic offset) must now be saved, the key **ENTER** must be pressed. Immediately after this, the selection pointer jumps to the measuring mode absolute and the measuring result under consideration of the „Zero-Offset“ (Basic offset) will be displayed.

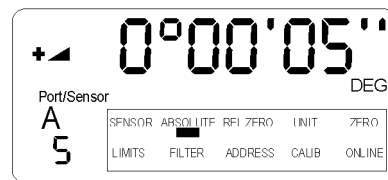

The „Zero-Offset“ (Basic offset) computed by applying the reversal method is the deviation of the instrument's ZERO to the absolute ZERO. The display on the CLINO 2000 therefore is the:

**Displayed value =**  
**Value of the CLINO 2000 minus „Zero-Offset“.**

The reversal measurement to establish the exact „Zero-Offset“ (Basic offset) should be done periodically if high quality measurements are required. Especially after longer intervals the method is useful.

### 3.2.2. ZERO VIRTUAL

#### 1) Manual set-up of the virtual ZERO

One possibility of using ZERO virtual means to establish an artificial plane, respectively angle, to be chosen as absolute zero.

Another possibility is to change the existing „Zero-Offset“ (Basic offset) of the CLINO 2000 e.g. established by means of using the reversal method.

**Only well skilled and trained user should make use of this feature!!!**

**Example:**

#### Initial position:

The display on the CLINO 2000 shows the measured value of +0°07'20". This value is the true inclination of the instrument.

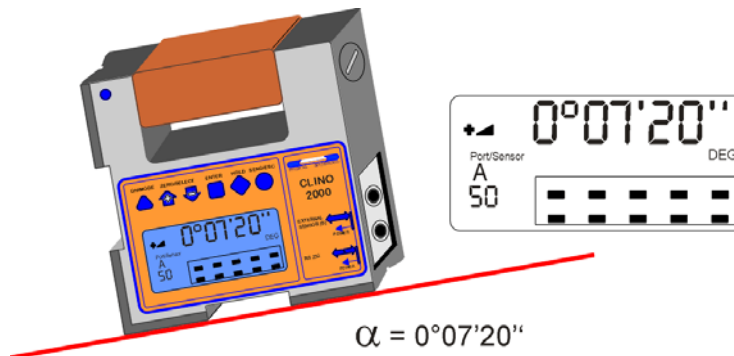

Only one sensor (internal sensor of the CLINO 2000 or the external sensor connected to Port "B") at a time can be set to ZERO virtual. This sensor must be selected first.

The selection pointer must be moved below the marking ZERO in the display of the CLINO 2000 by pressing the key **ON/MODE** several times. If reached the selection must be confirmed by pressing **ENTER**.

The last computed or manually entered value „Zero-Offset“ (Basic offset) is displayed. In our example 00° 00' 00"

The direction indicator is flashing

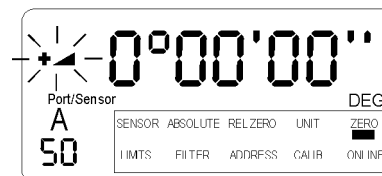

This displayed value may now be changed manually by applying the keys **ZERO/SELECT** „+/-“ to the desired value.

e.g. from +0° 00' 00" to new +0°07'20"

The direction indicator is flashing

The value is now the new „Zero-Offset“



If this so manually established „Zero-Offset“ must now be saved the key **ENTER** must be pressed. The new „Zero-Offset“ is now saved in the CLINO 2000. Immediately after this, the selection pointer jumps to the measuring mode absolute and the measuring result under consideration of the new „Zero-Offset“ will be displayed. The following new value will now be displayed in the absolute mode:

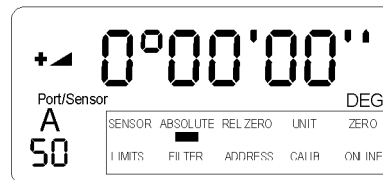

**„ZERO-OFFSET“ is stored in the CLINO 2000**

**Displayed value =  
Value of the CLINO 2000 minus „Zero-Offset“.**

**Remarks:** Until the input is confirmed by using the **ENTER** key, every manipulation can be stopped any time by pressing **SEND/ESC**

**Result:**

Despite the fact that CLINO 2000 is still placed at the same angle the display of the instrument now shows the value 0°00'00''. This is the so called virtual ZERO

This new virtual ZERO is the reference for all the future measurements based on this angle (originally 0°07'20'')

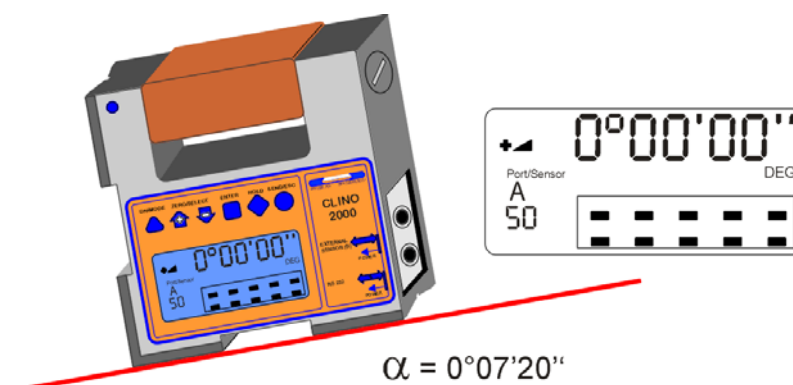

**II) Automatic set-up of the virtual ZERO**

Practically quite often a measuring surface is not absolutely horizontal but should be the reference plane for other measurements. In these cases it is useful to set the basic value for this surface to: 0°00'00''. This can be done by manually setting the virtual zero as described before or by automatically define the value with the CLINO 2000 set-up. (It is done by using a reversal measurement mode without turning the instrument 180 deg.)

**Procedure:**

**Initial position:**

The display shows the measured value on the CLINO 2000 : +0°09'16''. This value is the true inclination of the CLINO 2000.

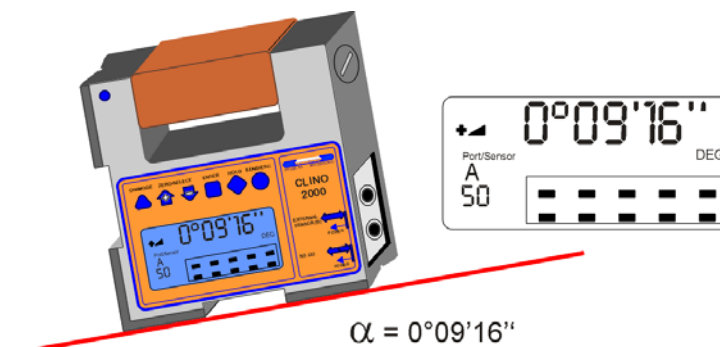

The selection pointer must be moved below the marking ZERO in the display of the CLINO 2000 by pressing the key **ON/MODE** several times. If reached the selection must be confirmed by pressing **ENTER**.

The last computed or manually entered value „Zero-Offset“. The direction indicator is flashing

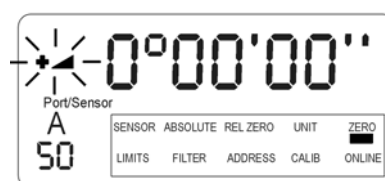

The CLINO 2000 must now sit at position one and after a few seconds settling time allowed, by pressing the key **HOLD**, the first reading is collected. This first value is displayed and the selection pointer below ZERO is flashing which means the second reading is expected.



After a few seconds settling time the key **HOLD** must be pressed again for collecting the second reading. The instrument remains at the same position without turning 180°.

The newly computed „Zero-Offset“ is now displayed on the CLINO 2000

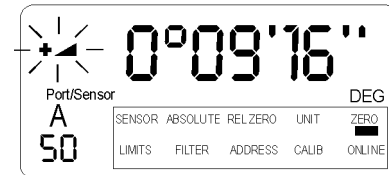

(The displayed „Zero-Offset“ is calculated by adding the two readings and dividing the result by two.)

If this „Zero-Offset“ must now be saved, the key **ENTER** must be pressed. Immediately after this, the selection pointer jumps to the measuring mode absolute and the measuring result under consideration of the „Zero-Offset“ (Basic offset) will be displayed.

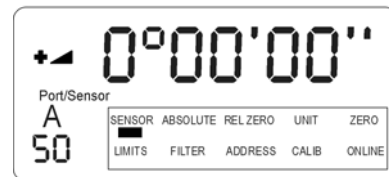

**The „ZERO-OFFSET“ is stored in the CLINO 2000**

**Displayed value =  
Value of the CLINO 2000 minus „Zero-Offset“.**

**Remarks:** Until the input is confirmed by using the **ENTER** key, every manipulation can be stopped at any time by pressing **SEND/ESC**

**Result:**

Despite the fact that the CLINO 2000 is still placed at the same angle the display of the instrument now shows the value 0°00'00" This is the so called **virtual ZERO**

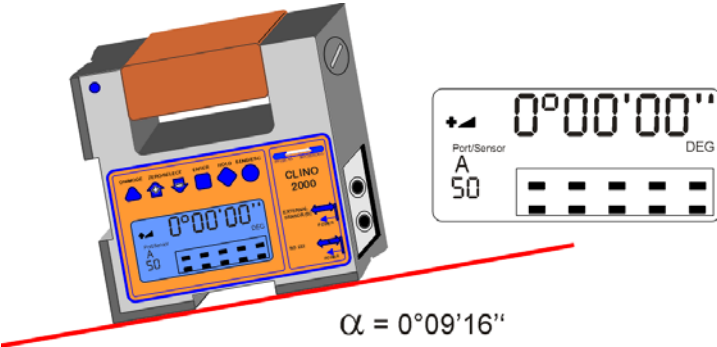

This new virtual ZERO is the reference for all the future measurements based on this angle (originally 0°09'16")

**Remarks:** Please see also "Relative measurement" Chapter 3.9.2

### 3.3. SELECTION OF THE MEASURING UNIT

The desired measuring unit can be selected by repeatedly pressing the key **▲ ON/MODE** until the selection pointer is below the function **UNIT** and then the **■ ENTER** is pressed.

The possible formats may now be chosen by pressing the key **⬆ ZERO/SELECT "+/-"** until the desired unit is displayed. This selection must be confirmed by pressing **■ ENTER**. The selection remains valid until changed in the same manner as described above.

The following measuring units can be chosen:

xxx° xx'	DEG	Deg / Min
xx° xx' xx"	DEG	Deg / Min / Sec
xxxx' xx"	DEG	Min / Sec
xxx.xxx°	DEG	Degree, 3 decimal
xxx.xx	‰	‰, 2 decimal
xxx.xx	A ‰	Artillerie-Promille
xx.xxxx	"/REL	mm per relative base, 4 decimal
xxx.xx	mm/REL	mm per relative base, 2 decimal
xxxx.xx	mRad	Milliradian, 2 decimal
xx.xxxx	"/12"	Inch per 12 Inch, 4 decimal
xx.xxxx	"/10"	Inch per 10 Inch, 4 decimal
xxxx.xx	mm/m	mm per m, 2 decimal
xxx.xxx	GON	New degree, 3 decimal

For a measurement with **relative base length** the selection pointer must be moved by repeatedly pressing the **▲ ON/MODE** key to the position **UNIT**. Confirm with **■ ENTER**.

By using the keys **⬆ ZERO/SELECT "+/-"** the desired unit can now be chosen (mm/REL or inch/REL) The selection must be confirmed with the key **■ ENTER**.

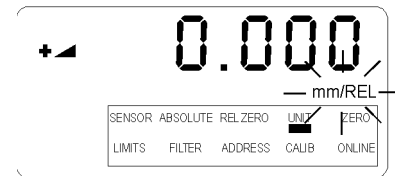

On the display the direction indicator is flashing alternatively plus or minus; the existing base length is shown (Standard length is 1000 mm or 10")

By pressing **■ ENTER** this value may be accepted or with **⬆ ZERO/SELECT "+/-"** the relative base length may be adjusted as required and then finally confirmed with **■ ENTER**.

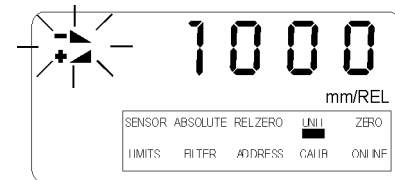

In the relative mode the angle is related to the height "X" as the elevation over the set relative base length in the chosen unit (in mm, or Inch).

**Exception:** RESET (see point 3.1)

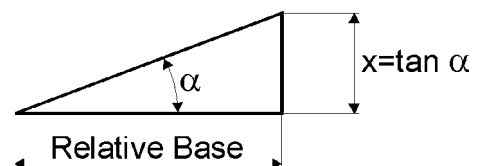



### 3.4. HOLD-FUNCTION

This function is available in all measuring modes.

Place the CLINO 2000 on a flat stable surface. Use the key **HOLD**. While the CLINO 2000 waits for a valid measurement (two identical values in succession) the display will show "ooooo". As it is practically impossible for two successive values to be identical while the instrument is handled, the instrument may be positioned after the key is depressed. □

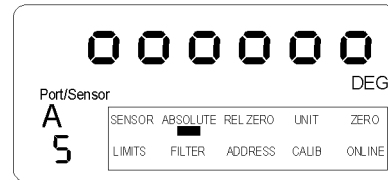

As soon as the condition for a valid measurement is fulfilled, the measuring value is displayed, the direction indicator flashing. To read the measurement value, the CLINO 2000 may be removed from its located position. The display value is "frozen".

Use the key **SEND/ESC**. If a printer is connected, the measured value will be transmitted and the CLINO 2000 will be ready for use in the normal mode. If you just want to read the value,

pressing **SEND/ESC** again will return to the standard mode. If HOLD is required for the next measurement, it is possible without canceling; directly to recall **HOLD** again.



#### Remarks:

The level of vibration at the measuring location considerably influences the time necessary to collect a valid measurement. Severe vibration may even completely prevent the condition (two identical values in succession), necessary to register a true measurement.

In order to regain measuring capability under this condition, take the instrument to an object with a lower vibration level and complete the operation in process. By key using **SEND/ESC** the further procedure may be cancelled immediately. The displayed value may now be accepted or the process must be repeated.

If after 60 seconds no value was accepted, the „**ERROR 7**“ message is displayed.

**HOLD** function has not been successfully completed within 60 seconds. The procedure needs to be repeated.

By using the function **RESET** the CLINO 2000 will return to the standard settings. With the exception of the calibration data all previous adjustments are lost!!

### 3.5. FUNCTION SEND (PRINT-FUNCTION)

Using the key **SEND/ESC** will send the displayed value through the port "RS 232" to a connected PC, or Laptop via the RS232 port. This function can also be used in combination with **HOLD** in order to transmit the „frozen“ value.

The function SEND may be activated from a connected PC/Laptop by transmitting a letter „P“ (as letter) through the serial port RS 232

#### DATA FORMAT OUT-PORT

##### Measurement active

MessMode_A	[sss Aaaa sn.nnnnnn<cr>]
MessMode_B	[sss Baaa sn.nnnnnn<cr>]
MessMode_A_minusB	[sss Aaaa-Baaa sn.nnnnnn<cr>]
MessMode_A_B	[sss Aaaa sn.nnnnnn Baaa sn.nnnnnn<cr>]

sss = 0 .. 255 - Continuous no.  
aaa = Sensor Address 1..255 (e.g. 004) / ML/LT NT 1-32  
sn.nnnnnn = +9.999999 - Positive Overrange  
              -9.999999 - Negative Overrange  
              other value - Angle in rad e.g. +0.226349

##### Menu active or error ( -0.000000 means no data available)

MessMode_A	[9xy Aaaa -0.000000<cr>]
MessMode_B	[9xy Baaa -0.000000<cr>]
MessMode_A_minusB	[9xy Aaaa-Baaa -0.000000<cr>]
MessMode_A_B	[9xy Aaaa -0.000000 Baaa -0.000000<cr>]

aaa = Sensor Address 1..255 resp. 0 when address undefined  
x = 0 - General error  
      1 - Port A error  
      2 - Port B error  
y = 0 - Menu active (no error)  
      >0 - Error codes (According to manual)

##### Format of transmission

asynchrony, 7Bit, 2 Stopbits, no parity

## Example using the Hyper Terminal of Windows NT or Windows Terminal program (Example is WIN NT)

1. Open the Terminal-Program in Windows / Accessories. and insert a name

Confirm with OK



2. Enter the serial port definition connected to the CLINO 2000.

Confirm with OK



3. Enter the parameters

Bits per Second:	9600
Data bits:	7
Parity:	no
Stop bits:	2
Protocol:	no

Confirm with OK

The HyperTerminal-Windows appear.

Repeatedly pressing the key  SEND/ESC the actual value will be transmitted in [Rad]

Alternatively the value can be called by pressing the key "P" on the PC keyboard.

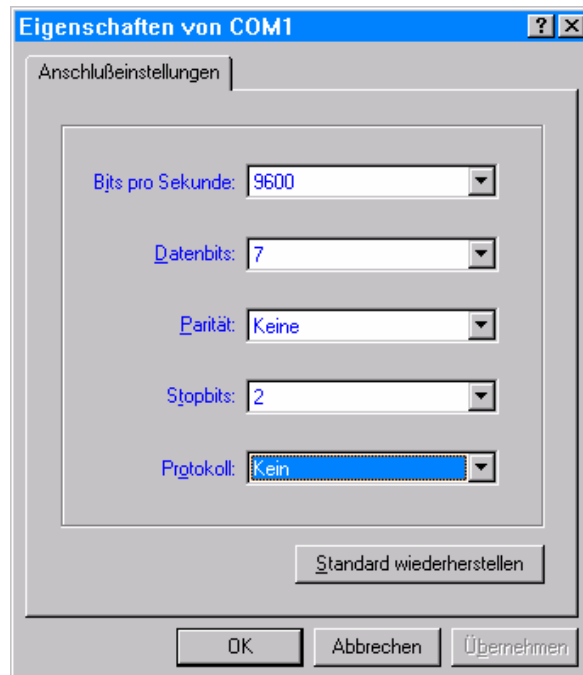

CLINO 2000 with address 50 connected to port "A"

Meaning of the display:	
<b>068</b>	Continuous number. (3 measurements per second are performed)
<b>A050</b>	Port „A“, address 50
<b>-0.000100</b>	- 0.000100 Rad resp.-100 µRad

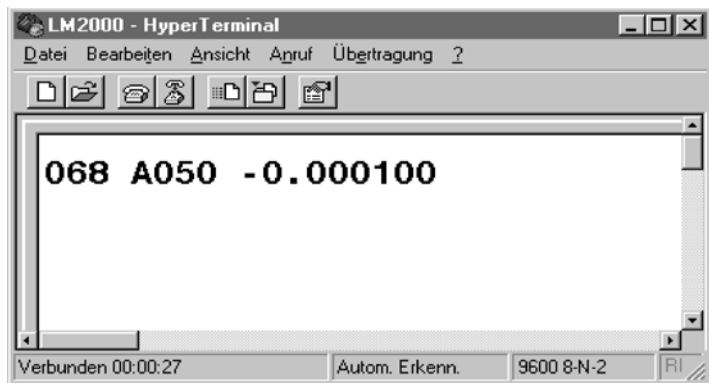

CLINO 2000 with address 50 is connected to port "A",  
one external sensor with address 21 is connected to port "B" / Measuring mode: A & B alternatively measured

Meaning of the display:	
<b>031</b>	Continuous number.
<b>A050</b>	Port „A“, address 50
<b>-0.000104</b>	- 0.000104 Rad resp.-104 µRad
<b>B021</b>	Port „B“ address 21
<b>+0.001079</b>	+0.001079 Rad resp.+1079 µRad

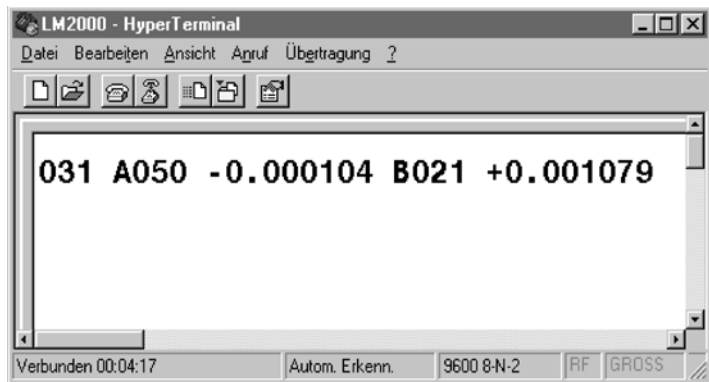

CLINO 2000 with address 50 is connected to port "A",  
one external sensor with address 21 is connected to port "B" / Measuring mode: A - B differential measurement

Meaning of the display:	
<b>141</b>	Continuous number
<b>A050 – B021</b>	Measuring mode <b>Differential mode</b> Port „A“ CLINO 2000 with address 50 minus Port „B“ sensor with address 21
<b>-0.001144</b>	Difference Sensor [A] – [B]: - 0.001144 Rad resp.-1144 µRad

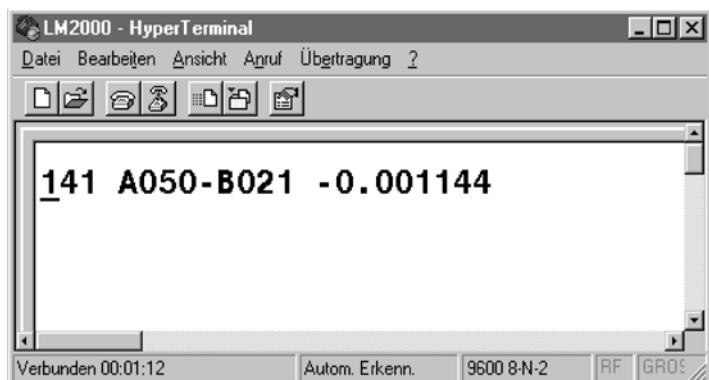

### 3.6. TERMINATING A MEASUREMENT OR A SET UP

In case of the required canceling of a measuring procedure or the changing of parameters the process may be ended at any time and the previous state will be installed by pressing **SEND/ESC**. This is true only as long as no change has been accepted by pressing **ENTER** before.

### 3.7. SELECTING A SENSOR OR AN INSTRUMENT

With the CLINO 2000 the possibility exists to display the measured values of the instrument itself as well as the difference between the instrument and an additional instrument or a connected sensor ZEROTRONIC. In case of the differential measurement the second instrument must be connected to the port B (External sensor B). It is not possible to measure the difference of two sensors connected to the same port.

Basically the following set-up is possible:

- Measurement of the CLINO 2000 (= internal sensor A, corresponding to Sensor/Port A)
- Measurement of one or more instruments connected to port B
- Differential measurement between the CLINO 2000 and another instrument at port B
- Alternating display of the CLINO 2000 and an instrument connected to port B

For differential measurement respectively measurement  
with a reference CLINOTRONIC 2000 see chapter  
**"3.11. Differential- respect. Reference Measurement with two CLINOTRONIC 2000"**

For choosing the measuring mode and the address of the sensors connected the **ON/MODE** key must be pressed repeatedly until the selection pointer is below **SENSOR** and accepted by pressing **ENTER**. The possibilities "Port A", "Port B", "Port A-B" or "Port A B" may be selected by applying the key **ZERO/SELECT "+/-"**. The desired selection can be accepted by pressing **ENTER**. After this the CLINO 2000 is looking for all the connected sensors respectively their address. Up to 255 sensors may be connected. The address of the first sensor will be displayed flashing. During the searching procedure the frame of the „Sensor address“ will flash in circular motion below the selected port.

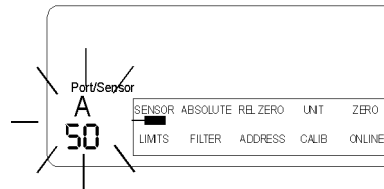

If more than one sensor is connected to the port B, the one desired can be selected by pressing **ZERO/SELECT "+/-"** and confirmed with **ENTER**.

In case of differential measurement between two sensors the same procedure must be repeated for port B.

After pressing **ENTER** the respective measurement starts.

### 3.8. SELECTING CORRECT FILTER TYPE FOR VARIOUS APPLICATIONS

A number of different types of filters are incorporated. The standard factory setting is filter type no 5. To change this setting the selection pointer must be moved below „Filter“. After pressing **ENTER** the actual setting is displayed. The number may be changed from 1 to 10 by using the + or - arrows and then be confirmed by pressing **ENTER**.

The most suitable type of filter is best found out by practically testing, as the measuring conditions have quite an influence. Generally spoken it can be said that the lowest figure (almost no filter) sends the collected signals rapidly to the display possibly resulting in an unstable display. The maximum filter (No. 10) mathematically treats the signal by collecting data and sending somewhat delayed a signal integrated over a period of time.

### 3.9. ABSOLUTE MEASUREMENT / RELATIVE MEASUREMENT

#### 3.9.1. ABSOLUTE MEASUREMENT

The standard mode (by default) is the absolute measurement.

If this is not the case when starting the CLINO 2000 the ▲ **ON/MODE** key must be pressed repeatedly until the selection pointer is in position **ABSOLUTE**. This must be confirmed with ■ **ENTER** and the **absolute mode** is ready.

The displayed value is the

**Value of the CLINO 2000 minus „ZERO - OFFSET“**

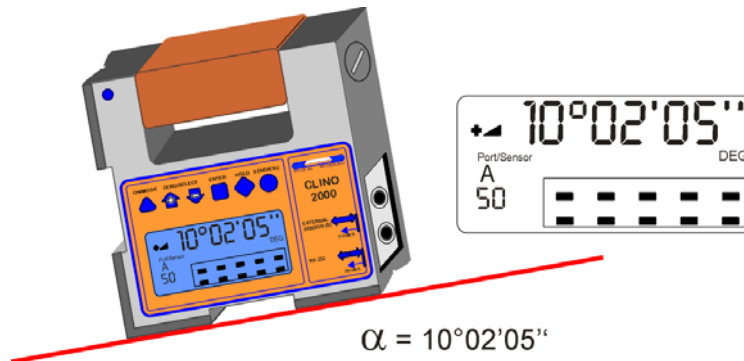

#### 3.9.2. RELATIVE MEASUREMENT

**Important remark:**

The defined „REL ZERO OFFSET“ is superimposed on the „ZERO-OFFSET“ stored in the CLINO 2000.

The „REL ZERO OFFSET“ stored temporarily in the CLINO 2000 can be recalled with any time when the same instrument is connected. This value must be confirmed or changed for example to zero.

In case of differential measurement ( 1 Sensor or instrument connected to Port A an port B each) the „REL ZERO OFFSET“ will be stored in the CLINO 2000.

**Displayed value =**

**Value of the instrument minus „ZERO-OFFSET“ minus „REL ZERO OFFSET“**

**Initial position:**

The display shows the measured value on the CLINO 2000 : +0°10'00". This value is the true inclination of the instrument.

The requirement is now to set the instrument's inclination at an angle of zero and use this angle as a reference for future measurements.

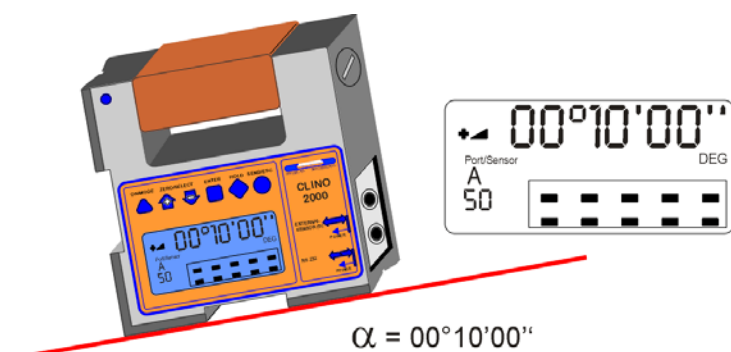

The selection pointer must be moved below the marking **REL ZERO** in the display of the CLINO 2000 by pressing the key **▲ ON/MODE** several times. If reached the selection must be confirmed by pressing **■ ENTER**.  
 The last computed or manually entered value „REL ZERO value“, in our example 0° 00'00" The direction indicator is flashing

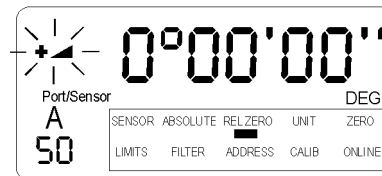

The CLINO 2000 must now be at the correct position and after a few seconds settling time allowed, by pressing the key **◆ HOLD**, the reading is collected. This value (REL ZERO OFFSET") is displayed.

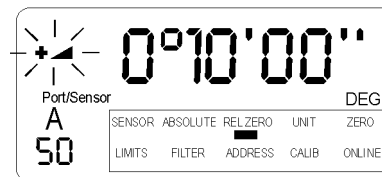

Should this value no be stored press **■ ENTER**. This relative zero value is stored in the CLINO 2000. The display jumps into the measuring mode "REL ZERO", the display is 0°00'00" and the measurement continues by considering the "REL ZERO OFFSET"

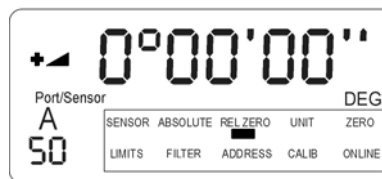

As an alternative the value can also be changed manually by using the key **▲** **▼** **ZERO/SELECT "+/-"** before confirming with **■ ENTER**

**Result:**

Despite the fact that the CLINO 2000 is still placed at the same angle the display now shows the value 0°00'00" (Fig. 1)

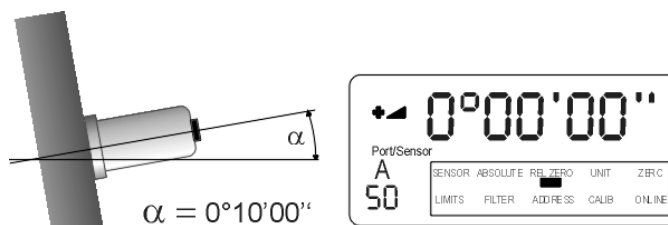

**Fig. 1**

This new relative zero is the reference for all the future measurements based on this angle (originally 0°10'00")

The selection pointer of the CLINO 2000 can now be placed below the marking **ABSOLUTE** by pressing the **▲ ON/MODE** key several times to return to the absolute measuring mode. After confirming with **■ ENTER** the original value is displayed. (Fig. 2)

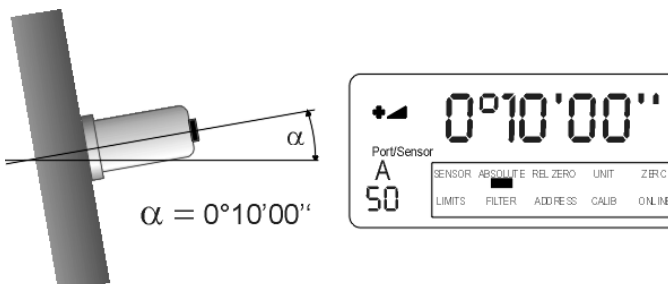

**Fig. 2**

The values stored in the stacks of „ZERO“ and „Relative Zero“ can be deleted as follows:

Press the **▲ ON/MODE** key repeatedly until the selection pointer is located under "REL ZERO" or "ZERO" and confirm with **■ ENTER**. In the display the existing value is seen. By using the key **▲** **▼** **ZERO/SELECT "+/-"** the value can be set to "0". This can now be confirmed with **■ ENTER** and the CLINO 2000 starts in the measuring mode. The stack is empty.

### 3.10. MEASURING BY SETTING LIMITS

When your task requires the indication of a surpassed measuring value with an "alarm" the LIMITS function must be used.

In this mode it is possible to define an upper and a lower **measuring limitation** (LIMITS). After installation of the limits a signal will be seen on the screen and also sent through the **port RS 232** if the measured value rises above the upper limit or falls below the lower limit.

For the setting of limits the selection pointer must be moved to the position **LIMITS** by repeatedly pressing the key **▲ ON/MODE**. If reached it needs to be accepted by pressing **■ ENTER**. In the display of the CLINO 2000 a possible installed lower limit is displayed with a marking **LO**. This value may now manually be adjusted to the required value by using

**▲▼ ZERO/SELECT „+/-“**. If reached it must be accepted by pressing **■ ENTER**. After this the upper value is displayed with the marking **HI**. This value may now manually be adjusted to the required value by using **▲▼ ZERO/SELECT „+/-“**. If reached it must be accepted by pressing **■ ENTER**.



**ATTENTION: The upper limit (HI) must always, absolutely seen, be higher than the lower limit (LOW)**

After the confirmation in the display the upper limit is seen (remark HI) This value can be changed **manually** by using the keys

**▲▼ ZERO/SELECT „+/-“** and after confirming with **■ ENTER** the limit is set.



After the saving of the upper limit the display shows **OFF** or **ON**. By using the key **▲ ON/MODE** the display jumps between the two possibilities.

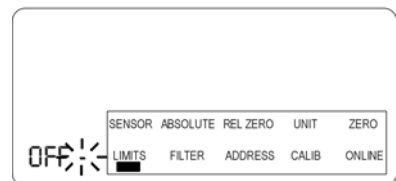

The desired mode must be confirmed with **■ ENTER**. (Means: limits ON or limits OFF) If the limits must not be stored, the procedure can be cancelled by using **● SEND/ESC**

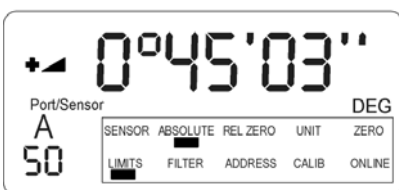

If during a measurement the limits are reached the display starts flashing, alternatively the measured value and the remark HI or LO depending on the limit reached are seen.

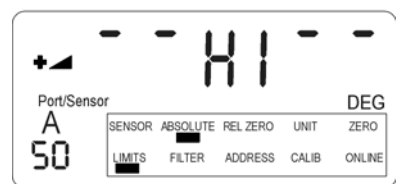

At the same time two signal will be transmitted to the **port RS 232**. The first signal may be used for an external control action or a relay (12V/500 mA) may be activated.

The second signal transmits the polarity of the signal in relation to the set limitation.



### 3.11. DIFFERENTIAL-, RESPECT REFERENCE MEASUREMENT WITH TWO CLINOTRONIC 2000

Applying differential measurement respectively reference measurement means by definition using two instruments, a **Measuring Instrument (A)** and a **Reference Instrument (B)**, whereas the difference between the two angles is of interest (A-B). This difference remains unchanged when the same angular change is applied on both instruments. This measurement is a special form of a relative measurement.

The differential measurement has the greatest advantages in the following tasks:  
Measurements made on objects under influence of vibration  
Measurements made on objects and systems not rigid enough (unstable, flimsy)

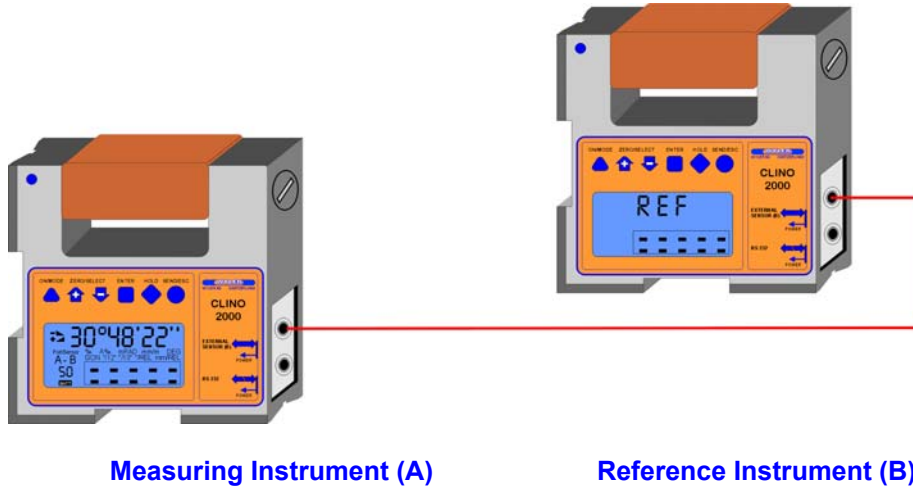

#### Preconditions:

- Both instruments are powered by either internal batteries in each instrument or by using an external power supply connected to one of the two instrument's free socket "RS232"
- Both instruments are connected together using the ports "EXTERNAL SENSOR (B)", with a bus cable (max. 1000 m)

#### Start-up

Both instruments are placed in position and properly connected and power supply installed as mentioned above.

First the Reference instrument must be started by pressing the button **▲ ON/MODE**.

The **▲ ON/MODE** key must now be pressed repeatedly until the selection pointer is below ONLINE and accepted by pressing **■ ENTER**. The display shows now "REF" what means that the instrument is in the reference mode.



Secondly the Measuring instrument must be started by pressing the button ▲ **ON/MODE**.

The ▲ **ON/MODE** key must now be pressed repeatedly until the selection pointer is below **SENSOR** and confirmed by pressing ■ **ENTER**. The "Port A-B" must be selected for choosing differential mode, applying the key ▲/▼ **ZERO/SELECT** "+/-" until the desired selection is displayed, then accept by pressing ■ **ENTER**. After this the CLINO 2000 is looking for all the connected sensors respectively their address. The correct addresses of (A) and (B) must be confirmed with ■ **ENTER**.

**Remarks:**

When the differential mode is selected for the first time with the two respective instruments all the calibration data must be collected and computed, this task will usually take up to two minutes time. After this the start-up time will be usually be reduced to approximately 20 to 30 seconds.

On the display of the measuring instrument the measuring result (value of measuring instrument minus value of reference instrument, A-B) is now seen.

As long as the installed configuration remains the same only the ▲ **ON/MODE** key must be pressed on the two instruments for a renewed start-up.

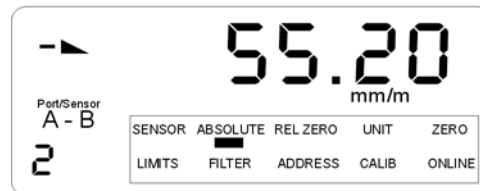

## 4. ERROR MESSAGES

<b>ERROR 0</b>	Instrument's fault, <b><u>needs to be sent to the service center</u></b>
<b>ERROR 1</b>	Sensor(s) /Instrument(s) not connected, or not correct address
<b>ERROR 2</b>	No measuring has been made with the connected sensor. The sensor must be addressed first (See point 3.7. Selecting a sensor or an instrument)
<b>ERROR 3</b>	No calibration data available (the respective sensor/port is displayed)
<b>ERROR 4</b>	No sensor address found
<b>ERROR 5</b>	More than one sensor found
<b>ERROR 6</b>	Changing of sensor address was not successful
<b>ERROR 7</b>	HOLD function has not been successfully completed within 60 seconds. The procedure needs to be repeated.
<b>ERROR 8</b>	Battery not correctly installed
<b>ERROR 9</b>	It was not possible to save the calibration data successfully in the sensor head

### Remarks:

After the error message is displayed and confirmed with **ENTER** the position indicator jumps to the position **SENSOR** (select sensor)

## 5. SERVICE

### 5.1. GENERAL

The CLINO 2000 needs no special service other than the regular cleaning.

### 5.2. STORAGE

The CLINO 2000 should be stored in a save place, best in the transportation case. For longer storage periods it is recommended to remove the batteries.

### 5.3. SPARE PARTS

The following spares are available:

- Batteries
- Cables

### 5.4. CHANGING OF SENSOR ADDRESS

Move the position indicator to the position **ADDRESS** by repeatedly pressing the key **ON/MODE** and confirm the setting with **ENTER**. If only one sensor is connected as described above the respective port and address number is displayed flashing.

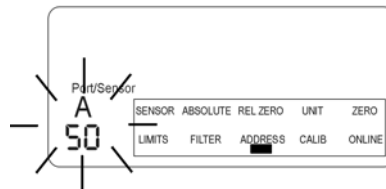

**Remarks:** If more than one sensor is connected, the error message ERROR 5 is displayed. (More than one sensor found)

Using the keys **↑** **↓** **ZERO/SELECT** the new address can be entered and confirmed by pressing **ENTER**. If the procedure was successful the measurement starts with the newly given address.

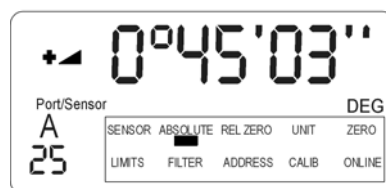

Addresses of **external Zerotronic sensors** may be chosen between no. 1 and no. 254  
Addresses of **external Measuring instruments** (Minilevel NT, Leveltronic NT) may only be chosen between no. 1 and no. 32  
The address no 255 is reserved for service purposes and should not be used.

**The address of the internal sensor of the CLINO 2000 can't be changed.**

The following error messages are possible:

<b>ERROR 4</b>	No sensor address found
<b>ERROR 5</b>	More than one sensor found
<b>ERROR 6</b>	Changing of sensor address was not successful

## 5.5 CALIBRATION

### 5.5.1 QUICK CALIBRATION

The CLINO 2000 is equipped with an integrated calibration set-up for a quick calibration procedure. On the backside of the instrument a number of precisely manufactured and placed holes are available for installing the dowel pins as calibration aids. These pins are part of the delivery and can be inserted into the holes. With the quick calibration method the values at + and - 45° as well as the exact zero value can be fixed. By this procedure the instrument can be set to a sufficiently high precision for most of the applications.

The calibration procedure is as follows:

1. Start the instrument in the mode „Absolute“
2. Select menu „ZERO“ and confirm with **ENTER**
3. Press „MODE“ shortly (less than 5 sec.)
4. Adjustment of angle at +45°,  
Pre-set value will be displayed  
The dowel pins are to be inserted in such a way that the instrument would display +45° when two pins are on a horizontal plane.  
E.g. hold the instrument on the side of a measuring and setting plate, the pins on top.  
Press HOLD, keep the instrument stable  
First displayed is 00000, then the measured value is seen.  
Confirm with **ENTER**
5. Adjustment of angle at 0°,  
Pre-set value will be displayed  
The dowel pins are to be inserted in such a way that the instrument would display 0° when two pins are on a horizontal plane.  
E.g. hold the instrument on the side of a measuring and setting plate, the pins on top.  
Press HOLD, keep the instrument stable  
First displayed is 00000, then the measured value is seen.  
Confirm with **ENTER**
6. Adjustment of angle at -45°,  
Pre-set value will be displayed  
The dowel pins are to be inserted in such a way that the instrument would display -45° when two pins are on a horizontal plane.  
E.g. hold the instrument on the side of a measuring and setting plate, the pins on top.  
Press HOLD, keep the instrument stable  
First displayed is 00000, then the measured value is seen.  
Confirm with **ENTER**
7. During the sampling of the collected values first displayed is: . . . . ., then 00000, at the end it will automatically switch in the measuring mode
8. By applying a reversal measurement set the instrument to absolute zero (see point 3.2.1)
9. The CLINO 2000 is now calibrated and can be used for measuring.

Point 3.9.1

Press **▲ ON/MODE** several times until the selection pointer is below ZERO

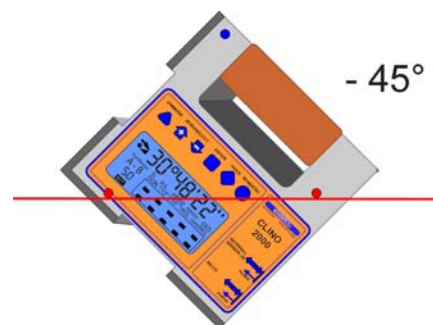
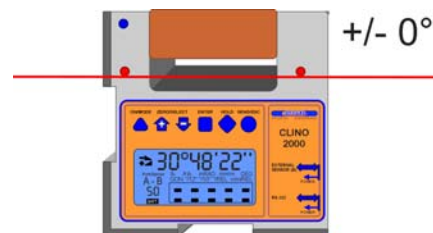
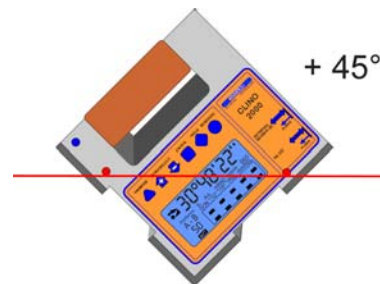

**The calibration aids (dowel pins) must be stored grease applied and any damage is to be prevented. Also the holes in the instrument must remain free of dust and dirt.**

## 5.5.2 FINE CALIBRATION OVER THE WHOLE MEASURING RANGE

The fine calibration may be required when

- the existing calibration was lost
- the accuracy is not sufficient anymore
- a connected sensor or the measuring range has changed

For such a calibration procedure a precise sine bar or an accurate index table should be available.

**Remarks:** In order to guarantee the precise functioning of the instrument a minimum of seven calibration points are required over the whole measuring range.

### Principle of the calibration method

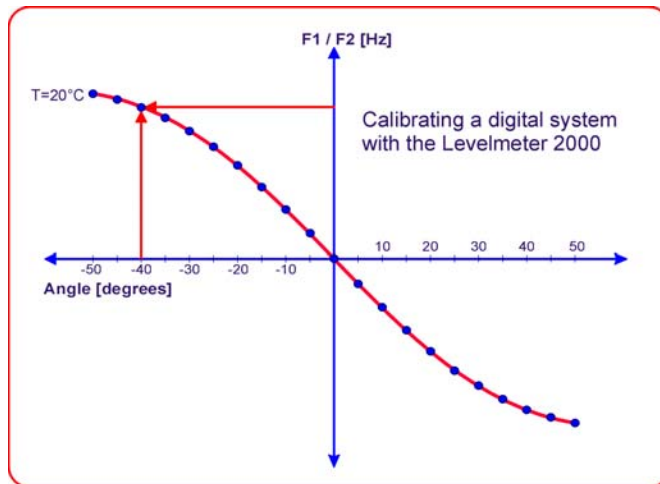

The bases of all the measurements with digital technology like the CLINO 2000 and the connected sensors/instruments are the calibration data stored in the sensor heads. Throughout the whole measuring range a number of reference calibrating points are stored in the sensor heads. The linearity of the measuring range depends on the number of these reference-calibrating points. Each measured angle delivers a signal in form of a frequency and to these reference frequencies the respective calibration points are matched. From these values a calibration curve will be established.

The measured angles between these calibration points are computed by interpolation and displayed on the screen in the desired measuring unit.

All sensors/instruments leaving the factory at WYLER's are calibrated according the measuring range and have undergone a severe quality test procedure.

For the calibration procedure the selection pointer must be moved to the position **CALIB** by repeatedly pressing the key **▲ ON/MODE**. If reached it needs to be accepted by pressing **■ ENTER**. By using the key **▲▼ ZERO/SELECT „+/-“** the respective port may be chosen. „**Port A**“, for the internal sensor in the CLINO 2000, „Port B“ for a possible external sensor. The selected possibility must be confirmed by pressing **■ ENTER**.

After this the CLINO 2000 is looking for all the connected sensors respectively their address. The address of the sensor will be displayed flashing. During the searching procedure the frame of the „**Sensor address**“ will flash in circular motion below the selected port.

Are several sensors connected the required one must be selected by the key **▲▼ ZERO/SELECT „+/-“** and confirmed with **■ ENTER**.

Immediately after this the calibration procedure is starting.

In the display the last entered distance between two calibration points is seen. By using the key **▲▼ ZERO/SELECT „+/-“** this distance may be entered from new. Two basic possibilities are available:

- I) Choose calibration point distance is between 0.5 and 7.5 degrees, in steps of 0.5 degrees.
- II) Choose calibration point distance is between 1.0 and 15.0 mm/m, in steps of 1.0 mm/m.

For calibrating the CLINO 2000 it is recommended to use 5° 7.5° steps.

After choosing the distance and confirming with **■ ENTER** the procedure continuous as follows:

- In the area of the sensor address the number of calibrating points is displayed (incl. zero position)
- In the major display area the total calibration range to be calibrated is seen (Result of number of calibration points and the distances chosen).

By applying **▲▼ ZERO/SELECT „+/-“** the number of calibration points may be changed. The corresponding calibration range will automatically adjust. Confirm with **■ ENTER**.

In the display the first angle to set is seen flashing. In the window „Address Sensor“ the number 1 is seen for the first calibration point to be set.

The CLINO 2000 or the external sensor must now be set to the first calibrating position on a suitable calibration gauge (rotary table, sine bar). This angle is displayed flashing on the screen and the figure 1 is seen which stands for the first calibration point.

If the correct position is installed and a few seconds settling time were allowed the value can be saved by pressing **ENTER**. During the reading of the data the display remains stable. After successful reading the next calibration point will be displayed and the respective procedure must continue.

Example	Measuring range of CLINO 2000	+/- 45 degrees
	Distance between the calibrating points	5.000 degree
	Number of calibrating points	23
	Range of calibration	+/- 50 degrees
Result	1. Calibration point	- 55.000°
	2. Calibration point	- 50.000°
	3. Calibration point	- 45.000°
	.....	
	21. Calibration point	+ 55.000°

After entering the last calibration point the complete calibration data will be saved in the sensor head. During this procedure a moving bar is displayed and when successful finished the CLINO 2000 switches to the measuring mode.

If something went wrong the following message shows up:

**ERROR 9**

It was not possible to save the calibration data successfully in the sensor head

**Remarks:** The „ZERO-OFFSET“ and the „REL ZERO OFFSET“ will be set to zero.  
Until the definitive saving of the calibration values the procedure may be stopped by using ESC.



## 6. TECHNICAL DATA

<b>Measuring range/ Messbereich</b>	Optional:	<b>± 45 Arc.deg.</b>  ± 10 Arc.deg. ± 30 Arc.deg. ± 60 Arc.deg.
Calibration / Kalibrierung	Built-in software and calibration aids  Interne Kalibriersoftware und mitgelieferte Kalibrierhilfen	23 Setting points /  23 Kalibrierpunkte
Settling time / Messzeit	Value available after / Anzeige nach	< 5 sec.
Resolution / Auflösung	Depending on units set  Abhängig von ausgewählter Masseinheit	5 Sec. of arc (≈ 0.025 mm/m)
Limits of error / Fehlergrenze	  After quick calibration, using the calibration aids  Nach Kurzkalibrierung mit den Kalibrierhilfen	< 5 Sec. of arc + 0.07%R.O.    < 30 Sec. of arc
Data connection / Anschluss	Special cables / Spezialkabel	RS 485, asynchr., 7 Bit, 2 Stopbits, no parity, 9600 Baud
Power supply with batteries (Lifetime)  Stromversorgung mit Batterien (Betriebsdauer)	Batteries:  Option, rechargeable batteries:	2 x Size AA 1.5V Alkaline (40 - 60 hrs)  2 x Size AF 1,2 V NiMH rechargeable (30-50 hrs)
External power supply / Externe Speisung		+12... +48 V DC / 200 - 500 mW
Housing (Weight) / Gehäuse (Gewicht)	Stainless steel / Stahl rostfrei	150 x 150 x 35 mm (3 kg)
Temp. range /  Temp. -Bereich	Operating / Betriebstemperatur  Storage / Lagertemperatur	0° to 40 °C.    -20° to 70 °C.

Remarks/Bemerkungen: F.S.=Full Scale; R.O.=Read Out;

**Remarks:** The instruments are delivered with batteries of AA type. When using the type AF, the installed spacer is to be removed.

When using external power supply the batteries may remain in the instrument.  
Rechargeable batteries must be charged outside of the instrument