



**IPC912-213-FL Series**  
**Industrial & Fanless Computers**  
**User's Manual**



## **Disclaimers**

This manual has been carefully checked and believed to contain accurate information. Axiomtek Co., Ltd. assumes no responsibility for any infringements of patents or any third party's rights, and any liability arising from such use.

Axiomtek does not warrant or assume any legal liability or responsibility for the accuracy, completeness or usefulness of any information in this document. Axiomtek does not make any commitment to update the information in this manual.

Axiomtek reserves the right to change or revise this document and/or product at any time without notice.

No part of this document may be reproduced, stored in a retrieval system, or transmitted, in any form or by any means, electronic, mechanical, photocopying, recording, or otherwise, without the prior written permission of Axiomtek Co., Ltd.

**©Copyright 2012 Axiomtek Co., Ltd.**

**All Rights Reserved**

**July 2012, Version A1**

**Printed in Taiwan**

## Safety Precautions

Before getting started, please read the following important safety precautions.

1. The IPC912-213-FL Series does not come equipped with an operating system. An operating system must be loaded first before installing any software into the computer.
2. Be sure to ground yourself to prevent static charge when installing the internal components. Use a grounding wrist strap and place all electronic components in any static-shielded devices. Most electronic components are sensitive to static electrical charge.
3. Disconnect the power cord from the IPC912-213-FL Series before making any installation. Be sure both the system and the external devices are turned OFF. Sudden surge of power could ruin sensitive components. Make sure the IPC912-213-FL Series is properly grounded.
4. Make sure the voltage of the power source is correct before connecting the equipment to the power outlet.
5. Turn OFF the system power before cleaning. Clean the system using a cloth only. Do not spray any liquid cleaner directly onto the screen.
6. Do not leave this equipment in an uncontrolled environment where the storage temperature is below  $-20^{\circ}\text{C}$  or above  $80^{\circ}\text{C}$ . It may damage the equipment.
7. Do not open the system's back cover. If opening the cover for maintenance is a must, only a trained technician is allowed to do so. Integrated circuits on computer boards are sensitive to static electricity. To avoid damaging chips from electrostatic discharge, observe the following precautions:
  - Before handling a board or integrated circuit, touch an unpainted portion of the system unit chassis for a few seconds. This will help to discharge any static electricity on your body.
  - When handling boards and components, wear a wrist-grounding strap, available from most electronic component stores.

## Classification

1. Degree of protection against electric shock: not classified
2. Degree of protection against the ingress of water: IPX0
3. Equipment not suitable for use in the presence of a flammable anesthetic mixture with air or with oxygen or nitrous oxide.
4. Mode of operation: Continuous
5. Type of protection against electric shock: Class I equipment

## General Cleaning Tips

You may need the following precautions before you begin to clean the computer. When you clean any single part or component for the computer, please read and understand the details below fully.

When you need to clean the device, please rub it with a piece of dry cloth.

1. Be cautious of the tiny removable components when you use a vacuum cleaner to absorb the dirt on the floor.
2. Turn the system off before you start to clean up the component or computer.
3. Never drop the components inside the computer or get circuit board damp or wet.
4. Be cautious of all kinds of cleaning solvents or chemicals when you use it for the sake of cleaning. Some individuals may be allergic to the ingredients.
5. Try not to put any food, drink or cigarette around the computer.

### Cleaning Tools:

Although many companies have created products to help improve the process of cleaning your computer and peripherals users can also use household items to clean their computers and peripherals. Below is a listing of items you may need or want to use while cleaning your computer or computer peripherals.

Keep in mind that some components in your computer may only be able to be cleaned using a product designed for cleaning that component, if this is the case it will be mentioned in the cleaning.

- Cloth: A piece of cloth is the best tool to use when rubbing up a component. Although paper towels or tissues can be used on most hardware as well, we still recommend you to rub it with a piece of cloth.
- Water or rubbing alcohol: You may moisten a piece of cloth a bit with some water or rubbing alcohol and rub it on the computer. Unknown solvents may be harmful to the plastics parts.

- Vacuum cleaner: Absorb the dust, dirt, hair, cigarette particles, and other particles out of a computer can be one of the best methods of cleaning a computer. Over time these items can restrict the airflow in a computer and cause circuitry to corrode.
- Cotton swabs: Cotton swabs moistened with rubbing alcohol or water are excellent tools for wiping hard to reach areas in your keyboard, mouse, and other locations.
- Foam swabs: Whenever possible it is better to use lint free swabs such as foam swabs.



**Note:** *It is strongly recommended that you should shut down the system before you start to clean any single components.*

**Please follow the steps below:**

1. Close all application programs
2. Close operating software
3. Turn off power switch
4. Remove all device
5. Pull out power cable

## **Scrap Computer Recycling**

If the computer equipments need the maintenance or are beyond repair, we strongly recommended that you should inform your Axiomtek distributor as soon as possible for the suitable solution. For the computers that are no longer useful or no longer working well, please contact your Axiomtek distributor for recycling and we will make the proper arrangement.

## **Trademarks Acknowledgments**

Axiomtek is a trademark of Axiomtek Co., Ltd. IBM, PC/AT, PS/2, VGA are trademarks of International Business Machines Corporation.

AMI are trademarks of American Megatrend Inc.

Intel® Core™ i3 LGA1155 Desktop Processor,

Intel® Core™ i5 LGA1155 Desktop Processor,

Intel® Core™ i7 LGA1155 Desktop Processor,

are registered trademarks of Intel Corporation.

Other brand names and trademarks are the properties and registered brands of their respective owners.

# Table of Contents

Disclaimers .....	ii
Safety Precautions.....	iii
Classification.....	iv
General Cleaning Tips.....	iv
Scrap Computer Recycling .....	vi
<b>CHAPTER 1 INTRODUCTION.....</b>	<b>1</b>
1.1    General Description .....	2
1.2    System Specifications .....	2
1.2.1  Main CPU Board .....	2
1.2.2  I/O System .....	3
1.2.3  System Specification.....	4
1.3    Dimensions .....	5
1.4    I/O Outlets.....	6
1.5    Jumper Settings.....	7
1.6    Packing List.....	11
<b>CHAPTER 2 HARDWARE INSTALLATION .....</b>	<b>13</b>
2.1    Installing the Processor.....	13
2.2    Installing the Memory Module .....	15
2.3    Installing the Hard Disk Drive.....	17
2.4    Installing the PCI or PCIe Card.....	19
<b>CHAPTER 3 AMI BIOS UTILITY .....</b>	<b>21</b>
3.1    Starting.....	21
3.2    Navigation Keys .....	22
3.3    Main Menu .....	23
3.4    Advanced Menu .....	24
3.5    Chipset Menu .....	31
3.6    Boot Menu.....	36
3.7    Security Menu .....	37
3.8    Save & Exit Menu.....	38

# ***MEMO***



# CHAPTER 1 INTRODUCTION



This chapter contains general information and a detailed specification of the IPC912-213-FL Series. Chapter 1 includes the following sections:

- General Description
- System Specification
- Dimensions
- I/O Outlets
- Package List

## 1.1 General Description

The IPC912-213-FL Series is a fanless system that can support Intel® Core™ i7/i5/i3 processors. The IPC912-213-FL Series supports Windows® XP, and Windows® XP embedded Windows 7, and Fedora, suitable for the most endurable operation. Reliable and Stable Design

- The IPC912-213-FL Series adopts two anti-vibration hard-drive bays, which makes it especially suitable for vibration environments, best for industrial automation, digital signage and gaming application.
- Embedded O.S. Supported

The IPC912-213-FL Series not only supports Windows® XP, but also supports embedded OS, such as Windows® XP embedded. For storage device, the IPC912-213-FL Series supports one 2.5" HDD driver bay and one onboard CompactFlash™ socket.

## 1.2 System Specifications

### 1.2.1 Main CPU Board

- **CPU**
  - Socket G2 Intel® Core™ i7/i5/i3 processors, up to 35W
- **System Chipset**
  - Intel® HM65 chipset
- **BIOS**
  - AMI BIOS, with Smart View and Customer CMOS Backup.
- **System Memory**
  - Two 204-pin DDR3 1066/1333 MHz SODIMM sockets, with maximum up to 8GB
- **Features**
  - Fanless Operation
  - Compact & Front IO design
  - Supports Two expansion slots
  - DC to DC power supply support 10V to 30V

---

## 1.2.2 I/O System

- **Standard I/O Interface -- Front**

- ATX power on/off switch
- One 2-pin connector output for remote power on/off switch
- 10VDC to 30VDC with phoenix power plug or External 150W AC Adapter
- Six USB 2.0 ports
- HDD access/Power LEDs
- Three RS232(COM 2/3/4)
- One RS232/422/485(COM 1)
- One VGA connector
- Two G.E. LAN ports

- **Expansion Slot**

- HAB100: One PCIe1 & One PCIe4 or Two PCIe1
- HAB102: One PCIe4 & One PCI-X
- HAB103: One PCI & One PCIe4



**NOTE:***The maximum power rating for expansion slots at 45°C can not be exceeded the following values*

**\*\* The maximum loading of 3.3V + 5.0Vsb + 5V is <49W.**

**\*\* The maximum loading of 3.3V + 5.0V+12V is <74W.**

### 1.2.3 System Specification

- **Drive Capacity**
  - Supports One 2.5" HDD driver bay; one onboard CFast Socket
- **Power Input**
  - 10VDC to 30VDC with phoenix power plug
  - External 150W AC Adapter
    - Power Input : 100VAC to 240VAC, 2A, 50~60HZ
    - Power Output : 19VDC
- **Operation Temperature**
  - Ambient with air flow: 0°C ~ 45°C
- **Storage Temperature**
  - -20°C ~ 80°C
- **Humidity**
  - 10% ~ 90% (Non-condensing)
- **Dimensions**
  - 142mm (5.6") (W) x 248 mm (9.8") (D) x 185mm (7.3") (H)



**NOTE:** All specifications and images are subject to change without notice.

### 1.3 Dimensions

The following diagrams show you dimensions and outlines of the IPC912-213-FL Series.

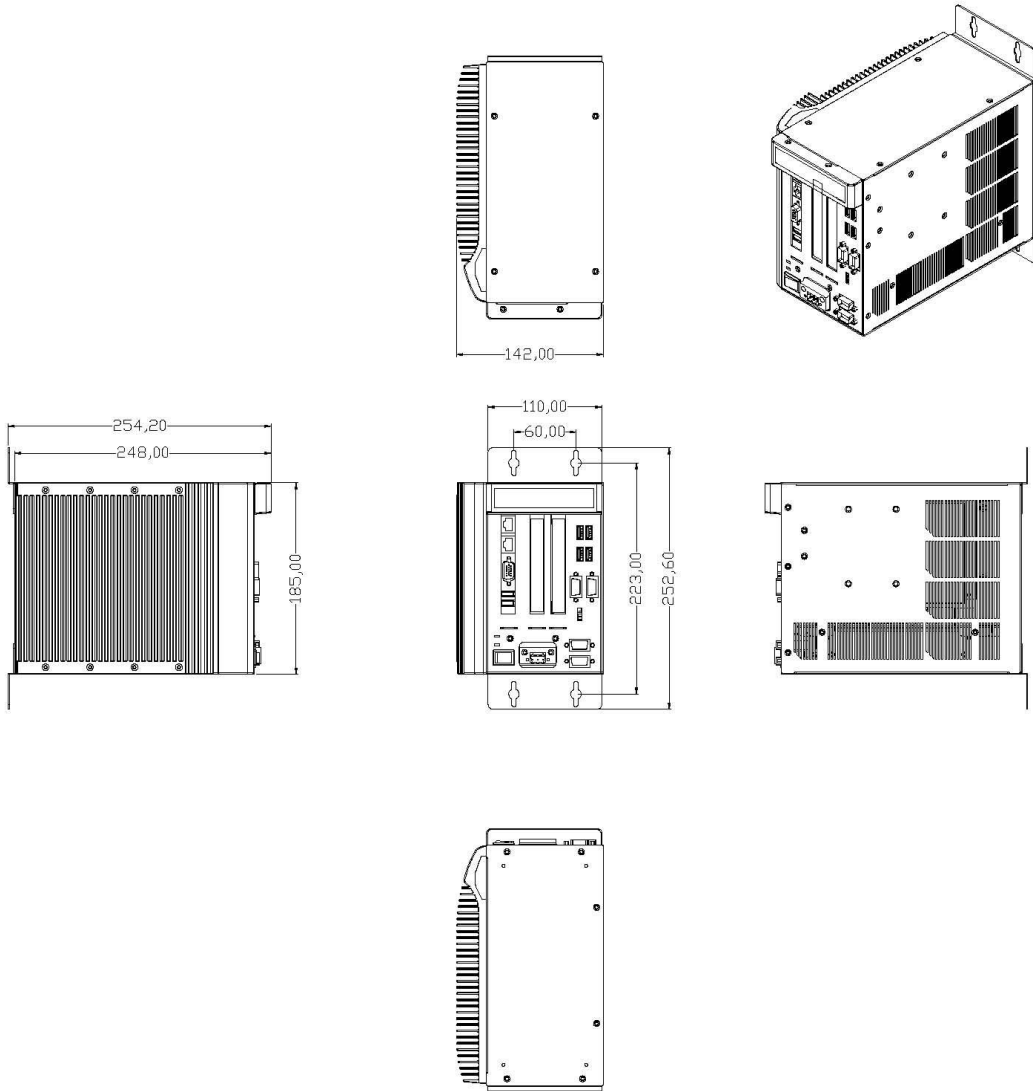

## 1.4 I/O Outlets

The following figures show you I/O outlets on front and rear panels of the IPC912-213-FL Series.

### Front Panel

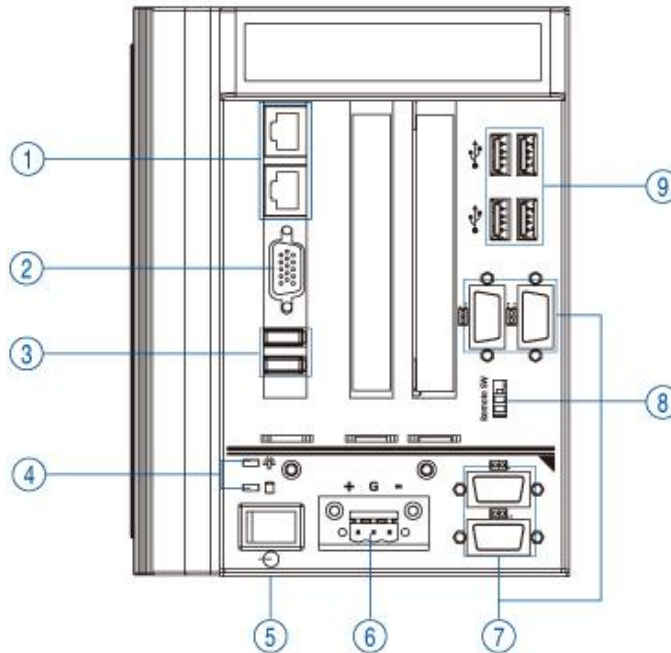

1. Ethernet x 2
2. VGA Port
3. USB 2.0 x 2
4. LED for Power & HDD
5. ATX Power Switch
6. Power Connector (AC-IN or Phoenix Plug)
7. RS-232/422/485(COM1)  
RS-232(COM 2/3/4)
8. Remote power switch
9. USB 2.0 x 4

## 1.5 Jumper Settings

The IPC912-213-FL has a number of jumpers inside the chassis that allow you to configure your system to suit your application. The table below lists the functions of the various jumpers.

Jumper	Default Setting		Jumper Setting
JP4	COM1 Mode Selection Default: RS-232		Short 1-2
JP3	COM1 Mode Selection Default: RS-232		Short 3-5, 4-6
JP5	COM1 Mode Selection Default: RS-232		Short 3-5, 4-6
JP1	COM1 Mode Select	COM1 Pin 1: DCD	Short 3-5
		COM1 Pin 8: RI	Short 4-6
JP2	COM2 Mode Select	COM2 Pin 1: DCD	Short 3-5
		COM2 Pin 8: RI	Short 4-6
JP7	Auto-Power Button Selection Default: Manual Power Button		Short 1-2

### 1.5.1

These jumpers select the COM1 port's communication mode to operate RS-232 or RS-422/485.

Description	Function	Jumper Setting		
COM1	RS-232 (Default)	<p><b>JP4</b></p>	<p><b>JP3</b></p>	<p><b>JP5</b></p>
	RS-422	<p><b>JP4</b></p>	<p><b>JP3</b></p>	<p><b>JP5</b></p>
	RS-485	<p><b>JP4</b></p>	<p><b>JP3</b></p>	<p><b>JP5</b></p>

Description	Function	Jumper Setting
COM1	CN2 Pin 1=5V	
	CN2 Pin 1=DCD (Default)	
	CN2 Pin 8=12V	
	CN2 Pin 8=RI (Default)	



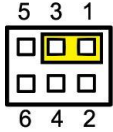
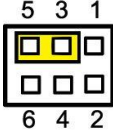
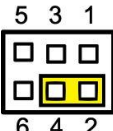
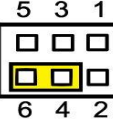

## 1.5.2

These jumpers select the COM2 port's communication mode to operate RS-232 or RS-422/485.

Description	Function	Jumper Setting
COM2	CN4 Pin 1=5V	
	CN4 Pin 1=DCD (Default)	
	CN4 Pin 8=12V	
	CN4 Pin 8=RI (Default)	

### 1.5.3

Use this jumper to select either Auto or Manual Button.

Description	Function	Jumper Setting
Auto-Power Button Selection	Manual Power Button (Default)	
	Automatic Power Button	

## **1.6 Packing List**

The package bundled with your IPC912-213-FL Series should contain the following items:

- IPC912-213-FL Series Unit x 1
- 19V 150W Adapter (for IPC912-213-FL AC Version)
- Driver CD
- Quick Manual
- Wall Mount Bracket x 2
- HD Bracket x 1
- Screw pack x 1
- Food pad x 4

If you can not find this package or any items are missing, please contact Axiomtek distributors immediately.

**MEMO:**

## CHAPTER 2 HARDWARE INSTALLATION

The IPC912-213-FL Series are convenient for your various hardware configurations, such as CPU (Central Processing Unit), Memory Module, HDD (Hard Disk Drive) and PCIe card. The chapter 2 will show you how to install the hardware. It includes:

### 2.1 Installing the Processor

The Intel® Core™ i7/i5/i3 processors are available as a boxed processor for IPC912-213-FL system. Intel recommends the processors should be installed by a computer professional since this electronic device may cause serious damage to the installer, system and processor if installed improperly.

***Important Notes*** Before attempting to install a new processor, carefully review the documentation that came with your system and make sure that you will not be voiding your warranty by opening the computer or replacing your processor.

#### Instructions:

1. Make sure that your system can accommodate the Intel® Core™ i7/i5/i3 Processors that you want to install. Check for motherboard, BIOS, and thermal compatibility by using the manufacturer's documentation for the system, or by contacting the vendor if necessary. This processor should only be installed in systems supporting the Intel® Core™ i7/i5/i3 Processors.
2. Obtain access to your processor socket as described in the documentation for your system.
3. If the cooling solution prevents you from accessing the processor socket, you may need to remove it. Instructions on how to remove your cooling solution should be provided in the documentation that came with the system.
4. To un-install the current processor, use a screwdriver to disengage (open) the socket actuator, as shown in Figure 1 below. (The most commonly used sockets are Molex\* or FoxConn\* sockets, so they are used in the illustrations below.) The socket actuator should open after only a half turn or so, and you should then be able to remove the processor with your fingers.

**Procedure of Installation:**

- Step 1** Turn off the system.
- Step 2** Disconnect the power connector.
- Step 3** Loosen screws to remove the top side cover from the chassis.



- Step 4** After opening the top and side covers, you can locate the CPU socket as marked. Align pins of the CPU with pin holes of the socket. Be careful of the CPU's orientation that you need to align the arrow mark on the CPU with the arrow key on the socket. Place the CPU into the socket, and use a screwdriver to lock it onto the socket.

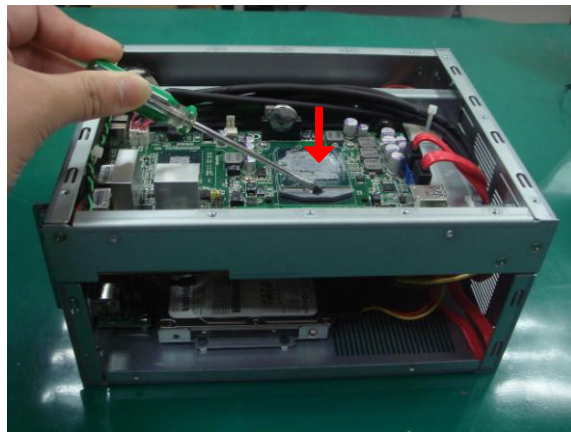

- Step 5** Close the top and side covers back to the chassis, and fasten all screws.

## 2.2 Installing the Memory Module

- Step 1** Turn off the system.
- Step 2** Disconnect the power connector.
- Step 3** Loosen screws to remove the side cover from the chassis.



- Step 4** Please follow steps below to install the upper memory module:
  - 1. Align the memory module with the socket that notches of memory module must match the socket keys for a correct installation.



2. Install the memory module into the socket and push it firmly down until it is fully seated. The socket latches are clipped on to the edges of the SO-DIMM.

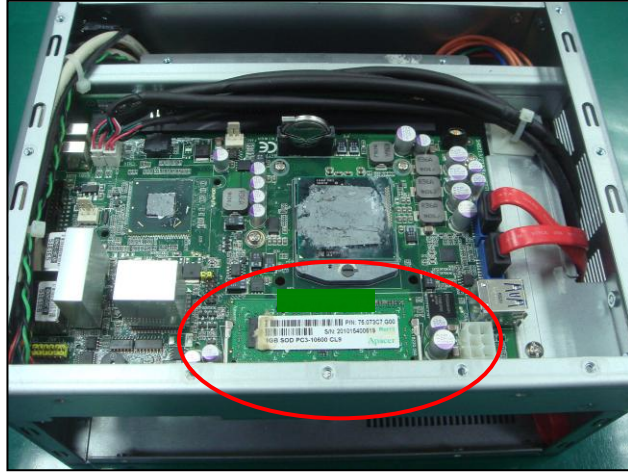

**Step 5** Put back the side cover to the chassis and fasten all screws.



## 2.3 Installing the Hard Disk Drive

The IPC912-213-FL Series offers a convenient drive bay module for users to install HDD. The system offers users one 2.5" Hard Disk Drive for installation. Please follow the steps:

- Step 1** Turn off the system.
- Step 2** Disconnect the power connector.
- Step 3** Loosen screws to remove the top cover from the chassis.

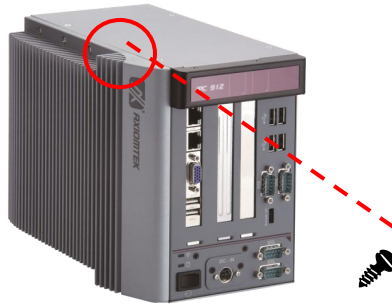

- Step 4** Open the top cover and locate the two Hard Disk Drives from the side.



**Step 5** Use assembly parts to fix HDD with the bracket.



**Step 6** Install and fix the HDD through the side, next, plug the power cable in HDD.

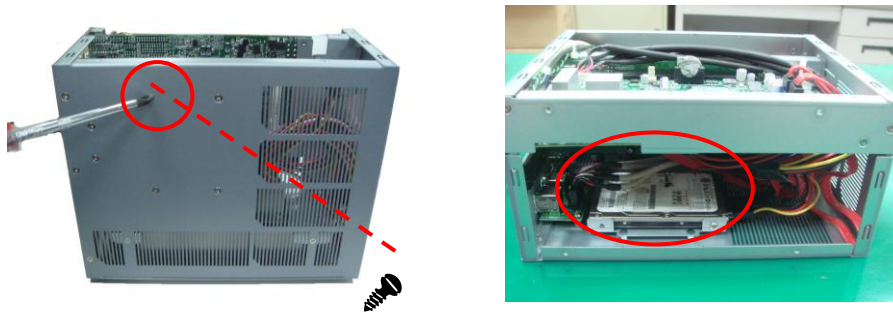

**Step 7** Close the top cover back to the chassis and fasten all screws.

## 2.4 Installing the PCI or PCIe Card

- Step 1** Turn off the system.
- Step 2** Disconnect the power connector.
- Step 3** Loosen screws to remove the top cover from the chassis. Removing the PCI or PCIe bracket by releasing the button as marked.

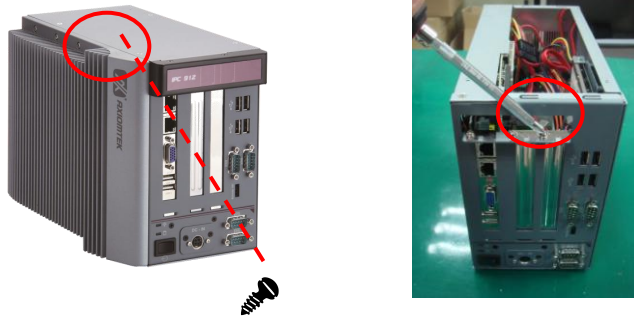

- Step 4** Locate the PCI or PCIe slots from the side.

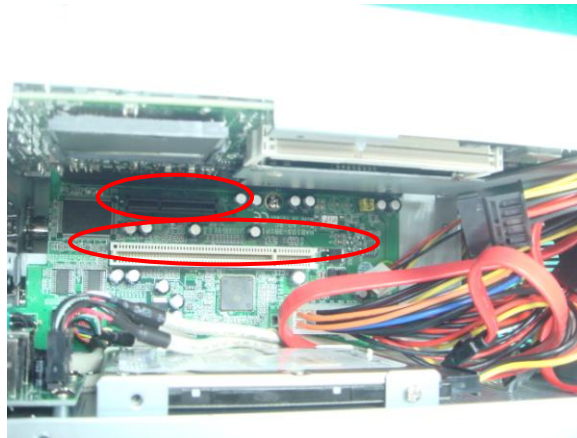

**Step 5** Align the PCI or PCIe card with the slot, and press the card into the slot until it is firmly seated.

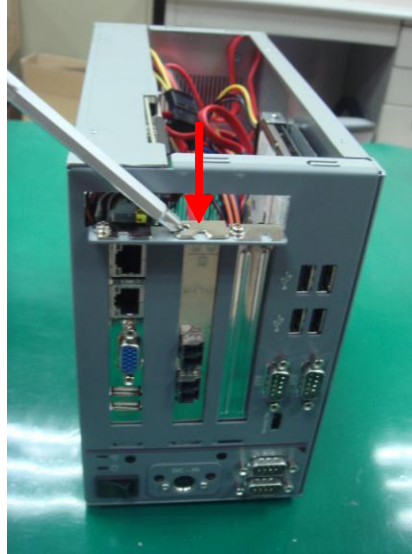

**Step 6** Close the top cover back to the chassis and fasten all screws.

## CHAPTER 3

# AMI BIOS UTILITY

The AMI UEFI BIOS provides users with a built-in setup program to modify basic system configuration. All configured parameters are stored in a 16MB flash chip to save the setup information whenever the power is turned off. This chapter provides users with detailed description about how to set up basic system configuration through the AMI BIOS setup utility.

### 3.1 Starting

To enter the setup screens, follow the steps below:

1. Turn on the computer and press the <Del> key immediately.
2. After you press the <Del> key, the main BIOS setup menu displays. You can access the other setup screens from the main BIOS setup menu, such as the Advanced and Chipset menus.



**Note:** *If your computer cannot boot after making and saving system changes with Setup, you can restore BIOS optimal defaults by setting JP1 (see section 1.5.1).*

It is strongly recommended that you should avoid changing the chipset's defaults. Both AMI and your system manufacturer have carefully set up these defaults that provide the best performance and reliability.

## 3.2 Navigation Keys

The BIOS setup/utility uses a key-based navigation system called hot keys. Most of the BIOS setup utility hot keys can be used at any time during the setup navigation process. These keys include <F1>, <F2>, <Enter>, <ESC>, <Arrow> keys, and so on.



**Note:** *Some of the navigation keys differ from one screen to another.*

Hot Keys	Description
→← Left/Right	The Left and Right <Arrow> keys allow you to select a setup screen.
↑↓ Up/Down	The Up and Down <Arrow> keys allow you to select a setup screen or sub-screen.
+– Plus/Minus	The Plus and Minus <Arrow> keys allow you to change the field value of a particular setup item.
Tab	The <Tab> key allows you to select setup fields.
F1	The <F1> key allows you to display the General Help screen.
F2	The <F2> key allows you to Load Previous Values.
F3	The <F3> key allows you to Load Optimized Defaults.
F4	The <F4> key allows you to save any changes you have made and exit Setup. Press the <F4> key to save your changes.
Esc	The <Esc> key allows you to discard any changes you have made and exit the Setup. Press the <Esc> key to exit the setup without saving your changes.
Enter	The <Enter> key allows you to display or change the setup option listed for a particular setup item. The <Enter> key can also allow you to display the setup sub- screens.

### 3.3 Main Menu

The first time you enter the setup utility, you will be in the Main setup screen. You can always return to the Main setup screen by selecting the Main tab. System Time/Date can be set up as described below. The Main BIOS setup screen is shown below.

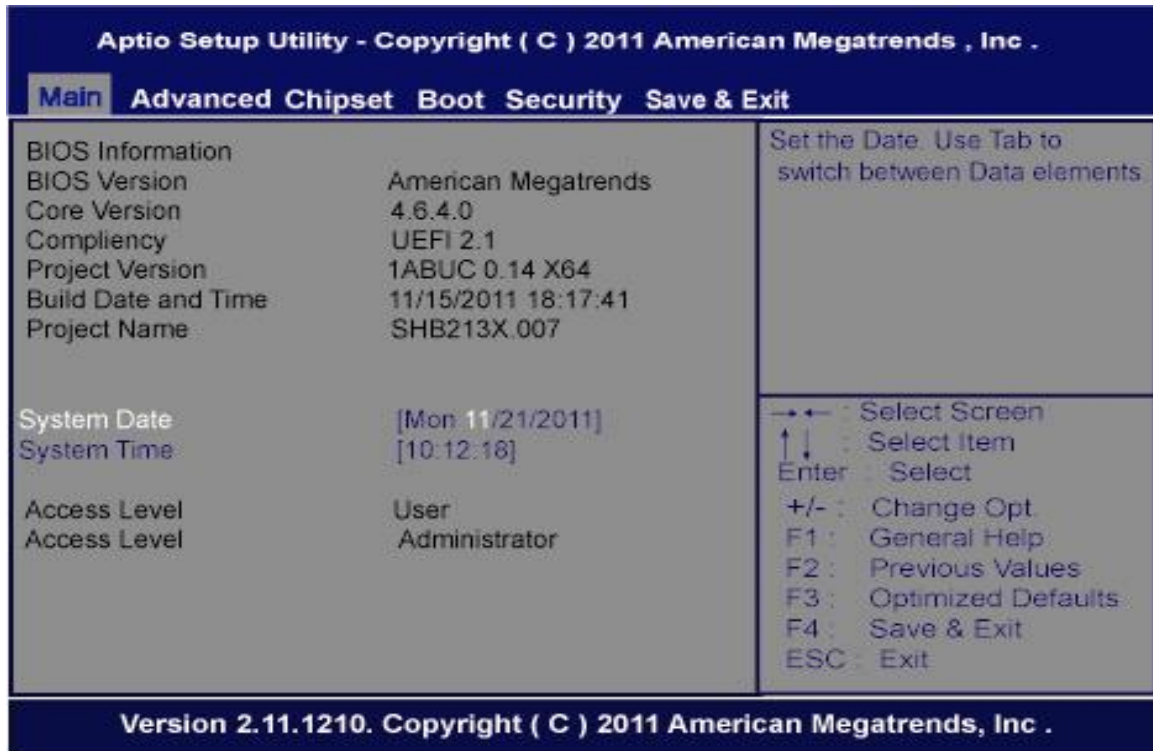

- System Language Use this item to choose the system default language.
- System Date/Time Use this option to change the system time and date. Highlight System Time or System Date using the <Arrow> keys. Enter new values through the keyboard. Press the <Tab> key or the <Arrow> keys to move between fields. The date must be entered in MM/DD/YY format. The time is entered in HH:MM:SS format.

### 3.4 Advanced Menu

- **Launch PXE OpROM**

Use this item to enable or disable the boot ROM function of the onboard LAN chip when the system boots up.

The Advanced menu also allows users to set configuration of the CPU and other system devices. You can select any of the items in the left frame of the screen to go to the sub menus:

- ▶ ACPI Settings
- ▶ CPU Configuration
- ▶ SATA Configuration
- ▶ USB Configuration
- ▶ W83627H Super IO Configuration
- ▶ W83627DHG Super IO Configuration
- ▶ W83627DHG H/W Monitor

For items marked with “▶”, please press <Enter> for more options.

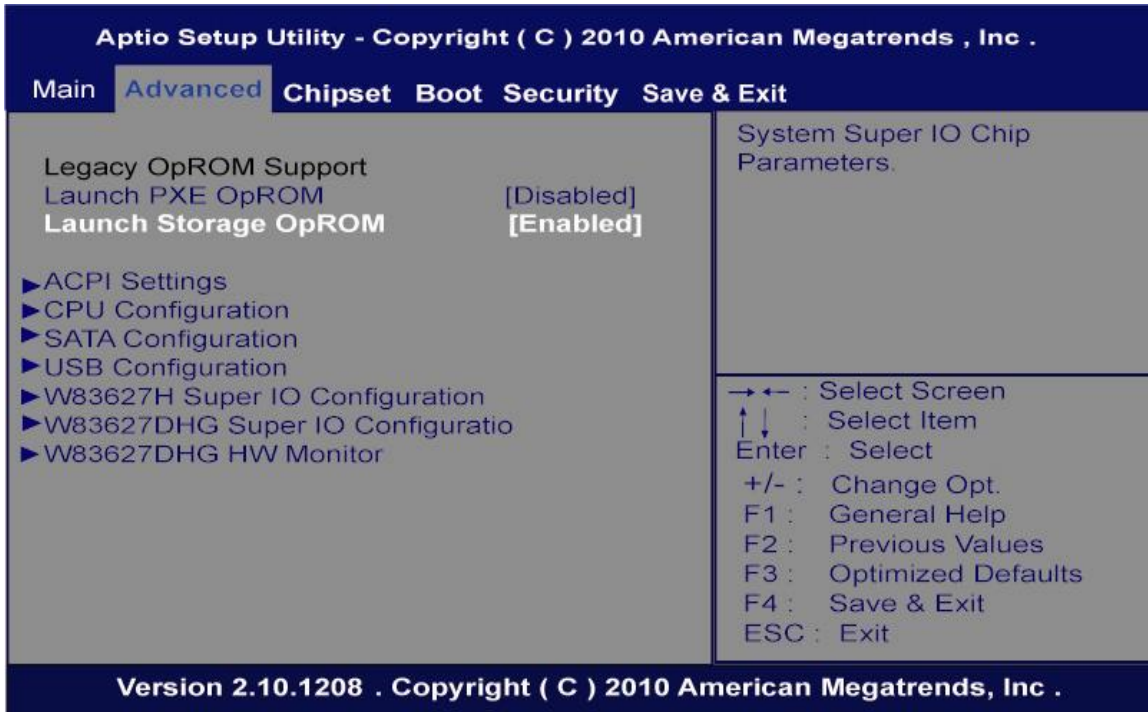



- **ACPI Settings**

ACPI configuration can be configured in ACPI Settings. A description of the selected item appears on the right side of the screen.



- **Enable ACPI Auto Configuration**

Use this item to enable or disable BIOS ACPI auto configuration.

- **Enable Hibernation**

Enable or disable system ability to hibernate (OS/S4 sleep state).

- **ACPI Sleep State**

Allow you to select the Advanced Configuration and Power Interface (ACPI) state to be used for system suspend. Here are the options for your selection; S1 (CPU Stop Clock), S3 (Suspend to RAM) and Suspend Disable

\*\*When you use S3 or S1 on XP OS, please connect your USB device on below red mark position.



➤ **S3 Video Repost**

Enable or disable S3 video repost.

● **CPU Configuration**

This screen shows the CPU Configuration, and you can change the value of the selected option.

**Aptio Setup Utility - Copyright ( C ) 2010 American Megatrends , Inc .**

**Advanced**

CPU Configuration		Enabled for Windows XP AND Linux (OS optimized for Hyper-Threading Technology) and Disabled for other OS ( OS not optimized for Hyper-Threading Technology). When Disabled only one thread per enabled core is enabled.
Intel(R) Core(TM) i5-2510E	CPU @ 2.50GHZ	
Processor Stepping	206a7	
Microcode Revision	12	
Max Processor Speed	2500 MHZ	
Min Processor Speed	800 MHZ	
Processor Speed	2500 MHZ	
Processor Cores	2	
Intel HT Technology	Supported	
EMT64	Supported	

Hyper-threading	[Enabled]
Active Processor Cores	[1]
Limit cpuid Maximum	[Enabled]
Execute Disable Bit	[Enabled]
Hardware Prefetcher	[Enabled]
Adjacent Cache Line Prefetch	[Enabled]
Intel Virtualization Technology	[Disabled]

→ ← : Select Screen  
 ↑ ↓ : Select Item  
 Enter : Select  
 +/- : Change Opt.  
 F1 : General Help  
 F2 : Previous Values  
 F3 : Optimized Defaults  
 F4 : Save & Exit  
 ESC : Exit

**Version 2.10.1208. Copyright ( C ) 2010 American Megatrends, Inc .**

➤ **Node 0 Information**

View memory information related to Node 0.

- **SATA Configuration**

you can read the current installed hardware configurations from those SATA ports in the SATA Configuration menu. During system boot up, BIOS will detect the present SATA devices automatically.



● **USB Configuration**

USB configuration can be configured here by selecting and changing each item. A description of the selected item appears on the right side of the screen.

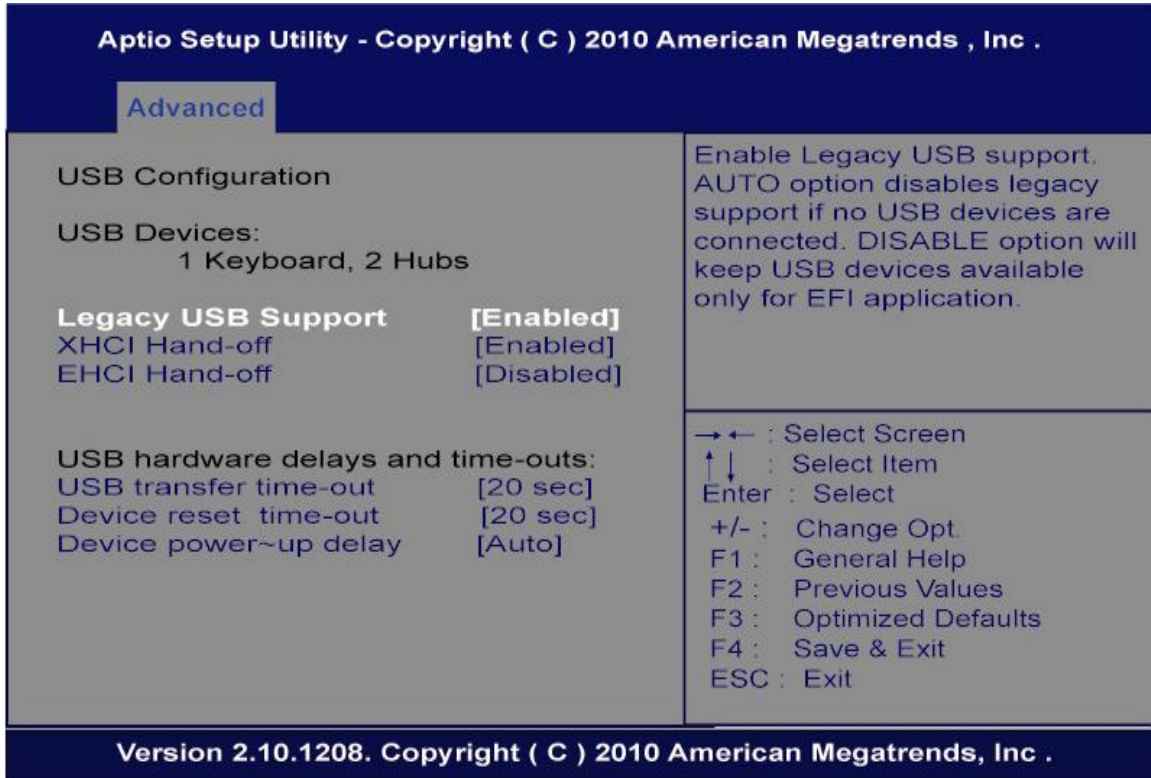

➤ **Legacy USB Support**

Use this item to enable or disable support for USB device on legacy operating system. The default setting is Enabled. Auto option disables legacy support if no USB devices are connected. Disable option will keep USB devices available only for EFI applications.

➤ **USB transfer time-out**

The time-out value for control, bulk and interrupt transfers.

➤ **Device reset time-out**

USB mass storage device start unit command time-out.

➤ **Device power-up delay**

Maximum time the device will take before it properly reports itself to the host controller. “Auto” uses default value: for a root port it is 100ms, for a hub port the delay is taken from hub descriptor

- **Super IO Configuration**

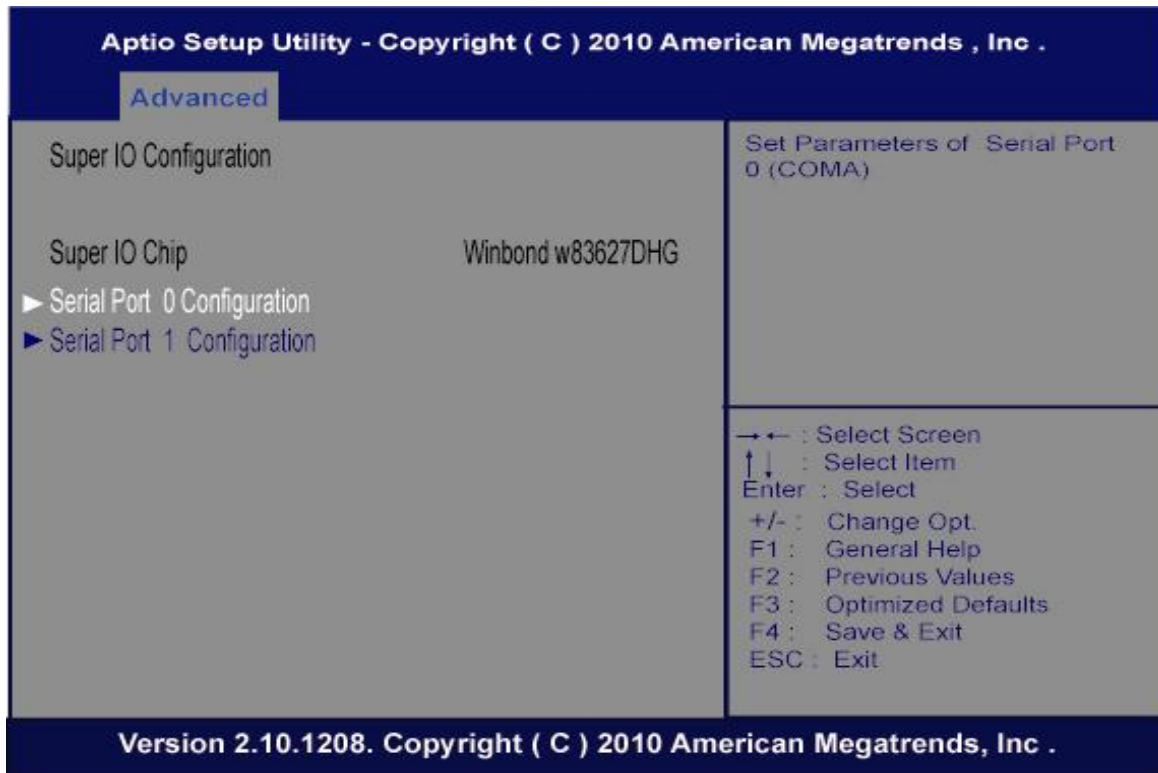

- **W83627UHG Serial Port Configuration**

The configuration of serial port 1~4 are set <Auto> as default.

- **H/W Monitor**

This screen monitors hardware health.

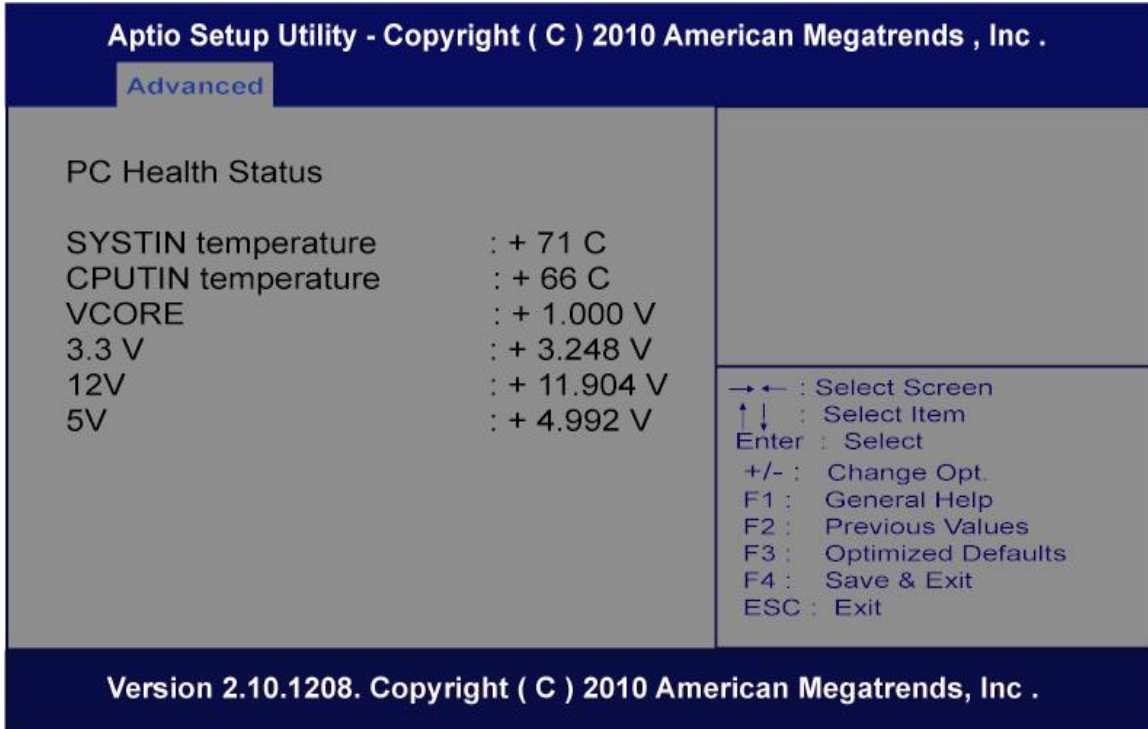

This screen displays the temperature of system and CPU, cooling fan speed in RPM and system voltages (VCORE, +12V, +5V and +3.3V).

### 3.5 Chipset Menu

The Chipset menu allows users to change the advanced chipset settings. You can select any of the items in the left frame of the screen to go to the sub menus:

- ▶ **System Agent (SA) Configuration**
- ▶ **PCH-IO Configuration**

For items marked with "▶", please press <Enter> for more options.

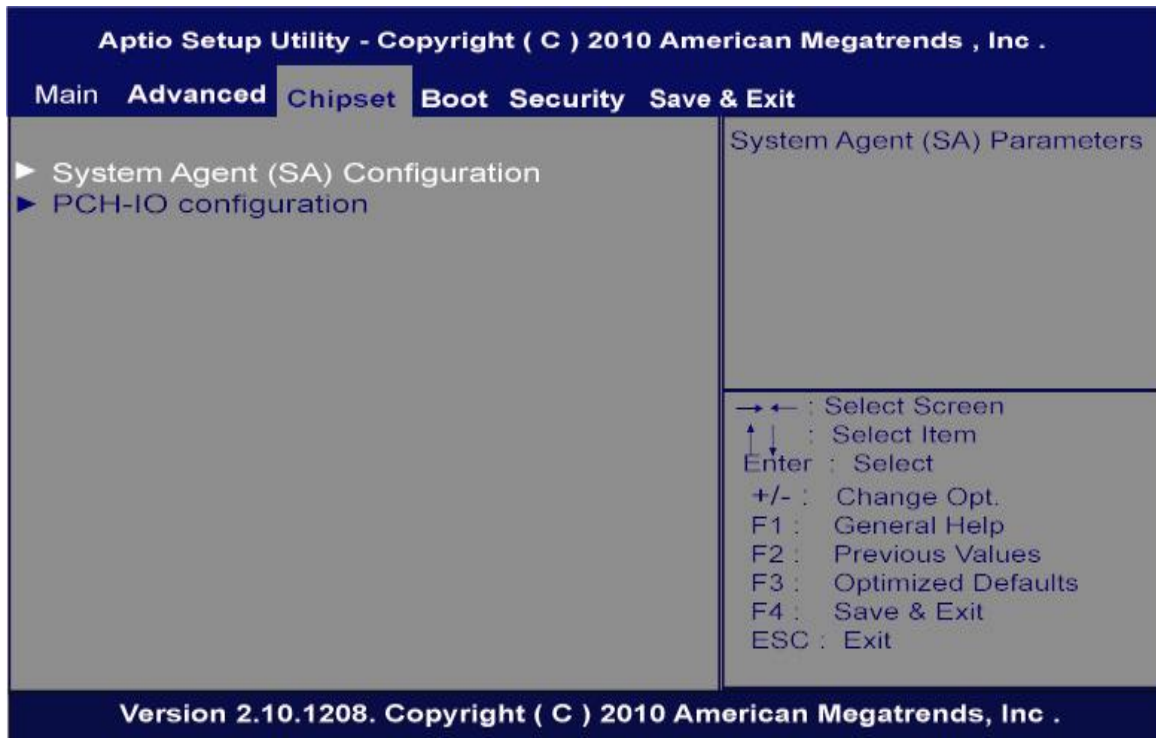

▶ **Graphics Configuration**

▶ **Memory Configuration**

For items marked with “▶”, please press <Enter> for more options.

The screenshot displays the Aptio Setup Utility interface. At the top, a dark blue header contains the text "Aptio Setup Utility - Copyright ( C ) 2010 American Megatrends , Inc .". Below this, a sub-menu titled "Chipset" is highlighted. The main area is divided into two columns. The left column lists "System Agent Version" (1.1.1.1) and "VT-d Capability" (Supported). The right column shows "Check to VT-d function on MCH." and "VT-d" (Enabled). At the bottom left, there are two menu items: "▶ Graphics Configuration" and "▶ Memory Configuration". At the bottom right, a list of navigation keys is provided: "→ ← : Select Screen", "↑ ↓ : Select Item", "Enter : Select", "+/- : Change Opt.", "F1 : General Help", "F2 : Previous Values", "F3 : Optimized Defaults", "F4 : Save & Exit", and "ESC : Exit". A footer at the bottom of the screen reads "Version 2.10.1208. Copyright ( C ) 2010 American Megatrends, Inc .".



- Graphics Configuration

**Aptio Setup Utility - Copyright ( C ) 2010 American Megatrends , Inc .**

**Chlpset**

Graphics Configuration IGFX VBIOS Version      2089 IGfX Frequency          650 MHZ		Keep IGD enabled based on the setup options.
Internal Graphics        [Auto] GTT Size                    [2MB] Aperture Size            [256MB] DVMT Pre-Allocated     [64M] DVMT Total Gfx Mem     [256M] Gfx Low Power Mode     [Enabled]		
		→ ← : Select Screen ↑ ↓ : Select Item Enter : Select +/- : Change Opt. F1 : General Help F2 : Previous Values F3 : Optimized Defaults F4 : Save & Exit ESC : Exit

**Version 2.10.1208. Copyright ( C ) 2010 American Megatrends, Inc .**

● **Memory Information**

The screenshot displays the 'Aptio Setup Utility' interface. At the top, it reads 'Aptio Setup Utility - Copyright ( C ) 2010 American Megatrends , Inc .'. Below this, a 'Chipset' tab is highlighted. The main area is divided into two sections. The left section, titled 'Memory Information', lists the following details: Memory RC Version (1.1.1.0), Memory Frequency (1.067 Mhz), Total Memory (4096 MB (DDR3)), DIMM#0 (2048 MB (DDR3)), and DIMM#1 (2048 MB (DDR3)). The right section contains a list of navigation and function keys: → ← : Select Screen, ↑ ↓ : Select Item, Enter : Select, +/- : Change Opt., F1 : General Help, F2 : Previous Values, F3 : Optimized Defaults, F4 : Save & Exit, and ESC : Exit. At the bottom of the screen, it states 'Version 2.10.1208. Copyright ( C ) 2010 American Megatrends, Inc .'.

Memory Information	
Memory RC Version	1.1.1.0
Memory Frequency	1.067 Mhz
Total Memory	4096 MB (DDR3)
DIMM#0	2048 MB (DDR3)
DIMM#1	2048 MB (DDR3)

→ ← : Select Screen  
↑ ↓ : Select Item  
Enter : Select  
+/- : Change Opt.  
F1 : General Help  
F2 : Previous Values  
F3 : Optimized Defaults  
F4 : Save & Exit  
ESC : Exit

**Aptio Setup Utility - Copyright ( C ) 2010 American Megatrends , Inc .**

**Chlpset**

PCH LAN Controller	[Disabled]	Enable or disable onboard NIC.
Azalia	[Disabled]	
Azalia Internal HDMI Codec	[Enabled]	

→← : Select Screen  
 ↑↓ : Select Item  
 Enter : Select  
 +/- : Change Opt.  
 F1 : General Help  
 F2 : Previous Values  
 F3 : Optimized Defaults  
 F4 : Save & Exit  
 ESC : Exit

**Version 2.10.1208. Copyright ( C ) 2010 American Megatrends, Inc .**

### 3.6 Boot Menu

The Boot menu allows users to change boot options of the system.

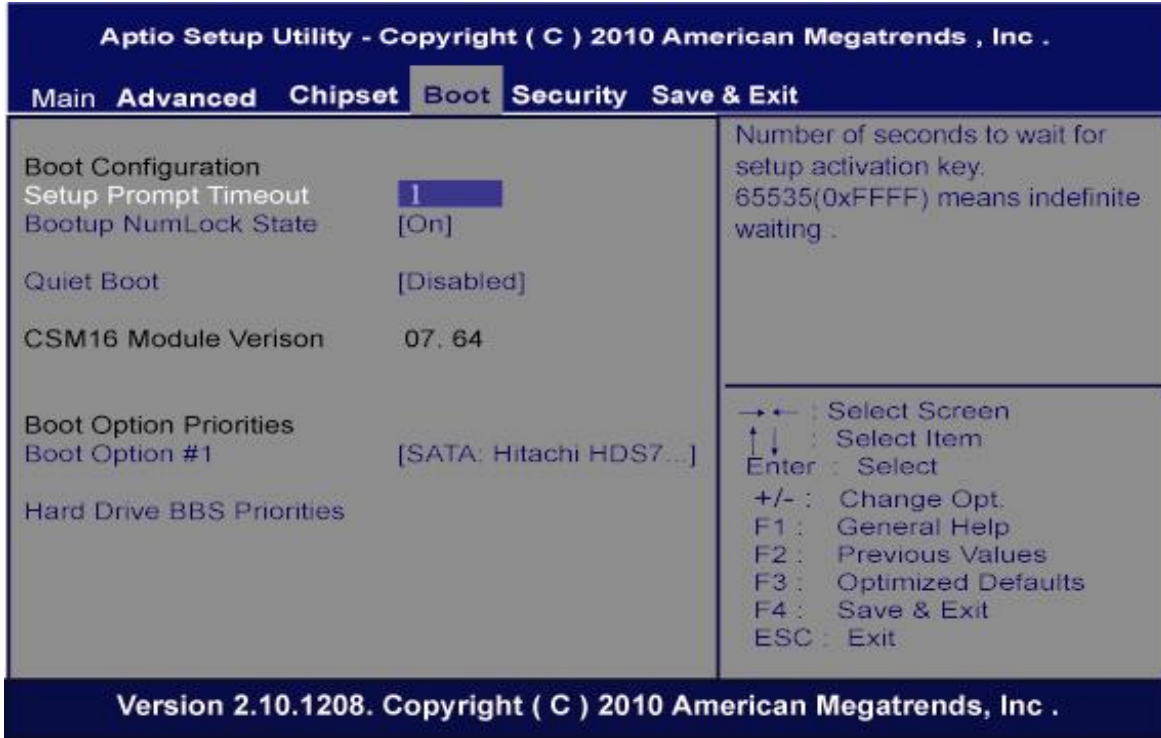

- **Setup Prompt Timeout**  
Number of seconds to wait for setup activation key. 65535 (0xFFFF) means indefinite waiting.
- **Boot up Unlock State**  
Use this item to select the power-on state for the Unlock.
- **Quiet Boot**  
Enable or disable Quiet Boot option.

### 3.7 Security Menu

The Security menu allows users to change the security settings for the system.

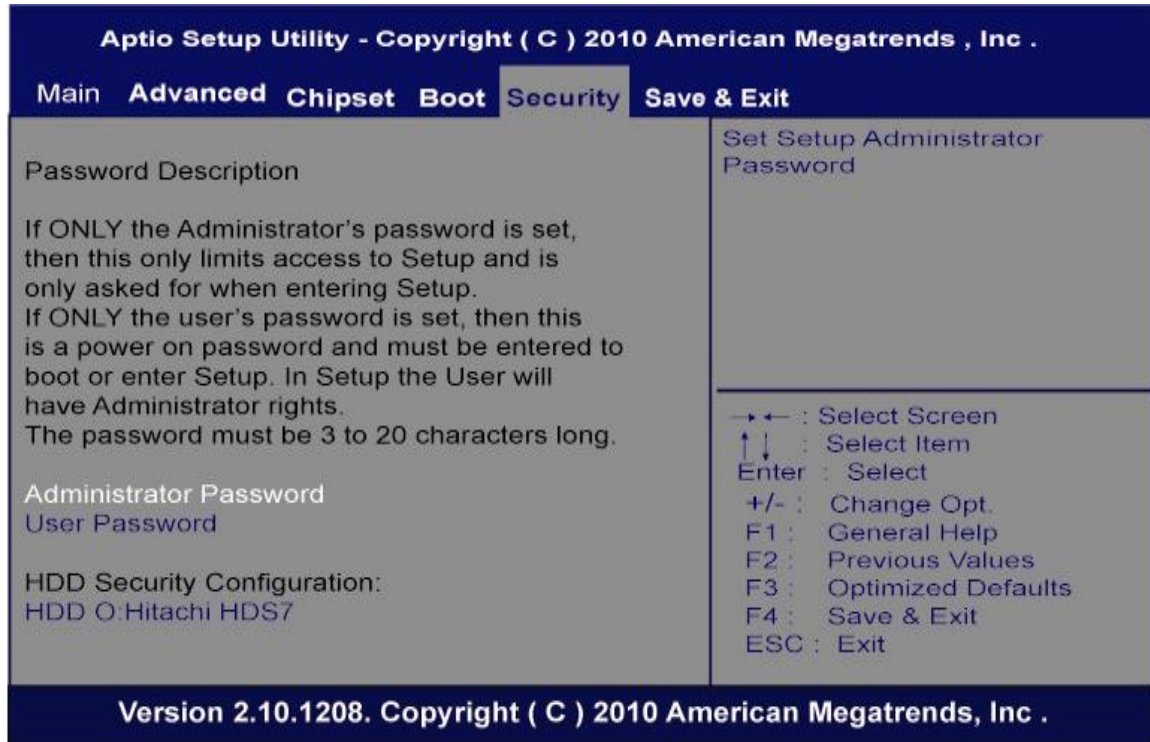

➤ **Administrator Password**

This item indicates whether an administrator password has been set (installed or uninstalled).

➤ **User Password**

This item indicates whether an user password has been set (installed or uninstalled).

### 3.8 Save & Exit Menu

The Save & Exit menu allows users to load your system configuration with optimal or fail-safe default values.

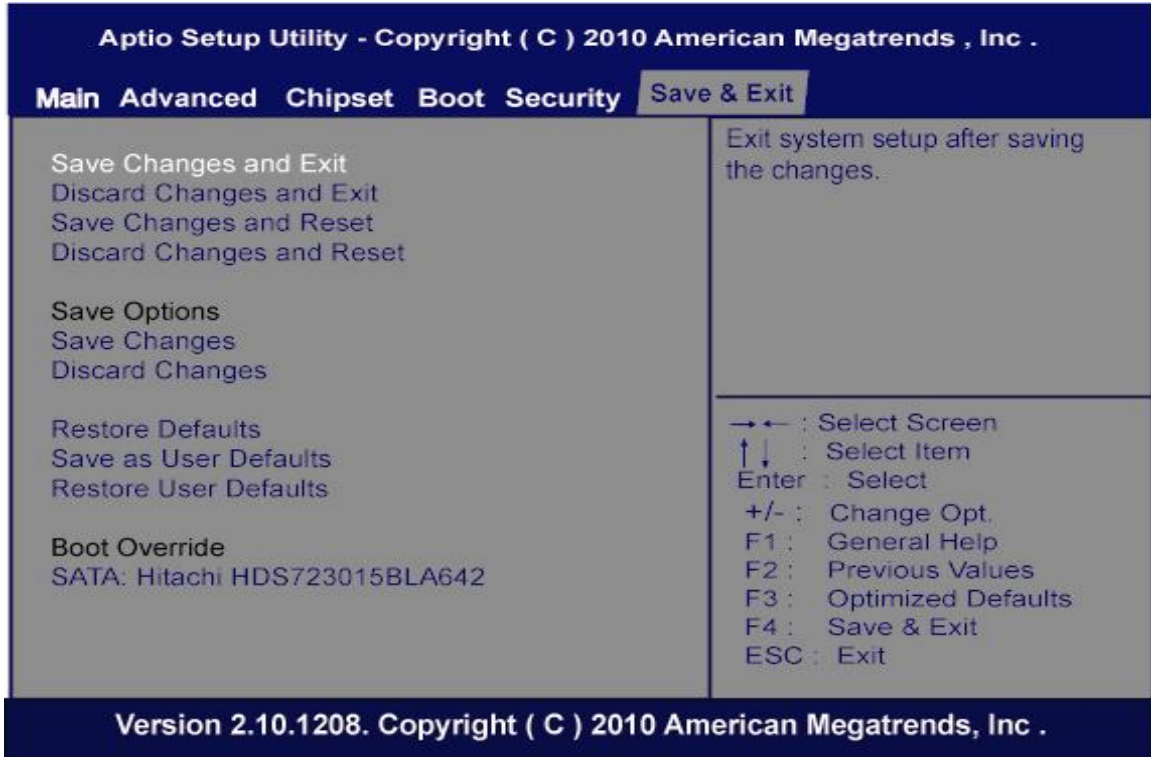

- **Save Changes and Exit**  
When finish the system configuration settings, select this option to leave Setup and return to Main Menu. Select Save Changes and Exit from the Save & Exit menu and press <Enter>. Select Yes to save changes and exit.
- **Discard Changes and Exit**  
Select this option to quit Setup without making any permanent changes to the system configuration and return to Main Menu. Select Discard Changes and Exit from the Save & Exit menu and press <Enter>. Select Yes to discard changes and exit.
- **Save Changes and Reset**  
When finish the system configuration settings, select this option to leave Setup and reboot the computer so the new system configuration parameters can take effect. Select Save Changes and Reset from the Save & Exit menu and press <Enter>. Select Yes to save changes and reset.

➤ **Discard Changes and Reset**

Select this option to quit Setup without making any permanent changes to the system configuration and reboot the computer. Select Discard Changes and Reset from the Save & Exit menu and press <Enter>. Select Yes to discard changes and reset.

➤ **Save Changes**

When finish the system configuration settings, select this option to save changes. Select Save Changes from the Save & Exit menu and press <Enter>. Select Yes to save changes.

➤ **Discard Changes**

Select this option to quit Setup without making any permanent changes to the system configuration. Select Discard Changes from the Save & Exit menu and press <Enter>. Select Yes to discard changes.

➤ **Restore Defaults**

When select this option, all the settings will be restored to defaults automatically. Select Restore Defaults from the Save & Exit menu and press <Enter>.

➤ **Save as User Defaults**

Select this option to save your current system configuration settings as User Defaults. Select Save as User Defaults from the Save & Exit menu and press <Enter>.

➤ **Restore User Defaults**

When select this option, all the settings will be restored to user defaults automatically. Select Restore User Defaults from the Save & Exit menu and press <Enter>.

**MEMO:**