

# Panasonic®

## Operating Instructions Ultra-Low Temperature Freezer MDF-U33V

## MDF-U33V Series

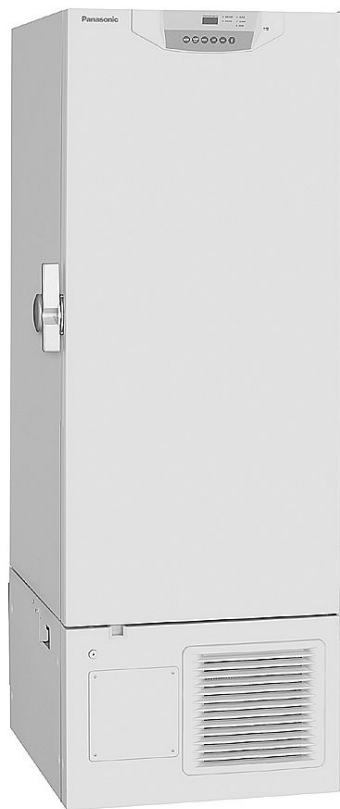

Please read these instructions carefully before using this product, and save this manual for future use.

See page 36 for all Model Nos.

# CONTENTS

INTRODUCTION	P. 2
PRECAUTIONS FOR SAFE OPERATION	P. 3
ENVIRONMENTAL CONDITIONS	P. 7
FREEZER COMPONENTS	P. 8
Control panel	P.10
INSTALLATION SITE	P.11
INSTALLATION	P.12
START-UP OF UNIT	P.13
TEMPERATURE SETTING	P.14
Key lock function	P.14
ALARM TEMPERATURE SETTING	P.15
SETTING OF ALARM RESUME TIME	P.16
REMOTE ALARM TERMINAL	P.17
MONITOR OF FREEZER STATUS	P.18
CHANGE OF COMPRESSOR DELAY TIME	P.19
CHANGE OF DOOR ALARM DELAY TIME	P.20
ALARMS & SAFETY FUNCTIONS	P.21
ROUTINE MAINTENANCE	
Cleaning of cabinet	P.22
Cleaning of condenser filter	P.22
Defrosting of inside wall	P.23
Replacement of battery	P.23
TROUBLESHOOTING	P.24
DISPOSAL OF UNIT	P.25
Recycle of battery	P.25
Decontamination of unit	P.25
DISPOSAL OF BATTERY	P.30
TEMPERATURE RECORDER[OPTION]	P.31
BACKUP COOLING KIT[OPTION]	P.33
INVENTORY RACK[OPTION]	P.34
SPECIFICATIONS	P.35
PERFORMANCE	P.36
SAFETY CHECK SHEET	P.37

---

# INTRODUCTION

---

- Read this manual carefully before using the appliance and follow the instructions for safety operation.
- Our company never guarantee any safety if the appliance is used for any objects other than intended use or used by any procedures other than those mentioned in this manual.
- Keep this manual in an adequate place to refer to it as necessary.
- The contents of the manual will be subjected to change without notice due to the improvement of performance or functions.
- Contact our sales representative or agent if any page of the manual is lost or page order is incorrect.
- Contact our sales representative or agent if any point in this manual is unclear or if there are any inaccuracies.
- No part of this manual may be reproduced in any form without the expressed written permission of our company.

 **CAUTION**

Our company guarantees the product under certain warranty conditions. Our company in no way shall be responsible for any loss of content or damage of content.

# PRECAUTIONS FOR SAFE OPERATION

**It is imperative that the user complies with this manual as it contains important safety advice.**

Items and procedures are described so that you can use this unit correctly and safely. If the precautions advised are followed, this will prevent possible injury to the user and any other person.

Precautions are illustrated in the following way:

## **WARNING**

Failure to observe WARNING signs could result in a hazard to personnel possibly resulting in serious injury or death.

## **CAUTION**

Failure to observe CAUTION signs could result in injury to personnel and damage to the unit and associated property.

Symbol shows;

 this symbol means caution.

 this symbol means an action is prohibited.

 this symbol means an instruction must be followed.

Be sure to keep this manual in a place accessible to users of this unit.

< Label on the unit >



This mark is labeled on the cover in which the electrical components of high voltage are enclosed to prevent the electric shock.













The cover should be removed by a qualified engineer or a service personnel only.

## **WARNING**

As with any equipment that uses CO<sub>2</sub> gas, there is a likelihood of oxygen depletion in the vicinity of the equipment. It is important that you assess the work site to ensure there is suitable and sufficient ventilation. If restricted ventilation is suspected, then other methods of ensuring a safe environment must be considered. These may include atmosphere monitoring and warning devices.













# PRECAUTIONS FOR SAFE OPERATION

## **WARNING**

-  **Do not use the unit outdoors.** Current leakage or electric shock may result if the unit is exposed to rain water.
-  **Only qualified engineers or service personnel should install the unit.** The installation by unqualified personnel may cause electric shock or fire.
-  **Install the unit on a sturdy floor and take an adequate precaution to prevent the unit from turning over.** If the floor is not strong enough or the installation site is not adequate, this may result in injury from the unit falling or tipping over.
-  **Never install the unit in a humid place or a place where it is likely to be splashed by water.** Deterioration of the insulation may result which could cause current leakage or electric shock.
-  **Never install the unit in a flammable or volatile location.** This may cause explosion or fire.
-  **Never install the unit where acid or corrosive gases are present** as current leakage or electric shock may result due to corrosion.
-  **Always ground (earth) the unit to prevent electric shock.** If the power supply outlet is not grounded, it will be necessary to install a ground by qualified engineers.
-  **Never ground the unit through a gas pipe, water main, telephone line or lightning rod.** Such grounding may cause electric shock in the case of an incomplete circuit.
-  **Connect the unit to a power source as indicated on the rating label attached to the unit.** Use of any other voltage or frequency other than that on the rating label may cause fire or electric shock.
-  **Never store volatile or flammable substances** in this unit if the container cannot be sealed. These may cause explosion or fire.
-  **Do not insert metal objects such as a pin or a wire into any vent, gap or any outlet on the unit.** This may cause electric shock or injury by accidental contact with moving parts.
-  **Use this unit in safe area when treating the poison, harmful or radiate articles.** Improper use may cause bad effect on your health or environment.
-  **Turn off the power switch (if provided) and disconnect the power supply to the unit prior to any repair or maintenance** of the unit in order to prevent electric shock or injury.
-  **Do not touch any electrical parts (such as power supply plug) or operate switches with a wet hand.** This may cause electric shock.

# PRECAUTIONS FOR SAFE OPERATION

## **WARNING**

-  **Ensure you do not inhale or consume medication or aerosols** from around the unit at the time of maintenance. These may be harmful to your health.
-  **Never splash water directly onto the unit** as this may cause electric shock or short circuit.
-  **Never put containers with liquid on the unit** as this may cause electric shock or short circuit when the liquid is spilled.
-  **Never bind, process, or step on the power supply cord, or never damage or break the power supply plug.** A broken supply cord or plug may cause fire or electric shock.
-  **Do not use the supply cord if its plug is loose.** Such supply cord may cause fire or electric shock.
-  **Never disassemble, repair, or modify the unit yourself.** Any such work carried out by an unauthorized person may result in fire, or electric shock or injury due to a malfunction.
-  **Disconnect the power supply plug if there is something wrong with the unit.** Continued abnormal operation may cause electric shock or fire.
-  **When removing the plug from the power supply outlet, grip the power supply plug, not the cord.** Pulling the cord may result in electric shock or fire by short circuit.
-  **Disconnect the power supply plug** before moving the unit. Take care not to damage the power cord. A damaged cord may cause electric shock or fire.
-  **Disconnect the power plug when the unit is not used for long periods.** Keeping the connection may cause electric shock, current leakage, or fire due to the deterioration of insulation.
-  If the unit is to be stored unused in an unsupervised area for an extended period, **ensure that children do not have access and that doors cannot be closed completely.**
-  **The disposal of the unit should be accomplished by appropriate personnel.** Remove doors to prevent accidents such as suffocation.
-  **Do not put the packing plastic bag within reach of children** as suffocation may result.







---

# PRECAUTIONS FOR SAFE OPERATION

---



## CAUTION

-  **Use a dedicated power source** (a dedicated circuit with a breaker) as indicated on the rating label attached to the unit. A branched circuit may cause fire resulting from abnormal heating.
-  **Connect the power supply plug to the power source firmly after removing the dust on the plug.** A dusty plug or improper insertion may cause a heat or ignition.
-  **Never store corrosive substances such as acid or alkali** in this unit if the container cannot be sealed. These may cause corrosion of inner components or electric parts.
-  **Check the setting when starting up of operation after power failure or turning off of power switch.** The stored items may be damaged due to the change of setting.
-  **Be careful not to tip over the unit** during movement to prevent damage or injury.
-  **Prepare a safety check sheet** when you request any repair or maintenance for the safety of service personnel.

---

# ENVIRONMENTAL CONDITIONS

---

This equipment is designed to be safe at least under the following conditions (based on the IEC61010-1):

- Indoor use;
- Altitude up to 2000 m;
- Ambient temperature 5°C to 40°C;
- Maximum relative humidity 80% for temperature up to 31°C decreasing linearly to 50% relative humidity at 40°C;
- Mains supply voltage fluctuations up to  $\pm 10\%$  of the nominal voltage;
- Transient overvoltages up to the levels of OVERVOLTAGE CATEGORY II;
- Temporary OVERVOLTAGES occurring on the mains supply;
- Applicable pollution degree of the intended environment (POLLUTION DEGREE 2 in most cases)



# FREEZER COMPONENTS

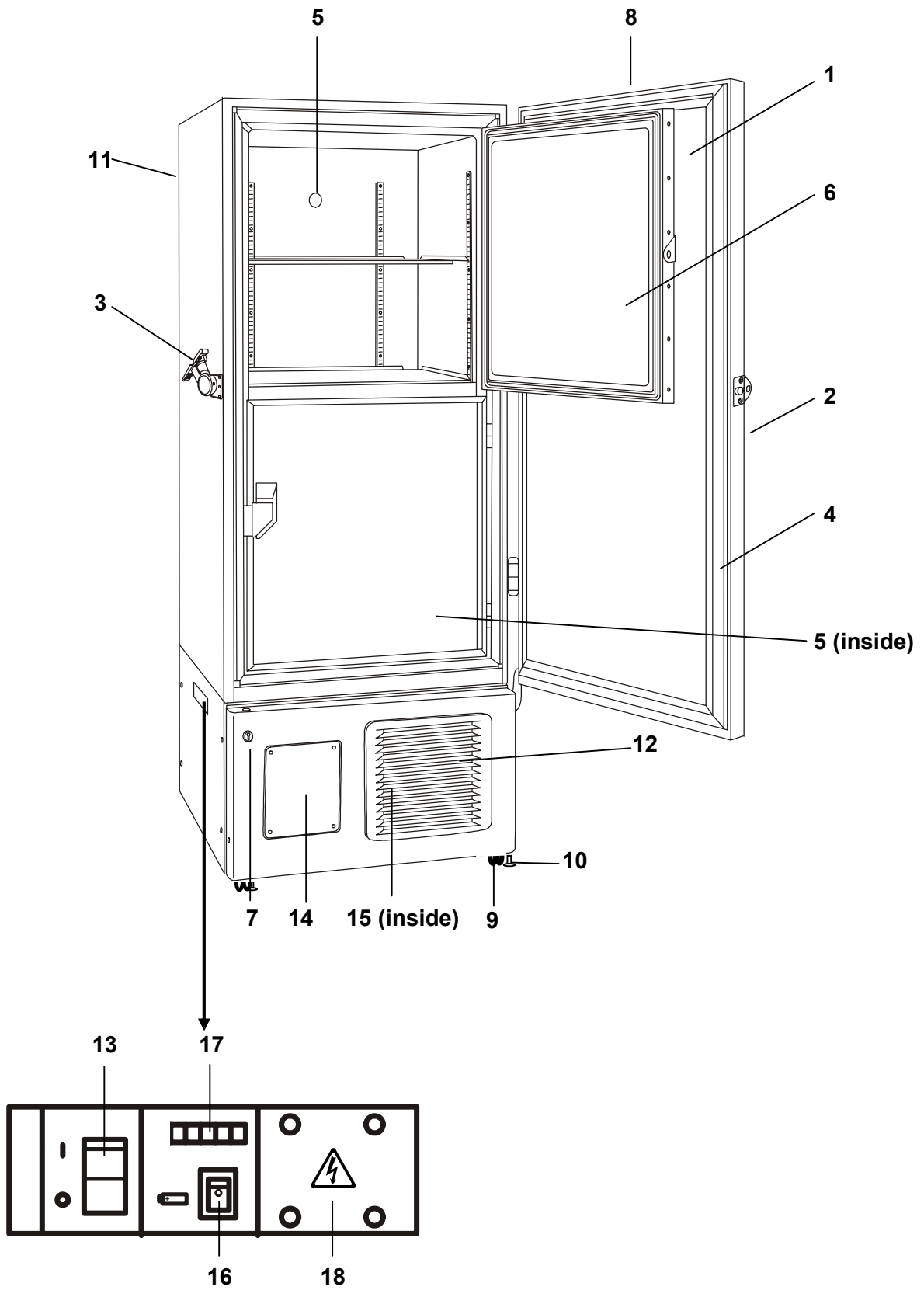

---

# FREEZER COMPONENTS

---

1. **Outer door:** To open the door, grip the handle. On closing, lock the door latch completely.
2. **Handle:** Always grip this handle to open and close the outer door.
3. **Door latch:** Always lock the latch when the outer door is closed.
4. **Magnetic door gasket:** This provides a tight door seal and prevents cold air leak. Keep clean.
5. **Access port (back and bottom):** This is used for leading a cable and sensor of a measuring equipment, or nozzle of backup cooling kit to chamber.
6. **Inner door:** The operation of the inner door should be quick to minimize the temperature rise in chamber. Lock the door latch completely when the door is closed. The door is removable for cleaning or defrosting. See page 23 "Routine maintenance".
7. **Lock:** Turn clockwise to 180° with a key and the outer door is securely locked.
8. **Control panel (on the upper front of the door):** Used for temperature setting and indication of operating status is displayed on the panel. See page 10 for details.
9. **Caster:** 4 casters are provided to facilitate moving of the cabinet. For the installation, adjust the leveling foot so that the front 2 casters cannot contact with the floor.
10. **Leveling foot:** The height of the freezer can be adjusted by this screw type foot. Keep the unit in level at the installation.
11. **Fixture (on back side):** 2 fixtures are provided as spacers between the cabinet and wall and also serve as hooks to fix the unit. See page 12 "Installation".
12. **Air intake vent (grille):** Do not block this vent to keep the proper cooling performance.
13. **Power switch:** This is for turning ON/OFF the power to the unit. ON – "I" OFF – "O"
14. **Space for temperature recorder:** An automatic temperature recorder (optional component) can be attached here. See page 31 "Temperature recorder".
15. **Condenser filter (behind the grille):** This filter prevents the dust from accumulating on the condenser. The dusty filter may cause failure of refrigerating device. Clean the filter once a month. See page 22 "Routine maintenance" for the cleaning.
16. **Battery switch:** This is a switch for a battery for power failure alarm. Normally, turn on this switch. Be sure to turn off this switch if the freezer is not in operating for the long period (over one month).
17. **Remote alarm terminal:** This is used to notice an alarm condition of the unit to remote location. Refer to page 17 "Remote alarm terminal".
18. **Space for optional component:**

# FREEZER COMPONENTS

## Control panel

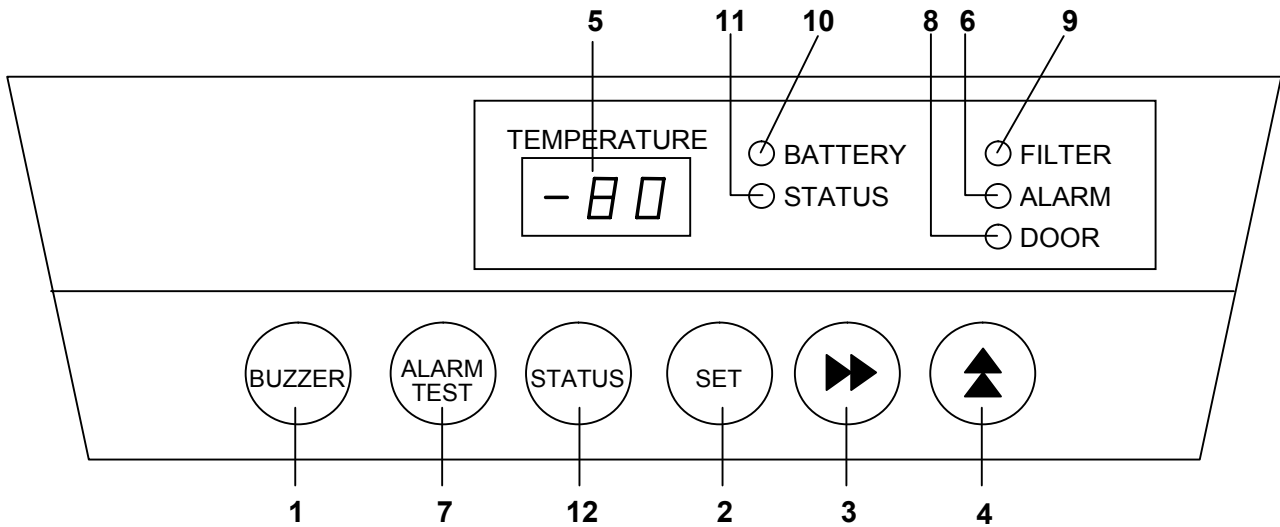

**1. Buzzer stop key (BUZZER):** To silence the audible alarm under alarm condition, press this key. The buzzer during alarm test cannot be silenced by this key.

**2. Set key (SET):** Temperature setting mode is led by pressing this key and the changeable digit is flashed. By pressing this key again, the setting is memorized. The set mode returns to the temperature display mode automatically when 90 seconds has passed without any key operation. Refer to page 14 for details.

**3. Digit shift key (▶▶):** Pressing this key in the setting mode causes the changeable digit to shift. Key lock is available by pressing this key for more than 5 seconds in the temperature display mode. Refer to page 14 for details.

**4. Numerical value shift key (▲):** Pressing this key in the setting mode causes the numerical value to shift. "ON-OFF" of key lock can be selected by pressing this key in the key lock mode. By pressing this key for more than 5 seconds in the temperature display mode leads setting mode for alarm temperature and alarm resume time. Refer to page 15 and 16 for details respectively.

**5. Digital temperature indicator:** This indicator shows the present chamber temperature or set temperature.

**6. Alarm lamp (ALARM):** This lamp is flashed during alarm condition.

**7. Alarm test key (ALARM TEST):** To check the alarm system during freezer operation. Pressing this key with the battery switch ON gets the alarm lamp to flash, the remote alarm to operate, and the buzzer to sound.

**8. Door check lamp (DOOR):** This lamp lights when the door is open.

**9. Filter check lamp (FILTER):** This lamp lights when the excessive dust is accumulated on the condenser filter. When this lamp lights, clean the condenser filter following the procedure on page 22.

**10. Battery check lamp (BATTERY):** This lamp flickers to recommend the battery replacement. For the replacement, consult our sales representative or agent.

**11. Status monitor lamp (STATUS):** This lamp lights when environmental condition or status gets worse or the unit is out of normal operation.

**12. Status key (STATUS):** By pressing this key in the event of the status monitor lamp ON, the status code is displayed on the temperature indicator. This key is not effective when the freezer is running normally. See page 18 for details.

# INSTALLATION SITE

To operate this unit properly and to obtain maximum performance, install the unit in a location with the following conditions:

■ **A location not subjected to direct sunlight**

Do not install the unit under direct sunlight. Installation in a location subjected to direct sunlight cannot obtain the intended performance.

■ **A location with adequate ventilation**

Leave at least 10 cm around the unit for ventilation. Poor ventilation will result in a reduction of the performance and consequently the failure.

■ **A location away from heat generating sources**

Avoid installing the unit near heat-emitting appliances such as a heater or a boiler etc. Heat can decrease the intended performance of the unit.

■ **A location with little temperature change**

Install the unit under stable ambient temperature. The allowable ambient temperature is between +5 and +30°C.

■ **A location with a sturdy and level floor**

Always install the unit on a sturdy and level floor. The uneven floor or tilted installation may cause failure or injury. Install the unit in stable condition to avoid the vibration or noise. Unstable condition may cause vibration or noise.

 **WARNING**

**Install the unit on a sturdy floor.** If the floor is not strong enough or the installation site is not adequate, this may result in injury from the unit falling or tipping over.

**Select a level and sturdy floor for installation.** This precaution will prevent the unit from tipping. Improper installation may result in water spillage or injury from the unit tipping over.

■ **A location not prone to high humidity**

Install the unit in the ambient of 80% R.H. or less humidity. Installation under high humidity may cause current leakage or electric shock.

 **WARNING**

**Do not use the unit outdoors.** Current leakage or electric shock may result if the unit is exposed to rain water.

**Never install the unit in a humid place or a place where it is likely to be splashed by water.** Deterioration of the insulation may result which could cause current leakage or electric shock.

■ **A location without flammable or corrosive gas**

Never install the unit in a flammable or volatile location. This may cause explosion or fire or may result in the current leakage or electric shock by the corrosion of the electrical components.

■ **A location without the possibility of anything fall**

Avoid installing the unit in the location where anything can fall down onto the unit. This may cause the breakdown or failure of the unit.

# INSTALLATION

## 1. Removing the packaging materials and tapes

Remove all transportation packaging materials and tapes. Open the doors and ventilate the unit. If the outside panels are dirty, clean them with a diluted neutral dishwashing detergent. (Undiluted detergent can damage the plastic components. For the dilution, refer to the instruction of the detergent.) After the cleaning with the diluted detergent, always wipe it off with a wet cloth. Then wipe off the panels with a dry cloth.

### Note:

Remove the cable tie banding the power supply cord. Prolonged banding may cause the corrosion of the cord coating.

## 2. Adjusting the leveling foot

Extend the leveling feet by rotating them counterclockwise to contact them to the floor. Ensure the unit is level. (Fig. 1)

## 3. Fixing the unit

Two fixtures are attached to the rear of the frame. Fix the frame to the wall with these fixtures and rope or chain. (Fig. 2)

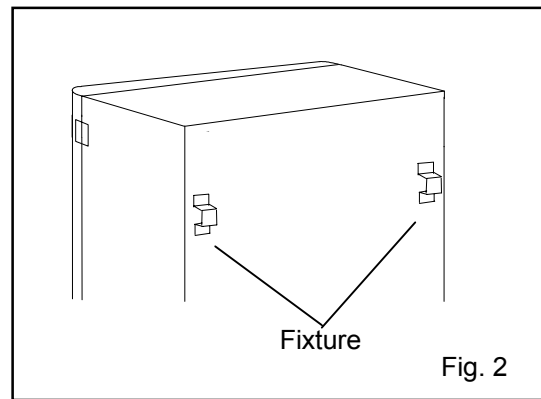
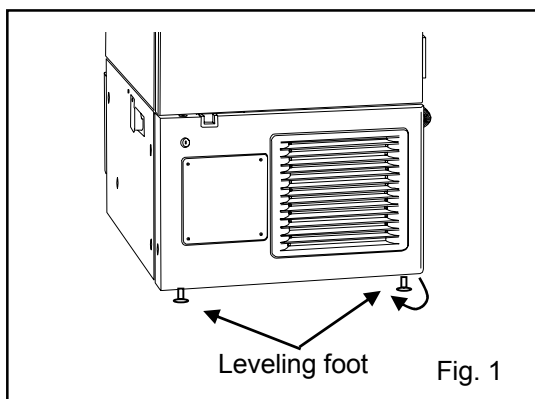

## 4. Ground (earth)

The ground (earth) is for preventing the electric shock in the case of the electrical insulation is somehow degraded. Always ground the unit at the time of installation.

### **⚠️ WARNING**

**Use a power supply outlet with ground (earth) to prevent electric shock.** If the power supply outlet is not grounded, it is necessary to install a ground by qualified engineers.

**Never ground the unit through a gas pipe, water main, telephone line or lightning rod.** Such grounding may cause electric shock in the case of an incomplete circuit.

---

# START-UP OF UNIT

---

Follow the procedures for the initial and consequent operations of the unit.

1. Connect the power cord to the dedicated outlet having appropriate rating with the chamber empty, and turn on the power switch on the freezer.
2. Turn off the switch of the backup cooling kit (optional component) if it is installed.
3. Check that the battery switch is ON.
4. The audible alarm may be activated. In this case, press the buzzer stop key (BUZZER) to silence the alarm.
5. Set the desired chamber temperature. See page 14 for the temperature setting.
6. Check that the chamber temperature reaches the desired temperature.
7. Turn on the switch of the backup cooling kit (optional component) if it is installed.
8. Make sure that the alarm lamp blinks and the buzzer sounds by pressing the alarm test key (ALARM TEST).
9. After confirming the above, you can put articles into the freezer chamber in a small batch to prevent the temperature rise.

**Note:**

- When you start the unit at low ambient temperature the unit is programmed to repeatedly turn on and off the compressor in order to make its startability better. (115 V 60 Hz only)

**Operation after power failure**



The set value is memorized by nonvolatile memory. Accordingly, the freezer resumes the operation with setting before power failure.

# TEMPERATURE SETTING

Table 1 shows the basic procedure for setting the chamber temperature. Perform key operations in the sequence indicated in the table. The example in the table is based on the assumption that the desired temperature is -75°C.

**Note:** The unit is set at the factory that the chamber temperature -80°C.

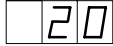
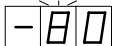
**Table 1. Basic operation sequence (Example: Chamber temperature -75°C)**

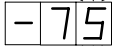
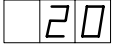
	Description of operation	Key operated	Indication after operation
1	Turn the power switch ON.	----	The current chamber temperature is displayed. 
2	Press set key.	SET	The second digit is flashed. 
3	Set to -75 with the numerical value shift key and digit shift key.		When pressed, the figure of settable digit changes.
			When pressed, the settable digit is shifted. 
4	Press set key.	SET	Set temperature is memorized and the current chamber temperature is displayed. 

**Note:**







- The temperature set mode returns to the temperature display mode automatically when 90 seconds has passed without any key operation.
- Although the value of the chamber temperature setting can range from -50°C to -90°C, the guaranteed temperature with no load is -86°C when the ambient temperature is 30°C.

## Key lock function

This unit is provided with the key lock function. When the key lock is ON, change of temperature setting through the key pad is not possible. The key lock is set to OFF at the factory.

Display	Mode	Function
L 0	Key lock is OFF	Enable to change temperature setting
L 1	Key lock is ON	Disable to change temperature setting

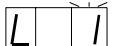
**Table 2. Procedure for key lock setting (change from key lock OFF to key lock ON)**

	Description of operation	Key operated	Indication after operation
1		----	The current chamber temperature is displayed. 
2	Press digit shift key for 5 seconds.		The first digit is flashed. 
3	Press numerical value shift key and scroll the figure to 1.		When pressed, the figure of settable digit changes. 
4	Press set key.	SET	The key lock is set to ON. The current chamber temperature is displayed. 

# ALARM TEMPERATURE SETTING

This unit is provided with the high and low temperature alarm and the temperature at which the alarm is activated is changeable.

The following procedure shows the setting of alarm temperature according to the condition below:

High temperature alarm: activates at the temperature 5°C higher than the set temperature

Low temperature alarm: activates at the temperature 5°C lower than the set temperature

**Note:**

The alarm temperature is set at the factory 10°C higher and lower than the set temperature.

The available range of alarm temperature is between 5°C and 20°C higher or lower than the set temperature.

**Table 3. Procedure for setting high temperature alarm**

	Description of operation	Key operated	Indication after operation
1		----	The current chamber temperature is displayed.
2	Press numerical value shift key for about 5 seconds.		The first digit is flashed.
3	Press numerical value shift key and scroll the figure to 1.		The first digit is flashed.
4	Press set key.	SET	The first digit is flashed.
5	Scroll the figure to 005 by using digit shift key and numerical value shift key		When pressed, the figure of settable digit changes.
			When pressed, the changeable digit moves.
6	Press set key.	SET	Alarm temperature is memorized and the current chamber temperature is displayed.

**Table 4. Procedure for setting low temperature alarm**

	Description of operation	Key operated	Indication after operation
1		----	The current chamber temperature is displayed.
2	Press numerical value shift key for about 5 seconds.		The first digit is flashed.
3	Press numerical value shift key and scroll the figure to 2..		The first digit is flashed.
4	Press set key.	SET	The first digit is flashed.
5	Scroll the figure to -05 by using digit shift key and numerical value shift key		When pressed, the figure of settable digit changes.
			When pressed, the changeable digit moves.
6	Press set key.	SET	Alarm temperature is memorized and the current chamber temperature is displayed.



# SETTING OF ALARM RESUME TIME

The alarm buzzer is silenced by pressing buzzer stop key (BUZZER) on the control panel during alarm condition (The remote alarm is not silenced).

The buzzer will be activated again after certain suspension if the alarm condition is continued. The suspension time can be set by following the procedure shown in the Table 5 below.

The example in the table is based on the assumption that the desired duration is 20 minutes.

**Note:** The duration is set in 30 minutes at the factory.

**Table 5. Setting procedure for alarm resume time (change from 30 minutes to 20 minutes)**

	Description of operation	Key operated	Indication after operation
1		----	The current chamber temperature is displayed.
2	Press digit shift key for 5 seconds.		The first digit is flashed.
3	Set the figure to F25 with the digit shift key and numerical value shift key.		The settable digit is shifted.
			When pressed, the figure of settable digit changes.
4	Press set key.	SET	The current resume time is displayed. The middle digit is flashed.
5	Set the figure to 020 with the numerical value shift key.		When pressed, the figure of settable digit changes.
6	Press set key.	SET	The setting is memorized and the current chamber temperature is displayed.

- The settable alarm resume time is 10, 20, 30, 40, 50, or 60 minutes (The setting is 010, 020, 030, 040, 050, or 060). The buzzer would not resume if the resume time is set in 000.
- It is recommended to set the alarm resume time when the freezer is not under alarm condition. The setting during alarm condition is effective on the next alarm condition.
- The setting cannot be changed during power failure.
- The remote alarm during power failure or buzzer and remote alarm during alarm test cannot be silenced.
- The set mode returns to the temperature display mode automatically when 90 seconds has passed without any key operation. In this case, any setting before pressing set key(SET) is not memorized.

# REMOTE ALARM TERMINAL

The terminal of the remote alarm is installed at the lower left side of the unit. The alarm is outputted from this terminal. Contact capacity is DC 30 V, 2 A.

Contact output:

	between COM. and N.O.	between COM. and N.C.
At normal	Open	Close
At abnormal	Close	Open

**Note:**

The alarm is actuated when the power cord is disconnected from the outlet or the power switch is OFF.

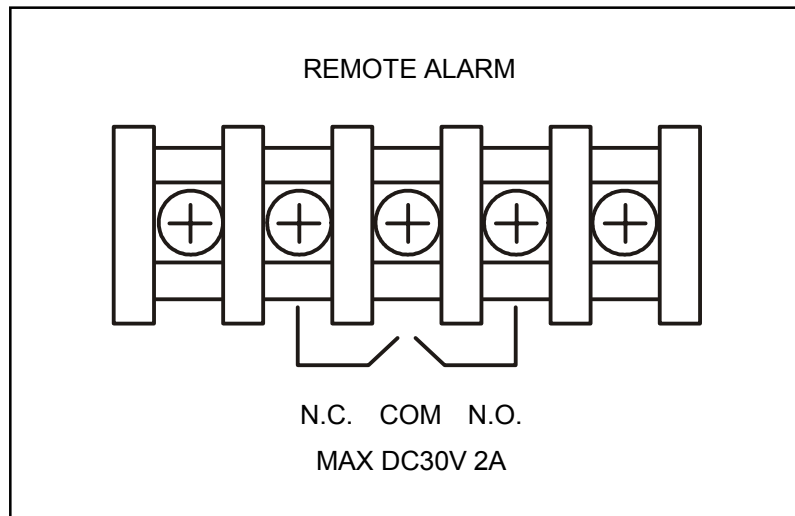

# MONITOR OF FREEZER STATUS

The freezer has a function to monitor the running status of the unit as shown in table 6 below. This is to notice the running status getting worse (not failure).

1. The STATUS lamp is lit when one of the running status shown in table 6 is detected.
2. The S code (--X, X: 1 to 3) is displayed on the temperature indicator by pressing STATUS key when the STATUS lamp is lit.
3. Pressing the STATUS key again returns to current chamber temperature on the temperature indicator. (The indication returns to the chamber temperature display automatically when no key is operated for 90 seconds.)

**Table 6. Monitor of running status**

Kind of function	Status	Indication	If this status continues	Remedy
Notice of abnormal ambient temperature	When the ambient temp. is over approx. 35°C or lower than about 0°C.	STATUS lamp lights. "--1" is displayed.	Decrease of cooling performance or durability of refrigerating circuit.	Recheck air-conditioning of installed site.
Notice of low voltage	When the power source voltage is less than approx. 97 V when the rated voltage is 115 V.	STATUS lamp lights. "--2" is displayed.	Abnormal heat at power supply outlet or degrade of starting performance of refrigerating circuit	Use dedicated power source.
Notice of overload condition	When the running rate of refrigerating Circuit is higher than usual.	STATUS lamp lights. "--3" is displayed.	Decrease of cooling performance or durability of refrigerating circuit.	1. This is likely to happen when a large amount of materials is stored. 2. Check ambient temp., voltage, and sealing of outer/inner door.

**Note:**

- The S code displayed on the temperature indicator is changed every few seconds if two or three status shown in the above table are detected at the same time. (--1 ⇒ --2 ⇒ --3 ⇒ --1 repeated)
- The monitoring function does not trigger a buzzer or conduct a safety operation.
- In the case of multiple indication of S code, follow the remedy for each status.

# CHANGE OF COMPRESSOR DELAY TIME

The delay time of high and low stage side compressor can be changed to reduce the load on the power line and to facilitate the start-up (reset) of the freezer after power failure.

The example in the table is based on the assumption that the delay time is changed to 4 minutes. (The delay time is set in 2 minutes at the factory.)

**Note:**

- The delay time should be the same for high stage side and low stage side compressors.
- The setting range for delay time is between 2 and 15 minutes. The cool down of chamber temperature may be slow when the setting of delay time is over 5 minutes, depending on the installation environment. There is no need of changing the delay time when the capacity of power source is adequate.

**Table 7. Changing procedure for delay time (change from 2 minutes to 4 minutes)**

	Description of operation	Key operated	Indication after operation
1		----	The current chamber temperature is displayed.
2	Press numerical value shift key for 5 seconds.		The first digit is flashed.
3	Set the figure to F05 with the numerical value shift key.		When pressed, the figure of settable digit changes.
4	Press set key.	SET	The current delay time is displayed. The first digit is flashed.
5	Set the figure to 004 with the numerical value shift key.		When pressed, the figure of the first digit changes.
6	Press set key.	SET	The delay time is memorized and the current chamber temperature is displayed.

- The compressor starts to operate with the delay time set by the above procedure at the time of power on or after power failure. However, the start up of the low stage side compressor is affected by the chamber temperature and the cascade condenser temperature. The delay time varies depending on how they meet the start up conditions.

# CHANGE OF DOOR ALARM DELAY TIME

The buzzer of door alarm is activated with 2 minutes delay when the door is open. The delay time is changeable.

Follow the procedure in table 8 below to change the setting of delay time. The procedure assumes that the delay time is changed from 2 minutes to 3 minutes.

(The delay time is set in 2 minutes at the factory.)

**Table 8. Changing procedure for delay time (change from 2 minutes to 3 minutes)**

	Description of operation	Key operated	Indication after operation
1		----	The current chamber temperature is displayed.
2	Press numerical value shift key for 5 seconds.	▲	The first digit is flashed.
3	Set the figure to F04 with the numerical value shift key.	▲	When pressed, the figure of settable digit changes.
4	Press set key.	SET	The current delay time is displayed. The first digit is flashed.
5	Set the figure to 003 with the numerical value shift key.	▲	When pressed, the figure of the first digit changes.
6	Press set key.	SET	The delay time is memorized and the current chamber temperature is displayed.

**Note:**

- The setting range for delay time is between 1 and 15 minutes.

# ALARMS & SAFETY FUNCTIONS

This unit has the alarms and safety functions shown in Table 9, and also self diagnostic functions.

**Table 9. Alarms and safety functions**

Alarm & Safety	Situation	Indication	Buzzer	Safety operation
High temperature alarm	If the chamber temperature is higher than the temperature at which the high temperature alarm is activated.	Alarm lamp is flashed. Temperature indicator is flashed.	Intermittent tone with 15 minutes delay.	Remote alarm with 15 minutes delay.
Low temperature alarm	If the chamber temperature is lower than the temperature at which the low temperature alarm is activated.			
Power failure alarm	When the power to the unit is disconnected.	Alarm lamp is flashed.	Intermittent tone	Remote alarm.
Door alarm	When the door is open.	Door check lamp lights.	Intermittent tone with 2minutes delay.	-----
Filter check	When the condenser filter is clogged.	Filter check lamp lights.	-----	-----
Battery check	When about 2.8 years has passed with power switch ON.	Battery check lamp lights.	-----	-----
Auto-return	When there is no key pressing in each setting mode for 90 seconds.	Chamber temperature is displayed.	-----	Finishing of each setting mode.
Key lock	When the key lock is "ON".	-----	-----	Change of setting is disable.
Sensor abnormality	If the thermal sensor is disconnected.	Alarm lamp is flashed. E01 and chamber temp. are displayed alternately.	Intermittent tone	Remote alarm. Unit keeps continuous running.
	If the thermal sensor is short-circuited.	Alarm lamp is flashed. E02 and chamber temp. are displayed alternately.	Intermittent tone	Remote alarm. Unit keeps continuous running.
	If the cascade sensor is disconnected.	Alarm lamp is flashed. E03 and chamber temp. are displayed alternately.	Intermittent tone	Remote alarm.
	If the cascade sensor is short circuited.	Alarm lamp is flashed. E04 and chamber temp. are displayed alternately.	Intermittent tone	Remote alarm.
	If the filter sensor is disconnected.	Alarm lamp is flashed. E05 and chamber temp. are displayed alternately.	Intermittent tone	Remote alarm.
	If the filter sensor is short-circuited.	Alarm lamp is flashed. E06 and chamber temp. are displayed alternately.	Intermittent tone	Remote alarm.
	If the ambient temperature sensor is disconnected.	Alarm lamp is flashed. E07 and chamber temp. are displayed alternately.	Intermittent tone	Remote alarm.
	If the ambient temperature sensor is short-circuited.	Alarm lamp is flashed. E08 and chamber temp. are displayed alternately.	Intermittent tone	Remote alarm.
Battery switch check	When the battery switch is OFF during alarm test.	Alarm lamp is flashed. E09 is flashed.	-----	-----
Condenser temp. abnormality	In the event of failure of fan motor for cooling the compressor	E10 and chamber temp. are displayed alternately.	Intermittent tone	Remote alarm. Compressor of high stage side stops.

**Note:**

- When the operation is started in high ambient temperature, the filter check lamp sometimes lights. In this case, the lamp is off automatically when the chamber temperature is getting lower.
- The freezer resumes the operation after power failure with the temperature setting before power failure as the chamber temperature setting and alarm temperature setting are memorized in the nonvolatile memory.
- The chamber temperature is displayed for 5 seconds by pressing buzzer stop key (BUZZER) during power failure alarm. Then the buzzer is silenced. The alarm lamp keeps flashing.

# ROUTINE MAINTENANCE

## **⚠ WARNING**

**Always disconnect the power supply to the unit prior to any repair or maintenance** of the unit in order to prevent electric shock or injury.

**Ensure you do not inhale or consume medication or aerosols** from around the unit at the time of maintenance. These may be harmful to your health.

## **Cleaning of cabinet**

- Clean the unit once a month. Regular cleaning keeps the unit looking new.
- Use a dry cloth to wipe off small amounts of dirt on the outside and inside of the unit and all accessories. If the outside panels are dirty, clean them with a diluted neutral dishwashing detergent. (Undiluted detergent can damage the plastic components. For the dilution, refer to the instruction of the detergent.) After the cleaning with the diluted detergent, always wipe it off with a wet cloth. Then wipe off the cabinet or accessories with a dry cloth.
- Never pour water onto or into the unit. Doing so can damage the electric insulation and cause failure.
- The compressor and other mechanical parts are completely sealed. This unit requires absolutely no lubrication.
- Check the backup cooling kit by pressing TEST switch once a month if it is installed.
- Remove the frost or ice on the chamber wall and clean the condenser filter once a month.

## **Cleaning of condenser filter**

This unit is provided with the filter check lamp on the control panel. Clean the filter when this lamp lights. Clean the filter once a month even if the check lamp is not on since a clogged filter may cause shorter compressor life as well as the poor cooling.

Clean the filter by the procedure below.

1. Open the grille by pulling it to you as shown in the figure.
2. Take out the condenser filter.
3. Wash the filter with water.
4. Replace the filter and the grille.
5. Check that the filter check lamp is off in the event the check lamp was ON.

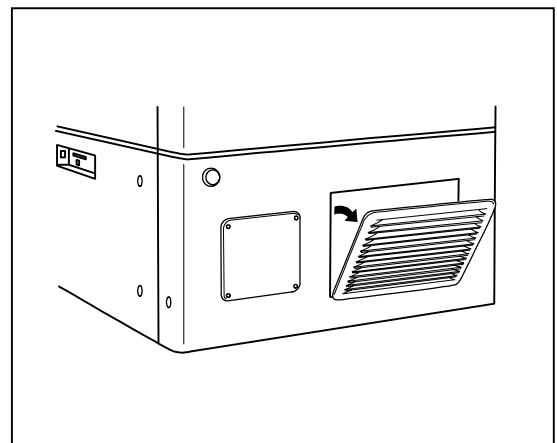

## **⚠ WARNING**

**Do not touch the condenser directly** when the filter is removed for cleaning. This may cause injury by hot surface.

# ROUTINE MAINTENANCE

## Defrosting of inside wall

The frost is built at the upper portion of the chamber and inner door. The excessive frost possibly make some gap between the cabinet and door gasket, which may cause poor cooling. Remove the frost on the inner door with a scraper enclosed with the unit. Following shows the procedure for removing the chamber frost.

**Note:** For removing the frost, do not use a tool with sharp edge such as a knife or a screw driver.

1. Turn off the backup cooling kit if applicable.
2. Take out and transfer all the contents to another freezer or a container which is refrigerated by liquid carbon dioxide or dry ice.
3. Turn off the power switch of the freezer.
4. Open the outer door and inner door. Remove the inner door by lifting up as shown in the figure.
5. Leave the freezer as it is.
6. The water accumulated on the bottom of the chamber should be wiped up with a dry cloth.
7. After cleaning the chamber and inner door, replace the inner door and start up the unit according to the procedure on page 13.
8. Put back the articles into the sufficiently cooled freezer compartment.
9. Turn on the backup cooling kit if it is provided.

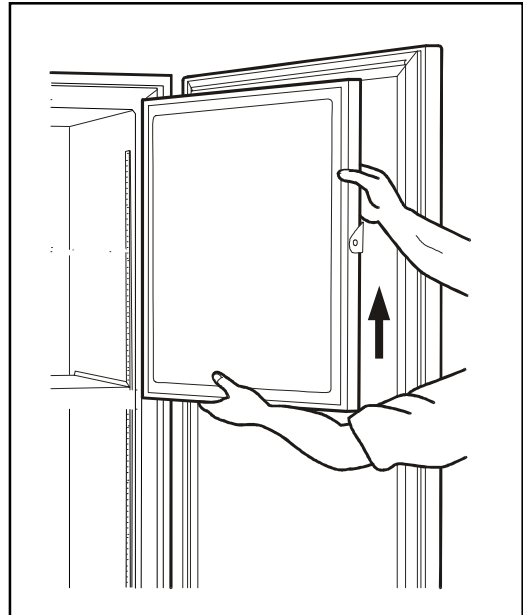

## Replacement of battery

The battery for power failure alarm is an article for consumption. The battery life is approximately 3 years. The buzzer can not be activated at the power failure and the stored items may be influenced if the battery is left as it is for more than 3 years. It is recommended that the battery is replaced ahead of time. For the replacement of the battery, contact our sales representative or agency.



# TROUBLE SHOOTING

If the unit malfunctions, check out the following before calling for service.

Malfunction	Check/Remedy
The chamber is not cooled at all	<ul style="list-style-type: none"> <li>▪ The circuit breaker of power source is active.</li> <li>▪ The voltage is too low. (The status code "--2" is displayed. See page 18.) In this case, call an electrician.</li> <li>▪ The power switch is not ON.</li> <li>▪ The large amount of articles (load) is stored in the chamber at one time. (The status code "--3" is displayed. See page 18.)</li> </ul>
The cooling is poor	<ul style="list-style-type: none"> <li>▪ The ambient temperature is too high. (The status code "--1" is displayed. See page 18.)</li> <li>▪ The latch of inner door is not closed completely. The outer door is not closed firmly. (The frost or ice between the cabinet and door gasket possibly prevents door seal.)</li> <li>▪ The air intake vent is blocked.</li> <li>▪ The condenser filter is clogged. Always clean the filter when the filter check lamp is lit.</li> <li>▪ The set temperature is not inputted properly.</li> <li>▪ The freezer is not away from the direct sunlight.</li> <li>▪ There is any heating source near the freezer.</li> <li>▪ A rubber cap and insulation for the access port are not set correctly.</li> <li>▪ You put too many unfrozen articles into the freezer compartment.</li> </ul>
Alarm test key cannot actuate the alarm	<ul style="list-style-type: none"> <li>▪ The alarm is activated only when the power switch is ON.</li> <li>▪ When only the buzzer or only the alarm is actuated by the alarm test key, the unactuated part is out of order, and must be replaced.</li> </ul>
Noise	<ul style="list-style-type: none"> <li>▪ The freezer is not installed on the sturdy floor.</li> <li>▪ There is anything touching the frame.</li> <li>▪ The freezer is not leveled with the leveling feet.</li> <li>▪ The freezer is in the status immediately after start up.</li> </ul> <p>The unit sometimes causes a noise when the chamber temperature is high due to the large load. The noise gets less and less accompanying with the cooling of the chamber.</p>
Back-up test switch does not operate normally (when the backup cooling kit is provided)	<ul style="list-style-type: none"> <li>▪ The liquid carbon dioxide tank is empty.</li> <li>▪ The valve of the carbon dioxide tank is not opened.</li> <li>▪ The ambient temperature is too high. In this case, move the tank to a cool location.</li> </ul> <p>Inquire at liquid carbon dioxide suppliers about its check, adjustment, installation, or move.</p>

**Note:**

If the malfunction is not eliminated after checking the above items, or the malfunction is not shown in the above table, contact our sales representative or agent.

# DISPOSAL OF UNIT

## WARNING

If the unit is to be stored unused in an unsupervised area for an extended period **ensure that children do not have access and doors cannot be closed completely.**

**The disposal of the unit should be accomplished by appropriate personnel. Always remove doors** to prevent accidents such as suffocation.

## Recycle of battery



The unit contains a rechargeable battery. The battery is recyclable. At the end of its useful life, check with your local solid waste officials for options or proper disposal.



\* Label indication is obliged to comply with Taiwanese battery regulation.

## Decontamination of unit

Before disposing a ultra low temperature freezer with biohazardous danger, decontaminate the ultra low temperature freezer to the extent possible by the user.

---

# DISPOSAL OF UNIT

---

## (English)

FOR EU USERS

The symbol mark and recycling systems described below apply to EU countries and do not apply to countries in other areas of the world.

Your Panasonic product is designed and manufactured with high quality materials and components which can be recycled and/or reused.

The symbol mark means that electrical and electronic equipment, batteries and accumulators, at their end-of-life, should be disposed of separately from your household waste.

Note:

If a chemical symbol is printed beneath the symbol mark, this chemical symbol means that the battery or accumulator contains a heavy metal at a certain concentration. This will be indicated as follows: Hg: mercury, Cd: cadmium, Pb: lead

In the European Union there are separate collection systems for used electrical and electronic equipment, batteries and accumulators.

Please, dispose of them correctly at your local community waste collection/recycling centre.

Please, help us to conserve the environment we live in!

## (German)

Für EU-Staaten

Das Symbol und das erwähnte Wiederverwertungssystem gelten nur für die Länder der EU und nicht für andere Länder oder Gebiete in der Welt.

Die Produkte von Panasonic werden aus hochwertigen Materialien und Komponenten gefertigt, die sich wieder verwenden lassen.

Das Symbol bedeutet, dass elektrische oder elektronische Geräte, Batterien und Akkus am Ende ihrer Lebensdauer nicht im Haushaltsmüll entsorgt werden dürfen.

Hinweis:

Ein chemisches Zeichen unter dem Symbol bedeutet, dass die Batterie bzw. der Akku Schwermetalle in gewissen Konzentrationen enthält. Die Metalle werden wie folgt bezeichnet: Hg: Quecksilber, Cd: Kadmium, Pb: Blei

In der Europäischen Union gibt es separate Sammelstellen für elektrische und elektronische Geräte, Batterien und Akkus.

Entsorgen Sie solche Geräte bitte richtig in der kommunalen Sammelstelle bzw. im Recyclingzentrum.

Helfen Sie mit, die Umwelt in der wir leben, zu schützen.



# DISPOSAL OF UNIT

## (French)

### POUR LES UTILISATEURS DE UE

Le symbole et les systèmes de recyclage évoqués ci-dessous s'appliquent uniquement aux pays de UE.

Votre produit Panasonic est conçu et fabriqué avec des composants et des matériaux de hautes qualités qui peuvent être recyclés et/ou réutilisés.

Le symbole signifie que les équipements électriques et électroniques, les batteries et les accumulateurs ne doivent pas être mis au rebut avec les déchets domestiques à l'issue de leur durée de vie.

#### Remarque:

Si un symbole chimique est imprimé sous le symbole, le symbole chimique indique que la batterie ou l'accumulateur contient une certaine concentration de métaux lourds. Les métaux sont indiqués de la manière suivante: Hg: mercure, Cd: cadmium, Pb: plomb.

Il existe différents systèmes de collecte pour les équipements électriques et électroniques, les batteries et les accumulateurs usagés au sein de l'Union européenne.

Veuillez mettre les équipements au rebut de manière correcte, auprès de votre centre de recyclage/de collecte des déchets local.

Aidez-nous à préserver l'environnement dans lequel nous vivons!

Les machines ou appareils électriques et électroniques contiennent fréquemment des matières qui, si elles sont traitées ou éliminées de manière inappropriée, peuvent s'avérer potentiellement dangereuses pour la santé humaine et pour l'environnement.

Cependant, ces matières sont nécessaires au bon fonctionnement de votre appareil ou de votre machine. Pour cette raison, il vous est demandé de ne pas vous débarrasser de votre appareil ou machine usagé avec vos ordures ménagères.

## (Spanish)

### PARA USUARIOS DE LA UNION EUROPEA

El símbolo y los sistemas de reciclado descritos a continuación se aplican para países de la Unión Europea y no se aplica para países en otras áreas del mundo.

Su producto Panasonic fue diseñado y fabricado con materiales de alta calidad y componentes que pueden ser reciclados y/o vueltos a usar.

El símbolo significa que los equipos eléctricos y electrónicos, baterías y acumuladores, al final de su vida útil, debe ser desechados separadamente de sus residuos domiciliarios.

#### Nota:

Si hay un símbolo químico impreso debajo del símbolo, este símbolo químico significa que la batería o acumulador contiene una cierta concentración de un metal pesado. Esto es indicado de la siguiente manera: Hg: mercurio, Cd: cadmio, Pb: plomo

En la Unión Europea hay sistemas de recolección separados para equipos eléctricos y electrónicos, baterías y acumuladores usados.

Por favor, disponga de ellos correctamente en el centro de recolección de residuos/reciclado de la comunidad de su localidad.

Por favor, ayúdenos a proteger el medio ambiente en que vivimos!



# DISPOSAL OF UNIT

## (Portuguese)

PARA UTILIZADORES DA UE

O símbolo e os sistemas de reciclagem descritos abaixo aplicam-se aos países da UE e não se aplicam aos países noutras áreas do mundo.

O seu produto Panasonic foi concebido e fabricado com materiais e componentes de elevada qualidade que podem ser reciclados e/ou reutilizados.

O símbolo significa que o equipamento eléctrico e electrónico, baterias e acumuladores, em final de vida, não devem ser deitados fora juntamente com o lixo doméstico.

Atenção:

Se estiver impresso um símbolo químico debaixo do símbolo de , este símbolo químico significa que a bateria ou acumulador contém um metal pesado numa determinada concentração. Estará indicado da seguinte forma: Hg: mercúrio, Cd: cádmio, Pb: chumbo

Na União Europeia existem sistemas de recolha separados para equipamento eléctrico e electrónico, baterias e acumuladores.

Por favor, entregue-os no seu centro de reciclagem/recolha de lixo local.

Por favor, ajude-nos a conservar o ambiente!

## (Italian)

PER UTENTI UE

Il simbolo e i sistemi di riciclaggio descritti di seguito si applicano esclusivamente ai paesi dell'UE.

Questo prodotto Panasonic è stato progettato e realizzato con materiali e componenti di elevata qualità che possono essere riciclati e/o riutilizzati.

Il simbolo di riciclaggio mostrato di seguito indica che i dispositivi elettrici ed elettronici, le batterie e gli accumulatori, una volta esauriti, devono essere smaltiti separatamente rispetto ai rifiuti domestici.

Nota:

Se sotto il simbolo di riciclaggio appare un simbolo chimico, esso sta ad indicare che la batteria o l'accumulatore contengono metalli pesanti a determinate concentrazioni. Questo viene specificato come segue: Hg: mercurio, Cd: cadmio, Pb: piombo.

Nell'Unione europea esistono diversi sistemi per la raccolta dei rifiuti speciali quali i dispositivi elettrici ed elettronici, le batterie e gli accumulatori.

Si raccomanda di provvedere allo smaltimento di tali rifiuti secondo quanto previsto dalle normative vigenti in materia.

Aiutaci a conservare l'ambiente!



# DISPOSAL OF UNIT

## (Dutch)

### VOOR GEBRUIKERS IN DE EU

Het symbool en de recycleersystemen die hieronder beschreven worden, zijn van toepassing op de landen in de EU en zijn niet van toepassing op landen in andere delen van de wereld.

Uw Panasonic product is ontworpen en gemaakt met materialen en onderdelen van hoge kwaliteit, die gerecycleerd en opnieuw gebruikt kunnen worden.

Het symbool betekent dat elektrische en elektronische apparatuur, batterijen en accu's aan het eind van hun leven apart van uw huisafval weggegooid moeten worden.

Let op:

Indien een chemisch symbool afgedrukt staat onder het symbool, betekent dit chemisch symbool dat de batterij of accu een zwaar metaal met een bepaalde concentratie bevat. Dit wordt als volgt aangegeven: Hg: kwik, Cd: cadmium, Pb: lood

In de Europese Unie zijn afzonderlijke inzamelingssystemen voor gebruikte elektrische en elektronische apparatuur, batterijen en accu's.

Wilt u deze op de juiste manier weggooiden bij uw plaatselijk afvalinzameling-/recyclingcentrum in uw buurt?

Help ons het milieu waarin wij leven in stand te houden!

## (Swedish)

### FÖR ANVÄNDARE INOM EU

Den symbolmärkning och de återvinningssystem som beskrivs här nedan gäller länder inom EU och gäller inte länder i någon annan del av världen.

Din Panasonic-produkt har konstruerats och tillverkats med delar och material av hög kvalitet, som kan återvinnas och/eller återanvändas.

Symbolmärkningen innebär att elektrisk och elektronisk utrustning, batterier och ackumulatorer, vid slutet av deras livslängd, inte får slängas som hushållsavfall utan skall slängas separat.

Observera:

Om en kemisk symbol finns tryckt under denna symbolmärkning, betyder denna kemiska symbol att batteriet eller ackumulatören innehåller en tungmetall med en viss koncentration. Detta indikeras på följande sätt: Hg: kvicksilver, Cd: kadmium, Pb: bly

I den Europeiska Unionen finns det separata uppsamlingssystem för använd elektrisk och elektronisk utrustning, batterier och ackumulatorer.

Gör dig av med sådana saker på rätt sätt på den speciella lokala platsen för återsamling/återanvändning.

Hjälp oss att bevara den miljö vi lever i!



# DISPOSAL OF BATTERY

## Location of a nickel-metal-hydride battery

This unit is provided a nickel-metal-hydride battery for the power failure warning device. The battery is located in the electrical box inside the cover on the lower left side. (Fig. 1)



The high voltage components are enclosed in the electrical box. The cover should be removed by a qualified engineer or a service personnel only to prevent the electric shock..

## Removal of nickel-metal-hydride battery

1. Turn off the power switch and disconnect the power supply plug.
2. As shown in the Fig. 2, remove 7 screws fixing the side cover with a screw driver and remove the side cover..
3. Remove 4 screws fixing the electrical box cover with a screw driver. (Fig. 3)
4. Disconnect the battery connector and remove 2 screws fixing the battery mounting plate. (Fig. 4)
5. Take out the battery.
6. Follow the procedure for recycling or proper disposal.

## Handling of battery

Cover the battery terminal with an insulating tape to avoid the short circuit. Then follow the procedure for recycling or proper disposal.

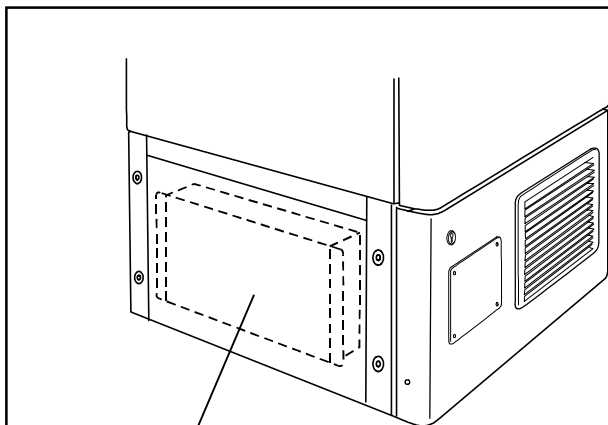

Electrical box

Fig. 1

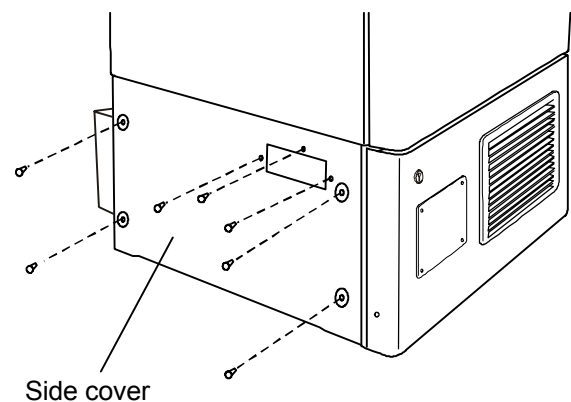

Side cover

Fig. 2

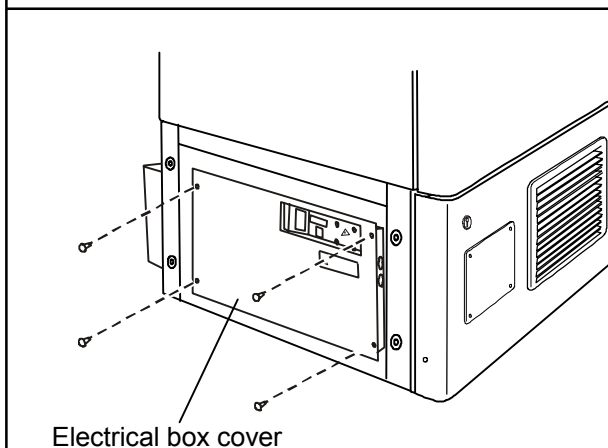

Electrical box cover

Fig. 3

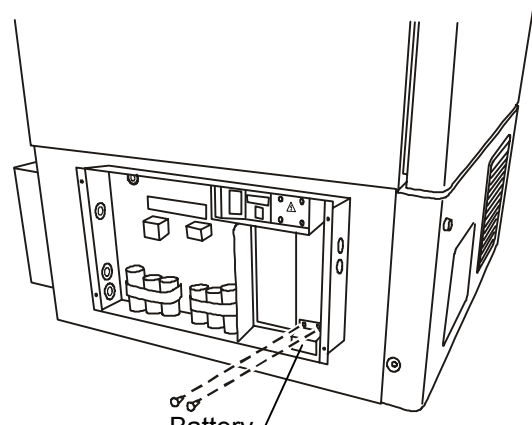

Battery mounting plate

Fig. 4

# TEMPERATURE RECORDER (OPTION)

## **WARNING**

Disconnect the power supply plug before attaching the temperature recorder or it may cause electric shock or fire.

A temperature recorder is available for this freezer as the optional component. The type of the temperature recorder is MTR-G85A or MTR-G85C. Consult our sales representative or agent for the temperature recorder installation.

Following shows the installation procedure.

1. Remove four screws (shown by arrows) on the front panel and take the panel off. Then take off the cover for the recorder mounting space by removing four screws. (Fig. 1)

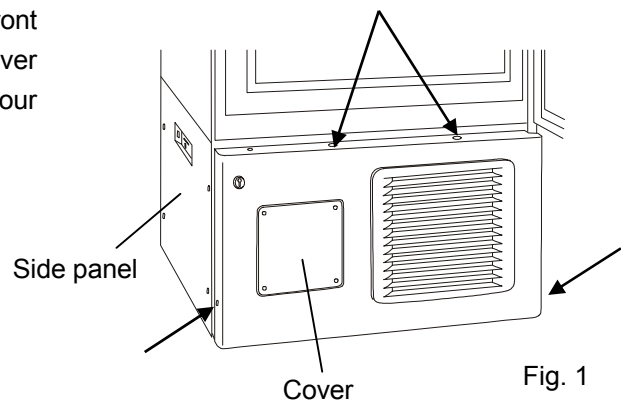

2. As shown in the Fig. 2, insert the temperature recorder to the mounting space and fix it to the back side of the front panel by using the recorder fixture enclosed with the recorder.

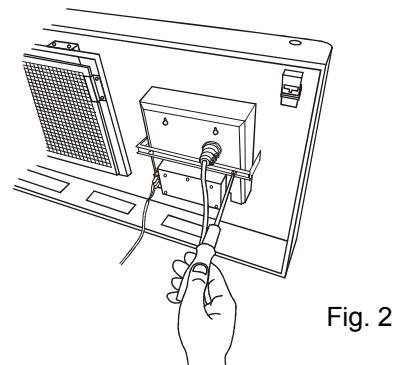

3. Take off the recorder sensor cover in the chamber (bottom left side) by removing two screws. Then remove the rubber cap and insulation covering the access port. (Fig. 3)

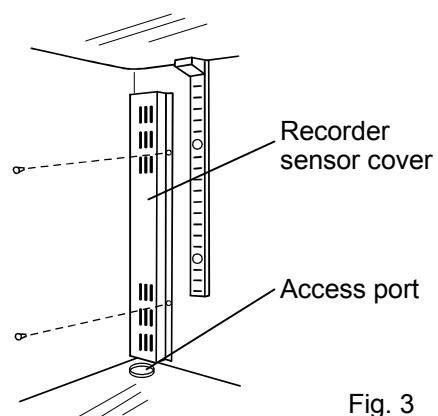



# TEMPERATURE RECORDER (OPTION)

4. As shown in the Fig. 4, pass the recorder sensor through the sensor guide pipe from the front to the back. The sensor guide pipe is provided on the upper left side of the base compartment.

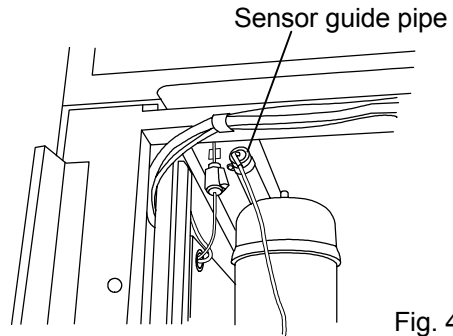

Fig. 4

5. Take out the recorder sensor from the guide pipe at the back side and pass the sensor to the chamber through the access port. (Fig. 5)

The access port is covered with an thermal insulation and rubber cap. Remove them before passing the recorder sensor through it.

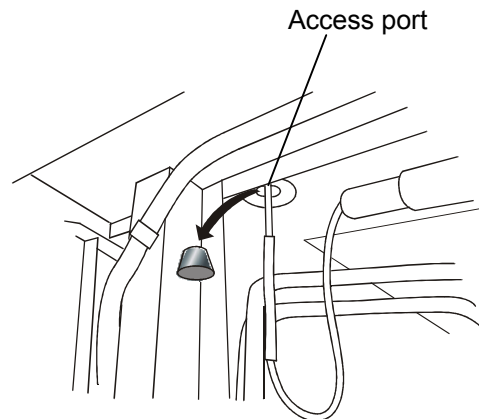

Fig. 5

6. Attach the recorder sensor on the sensor cover with the enclosed clips. (Fig. 6) Seal the access port with a silicon and replace the recorder sensor cover. Fix the cover to the inside wall. (Fig. 3)

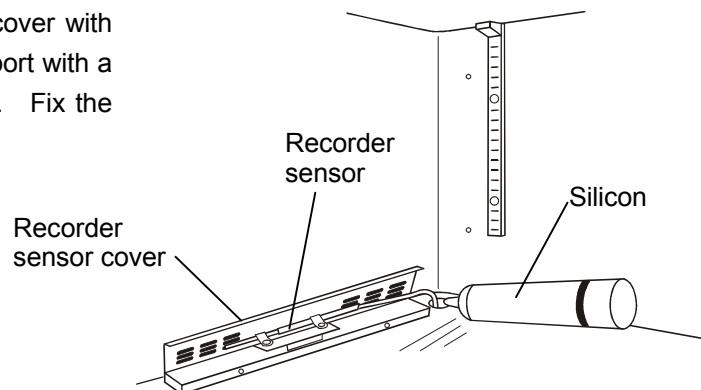

Fig. 6

7. Remove the connector cover. Connect the recorder connector at the end of the power cord with the white connector on the left of the base compartment. Bind the extra lead wire of the sensor with a nylon clip on the back of the recorder. (Fig. 7)

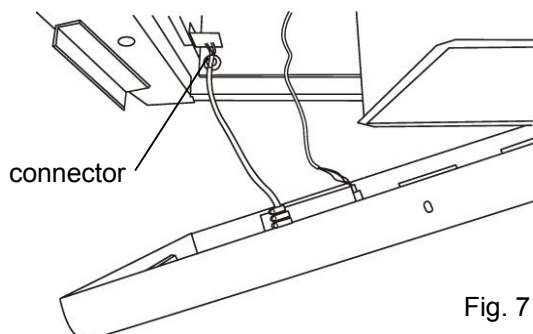

Fig. 7

9. Operate the freezer until the chamber temperature gets to the set temperature. Check the recorded temperature and chamber temperature displayed on the control panel. Adjust the zero adjustment volume on the temperature recorder so that the recorded temperature can corresponds with the displayed temperature if they are not compliance each other.

# BACKUP COOLING KIT (OPTION)

## WARNING

As with any equipment that uses CO<sub>2</sub> gas, there is a likelihood of oxygen depletion in the vicinity of the equipment. It is important that you assess the work site to ensure there is suitable and sufficient ventilation. If restricted ventilation is suspected, then other methods of ensuring a safe environment must be considered. These may include atmosphere monitoring and warning devices.

This freezer can be provided with a backup cooling kit (CVK-UB2 or CVK-UB2(I)) which is available as an optional component. For the installation, refer to the instruction manual enclosed with the system.

### 1. Switch of backup cooling kit (BACKUP)

When turning on the system, the lamp is brightened. This means that the system is ready. To stop the operation of the system, turn off this switch.

### 2. Test switch (TEST)

This switch is for checking the operation of backup cooling kit. Pressing this switch is resulted in the release of liquid carbon dioxide without system operation.

### 3. Temperature setting knob (TEMP. SET)

With this knob, set the temperature at which the system is operated. The effective set temperature range is between -50°C and -70°C.

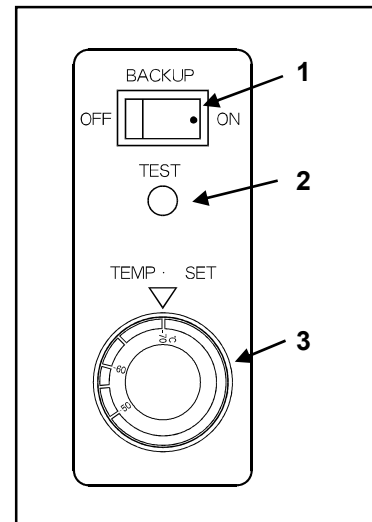

# OPTIONAL COMPONENTS

## Inventory rack

The optional inventory rack is useful to store the precious materials in the chamber effectively. When the rack is used, it is necessary to adjust the height of the shelves. Set the shelf support as shown in the figure below.

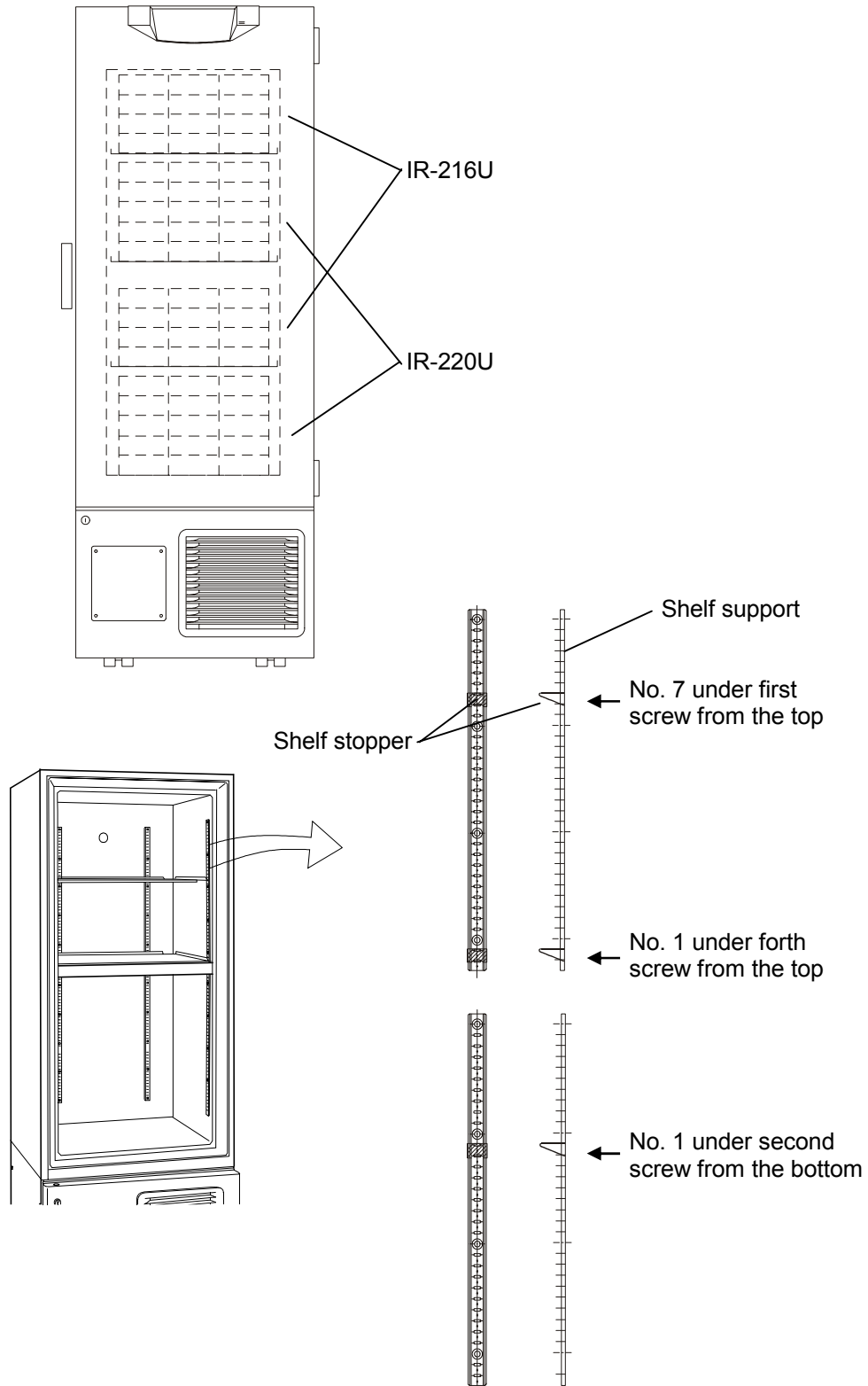

# SPECIFICATIONS

Product name	Ultra-Low Temperature Freezer MDF-U33V
External dimensions	W670 mm x D870 mm x H1860 mm
Internal dimensions	W490 mm x D600 mm x H1140 mm
Effective capacity	333 L
Exterior	Painted steel
Interior	Painted steel
Outer door	Painted steel
Inner door	ABS resin panel with stainless frame, 2 doors
Shelf	Stainless steel, 3 shelves (adjustable) W464 mm x D535 mm, Load; 50 kg/shelf
Access port	17 mm diameter, 3 locations (back, bottom corner (left/right))
Insulation	Vacuum insulation panel + Rigid polyurethane foamed-in place
Compressor	Hermetic type, Output; 450 W (high stage side), 750 W (low stage side)
Evaporator	Tube on sheet type
Condenser	Fin and tube type (high stage side), Shell and tube type (low stage side)
Refrigerant	R-404A (high stage side), R-508 (low stage side)
Temperature controller	Microcomputer control system
Temperature display	Digital display
Thermal sensor	Platinum resistance (Pt 1000 $\Omega$ )
Alarm	High temp. alarm, Low temp. alarm, Power failure alarm, Door alarm
Remote alarm contact	Allowable contact capacity: DC 30 V, 2 A
Battery	Nickel-metal-hydride battery, DC 6 V, 1100 mAh, Auto-recharge (5HR-AAC)
Accessories	1 set of key, 1 scraper
Weight	255 kg
Optional component	Inventory rack (IR-216U, IR-220U) 3 drawers for lower and upper compartment (MDF-30R) Temperature recorder (MTR-G85A, MTR-G85C) Temperature recorder (MTR-85H)+Mounting kit (MDF-S3085) backup cooling kit (CVK-UB2): LCO <sub>2</sub> Interface board (MTR-480)

**Note:**

- Design or specifications will be subject to change without notice.
- Refer to the updated catalog when ordering an optional component.
- The battery for power failure alarm is an article for consumption. It is recommended that the battery will be replaced about every 3 years. Contact our sales agency at the time of replacement of the battery for recycling.
- Fan motors are expendable supplies. Exchange it for about every 6 years. Contact our sales agency at the time of replacement of the fan motor.

# PERFORMANCE

Product name	Ultra-Low Temperature Freezer MDF-U33V			
Model No.	MDF-U33V-PA	MDF-U33V-PB	MDF-U33V-PK	MDF-U33V-PE
Cooling performance	-86°C at the center of the chamber (ambient temperature; 30°C, no load)			
Temperature control range	-50°C to -86°C (ambient temperature; 30°C, no load)			
Power source	AC 115 V	AC 220 V	AC 220 V	AC 230 V/240 V
Power source	60 Hz	50 Hz	60 Hz	50 Hz
Rated power consumption	775 W	640 W	710 W	610 W/650 W
Noise level	49 dB [A] (background noise; 20 dB)			
Maximum pressure	1.9 MPa			

**Note :** The unit with CE mark complies with EC directives

**Note \*:** This freezer is not designed to be provided with an small inner door (MDF-5ID). The status monitor lamp keeps ON because of larger load and we do not guarantee the cooling performance if the independent inner door is installed.

**⚠ CAUTION**

**Please fill in this form before servicing.  
Hand over this form to the service engineer to keep for his and your safety.**

## Safety check sheet

1. Freezer contents :
- |                                |                              |                             |
|--------------------------------|------------------------------|-----------------------------|
| Risk of infection:             | <input type="checkbox"/> Yes | <input type="checkbox"/> No |
| Risk of toxicity:              | <input type="checkbox"/> Yes | <input type="checkbox"/> No |
| Risk from radioactive sources: | <input type="checkbox"/> Yes | <input type="checkbox"/> No |

(List all potentially hazardous materials that have been stored in this unit.)

Notes :

2. Contamination of the unit

- |                  |                              |                             |
|------------------|------------------------------|-----------------------------|
| Unit interior    | <input type="checkbox"/> Yes | <input type="checkbox"/> No |
| No contamination | <input type="checkbox"/> Yes | <input type="checkbox"/> No |
| Decontaminated   | <input type="checkbox"/> Yes | <input type="checkbox"/> No |
| Contaminated     | <input type="checkbox"/> Yes | <input type="checkbox"/> No |
- Others:

3. Instructions for safe repair/maintenance of the unit

- |                                     |                              |                             |
|-------------------------------------|------------------------------|-----------------------------|
| a) The unit is safe to work on      | <input type="checkbox"/> Yes | <input type="checkbox"/> No |
| b) There is some danger (see below) | <input type="checkbox"/> Yes | <input type="checkbox"/> No |

Procedure to be adhered to in order to reduce safety risk indicated in b) below.

Date :

Signature :

Address, Division :

Telephone :

Product name: Ultra-low temperature freezer	Model: MDF-	Serial number:	Date of installation:
---	----------------	----------------	-----------------------

Please decontaminate the unit yourself before calling the service engineer.

**Panasonic Healthcare Co., Ltd.**

1-1-1 Sakata, Oizumi-Machi, Ora-Gun, Gunma 370-0596 Japan

© Panasonic Healthcare Co., Ltd. 2012

Printed in Japan  
7FB6P151487001  
S0412-10512