

Table of Contents

1.	Important Safety Instruction	2
1.1.	An Important Notice	2
1.2.	Storage Instruction.....	4
2.	Product Introduction	5
2.1.	General Characteristics	5
2.2.	Symbols on the LCD Display Panel	7
2.3.	Panel explanation.....	10
2.4.	Communication Port Explanation.....	13
3.	Installation and Operation.....	14
3.1.	Unpacking.....	14
3.2.	Selecting Installation Position.....	15
3.3.	Installation of Accessories Kit.....	15
3.4.	Terminal Block Explanation	16
3.5.	Operation Test and Installation Instruction.....	19
4.	Troubleshooting Guide	31
4.1.	Trouble Shooting	31
5.	Bundled Software Installation Guide.....	33
5.1.	Hardware Installation.....	33
5.2.	Software Installation	33
6.	Customer Options Slots	34
6.1.	R2E(2nd RS-232) card	34
6.2.	RSE(RS-485) card	34
6.3.	USE(USB) card	34
6.4.	DCE(Dry Contact)-B card	35
6.5.	SNMP Cards	36
6.6.	The Installation of those Interface Cards	37
7.	Hot Swappable Battery Replacement	38
8.	Specifications.....	40

Parallel Redundancy On-Line UPS User's Manual

6-10KVA

1. Important Safety Instruction

1.1. An Important Notice

- 1.1.1. For Parallel System installation, please refer to “MSII 6KVA Parallel System Installation Guide”
- 1.1.2. Because of “LITTLE LEAKAGE CURRENTS” generated by the EMI filter of the UPS, it is necessary to double ensure if the earth of the UPS is properly grounded before AC Mains is connected with.
- 1.1.3. To ensure safety in all applications where a UPS is hard wired to the Electrical Supply, ensure that the system is installed by a Qualified Electrical Contractor.
- 1.1.4. The UPS has its own internal energy source (battery). Should the battery be switched on when no AC power is available, there could be voltage at the output terminals.
- 1.1.5. Make sure that the AC Utility outlet is correctly grounded.
- 1.1.6. Do not open the case, as there are no serviceable parts inside. Your Warranty will be void.
- 1.1.7. Do not try to repair the unit yourself; contact your local supplier or your warranty will be void.
- 1.1.8. Please make sure that the input voltage of the UPS matches the supply voltage.
- 1.1.9. Use a certified input power cable with the correct plugs and sockets for the appropriate voltage system.
- 1.1.10. To eliminate any overheating of the UPS, keep all ventilation openings free from obstruction, and do not store "things" on top of the UPS. Keep the UPS 30 cm away from the wall.
- 1.1.11. Make sure the UPS is installed within the proper environment as specified. (0-40°C and 0-90% non-condensing humidity)
- 1.1.12. Do not install the UPS in direct sunlight. Your warranty may be void if the batteries fail.
- 1.1.13. Install the UPS indoors as it is not designed for installation outdoors.

- 1.1.14. Dusty, corrosive and salty environments can do damage to any UPS.
- 1.1.15. Install the UPS away from objects that give off excessive heat and areas that are excessively wet.
- 1.1.16. If liquids are split onto the UPS or foreign objects dropped into the unit, the warranty will be null and void.
- 1.1.17. The battery will discharge naturally if the system is unused for any length of time.
- 1.1.18. It should be recharged every 2-3 months if unused. If this is not done, then the warranty will be null and void. When installed and being used, the batteries will be automatically recharged and kept in top condition.
- 1.1.19. This UPS supports electronic equipment in offices, telecommunications, process control, medical and security applications. Non-authorized technician is not allowed to install the UPS in the following areas.
 - a. Medical equipment directly related to human life
 - b. Elevator, Metro (Subway) system or any other equipment related to human safety.
 - c. Public system or critical computer systems.
- 1.1.20. Do not install the UPS in an environment with sparks, smoke or gas.
- 1.1.21. Make sure the UPS is completely turned off when moving the UPS from one place to another. It might cause electrical shock if the output is not cut completely.
- 1.1.22. The Maintenance Bypass Switch is equipped with the UPS. Please follow the procedures strictly to switch on/off the Maintenance Bypass Switch.
- 1.1.23. The UPS offers CVCF (Constant Voltage Constant Frequency) setting function.
 - a. For correct setting and wiring, please contact with your local agent.
 - b. Do not do it by yourself; otherwise, your warranty will be void.
- 1.1.24. This UPS has been designed and constructed to protect your assets from the wide range of power aberrations experienced on Utility power lines today. It is your insurance for reliable, clean and stable voltage supply. It is worth taking care to install the system correctly and to have it maintained correctly by your local dealer.

1.1.25. **SAVE THESE INSTRUCTIONS** - This Manual Contains Important Instructions that should be Followed during Installation and Maintenance of the UPS and Batteries.

1.1.26. Intended for Installation in a Controlled Environment.

1.1.27. Disconnection Device-CAUTION - A disconnect switch shall be provided by others for ac output circuit. To reduce the risk of fire, connect only to a circuit provided with branch circuit over-current protection for 30 amperes for 6Kva and 40 amperes for 8Kva (10Kva See below details) rating in accordance with the National Electric Code, ANSI/NFPA 70.

10Kva tower Output No.	Output rating	Ratings of output branch circuit Over current protection
No.1 (L21-N21)	5 KVA, 120 V	45
No.2 (L22-N22)	5 KVA, 120 V	45
No.3 (L23-N22)	10 KVA, 208 V	50
No.4 (L21-N22)	10 KVA, 240 V	45

1.1.28. CAUTION - To reduce the risk of fire, unit input connect only to a circuit provided with branch circuit over-current protection for 40 amperes for 6Kva and 50 amperes for 8Kva and 65 amperes for 10Kva amperes rating in accordance with the National Electric Code, ANSI/NFPA 70.

1.1.29. The Units are to be installed so that is not likely to be contacted by people.

1.1.30. Maximum ambient operating temperature 40°C or equivalent

1.2. **Storage Instruction**

For extended storage through moderate climate, the batteries should be charged for 12 hours every 3 months by plugging the UPS power cord into the wall receptacle and turn on input breaker on front panel. Repeat this procedure every 2 months under high temperature environment.

2. **Product Introduction**

2.1. **General Characteristics**

2.1.1. True online architecture continuously supplies in your critical device with a stable, regulated, transient-free pure sine wave AC Power.

2.1.2. 20KHz PWM sine-wave topology yields an excellent overall performance. The high crest factor of the inverter handles all high-inrush current loads without a need to upgrade the power rating.

2.1.3. Multi-functional LCD/LED panel may display various status of the UPS. The LED display may show UPS working status, Utility Status and UPS Abnormal status, in the mean while, the LCD display may show Input/Output Voltage, Frequency, Load Status, Inner cabinet temperature, and Abnormal Phenomenon.

2.1.4. To protect the unit from overloading, it automatically switches to bypass mode in 160 seconds~ 40ms if loading is at 105%~ 150% of rating and in case of overloading at 150% of rating, it switches to bypass mode immediately. It will automatically switch back to inverter mode once overload condition ceases.

2.1.5. Should the output becomes short-circuit, the UPS holds the system and cuts the output automatically till the short circuit situation is removed manually.

2.1.6. Should the unit become overheated, the internal thermal Switch will detect the heat and switch to bypass mode and vice versa.

2.1.7. Fully digitalized control circuit built in the UPS may upgrade the functionality Of the UPS as well as reach a high-level protection of the UPS. Through powerful Communication capability built, it enhances its ability for remote control and monitoring easily.

2.1.8. Maintenance-free sealed-type battery minimizes after-sales service.













2.1.9. Maintenance bypass switch — it provides an easy and safe troubleshooting or maintenance function when the Utility is normal.









2.1.10. Providing four different working modes, such as Normal, ECO, CF50 and CF60, it may widely be used in a variety of applications.

2.1.11. DC-start function makes sure of the start-up of UPS during power outages.

- 2.1.12. Revolutionary battery management circuit analyzes battery discharging status to adjust battery cut-off point and extend the life of batteries.
- 2.1.13. Intelligent temperature-controlled fan may not only extend the life of the fan, but also reduce annoying noise because of sudden fan spin. It remains your office quiet and comfortable as usual.
- 2.1.14. When UPS is out of order, you may read out the possible fault reason from the LCD screen directly, which may reduce down unnecessary repair task a lot.
- 2.1.15. In case the UPS is out of order, Fault status will be shown on the LCD screen.
- 2.1.16. When the UPS is operated under CF50 or CF60 mode, the recommended load connected shall be 75% of rated capacity if the input voltage is 176~280Vac and 50% of the rated capacity if the input voltage is 160~280Vac.

2.2. Symbols on the LCD Display Panel

Item	Symbol	Description
1	LINE	Utility or Bypass Source
2		Battery Low
3		Battery Abnormal
4		UPS Overloading
5		UPS Working in specified mode*
6		A Blackout Transfer occurred in UPS Output
7		Bypass Input Abnormal, UPS fails to transfer to bypass, Bypass Abnormal at ECO mode
8		Utility Input Abnormal
9	OFF	UPS Shutoff
10	LINE OFF	UPS Abnormal Lock
11		UPS Flow Chart
12		4 Digits Measurement Display
13		Indicate the item desired to be measured
14		UPS ON Switch or Alarm Silence
15		UPS OFF Switch
16		Previous Page or Setting Change

17		Next Page
18		Special Function Log in /out
19		Enter or Reconfirmed
20		Utility Input Normal LED
21		Bypass Input Normal LED
22		UPS under Redundancy Mode
23		UPS under ECO Mode
24		UPS Fault or Abnormal Warning LED
25	EPO	Emergency Power Off
26	Er05	Battery Weak or Dead
27	Er06	Output Short Circuit
28	Er10	Inverter Over-current
29	Er11	UPS Overheat
30	Er12	UPS Output Overloading
31	Er14	Fan error
32	Er15	Wrong Procedure to enter Maintenance Mode
33	Er16	Output Parameters Set Error in Parallel System
34	Er17	ID Numbers are in conflict in Parallel System or ID number Error in single unit

35	Er21	Parallel communication error (communication wire disconnected or failure to find ID1 UPS) in parallel system
36	Er24	CVCF mode with Bypass input
37	Er27	The UPS must be operated in normal mode in parallel system
38	Er28	Bypass Overload Time out and cut off output.
39	Er31	The settings of both control board and driver board are not matched each other.
40	Er33	Isolated transformer overheat
41	Er**	Other Error code

**The specified modes include Normal mode, ECO mode, CVCF mode, etc..*

2.3. Panel explanation

2.3.1. Front Panel Function Explanations

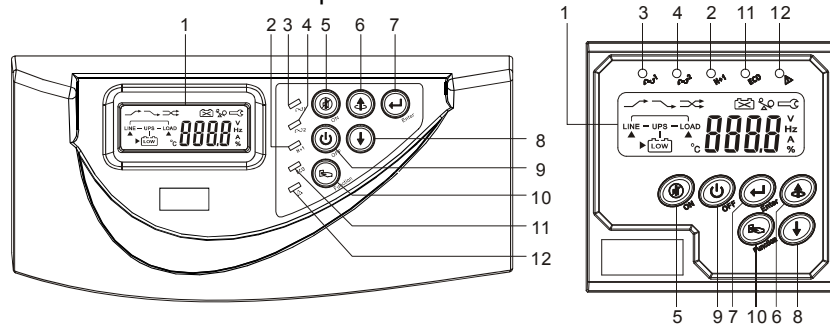

- ① LCD Display
- ② Green LED lights up to indicate the UPS has the capability to run under redundancy mode.
- ③ Green LED steadily lights up to indicate that the Utility input voltage is within the window; the LED flashes flickeringly to indicate that the Utility input voltage is within the acceptable window.
- ④ Green LED lights up to indicate Bypass Input is normal.
- ⑤ UPS ON/Alarm Silence
- ⑥ Go to previous page or change the setting of the UPS.
- ⑦ To re-confirm the change of UPS Setting
- ⑧ Go to next page
- ⑨ UPS OFF Switch
- ⑩ Special functions log in/out
- ⑪ UPS is working under ECO(Economic) mode.
- ⑫ UPS Fault or Abnormal

2.3.2. Rear Panel Explanation

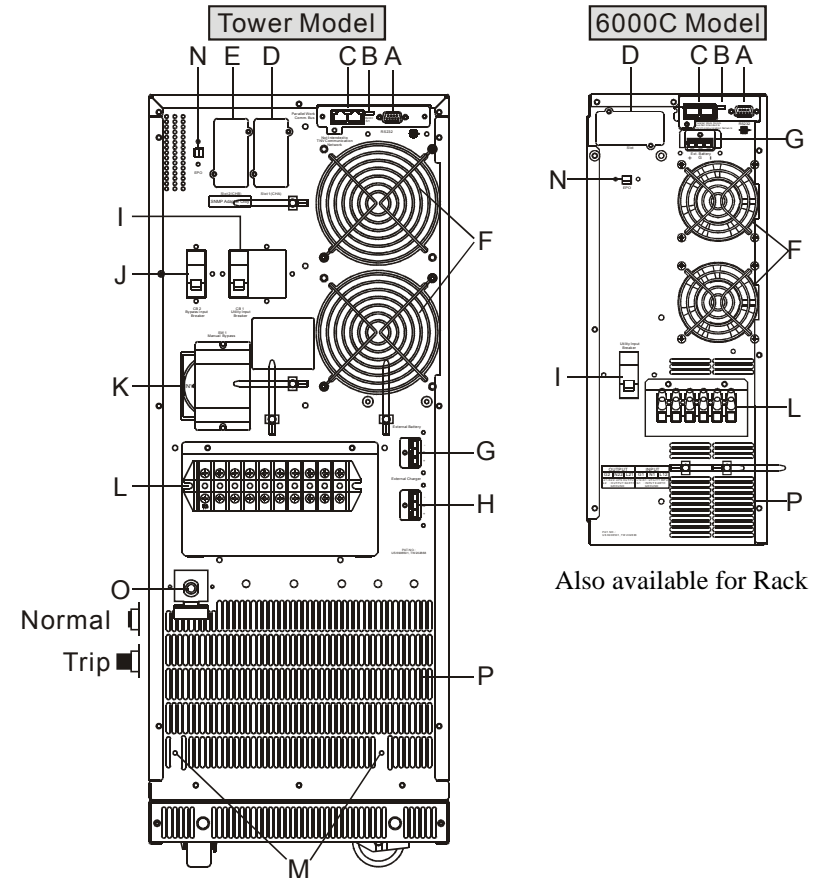

Also available for Rack

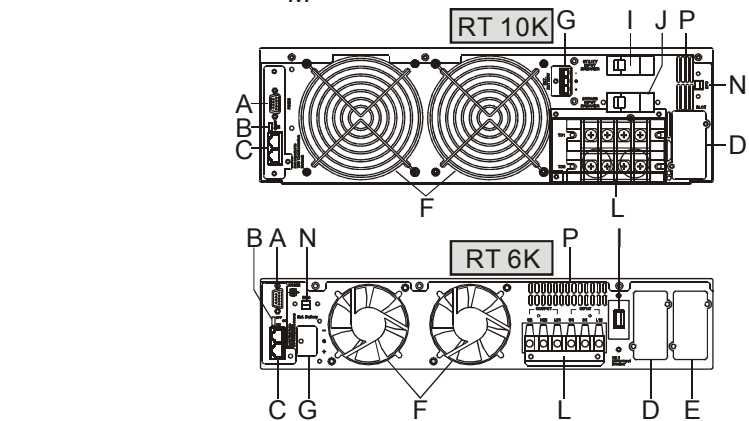

- A RS232 Port
- B Terminal Resistor for Parallel function
- C CAN Bus Connection Port for Parallel System
- D Customer Options Slot 1
- E Customer Options Slot 2
- F Cooling Fan
- G External Battery Connector
- H External Charger Connector
- I Utility Input Breaker CB1
- J Bypass Input Breaker CB2 (for Dual Input Model Only)
- K CAM Switch(Maintenance Bypass Switch)
- L Input/Output Terminal Block
- M Fixing Holes for External Charger Cabinet
- N EPO (Emergency Power Off) : Short to enable the function
- O Thermal breaker for the protection of Load in abnormal condition: CB3**
- P Air Ventilation Hole

● . DIM : Dual Input Model, SIM : Single Input Model

2.4. Communication Port Explanation

The Communication port on the UPS provides true RS232 type to communicate with UPS software to remote monitoring the power and UPS status.

With optional interfaces cards, which contains R2E(2nd RS232), RSE(RS485), USE(USB), DCE(Dry Contact), as well as SNMP/ card, you may combine them according to your demand. However, the R2E card, RSE card and USE card are prohibited to be used Simultaneously.

The bundled software of the UPS is compatible with many operating systems such as Windows 98, & 2000, ME, NT and XP. For other applications like Novell, NetWare, Unix, Linux, please contact your local distributor for a proper solution.

When the optional interface cards are used together with onboard RS232 port in communication, the EPO signals will get the highest priority in control command, then the SNMP/WEB card, then the shutdown command at the DCE card & also R2E, RSE and USE, then onboard RS232 port get the lowest priority.

2.4.1. True RS232 type

2.4.1.1. The RS232 interface settings

The RS232 interface shall be set as follows:

Baud Rate	2400 bps
Data Length	8 bits
Stop Bit	1 bit
Parity	None

2.4.1.2. The Pin Assignments of true RS232 type

The Pin Assignments of true RS232 type are illustrated as follows:

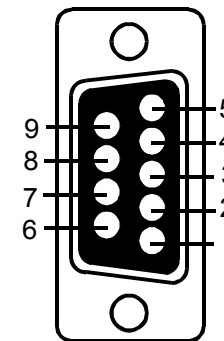

Pin 3: RS232 Rx
 Pin 2: RS232 Tx
 Pin 5: Ground

3. Installation and Operation

The packing condition and the external outlook of the unit should be inspected carefully before installation. Retain the packing material for future use.

3.1. Unpacking

- 3.1.1. Take the UPS out of the PE foam.
 - 3.1.2. Unwrap the UPS.
 - 3.1.3. Standard Package includes:
 - 1 set of Quick Start Manual
 - 1 set of User's Manual
 - 1 set of UPS communication software with RS232 cable
 - 1 set of Metal Accessories Kit for Tower model or RT model as below:
 - 3.1.4. Package for the UPS with Isolation transformer & dual input:
 - Ditto, but with additional 3pcs wire No 7.
 - 3.1.5. Package for the UPS without isolation transformer but dual input:
 - Ditto, but with additional 1pcs wire No. 7.
- (p.s. Wire No. 7 is to be used at the input/output terminal block of the UPS. Please refer to Chapter 3.4 for installation.)

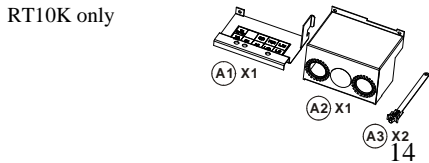
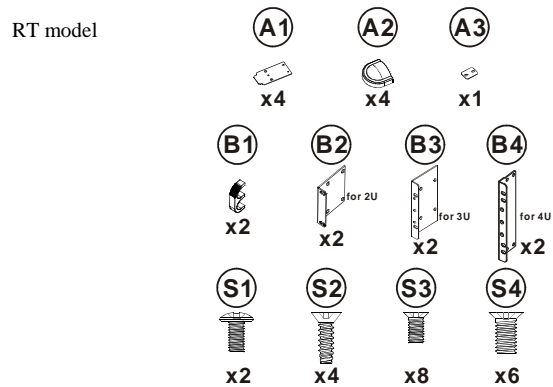
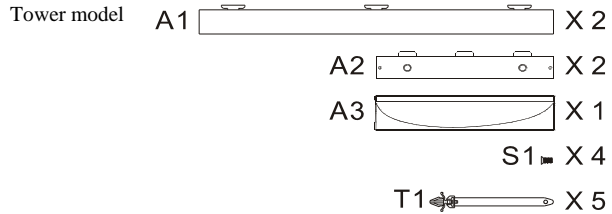

3.2. Selecting Installation Position

It is necessary to select a proper environment to install the unit, in order to minimize the possibility of damage to the UPS and extend the life of the UPS. Please follow the advice below:

1. Keep at least 30cm (12 inches) clearance from the rear panel of the UPS to the wall.
2. Do not block the air-flow to the ventilation openings of the unit.
3. Please check the installation site to avoid overheat and excessive moisture.
4. Do not place the UPS in an environment near dust, corruptive or salty material or flammable objects.
5. Do not expose the UPS to outdoors.

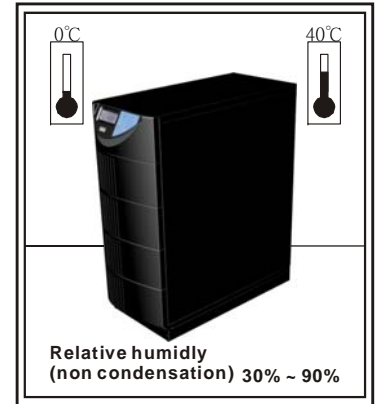
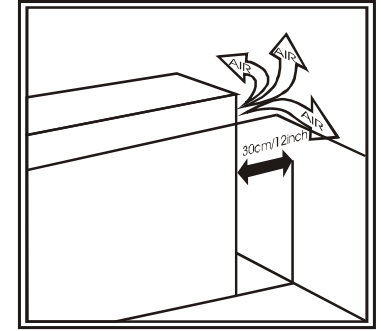

3.3. Installation of Accessories Kit

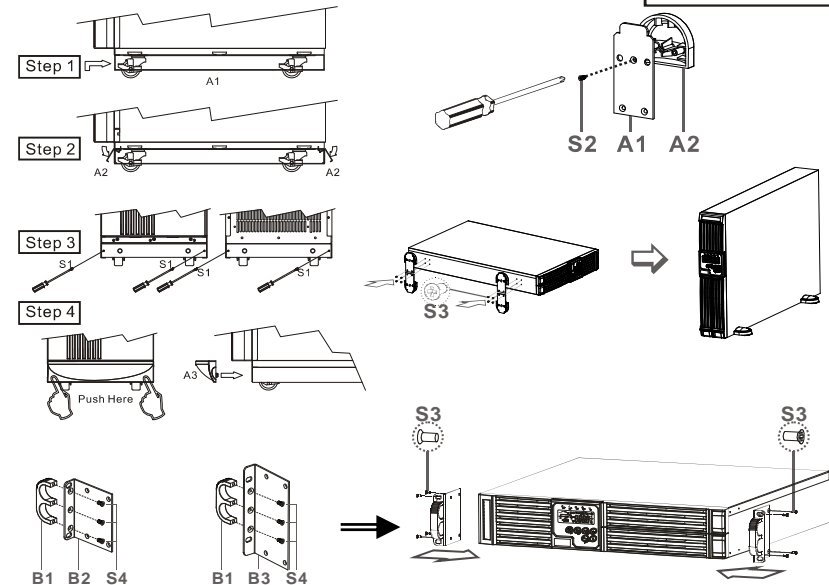

3.4. Terminal Block Explanation

Tower model

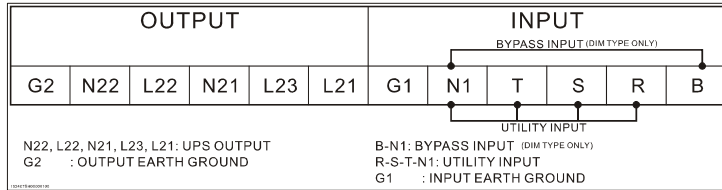
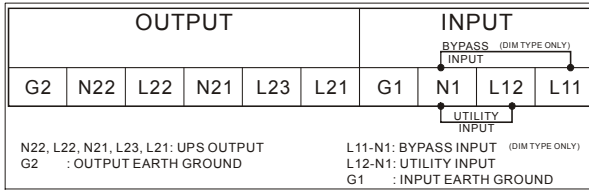

6000C or RT6K model

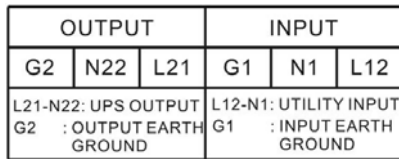

RT10K model

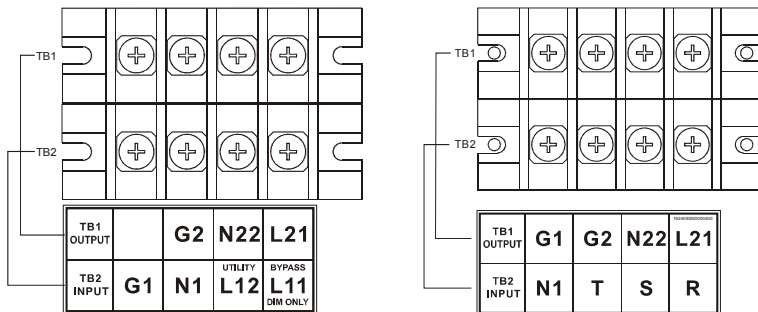

- **L11-N1**、**B-N1**: the terminal for Bypass Input to provide the power source when the UPS is working under bypass mode.
- **L12-N1**、**R-S-T-N1**: the terminal for Utility Input to provide the power source when the UPS is working under Utility mode.
- **G1**: the terminal for UPS Input Ground.
- **L21**、**L23**、**N21**、**L22**、**N22**: the terminals for UPS Output.
- **G2**: the terminal for UPS Output Ground.

Remarks:

1. The maximum current for each terminal is 30Arms for 6Kva, 50Arms for 10Kva.
2. If the UPS is DIM(Dual Input) type whose Utility and Bypass Sources are the same, L11 and L12 would have to be shorted for 1-phase input model, and short B and R for 3-phase input model.
3. If the UPS is SIM(Single Input) type, only AC source can be supplied to UPS from L12-N1 terminal for 1-phase input model and R-S-T-N1 terminal for 3-phase input model.
4. When the Isolation transformer is NOT installed into the tower type UPS, the UPS output terminals will be L22-N22..
5. When the Isolation transformer is installed into the tower type UPS:
 - a. For 100/110/115/120Vac system, you may connect as shown in below.

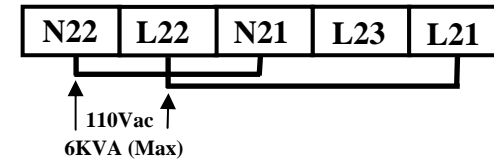

- b. For 200/100Vac, 220/110Vac, 230V/115Vac, or 240/120Vac, or 240/208/120Vac system, You may connect as shown in below.

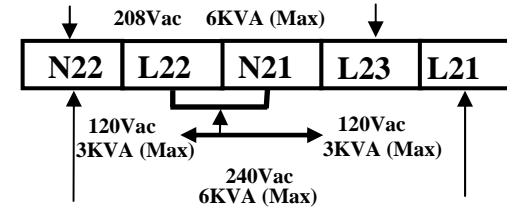

- Use Mounting Cable Tie to fix cables.

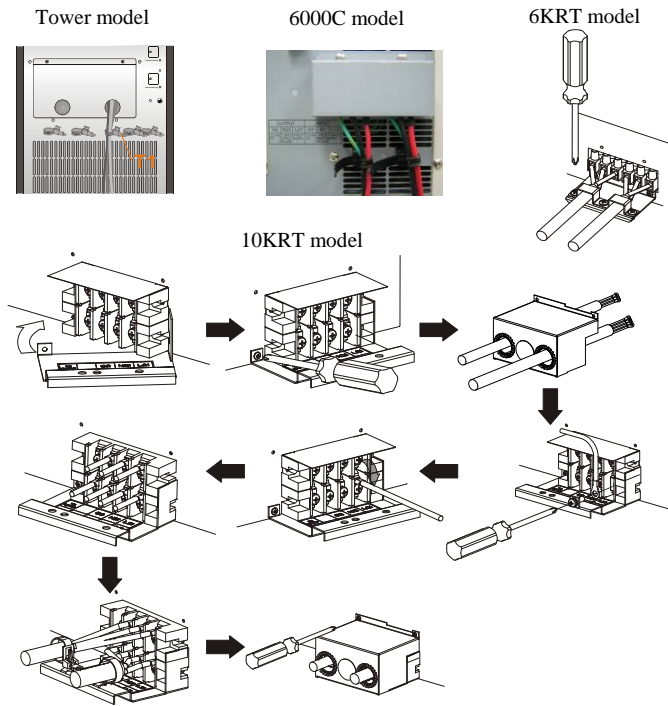

6. Please refer to the specs of input current, output current and recommended conductors listed as below :

a. AC input and output (75°C minimum copper wire)

Model	Maximum Current	Conductor Section	Torque force
4.5KVA	25A	AWG # 10	
6KVA	33A	AWG # 9	
8KVA	43.4A	AWG # 8	23 lb-in
10KVA	54.3A	AWG # 6	23 lb-in

b. Battery input

Model	Maximum Current	Conductor Section
4.5KVA	19A	AWG # 10
6KVA	25A	AWG # 10
8KVA	33A	AWG # 10
10KVA	41A	AWG # 10

3.5. Operation Test and Installation Instruction

3.5.1. Start Up in Normal Mode

3.5.1.1. Open the terminal block cover on the rear panel (refer to 2.3.2)
Before start the installation, please make sure the grounding is connected properly.

3.5.1.2. Make sure Utility breaker, UPS' Utility breaker and Bypass breaker are On "Off" position.

3.5.1.3. Make sure the voltage of Utility matches with the input voltage window of the UPS.

3.5.1.4. Connect the Utility separately to the terminal blocks of UPS' Utility and Bypass Inputs. Switch on the Power Breaker of the distribution panel and the breakers of the UPS' Utility and Bypass Inputs, and then the UPS starts up. Green LEDs ~ 1 & ~ 2 light up to show the Utility and Bypass Inputs are normal and the LCD display with parallel function will illustrate from drawing A1, drawing A2 to drawing B. Otherwise the LCD display will illustrate from drawing A2 to drawing B.

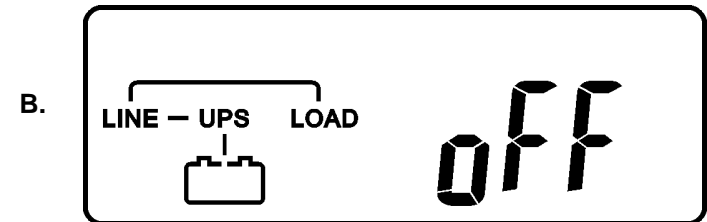
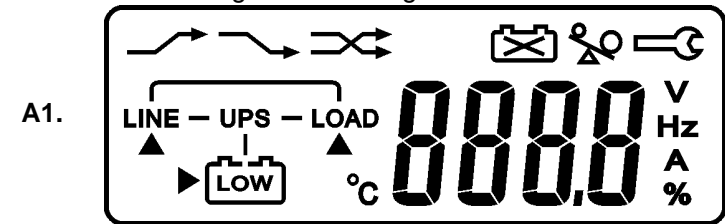

3.5.1.5. Then, the UPS is on Bypass Mode now and it will proceed self-test automatically. If there is no abnormal message occurred, it means the pre-startup of the UPS is successful and the charger starts to charge the batteries.

3.5.1.6. Press the UPS On Switch  for approx. 3 seconds, then the Buzzer sounds twice and the LCD display changes from drawing B to drawing C.

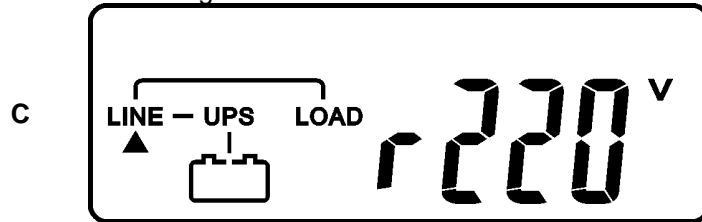

3.5.1.7. Then, the UPS is under self-test mode again, the LCD display will illustrate from drawing C to drawing D and remain approx. 4 seconds under battery mode, then illustrate from drawing E1 to drawing F if the self-test is successful.

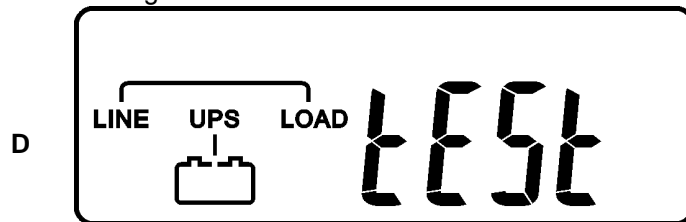

* It shows "test".

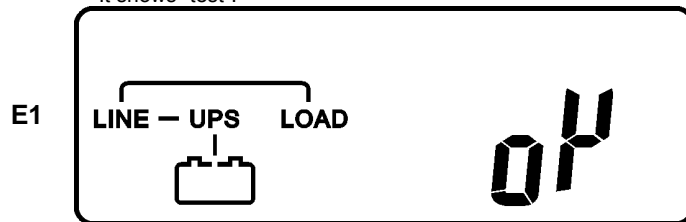

* It shows "OK" in self-test

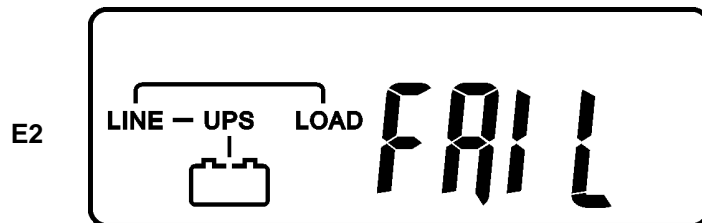

* It shows "Fail" in self-test

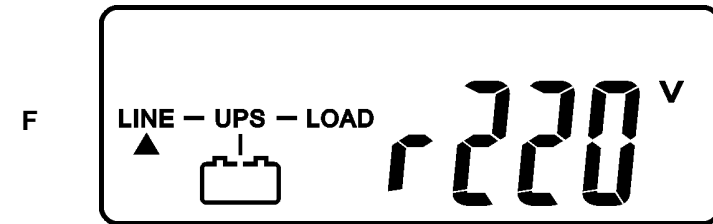

* It shows "220Vac" in Utility Input.

3.5.1.8. In case of failure in self-test, the LCD display will illustrate from Drawing D to drawing E2, then an error code or error status will be shown on the screen.

3.5.1.9. Your start-up operation of the UPS is completely now. Make sure the UPS is plugged onto the wall receptacle for charging at least 8 hours and the batteries of the UPS are fully charged.

3.5.2. Start-up in Battery Mode (Cold Start)

3.5.2.1. Make sure the UPS you have has already been installed at least 1 set(20pcs) of 12V/7AH batteries.

3.5.2.2. Push the UPS On Switch  once for approx. 5 seconds to awake the UPS, and then the buzzer sounds twice. The LCD display will illustrate from drawing A to drawing G, and keep awake for approx. 15 seconds.

3.5.2.3. Press the UPS On Switch  of the UPS again for about 3 seconds till the LCD display illustrates from drawing G to drawing H, then the UPS will be in self-test Mode. The UPS may offer energy to the output in a minute, and the LCD display illustrates as drawing I. In case of failure in pushing the UPS On Switch within 15 seconds, the UPS will automatically turn off. You then have to go through step 3.5.2.1 to 3.5.2.3 once again.

3.5.2.4.

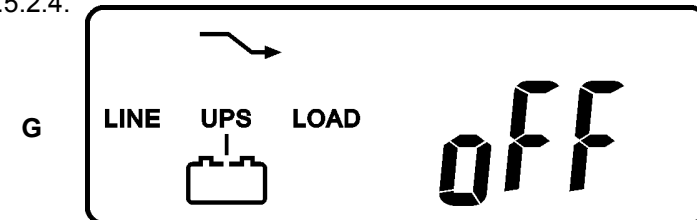

● It shows "Off", which means the UPS pre-start is successful.

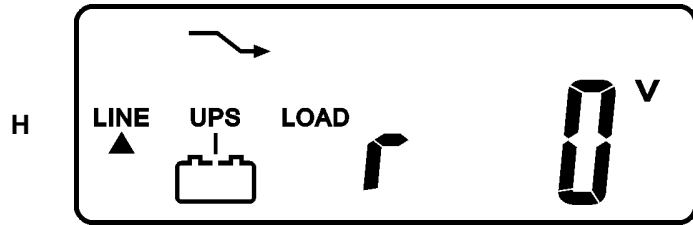

* It shows Utility input is "0" and Utility Abnormal.

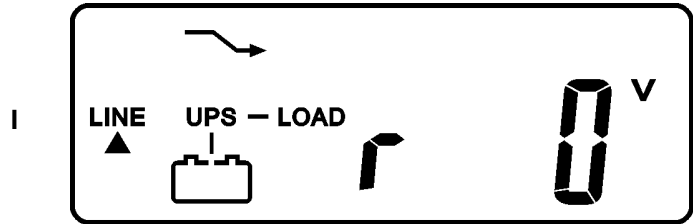

3.5.3. Check Measured Values & Figures detected by UPS

3.5.3.1. If you would like to check the measured values & figures detected

by the UPS, please use scroll up (↑) and scroll down (↓) key pads. When you use scroll down key pad, the LCD display will illustrate as Drawing C(Voltage from Utility Input) → Drawing I1(Voltage from Bypass Input) → Drawing J(Frequency from Utility Input) → Drawing K(Frequency from Bypass Input) → Drawing L(UPS Output Voltage) → Drawing M(UPS Output Frequency) → Drawing N(UPS Output Load %) → Drawing O(UPS Battery Voltage) → Drawing P(UPS Inner Temperature).

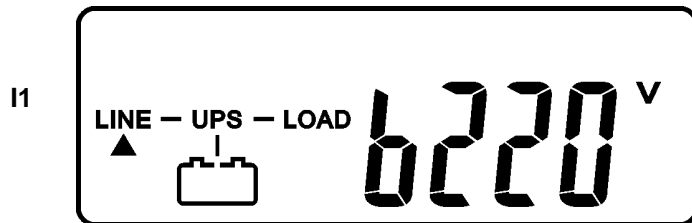

* It shows voltage comes from Bypass Input

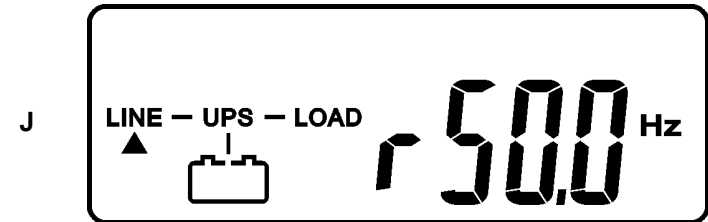

* It shows frequency from Utility Input.

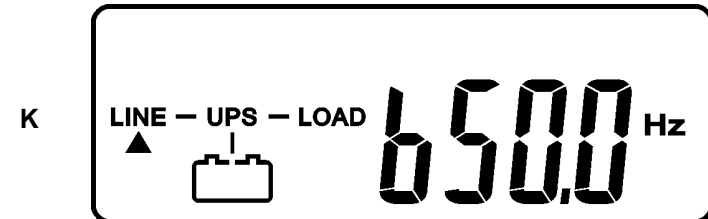

* It shows frequency from Bypass Input.

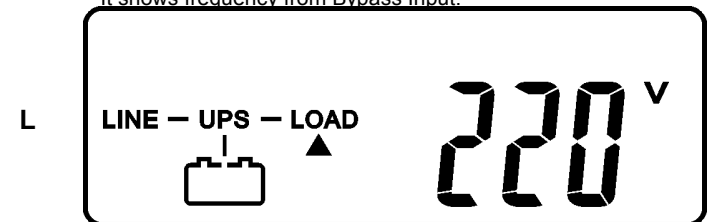

* It shows UPS output Voltage.

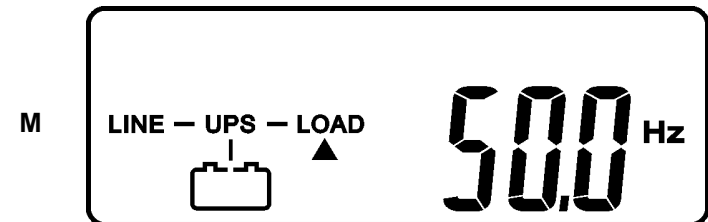

* It shows UPS output frequency.

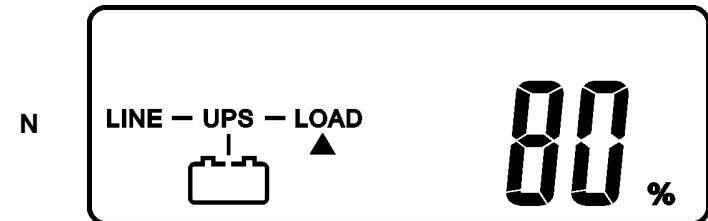

* It shows UPS output load level(%)

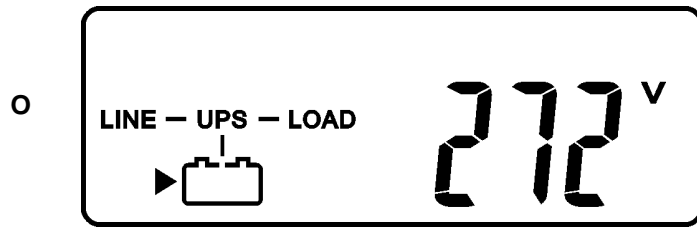

* It shows Battery Voltage.

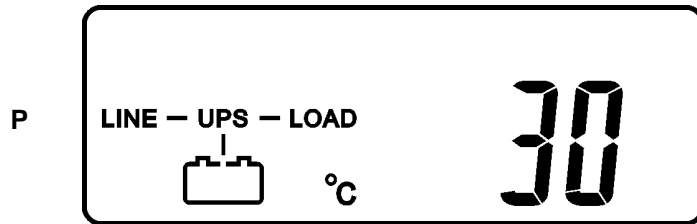

* It shows UPS Inner Temperature

3.5.4. UPS Default Data and Special Function Execution

3.5.4.1. After UPS completely starts up, press key pad to change the LCD display screen to drawing Q1.

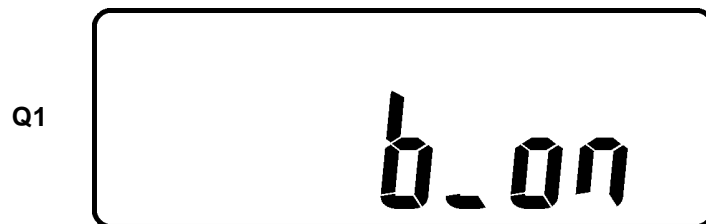

* It shows buzzer "On".

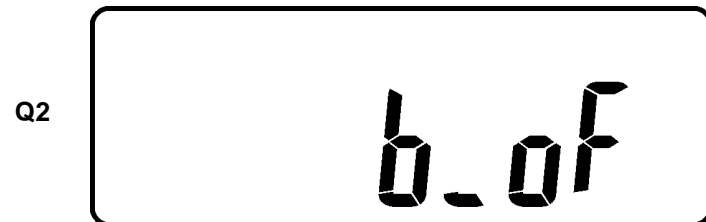

* It shows buzzer "Off".

3.5.4.2. Press key pad to scroll down the screen and check the UPS settings. The LCD display will show in consequence between Drawing Q1(buzzer) → Drawing R1(Self-test) → Drawing S1(Bypass Voltage Windows) → Drawing T(Output Frequency Synchronization Window) → Drawing U(Inverter Output Voltage) → Drawing V1(UPS Operation Mode) → Drawing W(Output Voltage Micro Tune Value) → Drawing X(UPS Id) → Drawing Y(Parallel function status).

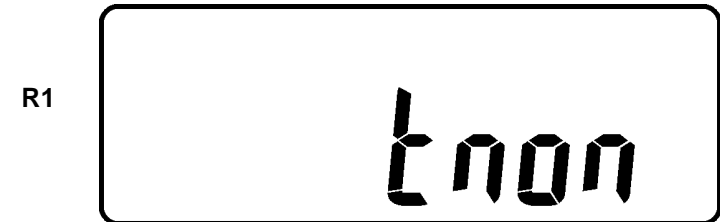

* It shows self-test is NOT "on".

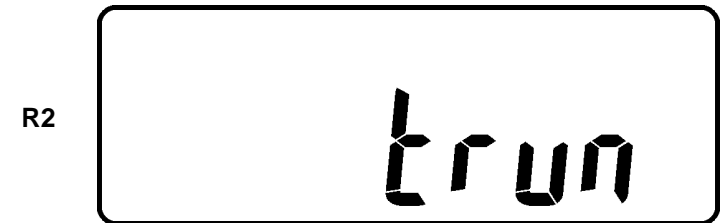

* It shows self-test is "On".

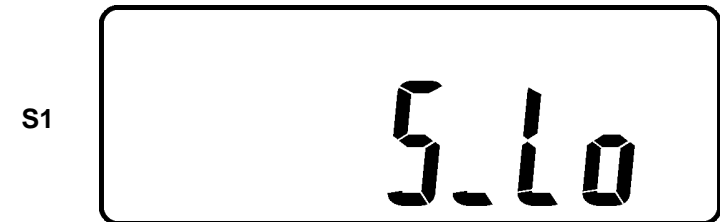

* It shows Bypass Voltage is adjusted to narrow one.

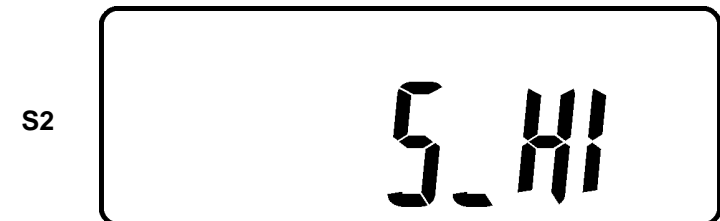

* It shows bypass voltage is adjusted to wider one.

T



* It shows Frequency Window is +/-3Hz.

U



* It shows inverter output voltage.

V1

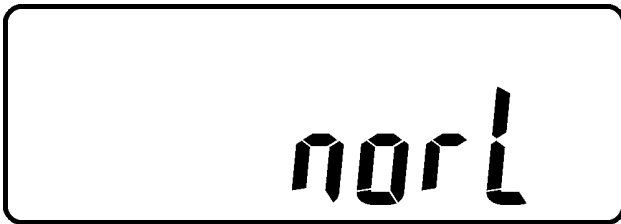

* It shows the UPS is operated in "normal mode".

V2

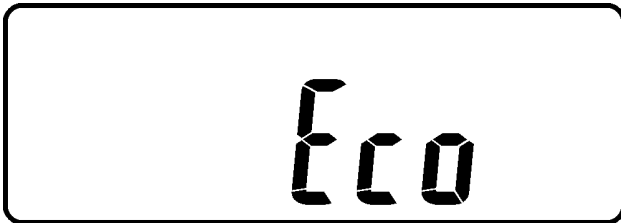

* It shows the UPS is operated in "Eco mode".

V3

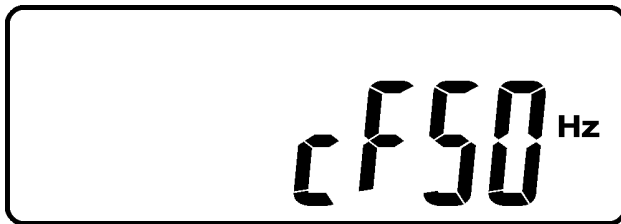

* It shows the UPS is operated in "CVCF 50Hz mode".

V4

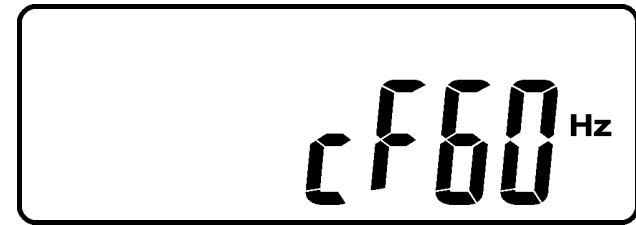

* It shows the UPS is operated in "CVCF 60Hz mode".

W

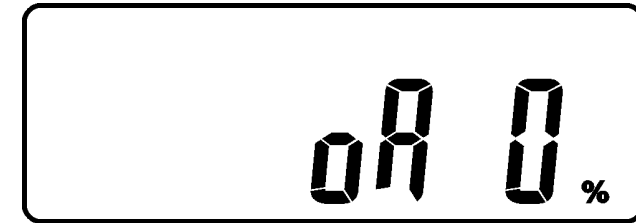

* It shows Output Voltage Adjustment % from 0% to 3% or -0% to -3%.

X



* It shows UPS Identification Number.



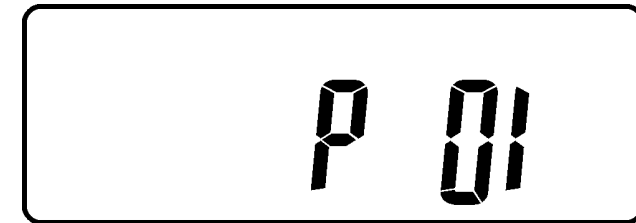

Y



* It shows the UPS is in the No. 1st of parallel systems.

3.5.4.3. Press scroll up  key pad, you may execute special functions. The Functions includes buzzer ON (as drawing Q1), or buzzer OFF (as drawing Q2, Alarm silence for UPS Warning) and self-test OFF (As drawing R1) or self-test ON. (as drawing R2. UPS will execute battery test for 10 seconds. If the self-test is successful, it will show as Drawing E1; otherwise, it will show as drawing E2 & error message in the same time.)

3.5.4.4.
3.5.5. UPS Default Settings and their alternatives

- 3.5.5.1. Make sure the UPS is not “On” yet. Press On Switch  and scroll down  key pads simultaneously for approx. 3 seconds, the buzzer will sound twice, the LCD display screen shows as drawing Q1, then the UPS is under setting mode now.
- 3.5.5.2. To scroll down the LCD screen, you may refer to Chapter 3.5.4.2
- 3.5.5.3. Except Buzzer(as drawing Q1 & Q2) and Self-test(as drawings R1 & R2), all the rest default settings may be changed by pressing scroll up  key pad.
- 3.5.5.4. Drawings S1 and S2 mean the bypass input acceptable window, it can be 184Vac~260Vac or 195Vac~260Vac.
- 3.5.5.5. Drawing T means the bypass frequency window of the Inverter Output, the acceptable setting values are $\pm 3\text{Hz}$ and $\pm 1\text{Hz}$.
- 3.5.5.6. Drawing U means the acceptable Inverter Output Voltage, of which voltage is 200Vac, 208Vac, 220Vac, 230Vac, or 240Vac.
- 3.5.5.7. Drawing V1, V2, V3 and V4 mean the operation modes of the UPS, of which alternative is Online, Eco(Economic) mode, fixed 50Hz Output or fixed 60Hz Output.
- 3.5.5.8. Drawing W means the adjustments of the Inverter Output, which may be calibrated as 0%, +1%, -1%, +2%, -2%, +3%, or -3%.
- 3.5.5.9. Drawing X means a specified address & position of the UPS when the UPS is in Parallel mode. The settable numbers are from 1st to 4th. The number must be 1st if the UPS is not in parallel.
- 3.5.5.10. Drawing Y means the parallel function status. The “P 01” means parallel function disabled and the “P 02” means parallel function enabled.
- 3.5.5.11. When all the setting changes are done, you have to press enter  key Pad to save all the changes when the LCD screen shows as drawing Z, then, the LCD screen will show as drawing AA to complete the setting changes. If you don't want to change those settings, you may press “OFF”  key pads for 5 seconds, then the LCD screen turns to Drawing AA directly, which means your setting changes are invalid.

Z







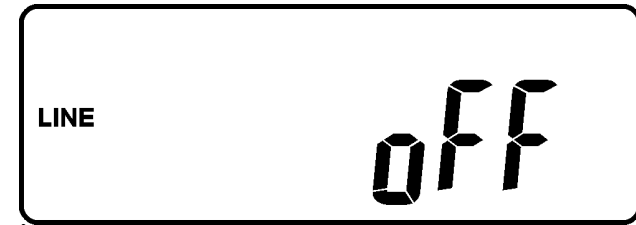

* Please press Enter key to save data.



AA



* It shows the UPS is locked.

- 3.5.5.12. Turn Off the breaker of Utility Input.
- 3.5.5.13. Your Setting changes are complete.
- 3.5.6. UPS Is Off Due to Unknown Reason and Its Trouble Shooting
- 3.5.6.1. If there is a serious abnormal condition occurred, the UPS will lock it itself in “OFF” position as shown in drawing AA and a abnormal message will show on the LCD screen.
- 3.5.6.2. After 3 seconds, all messages will be locked except Bypass messages(LED  & LCD ). In case the Utility is abnormal after the UPS is locked, the LED  will be extinguished and the LCD  will be shown on the LCD screen.
- 3.5.6.3. To release the UPS lock, please proceed the followings:
- 3.5.6.3.1. Check those error messages recorded.
- 3.5.6.3.2. Check to see Chapter 2.2 to trouble shoot the problem of the UPS. Otherwise, consult your local distributor for service.
- 3.5.6.3.3. Press Off  key pad for 5 seconds and buzzer will sound twice.
- 3.5.6.3.4. Turn Off the Breaker of Utility Input.
- 3.5.6.3.5. The UPS lock problem is solved now, but you shall contact with your Local distributor to make sure the error message shown is solved.
- 3.5.7. Shut Off
- 3.5.7.1. Press Off  key pad for about 5 seconds, the Inverter output will be turned off, then the output load is supplied by Bypass loop and the LCD screen shows as drawing B.
- 3.5.7.2. Turn Off the breakers of Utility and Bypass Input.
- 3.5.7.3. The UPS is turned off completely.
- 3.5.8. Maintenance Bypass Mode

3.5.8.1. It is for UPS maintenance only. A Non-authorized technician is not allowed to operate the following procedures. If there is any damage under unauthorized condition, your warranty will be void immediately.

- 3.5.8.1.1. Press the Off  key pad for approx. 5 seconds, the LCD screen shows as drawing B and the UPS output is on bypass mode.
- 3.5.8.1.2. Release the cover of the CAM Switch(Maintenance Bypass Switch) first, then turn on the CAM Switch to “Bypass” mode, and at the right-hand upper Corner of the LCD screen will show  sign.
- 3.5.8.1.3. Turn off the UPS Utility breaker as well as Bypass Input Breaker, you then may proceed UPS maintenance now.
- 3.5.8.1.4. To repeat 3.5.1.4, you may put the UPS back to normal working mode, then turn back the CAM switch to “INV” mode, fasten back the cover and repeat 3.5.1.5 to 3.5.1.8 The UPS will switch back to inverter mode.
- 3.5.8.1.5. It is required to go through 3.5.8.1.1 first, then go through 3.5.8.1.2 If you skip 3.5.8.1.1, the UPS will alert for 10 seconds to warn that the procedure is abnormal, which may damage the UPS due to uncertain utility status. The UPS will switch back to Inverter mode immediately if you turn the CAM switch back to “INV”.



4. Troubleshooting Guide

4.1. *Trouble Shooting*

When the UPS malfunctions during operation, you may check the followings:

- a. Are the wirings of input and output correct?
- b. If the input voltage of the Utility is within the input window of the UPS?

In case problems or symptoms still exist, please proceed the followings for proper adjustment. Should the problem persists, please contact your local distributor for help.

Situation	Check Items	Solution
UPS Red Fault LED lights up	Check the error code shown on the LCD screen 1. Er05,  &  2. Er06, Er10, Er12 Er28 &  3. EPO 4. Er11, Er33 5. Er14 6. Er15 7. Er16, Er27 8. Er21 9. Er24 10. other error code	1. Check to see if the battery connection is properly done, then re-charge the batteries for 8 hours to see whether the UPS may backup normally; otherwise, consult your local distributor right away. 2. If the CB3 is tripped, please turn off the UPS completely and keep the CAM switch at position INV before pressing CB3. Then remove some uncritical load at the UPS output end. If any damage of the coating of AC power cord, please replace a new one. 3. Remove the short circuit occurred at the EPO terminal. 4. Remove the objects blocked onto the ventilation holes. 5. Check the cooling fans on rear panel are working normally. 6. Make sure the UPS is operated normally. If it is on CVCF mode, you have to turn off and turn on the UPS again. 7. All of parameters except ID Number in the parallel UPS must be same. Please refer chapter 3.5.5 to set them again 8. Reconnect the RJ-45 wire or set a UPS with ID=1. 9. When the UPS is on CVCF mode, it is prohibited to have bypass input. You have to turn off the UPS and bypass input and re-start the UPS. 10. Consult your local distributor for help.
UPS fails to offer battery backup or its back up time is shorter than its calculation.		If the backup time is still too short after 8 hours of charge, please contact your local distributor for battery replacement.
UPS locks itself and it can not be turned off.		Please refer to chapter 3.5.6 to trouble shoot the problem; otherwise, consult your local distributor for help.

5. Bundled Software Installation Guide

5.1. Hardware Installation

1. Connect the male connector of RS232 cable to the UPS communication port.
2. Connect the female connector of the RS232 cable to a dedicated RS232 port of the computer.
3. For optional interface cards, you may refer to Chapter 6 for installation.

5.2. Software Installation

Please refer to the user's manual of the software for installation.

6. Customer Options Slots

6.1. R2E(2nd RS-232) card

- 6.1.1. CN1 is for RS232 DB9.
- 6.1.2. For communication protocol, please refer to Chapter 2.4.1
- 6.1.3. Installation Position: slot1(CHA-CN4) or slot 2(CHB-CN5).

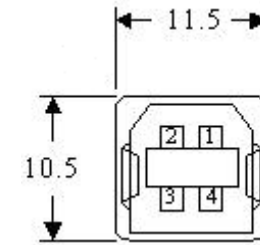

- 1 → VCC (+5V)
- 2 → D-
- 3 → D+
- 4 → Ground

6.2. RSE(RS-485) card

- 6.2.1. CN1 is for the function of the terminal resistor. Short pin1-2 to enable the function and short pin2-3 to disable it.
- 6.2.2. CN2 for RS485 and CN3 for remote power.
- 6.2.3. Definition

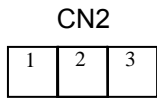

- 1 → Ground
- 2 → A/Data+
- 3 → B/Data-

CN3

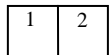

- 1 → AC+
- 2 → AC-

- 6.2.4. Installation Position: slot1.

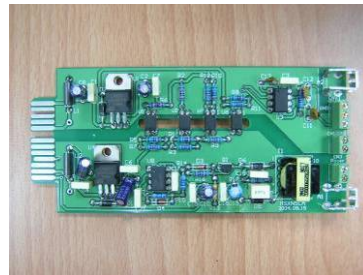

6.3. USE(USB) card

- 6.3.1. CN1 for USB.
- 6.3.2. Definition
 - 6.3.2.1. Comply with USB version 1.0,1.5Mbps
 - 6.3.2.2. Comply with USB HID Version 1.0.
 - 6.3.2.3. The Pin Assignments of the USE card:



- 6.3.3. Installation Position: slot1 (CHA-CN3) or slot 2 (CHB-CN4) .

6.4. DCE(Dry Contact)-B card

- 6.4.1. The pin assignments of 10-Pin Terminal:

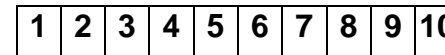

- Pin 1: UPS on Bypass mode.
- Pin 2: Utility Abnormal
- Pin 3: Utility Normal
- Pin 4: Inverter On
- Pin 5: Battery Low
- Pin 6: Battery Bad or Abnormal
- Pin 7: UPS Alarm
- Pin 8: Common
- Pin 9: Shutdown UPS positive(+) signal
- Pin 10: Shutdown UPS positive(-) signal



- 6.4.2. The shutdown function will be activated, after a +6~+25Vdc is put between pin9 and pin10 for 5 seconds.
- 6.4.3. The capacity of each relay contact is 40Vdc/25mA.
- 6.4.4. Installation Position: slot1(CHA-CN7) or slot 2(CHB-CN8).
- 6.4.5. Flexible signal output for N.C.(Normal close) or N.O.(Normal open) contact by shorting pin1-2 or pin2-3 from JP1-5.
- 6.4.6. The shutdown function will be enabled in 1 minute after blackout occurs if the pin1-2 of both CN1 and CN6 be shorted by cap. Or, the shutdown function can only be enabled by pin9-10 of CN3 if the pin2-3 of both CN1and CN6 be shorted by cap. (Refer to 6.4.2)

6.5. SNMP Cards

6.5.1. SNMP/WEB card

6.5.1.1. For installation, please refer to the user's manual attached with the card.

6.5.1.2. Installation

6.5.1.3. Position: slot 2(CHB).

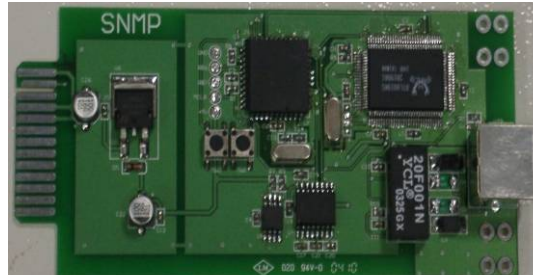

6.5.2. Net Agent II Internal Card

6.5.2.1. For installation, please refer to the user's manual attached with the card.

6.5.2.2. Installation

6.5.2.3. Position: slot 2(CHB).



6.6. The Installation of those Interface Cards

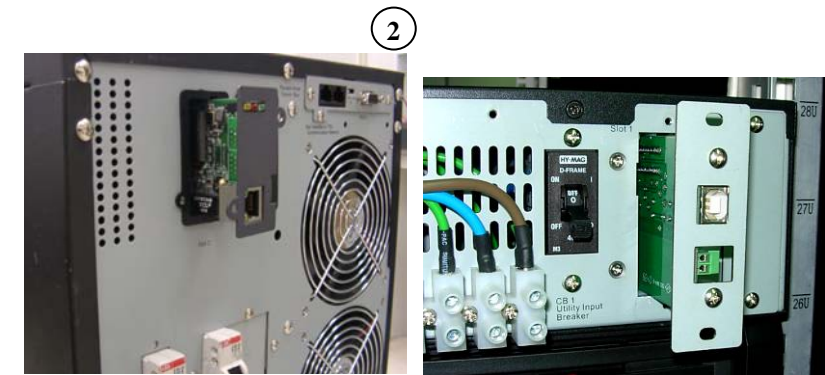
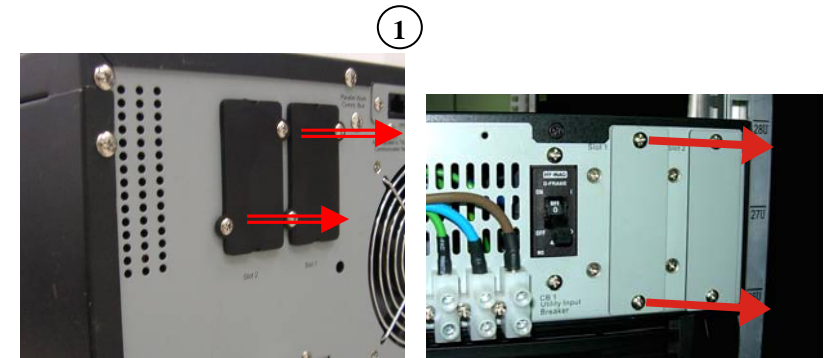

7. Replacing Battery

Qualified personnel allowed only.

1. Unscrew the bottom of the front panel as indicated in Step 1 as below.
2. Remove the front panel as indicated in Step 2.

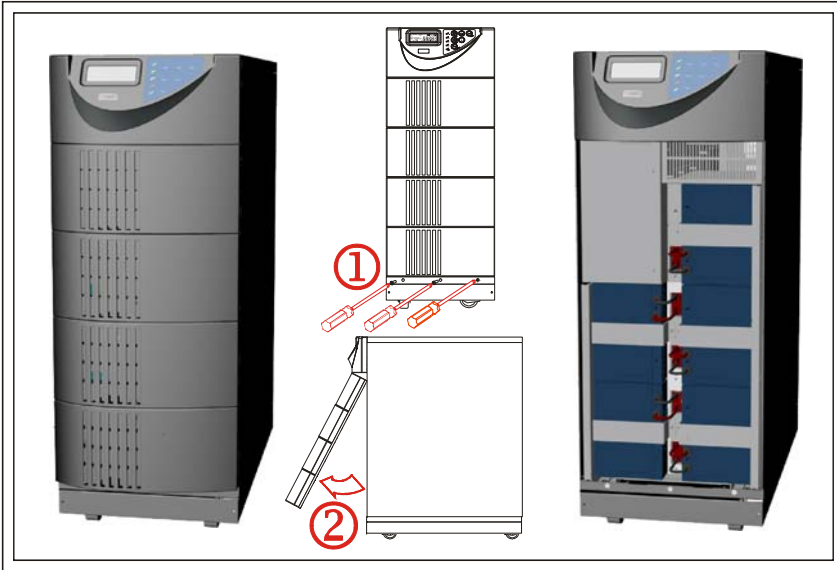

3. Remove the screw of the battery pack fastener as shown in Step 3.
4. Remove the fastener as shown in Step 4.
5. Unplug the hot swappable battery connectors as shown in Step 5.

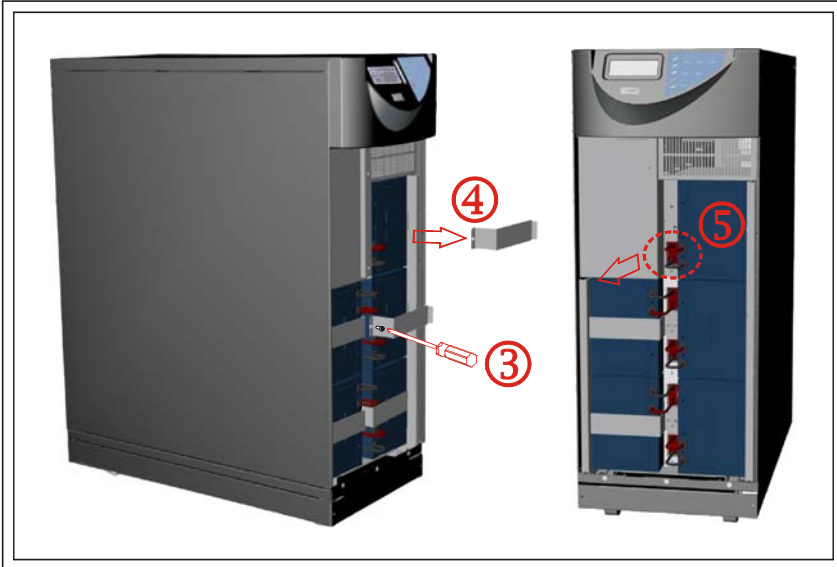

6. Turn the battery pack handle at 90 degree as shown in Step 6.
7. Remove the battery packs from the UPS as shown in Step 7.

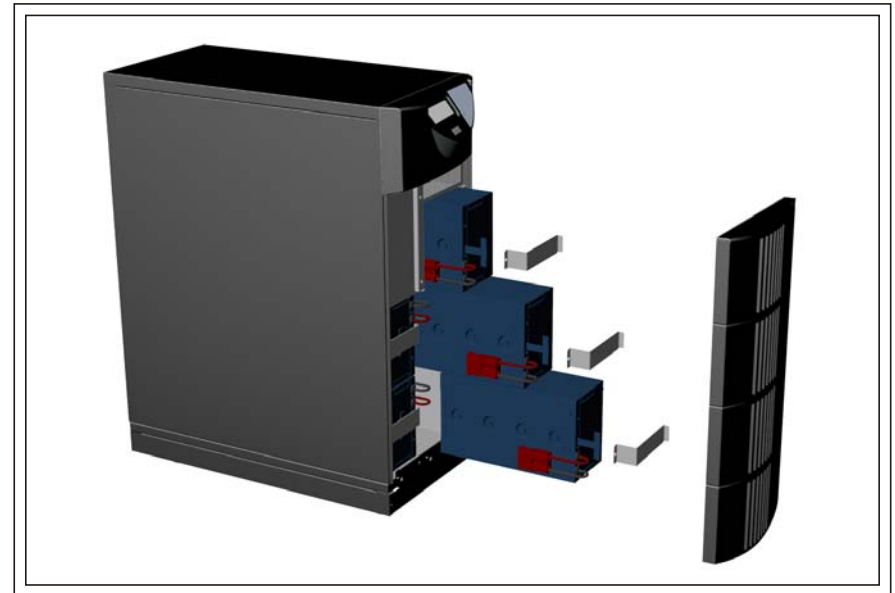

8. Specifications

Model	4500 / 6000	8000 / 8000P 10000 / 10000P
INPUT		
Voltage Window	160~280Vac (1Φ) / 277 – 485Vac (3Φ) *	
Frequency	45 ~ 65 Hz	
Phase/Wire	Single, Line + Neutral + Ground	
Power Factor	Up to 0.99 at 100% Linear Load	
Current THD (100% linear load)	<6% **	
OUTPUT		
Voltage Window	220/230/240Vac Selectable(208/120Vac optional)	
Voltage Adjustment	±0%; ±1%; ±2%; ±3%	
Voltage Regulation	±2%	
Capacity	4500VA / 3150W 6000VA / 4200W	8000VA / 5600W 10000VA / 7000W
Rated Power Factor	0.7 Lagging	
Wave Form	Sine Wave, THD<3%(no load to full load)	
Frequency Stability	±0.2%(Free Running)	
Frequency Regulation	±1%; ±3%	
Transfer Time	0ms	
Crest Factor	3:1	
Efficiency(AC to AC, Normal)	Up to 91%	
Efficiency(AC to AC, ECO)	Up to 97%	Up to 93%
Autonomy	>=8 min.	>=5 min.
DC Start	Yes	
BATTERY		
Type	Sealed Lead Acid Maintenance Free 12V/7AH	Sealed Lead Acid Maintenance Free 8KVA: 7V/9AH 10KVA: 12V/9AH
Quantity	20pcs	
Voltage	240Vdc	
Recharge Time	4 hours to 90%	5 hours to 80%
DISPLAY		
Status On LED + LCD	Line Mode, Backup Mode, ECO Mode, Bypass Supply, Battery Low, Battery Bad/Disconnect, Overload, Transferring with interruption & UPS Fault.	
Readings on LCD	Input Voltage, Input Frequency, Output Voltage, Output Frequency, Load Percentage,	

		Battery Voltage & Inner Temperature.	
Self-Diagnostics		Upon Power-on, Front Panel Setting & Software Control, 24-hour routine checking	
ALARMS			
Audible and Visual		Line Failure, Battery Low, Transfer to Bypass, System Fault Conditions	
PHYSICAL			
Dimensions (WxDxH)mm	Tower model	290x645x748 (without transformer)	
	RT model	290x645x748 (with transformer)	290x645x881 (with transformer)
		440x680x88	440x680x132
Input/Output Connection		Hardwire	
External Battery Connection		Plug-in & Play	
Net Weight (Kgs), (without isolation transformer**)	Tower model Standard Unit/Hot Swappable unit	86/112	87/113 (8K) 92/118 (8KP) 96/122 (10K) 101/127 (10KP)
	RT model	24 kg	45Kg
Heat Dissipation	Tower & RT model (without Isolated Transformer at full Linear Load)	< 450W	< 600W (10K) <550W (10KP)
	Tower model (with Isolated Transformer at Full Linear Load)	< 615W	<1100W (10K) <1050W (10KP)
Leakage Current		< 3mA at Full Load	
Marks		CE, cUL, UL	

* (160~176Vac for 1-phase input model or 277~305Vac for 3-phase input model at <75% load)

** 3-phase input model <30%

** Isolation transformer: net 53kgs for 6000VA, 10000VA

