

Panasonic®

Operating Instructions

Biomedical Freezer

MDF-U334

MDF-U334 Series

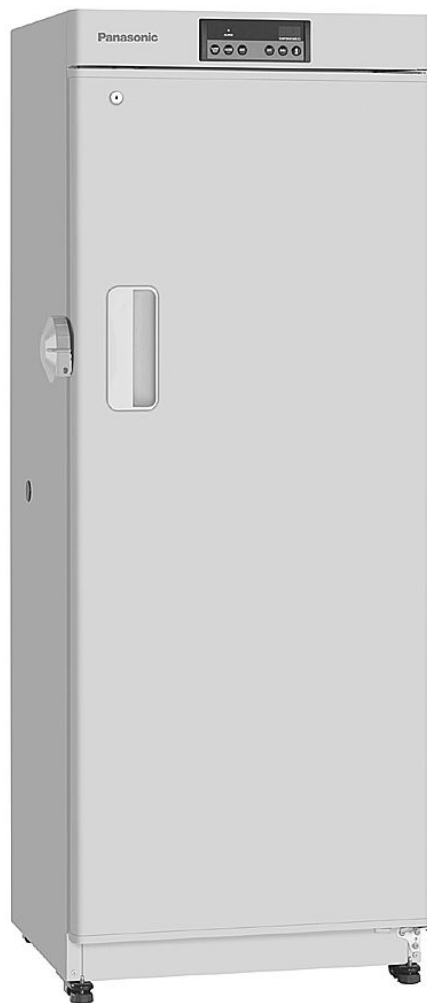

Please read these instructions carefully before using this product, and save this operating instructions for future use.

See page 33 for all Model Numbers.

CONTENTS

INTRODUCTION	P. 2
PRECAUTIONS FOR SAFE OPERATION	P. 3
ENVIRONMENTAL CONDITIONS	P. 7
FREEZER COMPONENTS	P. 8
Control panel	P. 10
INSTALLATION SITE	P. 11
INSTALLATION	P. 12
START-UP OF UNIT	P. 13
CHAMBER TEMPERATURE SETTING	P. 13
KEY LOCK FUNCTION	P. 14
REMOTE ALARM TERMINAL	P. 14
ALARM TEMPERATURE SETTING	P. 15
SETTING OF ALARM RESUME TIME	P. 17
ALARMS & SAFETY FUNCTIONS	P. 18
ROUTINE MAINTENANCE	P. 19
Cleaning of cabinet	P. 19
Defrosting	P. 19
TROUBLESHOOTING	P. 20
DISPOSAL OF UNIT	P. 21
Recycle of battery	P. 21
Decontamination of unit	P. 21
DISPOSAL OF BATTERY	P. 26
TEMPERATURE RECORDER (OPTION)	P. 27
Installation of temperature recorder	P. 27
Setting of MTR-4015LH	P. 28
Setting of MTR-G85A or MTR-G85C	P. 30
SPECIFICATIONS	P. 32
PERFORMANCE	P. 33
SAFETY CHECK SHEET	P. 34

INTRODUCTION

- Read this operating instructions carefully before using the appliance and follow the instructions for safety operation.
- Our company never guarantee any safety if the appliance is used for any objects other than intended use or used by any procedures other than those mentioned in this operating instructions.
- Keep this operating instructions in an adequate place to refer to it as necessary.
- The contents of the operating instructions will be subjected to change without notice due to the improvement of performance or functions.
- Contact our sales representative or agent if any page of the operating instructions is lost or page order is incorrect.
- Contact our sales representative or agent if any point in this operating instructions is unclear or if there are any inaccuracies.
- No part of this operating instructions may be reproduced in any form without the expressed written permission of our company.

CAUTION

Our company guarantees the product under certain warranty conditions. Our company in no way shall be responsible for any loss of content or damage of content.

PRECAUTIONS FOR SAFE OPERATION

It is imperative that the user complies with this operating instructions as it contains important safety advice.



Items and procedures are described so that you can use this unit correctly and safely. If the precautions advised are followed, this will prevent possible injury to the user and any other person.

Precautions are illustrated in the following way:

 WARNING
Failure to observe WARNING signs could result in a hazard to personnel possibly resulting in serious injury or death.





 CAUTION
Failure to observe CAUTION signs could result in injury to personnel and damage to the unit and associated property.

Symbol shows;

-  this symbol means caution.
-  this symbol means an action is prohibited.
-  this symbol means an instruction must be followed.

Be sure to keep this operating instructions in a place accessible to users of this unit.









Some warning and/or caution labels are attached on the unit. Following shows the description of such labels.

	This label is on the cover in which the electrical components of high voltage are enclosed to prevent the electric shock. The cover should be removed by a qualified engineer or a service personnel only.
	This symbol means attention or refer to document.
	This symbol means earth.
	This symbol means power switch "ON".
	This symbol means power switch "OFF".

< Label on the unit >	
	This mark is labeled on the cover in which the electrical components of high voltage are enclosed to prevent the electric shock. The cover should be removed by a qualified engineer or a service personnel only.













PRECAUTIONS FOR SAFE OPERATION

WARNING

-  **Do not use the unit outdoors.** Current leakage or electric shock may result if the unit is exposed to rain water.
-  **Only qualified engineers or service personnel should install the unit.** The installation by unqualified personnel may cause electric shock or fire.
-  **Install the unit on a sturdy floor and take an adequate precaution to prevent the unit from turning over.** If the floor is not strong enough or the installation site is not adequate, this may result in injury from the unit falling or tipping over.
-  **Never install the unit in a humid place or a place where it is likely to be splashed by water.** Deterioration of the insulation may result which could cause current leakage or electric shock.
-  **Never install the unit in a flammable or volatile location.** This may cause explosion or fire.
-  **Never install the unit where acid or corrosive gases are present** as current leakage or electric shock may result due to corrosion.
-  **Always ground (earth) the unit to prevent electric shock.** If the power supply outlet is not grounded, it will be necessary to install a ground by qualified engineers.
-  **Never ground the unit through a gas pipe, water main, telephone line or lightning rod.** Such grounding may cause electric shock in the case of an incomplete circuit.
-  **Connect the unit to a power source as indicated on the rating label attached to the unit.** Use of any other voltage or frequency other than that on the rating label may cause fire or electric shock.
-  **Never store volatile or flammable substances** in this unit if the container cannot be sealed. These may cause explosion or fire.
-  **Do not insert metal objects such as a pin or a wire into any vent, gap or any outlet on the unit.** This may cause electric shock or injury by accidental contact with moving parts.
-  **Use this unit in safe area when treating the poison, harmful or radiate articles.** Improper use may cause bad effect on your health or environment.
-  **Turn off the power switch (if provided) and disconnect the power supply to the unit prior to any repair or maintenance** of the unit in order to prevent electric shock or injury.
-  **Do not touch any electrical parts (such as power supply plug) or operate switches with a wet hand.** This may cause electric shock.

PRECAUTIONS FOR SAFE OPERATION







WARNING

-  **Ensure you do not inhale or consume medication or aerosols** from around the unit at the time of maintenance. These may be harmful to your health.
-  **Never splash water directly onto the unit** as this may cause electric shock or short circuit.
-  **Never put containers with liquid on the unit** as this may cause electric shock or short circuit when the liquid is spilled.
-  **Never bind, process, or step on the power supply cord, or never damage or break the power supply plug.** A broken supply cord or plug may cause fire or electric shock.
-  **Do not use the supply cord if its plug is loose.** Such supply cord may cause fire or electric shock.
-  **Never disassemble, repair, or modify the unit yourself.** Any such work carried out by an unauthorized person may result in fire, or electric shock or injury due to a malfunction.
-  **Disconnect the power supply plug if there is something wrong with the unit.** Continued abnormal operation may cause electric shock or fire.
-  **When removing the plug from the power supply outlet, grip the power supply plug, not the cord.** Pulling the cord may result in electric shock or fire by short circuit.
-  **Disconnect the power supply plug** before moving the unit. Take care not to damage the power cord. A damaged cord may cause electric shock or fire.
-  **Disconnect the power plug when the unit is not used for long periods.** Keeping the connection may cause electric shock, current leakage, or fire due to the deterioration of insulation.
-  If the unit is to be stored unused in an unsupervised area for an extended period, **ensure that children do not have access and that doors cannot be closed completely.**
-  **The disposal of the unit should be accomplished by appropriate personnel.** Remove doors to prevent accidents such as suffocation.
-  **Do not put the packing plastic bag within reach of children** as suffocation may result.

PRECAUTIONS FOR SAFE OPERATION



CAUTION

-  **Use a dedicated power source** (a dedicated circuit with a breaker) as indicated on the rating label attached to the unit. A branched circuit may cause fire resulting from abnormal heating.
-  **Connect the power supply plug to the power source firmly after removing the dust on the plug.** A dusty plug or improper insertion may cause a heat or ignition.
-  **Never store corrosive substances such as acid or alkali** in this unit if the container cannot be sealed. These may cause corrosion of inner components or electric parts.
-  **Check the setting when starting up of operation after power failure or turning off of power switch.** The stored items may be damaged due to the change of setting.
-  **Be careful not to tip over the unit** during movement to prevent damage or injury.
-  **Prepare a safety check sheet** when you request any repair or maintenance for the safety of service personnel.

ENVIRONMENTAL CONDITIONS

This equipment is designed to be safe at least under the following conditions (based on the IEC 61010-1):

- Indoor use;
- Altitude up to 2000 m;
- Ambient temperature 5°C to 40°C;
- Maximum relative humidity 80% for temperature up to 31°C decreasing linearly to 50% relative humidity at 40°C;
- Mains supply voltage fluctuations up to $\pm 10\%$ of the nominal voltage;
- Transient overvoltages up to the levels of OVERVOLTAGE CATEGORY II;
- Temporary OVERVOLTAGES occurring on the mains supply;
- Applicable pollution degree of the intended environment (POLLUTION DEGREE 2 in most cases);

FREEZER COMPONENTS

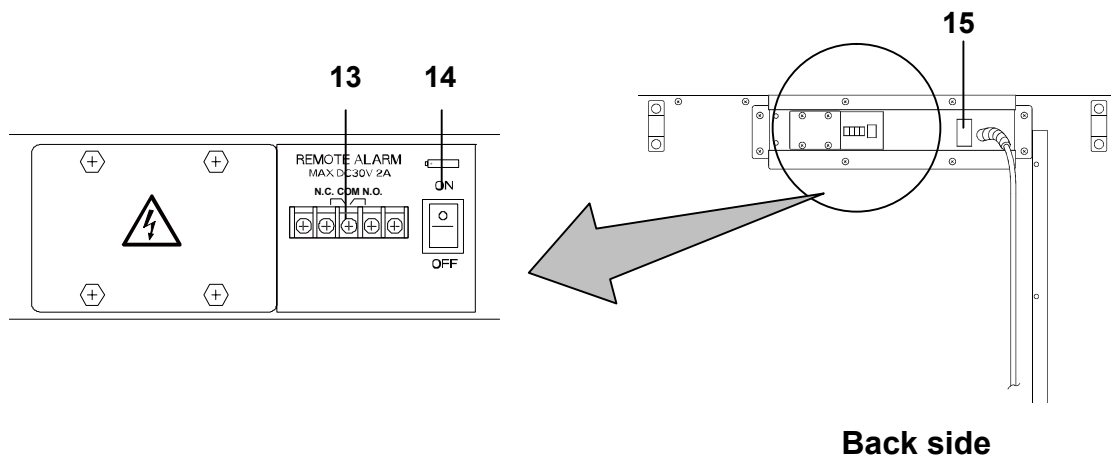
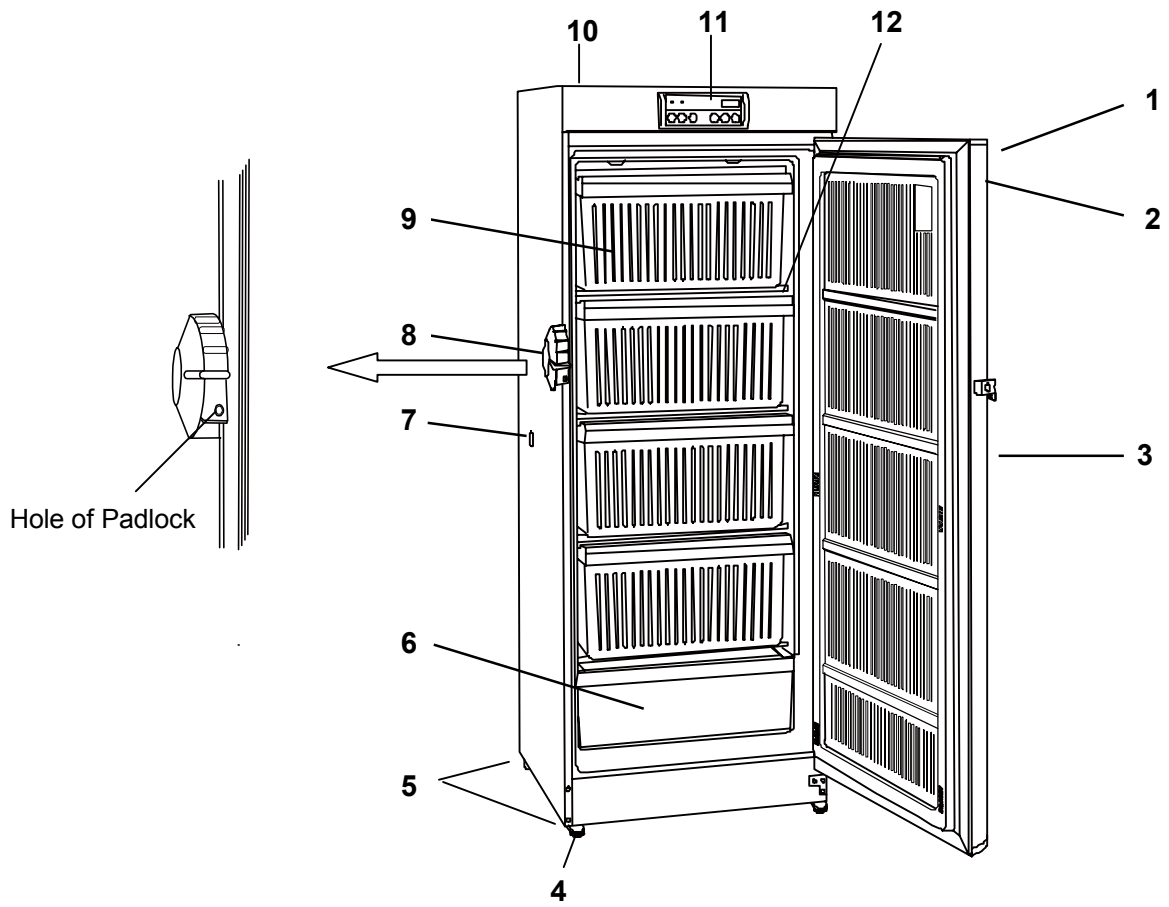

FREEZER COMPONENTS

1. **Lock:** By turning to 180 degree to counterclockwise with a key, the door can be locked.
 2. **Door:** To open the door, grip the handle.
 3. **Handle:** Always grip the handle to open the door.
 4. **Leveling foot:** Serves to adjust the height and to settle the frame evenly.
 5. **Caster:** four casters are provided for easy movement. Separate the front two casters from the floor by adjusting the leveling legs at the time of installation.
 6. **Defrost water vessel & storage container:** The container can be used to collect the defrosted water when defrosting.
 7. **Access port:** This is used for leading the measuring cable from the freezing chamber to the outside.
 8. **Door latch:** To lock the door, turn this latch downward. A padlock is also available.
 9. **Storage container:** Made of styrol resin. Be careful not to damage the container by a metal scraper at the time of defrosting.
-  **WARNING**
Fix the storage container securely. Incomplete installation may cause injury or damage.
Never touch the storage items with wet hands. Touching with the wet hands may cause frostbite
10. **Space for temperature recorder:** A temperature recorder (optional part) can be attached here. See page 27 "TEMPERATURE RECORDER (OPTION)".
 11. **Control panel:** To display the temperature setting and running condition. See page 10 for details.
 12. **Defrost mark:** When this is hidden by frost, defrost the freezer. See to page 19 for instructions.
 13. **Remote alarm terminal:** Used to notify an alarm condition of the unit to remote location. See page 14 for details.
 14. **Battery switch:** Switch for battery used for power failure alarm. Always keep ON. Turn the switch OFF when the unit is in no use for a long period (more than one month).
 15. **Power switch:** Switch for the freezer. This switch also activates as an over-current breaker (15 A).

FREEZER COMPONENTS

Control panel

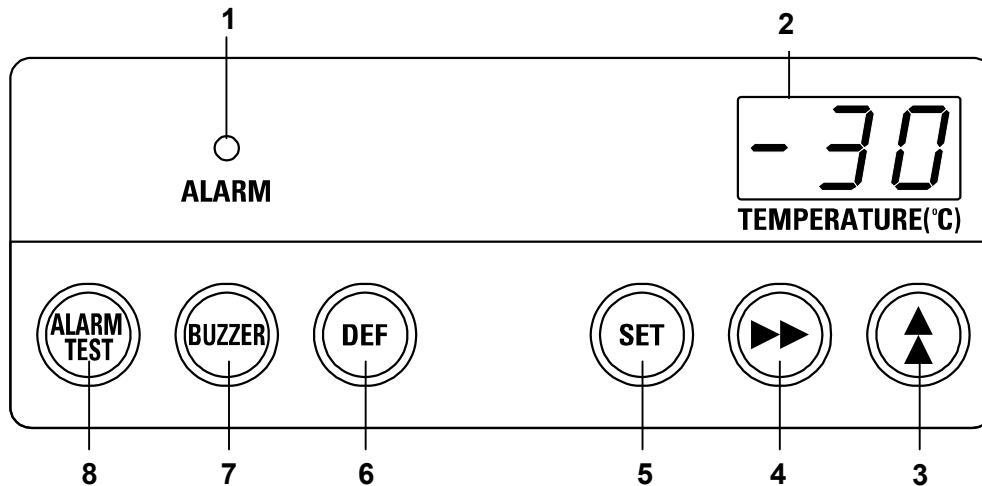

1. Alarm lamp (ALARM): This lamp is flashed during alarm condition.

2. Digital temperature indicator: This indicator shows the present chamber temperature or set temperature.

3. Numerical value shift key (▲): Pressing this key in the setting mode causes the numerical value to shift. ON-OFF of key lock can be selected by pressing this key in the key lock mode.

4. Digit shift key (▶▶): Pressing this key in the setting mode causes the changeable digit to shift. Key lock mode is led by pressing this key for more than 5 seconds in the temperature display mode. Refer to page 14 for the key lock.

5. Set key (SET): Temperature setting mode is led by pressing this key. Once the key is pressed, the changeable digit is flashed. Pressing this key again after setting desired temperature, the setting is stored into computer memory. If there is no key operation for ninety seconds during the temperature setting mode, the temperature setting mode is invalid automatically. See page 13 for the details.

6. Defrost key (DEF): By pressing this key for five seconds, the refrigerating operation is stopped. Pressing this key again after defrosting leads resumption of the operation.

Note: The refrigerating operation never resume automatically after defrosting.

7. Alarm buzzer stop key (BUZZER): To silence the audible alarm, press this key. The remote alarm is also stopped by pressing this key. (The buzzer cannot be stopped during alarm testing.)

8. Alarm test key (ALARM TEST): Test key for alarm device. By pressing this key, the alarm lamp is flashed, remote alarm is activated and buzzer sound. This means all alarm function operate correctly.

INSTALLATION SITE

To operate this unit properly and to obtain maximum performance, install the unit in a location with the following conditions:

■ **A location not subjected to direct sunlight**

Do not install the unit under direct sunlight. Installation in a location subjected to direct sunlight cannot obtain the intended performance.

■ **A location with adequate ventilation**

Leave at least 10 cm around the unit for ventilation. Poor ventilation will result in a reduction of the performance and consequently the failure.

■ **A location away from heat generating sources**

Avoid installing the unit near heat-emitting appliances such as a heater or a boiler etc. Heat can decrease the intended performance of the unit.

■ **A location with little temperature change**

Install the unit under stable ambient temperature. The allowable ambient temperature is between -5°C and $+35^{\circ}\text{C}$.

■ **A location with a sturdy and level floor**

Always install the unit on a sturdy and level floor. The uneven floor or tilted installation may cause failure or injury. Install the unit in stable condition to avoid the vibration or noise. Unstable condition may cause vibration or noise.

⚠ WARNING

Install the unit on a sturdy floor. If the floor is not strong enough or the installation site is not adequate, this may result in injury from the unit falling or tipping over.

Select a level and sturdy floor for installation. This precaution will prevent the unit from tipping. Improper installation may result in water spillage or injury from the unit tipping over.

■ **A location not prone to high humidity**

Install the unit in the ambient of 80% R.H. or less humidity. Installation under high humidity may cause current leakage or electric shock.

⚠ WARNING

Do not use the unit outdoors. Current leakage or electric shock may result if the unit is exposed to rain water.

Never install the unit in a humid place or a place where it is likely to be splashed by water. Deterioration of the insulation may result which could cause current leakage or electric shock.

■ **A location without flammable or corrosive gas**

Never install the unit in a flammable or volatile location. This may cause explosion or fire or may result in the current leakage or electric shock by the corrosion of the electrical components.

■ **A location without the possibility of anything fall**

Avoid installing the unit in the location where anything can fall down onto the unit. This may cause the breakdown or failure of the unit.

INSTALLATION

1. Removing the packaging materials and tapes

Remove all transportation packaging materials and tapes. Open the doors and ventilate the unit. If the outside panels are dirty, clean them with a diluted neutral dishwashing detergent. (Undiluted detergent can damage the plastic components. For the dilution, refer to the instruction of the detergent.) After the cleaning with the diluted detergent, always wipe it off with a wet cloth. Then wipe off the panels with a dry cloth.

Note:

Remove the cable tie for banding the power supply cord. Prolonged banding may cause the corrosion of the cord coating

2. Adjusting the leveling foot

Extend the leveling feet by rotating them counterclockwise to contact them to the floor. Ensure the unit is level.

3. Fixing the unit

Two fixtures are attached to the rear of the frame. Fix the frame to the wall with these fixtures and rope or chain.

4. Ground (earth)

The ground (earth) is for preventing the electric shock in the case of the electrical insulation is somehow degraded. Always ground the unit at the time of installation.

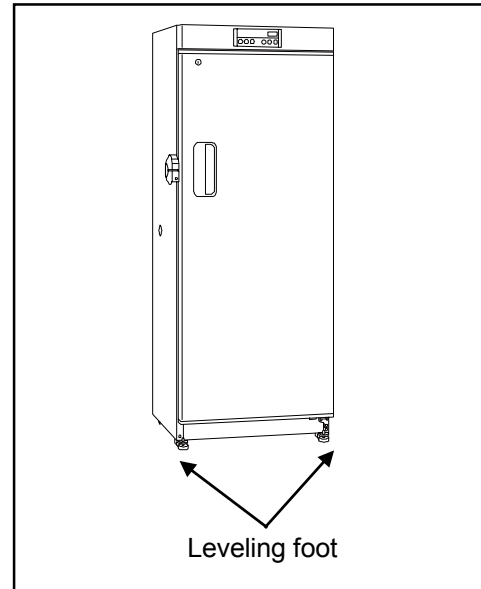

⚠️ WARNING

Use a power supply outlet with ground (earth) to prevent electric shock. If the power supply outlet is not grounded, it is necessary to install a ground by qualified engineers.

Never ground the unit through a gas pipe, water main, telephone line or lightning rod. Such grounding may cause electric shock in the case of an incomplete circuit.

5. Installing the short circuit breaker

This product is to be connected to a dedicated circuit protected by branch circuit breaker. Contact our sales representative or agent.

START-UP OF UNIT

Follow the procedures for the initial and consequent operations of the unit.



1. Connect the power cord to the dedicated outlet with appropriate rating.
2. Turn on the power switch.
3. Turn on the battery switch. The alarm buzzer sometimes operates. In this case, stop the buzzer by pressing the alarm buzzer stop key (BUZZER).
4. Set the chamber temperature to the desired temperature.
5. Allow the chamber temperature to fall to the desired temperature. Check the chamber temperature on the digital temperature indicator.
6. Press the alarm test key (ALARM TEST) and check that the alarm lamp blinks and alarm buzzer activates. Also, the remote alarm is activated.
Note: E09 is displayed on the digital temperature indicator when the battery switch is OFF.
7. Begin slowly placing items into the chamber to minimize the temperature rise.

CHAMBER TEMPERATURE SETTING

Table 1 shows the basic procedure for setting the chamber temperature. Perform key operations in the sequence indicated in the table. The example in the table is based on the assumption that the desired temperature is -25°C.

Note: Factory setting is the chamber temperature -30°C.

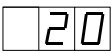
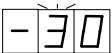
Table 1 Basic operation sequence (Example: Chamber temperature -25°C)

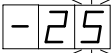
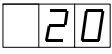
	Description of operation	Key operated	Indication after operation
1	Connect the power cord to the outlet. Turn the power switch ON.	----	The current chamber temperature is displayed. 
2	Press set key.	SET	The second digit of the temperature indicator flashes. 
3	Set the temperature to 25 with the digit shift key and the numerical value shift key.	 	By pressing the key, settable digits moves.  By pressing the key, the numerical value of the settable digit increases.
4	Press set key.	SET	The current chamber temperature is displayed. 





- Although the value of the chamber temperature setting can range from -18°C to -35°C, the guaranteed temperature when there is no load is -30°C when the external temperature is 30°C.

KEY LOCK FUNCTION

This unit is provided with the key lock function. When the key lock is ON, change of temperature setting through the key pad is not available. The key lock is set in OFF at the factory.

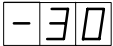
Display	Mode	Function
L 0	Key lock is OFF	Enable to change of temperature setting
L 1	Key lock is ON	Disable to change of temperature setting

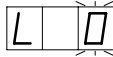
Table 2 Procedure for key lock setting (change from key lock OFF to key lock ON)

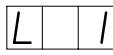
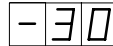
	Description of operation	Key operated	Indication after operation
1		----	The current chamber temperature is displayed. 
2	Press digit shift key for 5 seconds.		The right digit is flashed. 
3	Press numerical value shift key and scroll the figure to 1.		When pressed, the figure of settable digit increases. 
4	Press set key.	SET	The key lock is set to ON. The current chamber temperature is displayed. 

- The key lock only works with the chamber temperature setting and the defrost key (DEF).

REMOTE ALARM TERMINAL

WARNING

Always disconnect the power supply cord before connecting an alarm device to the remote alarm terminal.

The terminal of the remote alarm is installed at the upper side of the unit. The alarm is outputted from this terminal. Contact capacity is DC 30 V, 2 A.

Contact output:

	between COM. and N.O.	between COM. and N.C.
At normal	Open	Close
At abnormal	Close	Open

Note:

- The buzzer is silenced by pressing buzzer stop key (BUZZER) on the control panel during alarm condition. (A remote alarm is continuing the operation.)

The buzzer will be activated again after certain suspension if the alarm condition is continued.

- The alarm is actuated when the power supply plug is disconnected from the outlet or the power switch is OFF.

Use a twisted sealed wire for the connection.
Type UL2343, UL2448, UL2464, UL2552, UL 2623
Length: thirty meter max.

ALARM TEMPERATURE SETTING

This unit is provided with both high and low temperature alarms. The temperature at which the alarm is activated may be changed.

The available set range for high temperature alarm is between +5°C and +15°C, and -5°C and -15°C for low temperature alarm against the set temperature.

Note: The temperature alarm is set at $\pm 10^\circ\text{C}$ of the set temperature at the factory.

Display	Mode	Function
F01	High temperature alarm set	See Table 3 on page 15
F02	Low temperature alarm set	See Table 4 on page 16

As an example, Table 3 shows the procedure to set the high temperature alarm so that the alarm can activate when the chamber temperature is 5°C higher than the set temperature.

Table 4 shows the procedure to set the low temperature alarm so that the alarm can activate when the chamber temperature is 5°C lower than the set temperature.

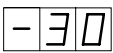



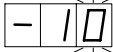

Table 3 Procedure for setting high temperature alarm

	Description of operation	Key operated	Indication after operation
1		----	The current chamber temperature is displayed.
2	Press numerical value shift key for five seconds.		The first digit is flashed.
3	Press numerical value shift key and scroll the figure to 1.		When pressed, the figure of settable digit increases.
4	Press set key.	SET	The right digit is flashed.
5	Set the temperature to 005 with the digit shift key and numerical value shift key.		Pressing the key shifts the digit which can be set.
			When pressed, the figure of settable digit increases.
6	Press set key.	SET	Alarm temperature is memorized and the current chamber temperature is displayed.

- The set mode returns to the temperature display mode automatically when ninety seconds has passed without any key operation. In this case, any setting before pressing set key (SET) is not memorized.

ALARM TEMPERATURE SETTING

Table 4 Procedure for setting low temperature alarm

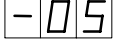
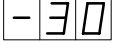
	Description of operation	Key operated	Indication after operation
1		----	The current chamber temperature is displayed. 
2	Press numerical value shift key for five seconds.		The right digit is flashed. 
3	Press numerical value shift key and scroll the figure to 2.		When pressed, the figure of settable digit increases. 
4	Press set key.	SET	The right digit is flashed. 
5	Set the temperature to -05 with the digit shift key and numerical value shift key.		Pressing the key shifts the digit which can be set.
			When pressed, the figure of settable digit increases. 
6	Press set key.	SET	Alarm temperature is memorized and the current chamber temperature is displayed. 

- The set mode returns to the temperature display mode automatically when ninety seconds has passed without any key operation. In this case, any setting before pressing set key (SET) is not memorized.

SETTING OF ALARM RESUME TIME

The alarm buzzer and remote alarm is stopped by pressing alarm buzzer stop key (BUZZER) on the control panel during alarm condition. The buzzer and remote alarm terminal will be activated again after certain suspension if the alarm condition is continued. The suspension time can be set by following the procedure shown in the Table 5 below.

The example in the table is based on the assumption that the desired duration is twenty minutes.

Note: The duration is set in thirty minutes at the factory.

Table 5 Setting procedure for alarm resuming time (change from 30 minutes to 20 minutes)

	Description of operation	Key operated	Indication after operation
1		----	The current chamber temperature is displayed.
2	Press numerical value shift key for 5 seconds.		The first digit is flashed.
3	Set the figure to F25 with the digit shift key and numerical value shift key.		Pressing the key shifts the digit which can be set.
			When pressed, the figure of settable digit increases.
4	Press set key.	SET	The current resume time is displayed. The middle digit is flashed.
5	Set the figure to 020 with the numerical value shift key.		When pressed, the figure of settable digit increases.
6	Press set key.	SET	Alarm resume time is memorized and the current chamber temperature is displayed.

- The settable alarm resume time is 10, 20, 30, 40, 50, or 60 minutes (The setting is 010, 020, 030, 040, 050, or 060). The buzzer would not resume if the resume time is set in 000.
- The setting of alarm resume time cannot be changed during the defrosting.
- The buzzer and remote alarm during power failure or alarm testing cannot be silenced.
- The set mode returns to the temperature display mode automatically when ninety seconds has passed without any key operation. In this case, any setting before pressing set key (SET) is not memorized.

ALARMS & SAFETY FUNCTIONS

This unit has the alarms and safety functions shown in Table 6, and also self diagnostic functions.

Table 6 Alarms and safety functions

Alarm & Safety	Situation	Indication	Buzzer	Safety operation
High temperature alarm	If the chamber temperature is higher than the temperature at which the high temperature alarm is activated.	Alarm lamp is flashed. Digital temperature indicator is flashed.	Intermittent tone with 15 minutes delay.	Remote alarm with 15 minutes delay.
Low temperature alarm	If the chamber temperature is lower than the temperature at which the low temperature alarm is activated.	Alarm lamp is flashed. Digital temperature indicator is flashed.	Intermittent tone with 15 minutes delay.	Remote alarm with 15 minutes delay.
Power failure alarm	In the case of power failure. When power switch is turned OFF. When the power to the unit is disconnected.	Alarm lamp is flashed.	Intermittent tone	Remote alarm.
Auto-return	When there is no key pressing in each setting mode for 90 seconds.	Chamber temperature is displayed.	----	Finishing of each setting mode.
Key lock	When the key lock is "ON".	----	----	Change of setting is disable.
Battery switch check	When battery switch is OFF at the time of alarm test.	Alarm lamp is flashed. E09 is flashed.	Intermittent tone	Remote alarm.
Thermal sensor Abnormality	If the thermal sensor is disconnected.	Alarm lamp is flashed. E01 and chamber temp. are displayed alternately.	Intermittent tone	Remote alarm. Continuous running.
	If the thermal sensor is short-circuited.	Alarm lamp is flashed. E02 and chamber temp. are displayed alternately.	Intermittent tone	Remote alarm. Continuous running.
Ambient sensor abnormality	If the ambient temperature sensor is disconnected.	Alarm lamp is flashed. E03 and chamber temp. are displayed alternately.	Intermittent tone	Remote alarm.
	If the ambient temperature sensor is short-circuited.	Alarm lamp is flashed. E04 and chamber temp are displayed alternately.	Intermittent tone	Remote alarm.
Compressor protection sensor abnormality	If the compressor protection temperature sensor is disconnected.	Alarm lamp is flashed. E05 and chamber temp. Are displayed alternately.	Intermittent tone	Remote alarm. Normal operation.
	If the compressor protection temperature sensor is short circuited.	Alarm lamp is flashed. E06 and chamber temp. Are displayed alternately.		
Compressor temp. Abnormality	In the case of failure of compressor cooling fan motor. In the case of abnormal high temp. due to the dust on the condenser. In the case of abnormal high ambient temperature.	E10 and chamber temp. are displayed alternately.	Intermittent tone	Remote alarm. Compressor stops running when the temp reaches about 80°C.
Battery check	When about three years has passed with power switch ON.	_F1 and chamber temp. are displayed alternately.	----	Information only
Fan motor check	When about six years has passed with power switch ON.	_F2 and chamber temp. are displayed alternately.	----	Information only

- The above power failure alarm is available when the battery switch is ON and the battery is charged. If the battery switch is OFF or the battery is discharged, only the remote alarm is activated.
- The power failure alarm can be kept about twelve hours with the battery charged completely. 2-day operation of the freezer is needed to charge the battery full.
- The chamber temperature is displayed for five seconds if the alarm buzzer stop key (BUZZER) is depressed during the power failure alarm. At the same time, the alarm buzzer stops.
- The remote alarm is stopped by pressing alarm buzzer stop key (BUZZER) as the remote alarm is operated in conjunction with the buzzer, except for the power failure alarm.
- After power failure, the operation is resumed with the condition before power failure since the temperature setting and alarm temperature setting are memorized in a nonvolatile memory.
- The following directions are the information of the part replacement (it is recommendation). This is not a trouble.
 - a) The battery for power failure alarm is an article for consumption. It is recommended that the battery will be replaced about every three years. Contact our sales representative or agent at the time of replacement of the battery for recycling.
 - b) Fan motors are expendable supplies. Replace it for about every six years. Contact our sales representative or agent at the time of replacement of the fan motor.

ROUTINE MAINTENANCE

WARNING

Always disconnect the power supply to the unit prior to any repair or maintenance of the unit in order to prevent electric shock or injury.

Ensure you do not inhale or consume medication or aerosols from around the unit at the time of maintenance. These may be harmful to your health.

CAUTION

Always put on the dry gloves to protect the hands at the time of maintenance. No gloves may cause cut of the finger by the edge or corner.

Cleaning of cabinet

- Clean the unit once a month. Regular cleaning keeps the unit looking new.
- Use a dry cloth to wipe off small amounts of dirt on the outside and inside of the unit and all accessories. If the outside panels are dirty, clean them with a diluted neutral dishwashing detergent. (Undiluted detergent can damage the plastic components. For the dilution, refer to the instruction of the detergent.) After the cleaning with the diluted detergent, always wipe it off with a wet cloth. Then wipe off the cabinet or accessories with a dry cloth.
- Never pour water onto or into the unit. Doing so can damage the electric insulation and cause failure.
- The compressor and other mechanical parts are completely sealed. This unit requires absolutely no lubrication.

Defrosting

Defrost the freezer whenever one of the defrost marks shown by 12 in the figure on page 9 is hidden by frost.

Use the scraper provided for removing the frost if the freezer operation must be continued. Pay attention not to impact or damage the inner wall.

1. When defrosting, temporarily move all the contents of containers in the freezer to another low-temperature freezer.
2. Place the empty defrost water vessel & storage container inside the freezer.
3. Press defrost key (DEF) for five seconds to stop the refrigerating operation. While the refrigerating operation is stopped, the current chamber temperature and dF is displayed on the digital temperature indicator alternately.
4. After a several hours, check visually that all defrost was removed completely.
5. Throw out the water that has accumulated in the defrost water vessel & storage container, then wipe the inside of the freezer.
6. Press defrost key (DEF) so that the refrigerating operation can be started.
7. Once the chamber temperature has dropped to the desired temperature, place the original contents back in the freezer chamber.

Note:

- After the defrosting, the refrigerating operation is never resumed automatically. Make sure to press defrost key (DEF) to start the freezer operation after defrosting.

TROUBLE SHOOTING

If the unit malfunctions, check out the following before calling for service.

Malfunction	Check/Remedy
The chamber is not cooled at all	<ul style="list-style-type: none"> ▪ The circuit breaker of power source is active. ▪ The voltage is too low (In this case, call an electrician.) ▪ The power switch is not ON. ▪ The large amount of articles (load) is stored in the chamber at one time. ▪ The freezer is in defrost condition.
The cooling is poor	<ul style="list-style-type: none"> ▪ The ambient temperature is too high. ▪ The door is not closed firmly. ▪ The large amount of frost is built on the chamber wall. ▪ The set temperature is not inputted properly. ▪ The freezer is in the direct sunlight. ▪ There is any heating source near the freezer. ▪ A rubber cap and insulation for the access port are not set correctly. ▪ You put too many unfrozen articles into the freezer compartment.
When the unit does not accept changes of temperature setting	<ul style="list-style-type: none"> ▪ The key lock is set in ON mode.
Noise	<ul style="list-style-type: none"> ▪ The freezer is not installed on the sturdy floor. ▪ The freezer is not leveled with the leveling feet. ▪ There is anything touching the frame. ▪ The freezer is in the status immediately after start up. <p>The unit sometimes causes a noise when the chamber temperature is high due to the large load. The noise gets less and less accompanying with the cooling of the chamber.</p>

If the malfunction is not eliminated after checking the above items, or the malfunction is not shown in the above table, contact our sales representative or agent.

DISPOSAL OF UNIT

WARNING

If the unit is to be stored unused in an unsupervised area for an extended period **ensure that children do not have access and doors cannot be closed completely.**

The disposal of the unit should be accomplished by appropriate personnel. Always remove doors to prevent accidents such as suffocation.

Recycle of battery



The unit contains a rechargeable battery. The battery is recyclable. At the end of its useful life, check with your local solid waste officials for options or proper disposal.



* Label indication is obliged to comply with Taiwanese battery regulation.

Decontamination of unit

Before disposing a biomedical freezer with biohazardous danger, decontaminate the biomedical freezer to the extent possible by the user.

DISPOSAL OF UNIT

(English)

FOR EU USERS

The symbol mark and recycling systems described below apply to EU countries and do not apply to countries in other areas of the world.

Your Panasonic product is designed and manufactured with high quality materials and components which can be recycled and/or reused.

The symbol mark means that electrical and electronic equipment, batteries and accumulators, at their end-of-life, should be disposed of separately from your household waste.

Note:

If a chemical symbol is printed beneath the symbol mark, this chemical symbol means that the battery or accumulator contains a heavy metal at a certain concentration. This will be indicated as follows: Hg: mercury, Cd: cadmium, Pb: lead

In the European Union there are separate collection systems for used electrical and electronic equipment, batteries and accumulators.

Please, dispose of them correctly at your local community waste collection/recycling centre.

Please, help us to conserve the environment we live in!

(German)

Für EU-Staaten

Das Symbol und das erwähnte Wiederverwertungssystem gelten nur für die Länder der EU und nicht für andere Länder oder Gebiete in der Welt.

Die Produkte von Panasonic werden aus hochwertigen Materialien und Komponenten gefertigt, die sich wieder verwenden lassen.

Das Symbol bedeutet, dass elektrische oder elektronische Geräte, Batterien und Akkus am Ende ihrer Lebensdauer nicht im Haushaltsmüll entsorgt werden dürfen.

Hinweis:

Ein chemisches Zeichen unter dem Symbol bedeutet, dass die Batterie bzw. der Akku Schwermetalle in gewissen Konzentrationen enthält. Die Metalle werden wie folgt bezeichnet: Hg: Quecksilber, Cd: Kadmium, Pb: Blei

In der Europäischen Union gibt es separate Sammelstellen für elektrische und elektronische Geräte, Batterien und Akkus.

Entsorgen Sie solche Geräte bitte richtig in der kommunalen Sammelstelle bzw. im Recyclingzentrum.

Helfen Sie mit, die Umwelt in der wir leben, zu schützen.



DISPOSAL OF UNIT

(French)

POUR LES UTILISATEURS DE UE

Le symbole et les systèmes de recyclage évoqués ci-dessous s'appliquent uniquement aux pays de UE.

Votre produit Panasonic est conçu et fabriqué avec des composants et des matériaux de hautes qualités qui peuvent être recyclés et/ou réutilisés.

Le symbole signifie que les équipements électriques et électroniques, les batteries et les accumulateurs ne doivent pas être mis au rebut avec les déchets domestiques à l'issue de leur durée de vie.

Remarque:

Si un symbole chimique est imprimé sous le symbole, le symbole chimique indique que la batterie ou l'accumulateur contient une certaine concentration de métaux lourds. Les métaux sont indiqués de la manière suivante: Hg: mercure, Cd: cadmium, Pb: plomb.

Il existe différents systèmes de collecte pour les équipements électriques et électroniques, les batteries et les accumulateurs usagés au sein de l'Union européenne.

Veuillez mettre les équipements au rebut de manière correcte, auprès de votre centre de recyclage/de collecte des déchets local.

Aidez-nous à préserver l'environnement dans lequel nous vivons!

Les machines ou appareils électriques et électroniques contiennent fréquemment des matières qui, si elles sont traitées ou éliminées de manière inappropriée, peuvent s'avérer potentiellement dangereuses pour la santé humaine et pour l'environnement.

Cependant, ces matières sont nécessaires au bon fonctionnement de votre appareil ou de votre machine. Pour cette raison, il vous est demandé de ne pas vous débarrasser de votre appareil ou machine usagé avec vos ordures ménagères.

(Spanish)

PARA USUARIOS DE LA UNION EUROPEA

El símbolo y los sistemas de reciclado descritos a continuación se aplican para países de la Unión Europea y no se aplica para países en otras áreas del mundo.

Su producto Panasonic fue diseñado y fabricado con materiales de alta calidad y componentes que pueden ser reciclados y/o vueltos a usar.

El símbolo significa que los equipos eléctricos y electrónicos, baterías y acumuladores, al final de su vida útil, debe ser desechados separadamente de sus residuos domiciliarios.

Nota:

Si hay un símbolo químico impreso debajo del símbolo, este símbolo químico significa que la batería o acumulador contiene una cierta concentración de un metal pesado. Esto es indicado de la siguiente manera: Hg: mercurio, Cd: cadmio, Pb: plomo

En la Unión Europea hay sistemas de recolección separados para equipos eléctricos y electrónicos, baterías y acumuladores usados.

Por favor, disponga de ellos correctamente en el centro de recolección de residuos/reciclado de la comunidad de su localidad.

Por favor, ayúdenos a proteger el medio ambiente en que vivimos!



DISPOSAL OF UNIT

(Portuguese)

PARA UTILIZADORES DA UE

O símbolo e os sistemas de reciclagem descritos abaixo aplicam-se aos países da UE e não se aplicam aos países noutras áreas do mundo.

O seu produto Panasonic foi concebido e fabricado com materiais e componentes de elevada qualidade que podem ser reciclados e/ou reutilizados.

O símbolo significa que o equipamento eléctrico e electrónico, baterias e acumuladores, em final de vida, não devem ser deitados fora juntamente com o lixo doméstico.

Atenção:

Se estiver impresso um símbolo químico debaixo do símbolo de , este símbolo químico significa que a bateria ou acumulador contém um metal pesado numa determinada concentração. Estará indicado da seguinte forma: Hg: mercúrio, Cd: cádmio, Pb: chumbo

Na União Europeia existem sistemas de recolha separados para equipamento eléctrico e electrónico, baterias e acumuladores.

Por favor, entregue-os no seu centro de reciclagem/recolha de lixo local.

Por favor, ajude-nos a conservar o ambiente!

(Italian)

PER UTENTI UE

Il simbolo e i sistemi di riciclaggio descritti di seguito si applicano esclusivamente ai paesi dell'UE.

Questo prodotto Panasonic è stato progettato e realizzato con materiali e componenti di elevata qualità che possono essere riciclati e/o riutilizzati.

Il simbolo di riciclaggio mostrato di seguito indica che i dispositivi elettrici ed elettronici, le batterie e gli accumulatori, una volta esauriti, devono essere smaltiti separatamente rispetto ai rifiuti domestici.

Nota:

Se sotto il simbolo di riciclaggio appare un simbolo chimico, esso sta ad indicare che la batteria o l'accumulatore contengono metalli pesanti a determinate concentrazioni. Questo viene specificato come segue: Hg: mercurio, Cd: cadmio, Pb: piombo.

Nell'Unione europea esistono diversi sistemi per la raccolta dei rifiuti speciali quali i dispositivi elettrici ed elettronici, le batterie e gli accumulatori.

Si raccomanda di provvedere allo smaltimento di tali rifiuti secondo quanto previsto dalle normative vigenti in materia.

Aiutaci a conservare l'ambiente!



DISPOSAL OF UNIT

(Dutch)

VOOR GEBRUIKERS IN DE EU

Het symbool en de recycleersystemen die hieronder beschreven worden, zijn van toepassing op de landen in de EU en zijn niet van toepassing op landen in andere delen van de wereld.

Uw Panasonic product is ontworpen en gemaakt met materialen en onderdelen van hoge kwaliteit, die gerecycleerd en opnieuw gebruikt kunnen worden.

Het symbool betekent dat elektrische en elektronische apparatuur, batterijen en accu's aan het eind van hun leven apart van uw huisafval weggegooid moeten worden.

Let op:

Indien een chemisch symbool afgedrukt staat onder het symbool, betekent dit chemisch symbool dat de batterij of accu een zwaar metaal met een bepaalde concentratie bevat. Dit wordt als volgt aangegeven: Hg: kwik, Cd: cadmium, Pb: lood

In de Europese Unie zijn afzonderlijke inzamelingsystemen voor gebruikte elektrische en elektronische apparatuur, batterijen en accu's.

Wilt u deze op de juiste manier weggooiden bij uw plaatselijk afvalinzameling-/recyclingcentrum in uw buurt?

Help ons het milieu waarin wij leven in stand te houden!

(Swedish)

FÖR ANVÄNDARE INOM EU

Den symbolmärkning och de återvinningssystem som beskrivs här nedan gäller länder inom EU och gäller inte länder i någon annan del av världen.

Din Panasonic-produkt har konstruerats och tillverkats med delar och material av hög kvalitet, som kan återvinnas och/eller återanvändas.

Symbolmärkningen innebär att elektrisk och elektronisk utrustning, batterier och ackumulatorer, vid slutet av deras livslängd, inte får slängas som hushållsavfall utan skall slängas separat.

Observera:

Om en kemisk symbol finns tryckt under denna symbolmärkning, betyder denna kemiska symbol att batteriet eller ackumulatören innehåller en tungmetall med en viss koncentration. Detta indikeras på följande sätt: Hg: kvicksilver, Cd: kadmium, Pb: bly

I den Europeiska Unionen finns det separata uppsamlingssystem för använd elektrisk och elektronisk utrustning, batterier och ackumulatorer.

Gör dig av med sådana saker på rätt sätt på den speciella lokala platsen för återsamling/återanvändning.

Hjälp oss att bevara den miljö vi lever i!



DISPOSAL OF BATTERY

This unit is provided a nickel-metal-hydride battery for the power failure warning device. The battery is located in the electrical box. (Fig. 1)



The high voltage components are enclosed in the electrical box. The cover should be removed by a qualified engineer or a service personnel only to prevent the electric shock.

Disposal of nickel-metal-hydride battery

1. Turn off the power switch and disconnect the power supply plug.
2. Remove six screws fixing the top cover with a screw driver and remove the top cover. (Fig. 1)
3. Remove two screws fixing the battery mounting plate (Fig. 2) and disconnect the battery connector (Fig. 3).
4. Take out the battery. (Fig.4)
5. Follow the procedure for recycling or proper disposal.

Handling of battery

Cover the battery terminal with an insulating tape to avoid the short circuit. Then follow the procedure for recycling or proper disposal.

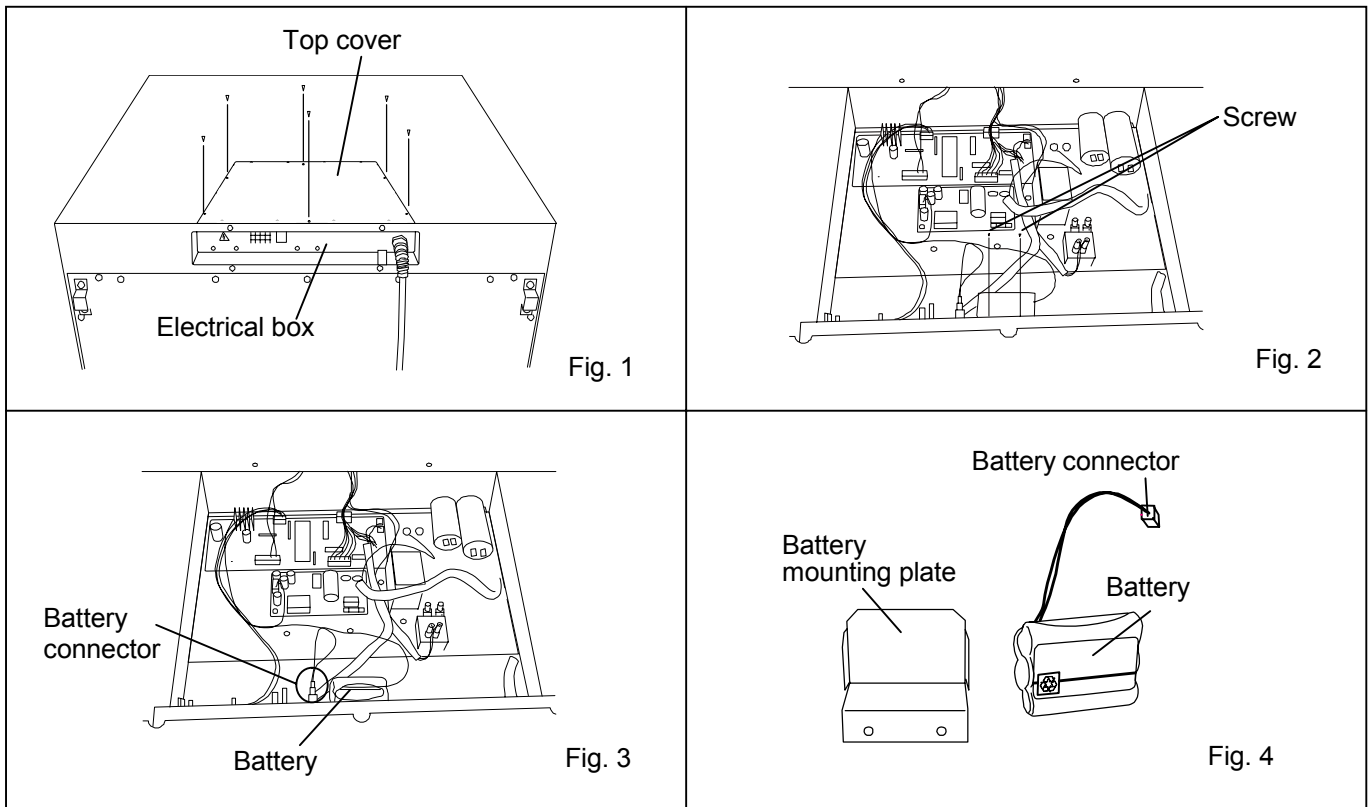

TEMPERATURE RECORDER (OPTION)

Installation of temperature recorder

WARNING

Always disconnect the power supply to the unit prior to attachment of a temperature recorder in order to prevent electric shock or injury.

A temperature recorder is available for the biomedical freezer as the optional component. The type of the temperature recorder is MTR-G85A, MTR-G85C and MTR-4015LH. For the attachment, the recorder fixing is necessary.

Following shows the combination of recorder with the recorder fixing:

Temperature recorder	Recorder fixing
MTR-4015LH (folding chart type)	----
MTR-G85A or MTR-G85C (circular chart type)	MDF-S740T

- Contact our sales representative or agent for the installation of a temperature recorder.

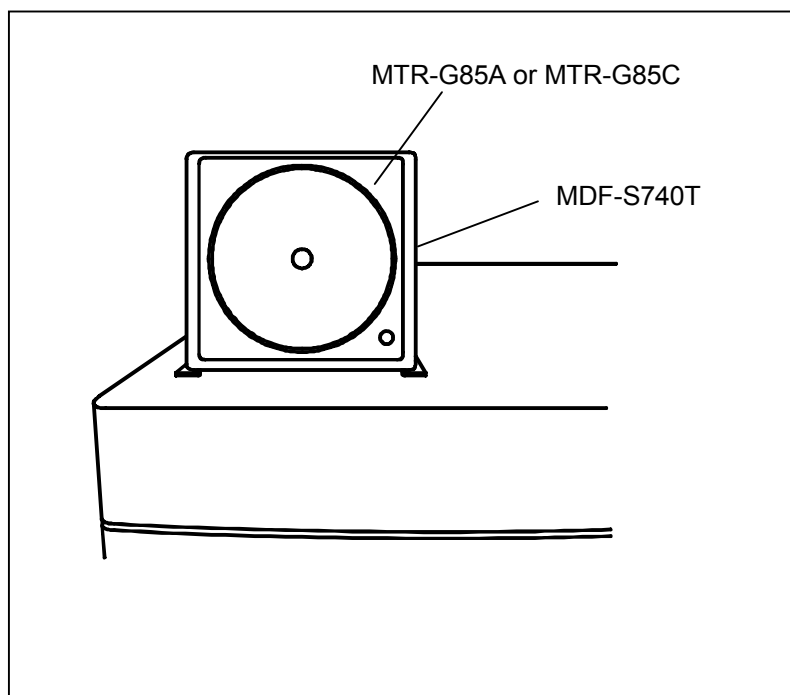

TEMPERATURE RECORDER (OPTION)

Setting of MTR-4015LH

Pull the knob on the upper part of the temperature recorder forward to change the recording paper or battery.

Setting of recording paper

1. The information on the temperature recording paper is shown in Fig. 1.

2. Pull the cartridge up after opening the top lid. The lid can be opened by turning the knob counterclockwise. See Fig. 2.

3. As shown in Fig. 3, insert the recording paper with the "begin" tab placed in the cartridge. Check that the printed side is facing out.

4. Place the recording paper beneath the arm and between the plate spring and guide plate in the direction of the arrow.

Note:

- Do not scratch or put pressure on the recording paper.
- Do not bend the recording paper.
- Do not reverse the recording paper manually.

The used chart paper left in the used chart compartment can cause a malfunction. Be sure to remove it. See Fig. 4.

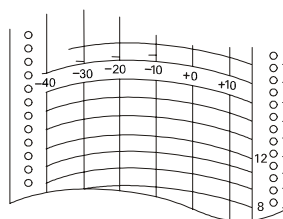

Fig. 1

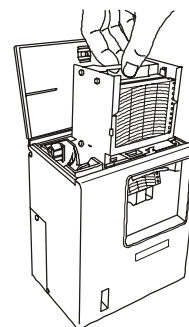

Fig. 2

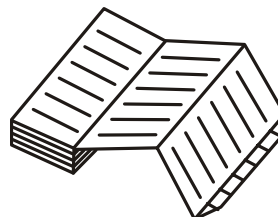

Fig. 3

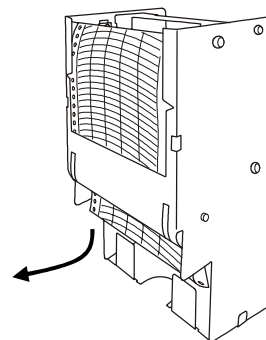

Fig. 4

TEMPERATURE RECORDER (OPTION)

5. Place the recording paper between the guide and the guide plate. Slide the recording paper along the guide plate so that the recording paper will not be forced out of the date/hour slot. See Fig. 5.

6. After ascertaining that the holes on the side of the recording paper are locked into the teeth of the sprocket, turn the gear and send the recording paper into the used chart compartment.

Setting of time

1. Turn the gear on the date/hour slot to the desired time.
2. After properly folding the recording paper in the used or unused recording paper compartment, replace the cartridge.

Removing of the used recording paper

After recording, take out the cartridge and remove the recording paper from the recording paper outlet. If not all of the recording paper has been fed into the used recording paper compartment, send all the recording paper in the compartment first turning the gear.

Battery replacement

To replace the battery, turn the knob counterclockwise to open the lid. Place the battery in the battery case according to the plus-minus indications on the bottom of the battery case. See Fig. 6.

Note :

This temperature recorder is designed for the manganese dry cell and the alkaline dry cell.

Do not use a rechargeable battery because the initial voltage of such battery is low. The rechargeable battery may cause the malfunction of temperature recorder or shorten the battery life significantly.

Start-up

1. The quartz motor is started by placing a "R14" or size "C" dry cell battery in the battery case.
2. Check the operation of the temperature recorder using the quartz motor rotation check gear.
3. Replace the battery once a year.

Stopping

The temperature recorder is stopped by taking the battery out of the battery case.

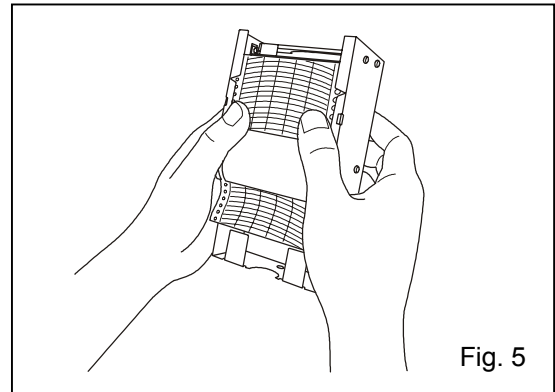

Fig. 5

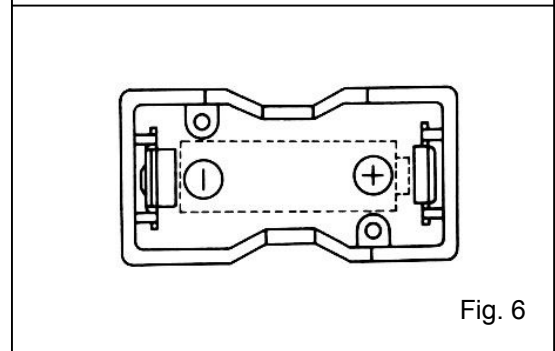
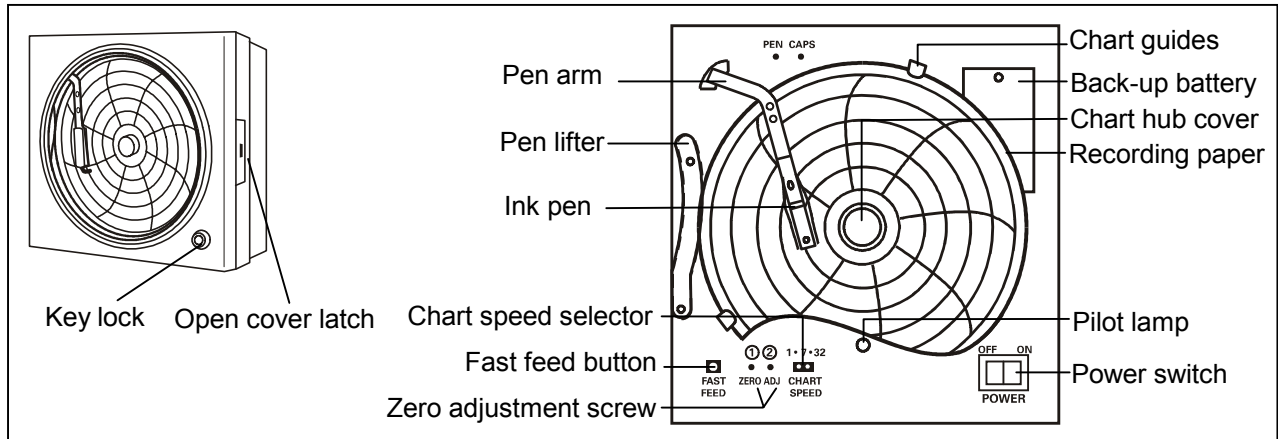

Fig. 6

TEMPERATURE RECORDER (OPTION)

Setting of MTR-G85A or MTR-G85C

Pull the knob on the upper part of the temperature recorder forward to change the recording paper.



Loading the ink pen:

1. Slightly raise the end of the pen lifter and remove from the lifter stopper. Then rotate clockwise as shown in Fig. 1.

2. Remove the ink pen from the bag and remove its cap. The cap can be conveniently kept on the cap holder located at the upper left corner.

NOTE: Loading a pen, turn the power OFF and then ON again to return to the normal mode. (Refer to Fig. 2 when loading a ink pen.

3. Press both sides of the pen arm as indicated by the arrows to open the head clamp at A and B. (See to Fig. 2 illustration 1)

4. Position the ink pen so that the guide pins fit into the guide holes on the pen arm. (See to Fig. 2 illustration 2)

5. Press the two sides of the head clamp as indicated by the arrows to secure the ink pen. (See to Fig. 2 illustration 3) From the side view, the cartridge should fit perfectly on the arm. Confirm that the pen arm is attached to both sides of the ink pen.

6. After loading the ink pen, return the pen lifter to the original position. Confirm that the pen lifter has securely entered the pen lifter stopper.

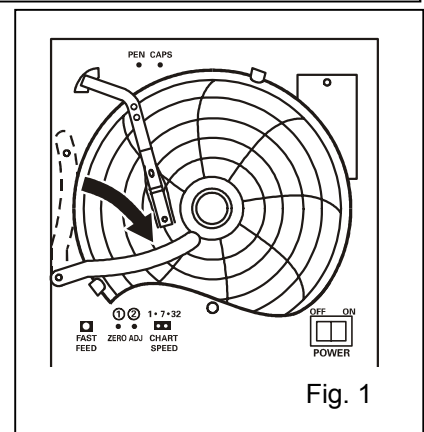

Fig. 1

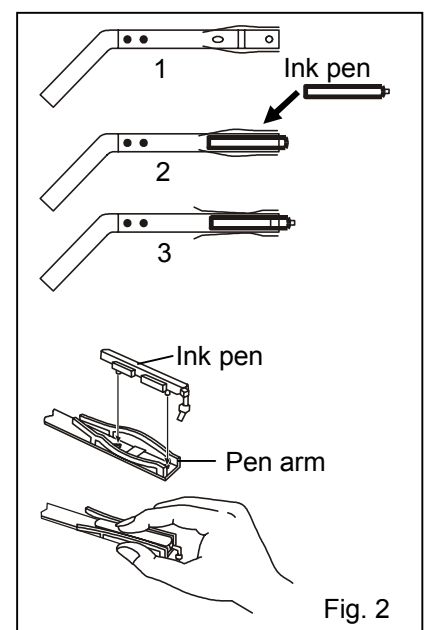

Fig. 2

TEMPERATURE RECORDER (OPTION)

Starting recording and setting the time:

Turn the power switch ON. The pen will move inward on the circular recording paper and stop temporarily at the 0% position (equivalent to the 40°C line). Then the pen will move to the position which indicates the measured temperature. (Fig. 3)

Time setting Method:

Place the recording paper at a position slightly in front of the desired time (the chart is rotated to the left). Set the time by using the fast feed button to quickly rotate the chart. The fast feed button can be used to accurately set the time.

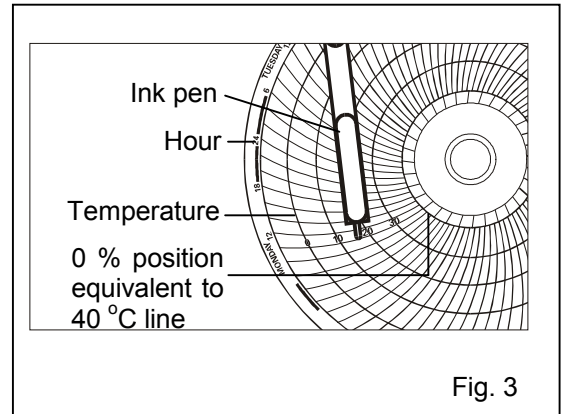

Fig. 3

When the recording paper speed is set to thirty two days:

The center of the recording paper is divided into thirty two equal sections. The lines extending from these lines serve as the thirty two day time scale. (Fig. 4)

Stopping recording:

1. Turn OFF the power switch.
2. When recording is stopped for a prescribed period, place the caps back on the ink pen to prevent the ink from evaporating.

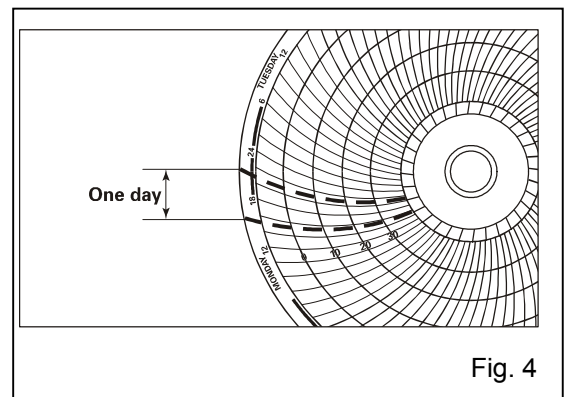

Fig. 4

Replacing the recording paper:

1. Slightly raise the end of the ink pen lifter and remove from the ink pen lifter stopper. Rotate the tip of the ink pen clockwise until it rests on top of the ink pen lifter.
2. Remove the chart hub cover, and then replace the recording paper.
3. Place the chart hub cover. Remove and dispose of the piece of recorder paper. Confirm that the new recorder paper is inside of the chart guides.
4. Set the correct time.

SPECIFICATIONS

Product name	Biomedical Freezer MDF-U334
External dimensions	W614 mm x D709 mm x H1620 mm
Internal dimensions	W490 mm x D486 mm x H1290 mm
Effective capacity	274 L
Exterior	Painted steel
Interior	Styrol resin
Insulation	Rigid polyurethane foamed-in place
Outer door	Painted steel
Lock	1
Caster	4
Leveling foot	2
Evaporator	Tube on sheet type (also used as a shelf)
Access port	Diameter 30 mm 1 on left side
Condenser	Wire and tube type
Compressor	Hermetic type, 200 W
Refrigerant	R-134a
Temperature controller	Electronics controller (between -18°C and -35°C)
Temperature display	Digital display (between -50°C and +50°C)
Temperature sensor	Thermistor sensor
Temperature alarm	Flash of digital indicator and alarm lamp, Buzzer, (Remote alarm)
Accessories	1 set of key, 1 scraper, 4 card holders, 4 large baskets W446 mm x D369 mm x H220 mm 1 small basket W487 mm x D221 mm x H155 mm
Weight	81 kg
Battery	Nickel hydrogen battery, DC 6 V, 1100 mAh (5HR-AAC), Automatic charge
Optional component	Temperature recorder (MTR-4015LH) Temperature recorder (MTR-G85A, MTR-G85C) Recorder fixing for MTR-G85A, MTR-G85C (MDF-S740T) Interface board (MTR-480, MTR-L03) Data acquisition system (MTR-5000)

Note:

- Design or specifications will be subject to change without notice.
- Refer to the updated catalog when ordering an optional component.

PERFORMANCE

Product name	Biomedical Freezer MDF-U334				
Model number.	MDF-U334-PT	MDF-U334-PA	MDF-U334-PB	MDF-U334-PK	MDF-U334-PE
Cooling performance	-30°C (ambient temperature; 35°C, no load)				
Temperature control range	-20°C to -30°C				
Rated voltage	AC 110 V	AC 115 V	AC 220 V	AC 220 V	AC 220 V/ 230 V/240 V
Rated frequency	60 Hz	60 Hz	50 Hz	60 Hz	50 Hz
Rated power consumption	135 W	140 W	130 W	145 W	130 W/ 135 W/140 W
Noise level	35 dB [A] (background noise; 20 dB)				
Maximum pressure	1360 kPa				

Note :The unit with CE mark complies with EC directives.

CAUTION

**Please fill in this form before servicing.
Hand over this form to the service engineer to keep for his and your safety.**

Safety check sheet

1. Freezer contents : Yes No
Risk of infection: Yes No
Risk of toxicity: Yes No
Risk from radioactive sources: Yes No

(List all potentially hazardous materials that have been stored in this unit.)

Notes :

2. Contamination of the unit

- Unit interior Yes No
No contamination Yes No
Decontaminated Yes No
Contaminated Yes No
Others:

3. Instructions for safe repair/maintenance of the unit

- a) The unit is safe to work on Yes No
b) There is some danger (see below) Yes No

Procedure to be adhered to in order to reduce safety risk indicated in b) below.

Date :

Signature :

Address, Division :

Telephone :

Product name : Biomedical Freezer	Model : MDF-	Serial number :	Date of Installation :
--------------------------------------	-----------------	-----------------	------------------------

Please decontaminate the unit yourself before calling the service engineer.

Panasonic Healthcare Co., Ltd.

1-1-1, Sakata Oizumi-Machi Ora-Gun, Gunma 370-0596, Japan

© Panasonic Healthcare Co., Ltd. 2012

Printed in Japan
7FB6P151619001
S0412-10412