

wego™

heart rate monitor

ENDURO₁₀₀

USER MANUAL

measure your **heart rate**
for a better, healthier you!



JoinWeGo.com

CONTENTS

Welcome to WeGo™	1	Regulatory & Safety Notices	8-9
Key Functions	2	Care & Maintenance	10
Watch Reset	2	Trouble Shooting	11
General Operations	3-7	Warranty	12-13
All Modes	3	The WeGo™ Line of Products	14
Time Mode	3		
How to Wear	4		
Pulse Mode	5		
Pulse Setting Mode	6		
Chrono Mode	7		

WELCOME TO WEGO™

WeGo™ allows users to **SEAMLESSLY TRACK** their fitness progress and goals. Our line of activity trackers and heart rate monitors are engineered for **QUALITY** and **VALUE**, using the **LATEST TECHNOLOGY** in data tracking. WeGo's line includes products for all individuals—regardless of their fitness level or activity type.



BE HEALTHIER

prevent injury
and overtraining



BE SMARTER

achieve the most
effective workout



BE HAPPIER

improve personal
fitness levels

KEY FUNCTIONS

This is a 5.3 KHz HRM watch Men's version. Features include HRM functionality that can display your heart rate while you are exercising. 12H or 24H display format can also be selected. There is also an EL back light for 2 to 3 seconds after pressing the S4 button.

Push button main function



S1 – Start/Split

S2 – Stop

S3 – Mode

S4 – EL backlight

2-3 min auto exit if no
key operation

WATCH RESET:

WARNING: All settings will be reset to default values

Reset the watch by pressing and holding S1, S2, S3, and S4 together. All segments will display plus EL on, followed by a beep sound. The watch will then perform a self diagnostic test. The software code will also be displayed.

This watch is water resistant up to 5 ATM.

Battery Type: CR2032

GENERAL OPERATIONS

ALL MODES

The watch has 3 main modes.

Press S3 to scroll through all the modes. The modes are TIME, Pulse, and Chronograph.

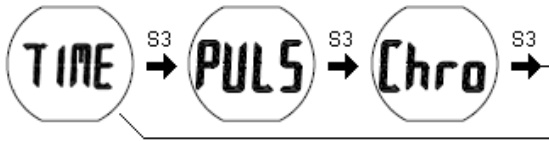

TIME MODE

How to enter TIME mode and view the Day and Date:

In Time mode, press S1 to view the Day, Month and Date.



TIME SETTING MODE

How to set the TIME:

- Press and hold S2 while in Time screen. The hour digit will start to blink.
- Press S1 to change the value of the blinking digit.
- Press S3 to go to the next setting screen.
- Press S2 to exit setting.

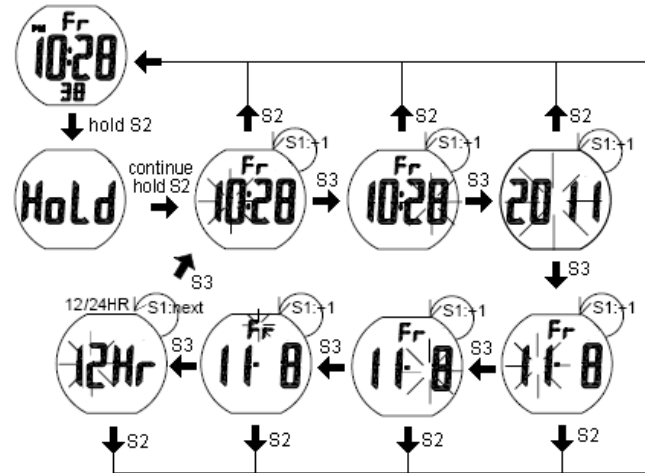

If there is no push button operation for 2-3 minutes, the watch will auto return to Time mode.

GENERAL OPERATIONS

HOW TO WEAR YOUR HEART RATE BELT MONITOR:

The HRM belt is on standby and ready to send data to your watch. Wear the belt directly on your skin just below your breastplate. It should be snug enough to stay in place during your run.

- Push one tab on the strap through the slot in the HRM transmitter.
- Wet both electrodes with a damp cloth on the back of the HRM belt. This will help create a strong electrical connection between your chest and the HRM transmitter.
- Wrap the chest belt around your rib cage just below the pectoral muscles and attach the other end of the strap to the HRM transmitter. The elastic strap should be adjusted so that it is snug enough so that it will not move during use but not so tight as to restrict breathing.
- The HRM belt is now ready to transmit data to the watch.

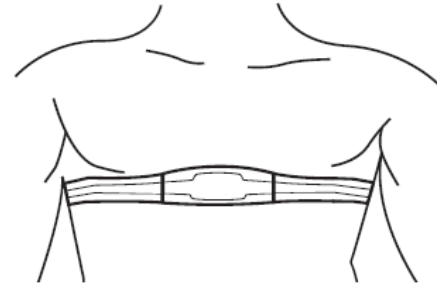
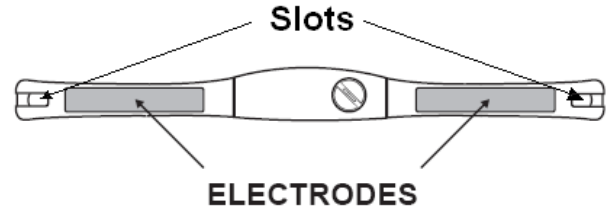

GENERAL OPERATIONS

PULSE MODE

How to enter PULSE mode

- Press S3 from Time mode to go to Pulse mode.
- The watch will automatically search for HRM signal upon entering the PULSE mode.
- Once signal is received, your heart rate will be displayed on the screen. If signal is not received, after 1 minute of searching, it will display “- - -”.
- Press S1 to re-link.

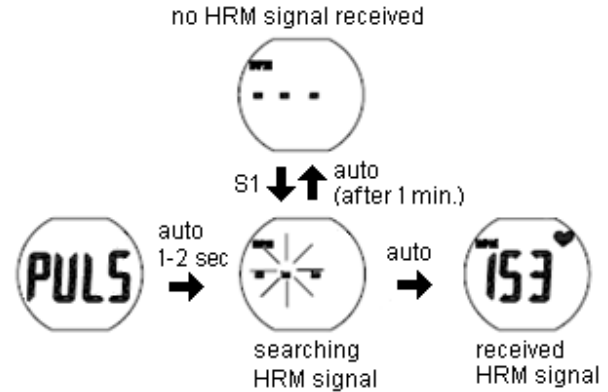

GENERAL OPERATIONS

PULSE SETTING MODE

- Press and hold S2 to set. The HR digit will start to blink.
- Press S1 to increase the value of the blinking digit.
Press and hold S1 to fast increase.
- Press S3 to go to next setting screen.
- Press S2 to exit setting.
- If Zone Alarm (SND) is ON, a beep sound will be given every second when heart rate is below the LO (Low) limit. And 2 beep sounds if the heart rate is above the HI (High) limit. Up or down arrow will also be displayed respectively.
- If Zone Alarm (SND) is OFF there will be no beep sound or Up or Down arrow indicator.
- High and Low limit can be set between 40 to 240 BPM.
- If there is no button operation in setting mode after 2-3 minutes, the watch will auto return to PULSE mode.

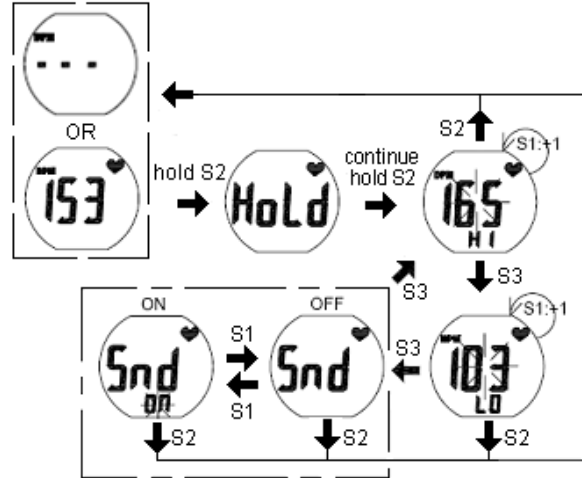

GENERAL OPERATIONS

CHRONO MODE

How to enter CHRONO mode, Start, Take Split, Stop and Reset

- Press S3 from Pulse mode to go to Chronograph mode.
- Press S1 to start, re-start or split.
- Press S2 to stop.
- Press S2 again to reset.
- The chronograph will show 1/100 seconds resolution for the first hour and 1 second resolution for the succeeding hours.
- If Zone Alarm (SND) is ON, there's a beep sound when the heart rate is below the LO (Low) limit and if the heart rate is above the HI (High) limit.
- If Zone Alarm (SND) is OFF there will be no beep sound.

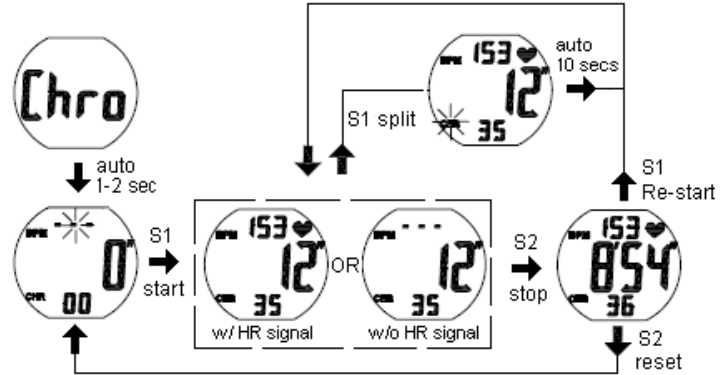

REGULATORY & SAFETY NOTICES

WARNING: Heart rate monitoring systems maybe inaccurate. Over exercising may result in serious injury or death. If you feel faint stop exercising immediately.

This is not a medical device. Should not be used to diagnose or treat any medical condition. Consult your doctor for prevention, diagnosis and treatment. See the user guide for further guidance.

This is not a toy. Keep away from children.

BATTERY SAFETY INFORMATION

- Do not allow children to play with button cell batteries, and keep button cell batteries out of your child's reach.
- Never put button cell batteries in your mouth for any reason as they are easily swallowed accidentally.
- If a button cell battery is ingested, immediately seek medical attention.
- Non-rechargeable batteries are not to be recharged

- Rechargeable batteries must be removed before recharging
- Rechargeable batteries should only be recharged under adult supervision
- Exhausted batteries are to be removed
- Do not mix old and new batteries
- If this product will not be used for an extended period of time, remove the batteries from the product
- The supply terminals are not to be short-circuited
- Batteries are to be inserted with correct polarity
- Clean the battery contacts and also those of the product prior to battery installation
- As always, dispose of batteries in an eco-friendly manner

IMPORTANT

**Do not press the Button under water.
Do not wear product while diving.**

REGULATORY & SAFETY NOTICES



The WEEE symbol on the product or on its packaging indicates that the product must not be disposed of with normal household waste. Instead such marked waste equipment must be disposed of by arranging to return to a designated collection point for the recycling of waste electrical and electronic equipment. By separating and recycling this waste equipment at the time of disposal will help to conserve natural resources and ensure that the equipment is recycled in a manner that protects human health and the environment.

Keep this manual and packaging for future reference since it contains important information

CARE & MAINTENANCE

- NEVER attempt to disassemble or service your unit.
- DO NOT expose the unit to extreme heat, shocks, magnetic fields, electrical noise, strong vibration or long-term exposure to direct sunlight.
- DO NOT drop or step on the watch.
- TO CLEAN THE UNIT: wipe with a lightly moistened cloth. Apply mild soap to the area if there are stubborn stains or marks. Do not expose the unit to strong chemicals such as gasoline, cleaning solvents, acetone, alcohol or insect repellents, as they may damage the unit's seal, case and/or finish.
- STORE the unit in a dry place when you are not using it.

BATTERY REPLACEMENT

Battery replacement will be required from time to time, and should occur when:

1. The display fades in part or completely
2. The heart rate function will not activate
3. Backlight System does not operate
4. The battery icon is visible

To replace the battery of your WeGo™ Heart Rate Watch, we recommend you take it to a watch repair service center or certified jeweler. This will ensure that the water resistance will be retained after battery replacement.

TROUBLE SHOOTING

POTENTIAL CAUSES FOR NO HEART RATE READING OR LONG RESPONSE TIME

CAUSE: Dry skin

SOLUTION: Apply conductive gel thoroughly to chest area (for Chest-Strap measurement) or finger (for Finger-Touch measurement). Tap water may help if conductive gel is not available.

CAUSE: Chest strap is not contacting with skin

SOLUTION: Make sure the chest strap is firmly over the chest and the Watch is securely on wrist.

CAUSE: Muscle tremors caused by pressing on sensors too hard (finger touch)

SOLUTION: Decrease finger pressure on the Sensor Pads.

CAUSE: dead skin on wrist, finger or chest.

SOLUTION: Rub off excessive dead skin with a towel.

CAUSE: a thin layer of body grease insulates the ECG signal preventing the chest strap or watch from detecting ECG heart rate

SOLUTION: Wipe chest/wrist and the back of Chest Strap/watch with a tissue or soft towel.

CAUSE: Hairy skin

SOLUTION: Apply conductive gel to chest area or wrist.

CAUSE: Low battery

SOLUTION: Replace the battery in watch/transmitter and try again.

CAUSE: Electrical field interference from RF devices (chest-strap measurement) such as Overhead power lines, etc.

SOLUTION: Leave the area where RF source potentially exist.

WARRANTY

GUARANTEE CERTIFICATE – FOR PURCHASES MADE IN THE U.S.

If at any time within one (1) year from the purchase date of this product, it fails to perform properly because of defects in material or manufacturing, return it prepaid to: **EB SPORT GROUP, 585 OAK RIDGE ROAD, HAZLETON, PA 18202**

Complete this Guarantee Certificate and enclose it (or a copy of it) with the product. Please contact Customer Service at 866-694-4575 or CustomerService@JoinWeGo.com for a return authorization number, prior to sending in your product.

(PLEASE PRINT CLEARLY)

Name:

Phone:

Address:

Store Purchased From:

Date of Purchase:

Purchase Price:

State:

Zip:

Problem With Product:

WARRANTY

REPLACEMENT

This product has been carefully designed, manufactured and packaged. If any parts are missing or damaged, please contact us at the address above and we will replace the unit at no charge. (Guarantee does not cover crystal or battery.)

FOR PURCHASES MADE IN THE UK

Should you experience problems with this item, please return it to the point of purchase. This will not affect your statutory rights. Alternatively return it to the address shown below for a repair/replacement.

EB Brands UK, Berkeley Business Park, Wainwright Road, Worcester WR4 9FA

www.JoinWeGo.com

Distributed in the UK by EB Brands UK, Worcester WR4 9FA

THE WEGO™ LINE OF PRODUCTS

ACTIVITY TRACKERS



ELITE+

- Sleep Quality
- Goal Setting
- User Replaceable Battery
- Sync Wirelessly



HYBRID+

- Sleep Quality
- Goal Setting
- Sync Wirelessly
- Water Resistant
- Replaceable Straps
- Silent Alarm Vibration



RELAY

- Caller ID/Text Notification
- Auto Sleep
- Sleep Quality
- Sync Wirelessly
- Water Resistant
- Replaceable Straps
- Silent Alarm Vibration

HEART RATE MONITORS



CARDIO/ENDURO 100

- 5.3k Chest Strap
- Time, Chronograph, Heart Rate
- BPM, HR Zone/Alarm
- Date, Lap/Split Time
- Water Resistant 50M



ENDURO 200

- 5.3k Chest Strap
- Time, Alarm, HR, Data Record
- HR Zone/Alarm, Avg/Max HR, BMI
- Run/Lap Memory, Calorie Burn, Recovery HR Monitor/Timer
- Dual Time Zone, Daily Alarms, Lap/Split Time, Night Mode
- Water Resistant 50M



ENDURO 300

- Optical Heart Rate Technology
- Time, Alarm, Chronograph, HR
- HR Zone, % Max HR, Calorie Burn
- Custom User Profile
- USB Rechargeable Battery and Charger Included
- Water Resistant 1ATM



PULSE/PACE

- No Chest Strap Required
- Time, Alarm, Chronograph, HR
- HR Zone/Alarm, BPM and % Max HR Display
- Date, Dual Time Zone, Daily Alarms, Lap/Split Time
- Water Resistant 50M



PULSE/PACE PLUS

- Optical Heart Rate Technology
- Time, Chronograph, HR
- Quick On-Demand HR Reading
- HR Zone, % Max HR
- Custom User Profile
- Water Resistant 1ATM

WeGo™ is the **fitness motivator** that makes it easy to track daily activities. These **easy to use** activity trackers and heart rate monitors can help support a **happy, healthy lifestyle**.

CAUTION: *This is not a medical device. Should not be used to diagnose or treat any medical condition. Consult your doctor for prevention, diagnosis and treatment. See the user guide for further guidance. This is not a toy. Keep away from children.*

CALIFORNIA PROPOSITION 65 WARNING: *This product may contain chemicals known to the State of California to cause cancer, birth defects and/or reproductive harm.*

WARNING: *Heart rate monitoring systems may be inaccurate. Over exercising may result in serious injury or death. If you feel faint stop exercising immediately.*

Made in China. WeGo™ is a trademark of EB Sport Group, Hazleton, PA 18202. Distributed in the United Kingdom by EB Brands (UK), Worcester WR4 9FA. All Rights Reserved ©2015. Designed and engineered by EB Labs.