

EGR-1 Radio-controlled relay module Installation and user manual

TECHNICAL SPECIFICATIONS

Manufacturer:	Sikom AS, Norway
Type/Model:	EGR-1 / 300-8307V10
Power supply:	230VAC 25mA or 12V DC 150mA
Max load on output relay:	16A resistive
Room sensor:	10K NTC at 25°C
Operating temperature:	-20°C to +50°C
Temperature sensing:	-28°C to +49°C ±2°C
Compatible with:	GSM ECO-Starter / EcoStarter Touch series.
Radio frequency:	433.9 MHz
Dimensions (LxHxD):	55x90x59 mm (3 DIN modules)
Weight:	170 g

EGR-1 is designed for indoor use only.

PACKAGE CONTENTS

- EGR-1
- Antenna
- Protection lid

DESCRIPTION

EGR-1 is a fuse box module that offers one relay for switching electric circuits on and off.

EGR-1 offers 3 inputs, of which 2 can be used simultaneously. One input is for a temperature sensor, and the 2 other are for any kind of detector: fire, flooding, gas, burglary (motion detector or magnet contacts).

EGR-1 offers a thermostatic regulation function, which is only available if a temperature sensor is connected to input T1. The user can then enter desired eco/comfort temperatures into the system to obtain a programmable thermostat which can easily be toggled between eco- and comfort temperatures.

OPERATION

EGR-1 is operated either by SMS messages sent to the central unit, or directly from the central unit. For further information please refer to the user manual of the relevant central unit.

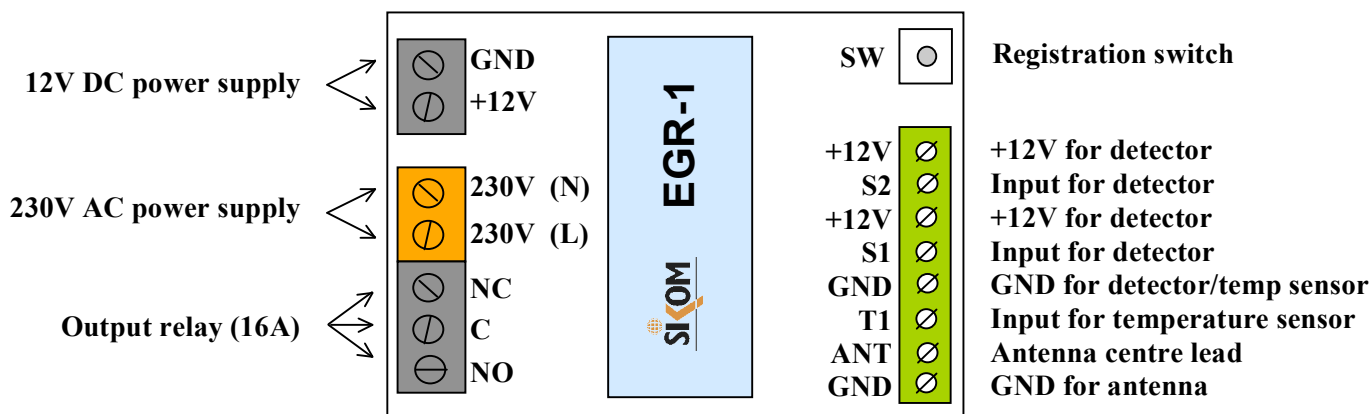

Fig. 1: Connection terminals of EGR-1

INSTALLATION

Power supply:

EGR-1 is to be installed into a fuse box (or other electrically safe place). Use either 230 VAC (orange terminals) or 12 V DC (black terminals) as power supply, **but not both at the same time!** Adjust the protection lid over the 230V terminal strips once all connections are made.

Antenna:

The radio antenna is stripped along 16 cm on one end, which must stick vertically out of the fuse box. Connect the central lead wire to the ANT terminal, and the other one to GND (cf. Fig. 2).

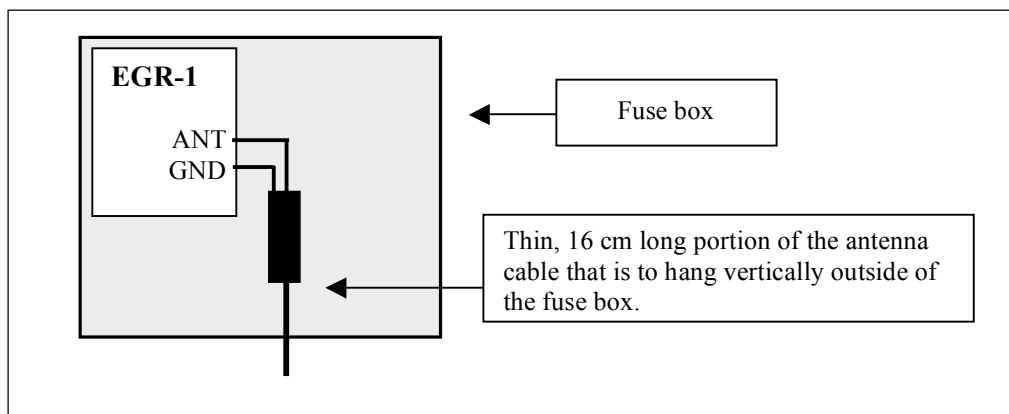

Fig. 2: Installation of antenna

Temperature sensor:

If thermostatic regulation or temperature reading is required, connect a temperature sensor to inputs T1 and GND.

The temperature sensor cable must not be laid out alongside 230V leads and should be kept as far away as possible from any sources of electrical interferences. Thermostatic regulation and temperature reading may otherwise be perturbed. The temperature sensor should therefore not be used as a floor sensor for floor heating installations, as this would require shielded twisted pair sensors and filters. Similarly, whereas it is possible to extend a temperature sensor, it would also induce a loss of precision of measurements.

Output relay:

The potential-free relay is for controlling other appliances; it supports a load of 16 A. It offers thermostatic regulation and on/off control.

NB! When using a 230 VAC power supply, the voltage applied at the relay must also be 230 VAC. Conversely, a power supply of 12V DC limits the use of the relay to extra-low voltages (12V DC or less). Add auxiliary relays or contactors when necessary.

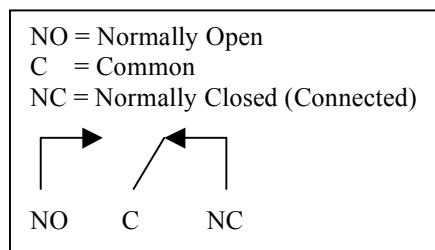

Fig. 3: Relay contacts (in the inactive state)

Detector inputs:

EGR-1 has 3 inputs, but **only 2 inputs may be used at the same time:** either S1 and S2 or T1 and S2. T1 is exclusively for a temperature sensor (if needed). S1 and S2 are inputs for detectors.

Possible combinations:

- Temperature sensor in T1 and detector in S2
- Detector in S1 and detector in S2

Connect the detection loop of the detector to input terminals S1 (or S2) and GND.

A resistor inside each detector tells EGR-1 about the type of the detector. The recognized values are the following:

- 10K = PIR
- 12K = Fire
- 15K = Water
- 18K = Magnet
- 22K = Gas
- 27K = other types
- 33K = generic burglary

Such a resistor is built into all detectors sold by Sikom. For other detectors, mount a suitable resistor in series with the detector, if the detector is of type NC (Normally Connected), and mount the resistor in parallel with the detector, if it is of type NO (Normally Open).

REGISTRATION WITH THE CENTRAL UNIT

1. Go to the setup, then the device registration screen.
If needed, please refer to the registration procedure in the user manual of the central unit.



2. Press then the **SW** button of EGR-1 for at least 5 seconds.
3. On the screen of the central unit, enter the name to be given to the device.
4. The message "Registration OK" will then be shown on the display of the central unit, as well as the 2-digit registration number assigned to this EGR-1 module.
Please write down this number for the end user, as it is required for remote control.

IMPORTANT INFORMATION REGARDING FROST PROTECTION

The thermostatic regulation offered by Sikom devices may be used to maintain a base "eco" temperature in your premises, but **must not be taken as an infallible frost protection**.

Indeed, any electronic equipment is vulnerable to power surges and other perturbations that may come from the electricity network, e.g. due to lightning. In such an event, if the electronics is damaged, it may no longer ensure the thermostatic regulation, and hence the frost protection.

Therefore, if frost protection is a critical requirement (such as around water pipes), it is recommended to add a security mechanism. These are some alternatives:

- Use an additional heating system, with its own thermostat, to ensure frost protection in critical premises.
- Install a protection against power surges and other perturbations from the electricity network.
- Set up a bimetal thermostat in parallel with your Sikom unit.

Sikom and its representatives will not assume liability for any damage due to frost!

COMPLIANCE WITH INTERNATIONAL REGULATIONS

This equipment complies with the European R&TTE directive. Further information may be obtained by contacting either www.EcoStarter.com or the manufacturer:

Sikom AS (www.sikom.no)
Neptunveien 6
7650 Verdal
Norway

WARRANTY

Sikom A.S. products are covered by a two years warranty against any faults due to material flaws or manufacturing errors, which limit or render useless certain functions described for the product. The warranty requires the customer to present the original bill, with date of purchase and type of equipment clearly readable.

What is covered by the warranty?

During the warranty period, Sikom A.S. reserves the right to repair the product or to replace defective parts with functionally equivalent parts. If, after several attempts, Sikom A.S. is unable to correct the problem, and the product does not work as described in the manual, Sikom may elect to refund the purchase price or to replace the product with a functionally equivalent one. All replaced parts and products become the property of Sikom A.S.

What is not covered by the warranty?

- Indirect damage to life, health, property, revenue and environment caused by circuits and appliances connected to the units (install and use this product responsibly).
- Costs related to (re)installing, transporting and dismantling units; recycling may be governed by special rules (see the relevant chapter).
- Damages caused by use outside of the operating conditions specified in the manual.
- Malfunctions caused by transport damages.
- Any unauthorized repair, modification or disassembly.
- Use of non-original parts.
- External factors, such as lightning, power supply issues, mobile network issues, flood damage or fire.
- Units with modified, removed or unreadable serial number.

Sikom assumes no responsibility for any errors that may appear in this manual. Information contained herein is subject to change without notice.

RECYCLING INFORMATION

Waste Electrical and Electronic Equipment (WEEE) Symbol



The WEEE (Waste Electrical and Electronic Equipment) symbol indicates that this product must not be disposed of along with other household waste. It is the customer's responsibility to dispose of the product properly by taking it to a designated site for recycling. To locate a recycling/disposal site near you, contact your local city recycling program, your regular waste disposal service or the agent from whom you purchased this product.

For Switzerland, this product includes in its purchase price a contribution (the advanced recycling fee) to the SWICO Recycling Warranty, which means that used equipment can be handed in free of charge for recycling. Collection sites are listed at <http://www.swicorecycling.ch>