

# User Manual

Version 3.1



## VMT 5015



ads-tec GmbH  
Raiffeisenstr.14  
D-70771 Leinfelden-Echterdingen  
Tel: +49 (0) 711 / 45894-0  
Fax: +49 (0) 711 / 45894-990  
[mailbox@ads-tec.com](mailto:mailbox@ads-tec.com)  
<http://www.ads-tec.com/>

### **Copyright**

© ads-tec GmbH  
Raiffeisenstr.14  
D-70771 Leinfelden-Echterdingen  
Germany

# INDEX

<b>ABOUT US</b> .....	<b>5</b>
<b>1 REMARKS</b> .....	<b>6</b>
1.1 RELEVANT DOCUMENTATION FOR THIS DEVICE.....	6
1.2 USED SYMBOL EXPLANATION .....	6
1.3 DATA, FIGURES AND MODIFICATIONS .....	6
1.4 TRADE MARKS .....	6
1.5 COPYRIGHTS .....	7
1.6 ENVIRONMENTAL CONDITIONS .....	7
1.7 STANDARDS .....	8
1.8 EQUIPMENT VERSIONS.....	8
1.9 SCOPE OF DELIVERY.....	9
<b>2 OPERATING INSTRUCTIONS</b> .....	<b>10</b>
2.1 OPERATING LOCATION.....	10
2.2 DAMAGE CAUSED BY IMPROPER USE.....	10
2.3 WARRANTY / REPAIR.....	11
<b>3 INSTALLATION</b> .....	<b>12</b>
3.1 INSTALLATION OPTIONS .....	12
3.2 EXTERNAL DEVICE DIMENSIONS.....	17
<b>4 COMMISSIONING</b> .....	<b>18</b>
4.1 AVAILABLE INTERFACES .....	18
4.2 CABLE INSTALLATION .....	19
4.3 ORDER OF COMMISSIONING STEPS .....	19
4.4 CHECK OF READINESS FOR OPERATION .....	19
<b>5 OPERATION</b> .....	<b>20</b>
5.1 FRONT CONTROL KEYS.....	20
5.2 SOFT KEYBOARD .....	21
5.3 TOUCHSCREEN .....	22
5.4 STATUS INDICATORS.....	22
<b>6 INTERFACES</b> .....	<b>23</b>
6.1 INTERFACE SETUP .....	23
6.2 SERIAL COM INTERFACE (RS232) .....	23
6.3 USB CONNECTIONS .....	24
6.4 EXTERNAL KEYBOARD .....	25
6.5 MOUSE .....	26

6.6	24V DC POWER SUPPLY .....	27
6.7	NETWORK CONNECTION (RJ45) .....	28
6.8	LINE OUT / SOUND .....	28
6.9	OPTIONAL RADIO NETWORK CARD .....	28
<b>7</b>	<b>DRIVES.....</b>	<b>29</b>
7.1	HARD DRIVES / COMPACT FLASH DRIVES (IDE INTERFACE) .....	29
7.2	EXTERNAL DRIVES.....	29
<b>8</b>	<b>SOFTWARE &amp; DRIVER INSTALLATION.....</b>	<b>30</b>
8.1	INSTALLING THE OPERATING SYSTEM.....	30
8.2	TOUCHSCREEN DRIVER INSTALLATION.....	31
8.3	SOFT KEYBOARD.....	31
<b>9</b>	<b>TECHNICAL DETAILS .....</b>	<b>32</b>
9.1	DISPLAY DATA .....	32
9.2	COMPUTER DATA .....	32
9.3	GENERAL DATA .....	32
<b>10</b>	<b>SERVICE AND SUPPORT.....</b>	<b>33</b>
10.1	ADS-TEC SUPPORT.....	33
10.2	COMPANY ADDRESS .....	33

## ABOUT US

ads-tec GmbH  
Raiffeisenstr. 14

70771 Leinfelden-Echterdingen  
Tel: +49 (0) 711 / 45894-0  
Fax: +49 (0) 711 / 45894-990  
www.ads-tec.com  
Germany



ads-tec GmbH provides large enterprises and globally active corporations with cutting edge technology, up-to-date know-how and comprehensive services in the area of automation technology, data processing technology and systems engineering.



ads-tec GmbH implements full automation solutions from planning to commissioning and is specialized in handling and material handling technologies.



The data systems division develops and produces PC based solutions and offers a broad range of industrial PCs, thin clients and embedded systems.



ads-tec is specialized in modifying and optimizing embedded operating systems and develops software tools to complement its hardware platforms.

# 1 REMARKS

## 1.1 RELEVANT DOCUMENTATION FOR THIS DEVICE

The following documents are essential for setting up and operating this device:

### **USER MANUAL ON SERVICE CD (DOCUMENTATION ON HAND):**

Contains information for installation, commissioning and operating the device along with technical data of the device hardware.

### **SERVICE CD:**

Contains drivers and the user manual.



#### **Note:**

*The "Drivers-xx.pdf" file contains an overview table showing which drivers from the service CD are to be used for which device. You must open the "Which driver for which device" menu item in order to open this file.*

## 1.2 USED SYMBOL EXPLANATION



#### **Warning:**

*The "Warning" symbol refers to activities which might cause personal injury or damage to the hardware or software!*



#### **Note:**

*The "Note" symbol familiarises you with conditions to be observed in order to ensure flawless operation. Additionally, hints and advice are given for a more efficient use of the device and for software optimisation.*

## 1.3 DATA, FIGURES AND MODIFICATIONS

All texts, data and figures are non-binding. We reserve the right of modification in accordance with technological progress. At that point in time when the products leave our premises, they comply with all currently applicable legal requirements and regulations. The operator/operating company is independently responsible for compliance with and observance of any subsequently introduced technical innovations and new legal requirements, as well as for all usual obligations of the operator/operating company.

## 1.4 TRADE MARKS

We would like to remind you that all software and hardware designations as well as trade names of companies used in this documentation are subject to the general, international trade mark, brand or patent protection laws.

WINDOWS<sup>®</sup>, WINDOWS<sup>®</sup> CE and WINDOWS<sup>®</sup> CE.net<sup>™</sup> are trade marks registered by Microsoft Corp.

Citrix<sup>®</sup> and ICA<sup>®</sup> are trade marks registered by Citrix Systems Inc.

Intel<sup>®</sup> and Pentium<sup>®</sup> are trade marks registered by Intel Corp.

IBM<sup>®</sup>, PS/2<sup>®</sup> and VGA<sup>®</sup> are trade marks registered by IBM Corp.

CompactFlash™ and CF™ are trademarks of SanDisk Corp.

All other nationally and internationally recognised trade marks and product names are hereby likewise recognised.

## 1.5 COPYRIGHTS

This manual, including all contained figures, is protected by copyright law. Any use for third parties non-compliant with the copyright provisions is prohibited. Any reproduction, translation as well as electronic and photographic archiving and modification shall only be permitted after explicit written authorisation by ads-tec GmbH.

Any party in violation of this provision shall be obliged to damage compensation.

## 1.6 ENVIRONMENTAL CONDITIONS

The device may be operated under the following conditions. Failure to observe these specifications will terminate any warranty for this device. Ads-tec cannot be held liable for any damages arising due to improper use and handling.

- Temperature for devices including a HDD:
 

In operation	0 ... 45° C
For storage	-20 ... 45° C

(Because of the integrated max. temperature memory)
- Temperature for devices including a compact flash memory:
 

In operation	0 ... 45° C
For storage	-20 ... 45° C

(Because of the integrated max. temperature memory)
- Temperature for devices including a heater (only CF-Devices)
 

In operation	-20 ... 45° C
For storage	-20 ... 45° C

(Because of the integrated max. temperature memory)
- Humidity:
 

In operation	10 ... 85% without condensate
For storage	10 ... 85% without condensate
- Vibrations:
 

In operation	1 G, 10 ... 500 Hz
--------------	--------------------

(EN 60068-2-6)
- Shock resistance:
 

In operation	5 G, with a half-wave of 30 ms duration
--------------	---

(EN 60068-2-27)

## 1.7 STANDARDS

This unit is compliant with the provisions and safety objectives of the following EU Directives:

- This unit is compliant with the CE mark testing specification limits as defined in the European test standards EN 61000-6-4 und EN 61000-6-2
- This unit is compliant to the DIN EN 60950 (VDE0805, IEC950) testing specification limits on "Safety of Information Technology Equipment"
- This unit is compliant to the DIN EN 60068-2-6 (sinusoidal vibration) testing specification limits
- This unit is compliant to the DIN EN 60068-2-27 (shock and bump) testing specification limits



**Note:**

*A corresponding declaration of conformity is available for competent authorities, care of the Manufacturer. Said declaration can be viewed at all times upon request.*

*For full compliance to the legal requirements in force on electromagnetic compatibility, all components and cables used for unit connection must also be compliant with said regulations. It is therefore necessary to employ BUS and LAN cables featuring screened plug connectors, to be strictly installed as per the instructions contained in the User Manual.*

## 1.8 EQUIPMENT VERSIONS

The system is available in two equipment versions:

Platform for use with compact flash memories:

Platform without any rotating mass storage media (hard disks, etc.) including embedded operating systems (Windows CE.net / XP embedded) for stationary use in connection with standard Ethernet or radio network cards on portable commissioning and/or forklift equipment.

Platform including hard disks:

Including hard disks for stationary use, e.g. in manufacturing using standard operating systems.



## 1.9 SCOPE OF DELIVERY

Please check that all of the following components are contained in the packaging:

- 1 device
- 3 pin Feed-through connector from Phoenix Contact, COMBICON MC 1.5/3-STF-3.81 type (already connected with the device socket)
- Service CD

### Optional scope of delivery

- Operating system
- Installation kit
- 2.4 GHz WLAN antennas, enclosed for b/g

## 2 OPERATING INSTRUCTIONS

This device contains electrical voltages and extremely sensitive components. The manufacturer, or a service partner authorised by the manufacturer, should be consulted if you plan to make any modifications. For this type of work, the device must be switched off at the mains and the power lead must be disconnected. Suitable measures for avoiding electrostatic discharge towards parts of the components when touching the equipment must be taken. If the device is opened by an unauthorised person, hazards for the user might arise and any warranty claim will cease.

### General instructions:

- All users must read this manual and have access to it at all times.
- Installation, commissioning and operation may only be carried out by trained and qualified staff.
- The security instructions and the manual itself must be observed by all persons who work with this device.
- At the location of use, the valid guidelines and regulations for accident prevention must be observed.
- The manual contains the most important instructions on how to use this device in a safe way.
- Appropriate storage, proper transport, installation and commissioning, as well as careful operation are prerequisites for ensuring safe and proper operation of the device.

**Warning:**

*Any leads (e.g. power leads, interface cables) may only be connected if the device is switched off in order to avoid damaging the device.*

### 2.1 OPERATING LOCATION

The VMT control system is designed for use with support arm systems or on mobile base equipment (commissioning trolleys, fork lift equipment, and similar). You have to take care that the environmental conditions indicated in the technical specification are met. Using the device in non-specified environments, for example on board ship or in areas that might contain explosive gases, or in extreme heights, is prohibited.

**Warning:**

*The device may only be switched on after acclimatising to the ambient temperature in order to avoid condensate accumulation. The same applies if the device has previously been exposed to extreme temperature variations.*

*To avoid overheating in operation: The device must never be exposed to direct radiation by sunlight or any other light or heat source.*

### 2.2 DAMAGE CAUSED BY IMPROPER USE

This device must immediately be shut down and protected from any accidental commissioning if the operating system shows any obvious damage caused by, for example, improper operating or storage conditions, or by improper use or handling.

### **2.3 WARRANTY / REPAIR**

During the warranty period any repair must only be carried out by the manufacturer or by a person authorised by the manufacturer.

## 3 INSTALLATION

### 3.1 INSTALLATION OPTIONS

#### Gallow bracket for Rittal systems

The stainless steel installation bracket for gallow type installations (CP-S/CP-L) has four drill holes. By using this bracket, the device can be fixed on a gallow. You can set the angle of the device towards the front or rear in several steps by loosening the self-locking screws on both sides, in order to set up the angle of viewing.

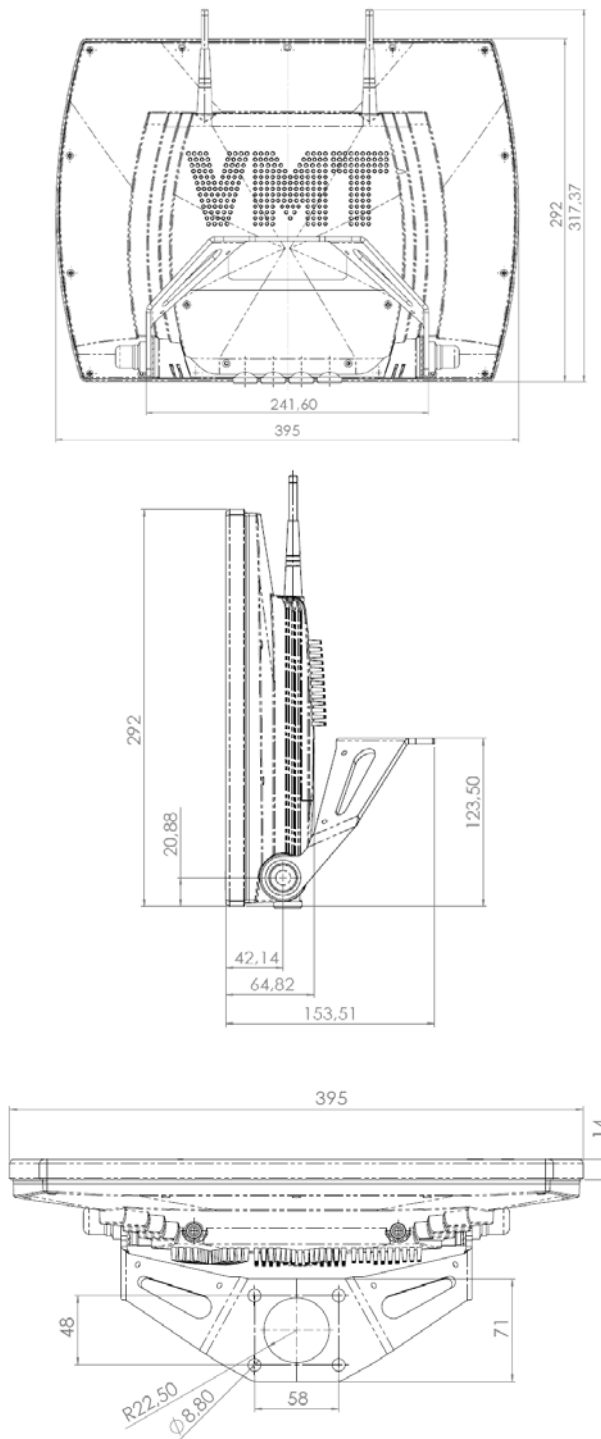

Bracket for VESA standard

The stainless steel installation bracket for the VESA standard (75mm) has four drill holes. Using this bracket, the device can be fitted to a wall or to a VESA coupler. You can set the angle of the device towards the front or rear in several steps by loosening the self-locking screws on both sides, in order to set up the angle of viewing.

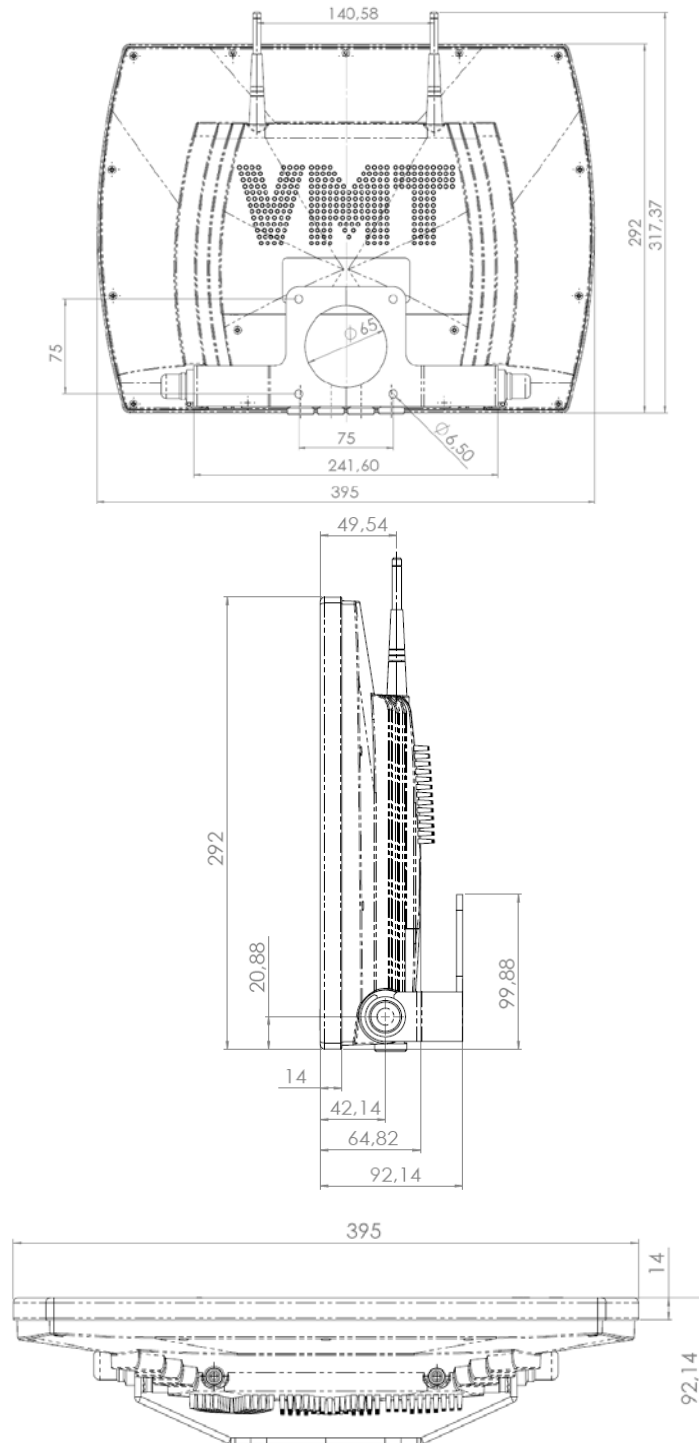

Desktop bracket

The stainless steel bracket for desktop installation has 12 drill holes. By using this bracket, the device can be fixed to a control stand or desktop. You can set the angle of the device towards the front or rear in several steps by loosening the self-locking screws on both sides, in order to set up the angle of viewing.

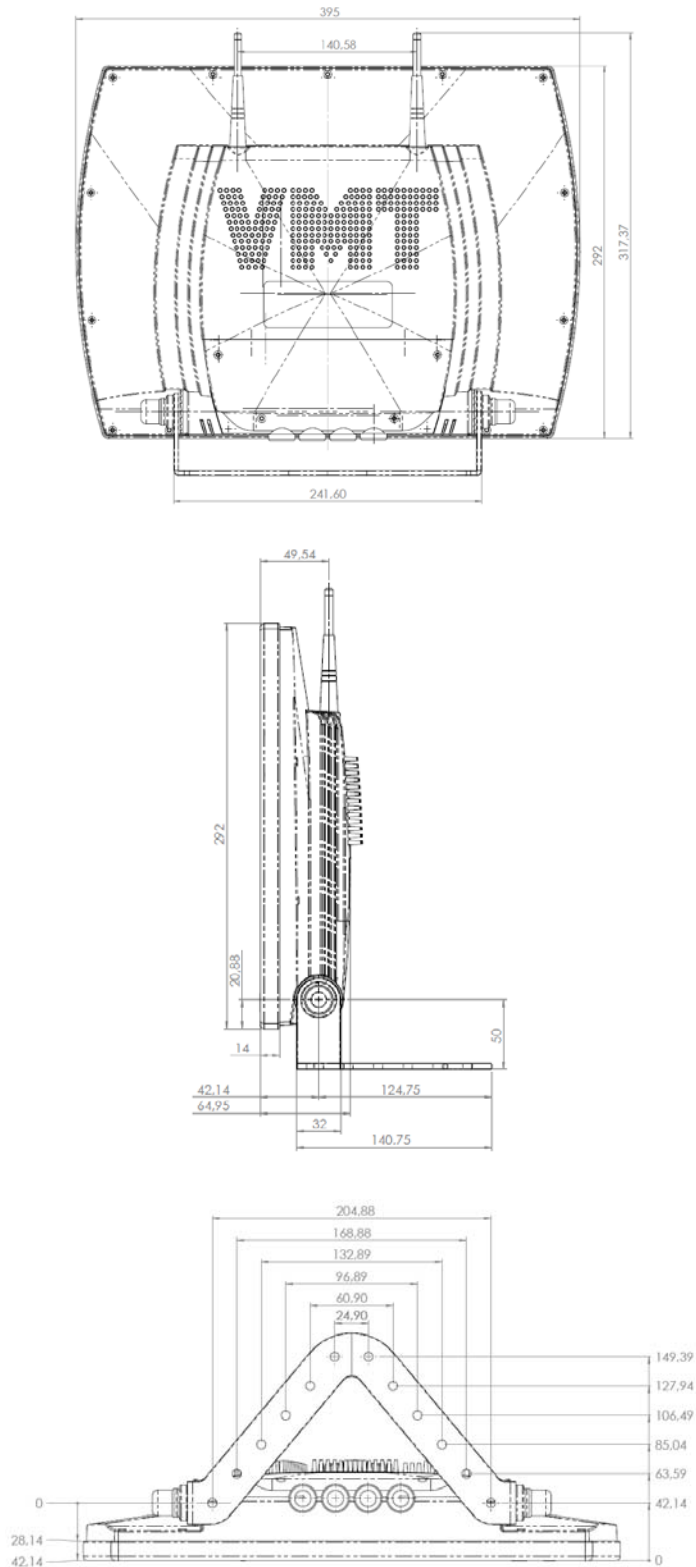

Bracket for 90° installation

The stainless steel bracket for angled installation in a 90° angle allows a flexible use. It has four drill holes for fixing the device. You can set the angle of the device towards the front or rear in several steps by loosening the self-locking screws on both sides, in order to set up the angle of viewing.

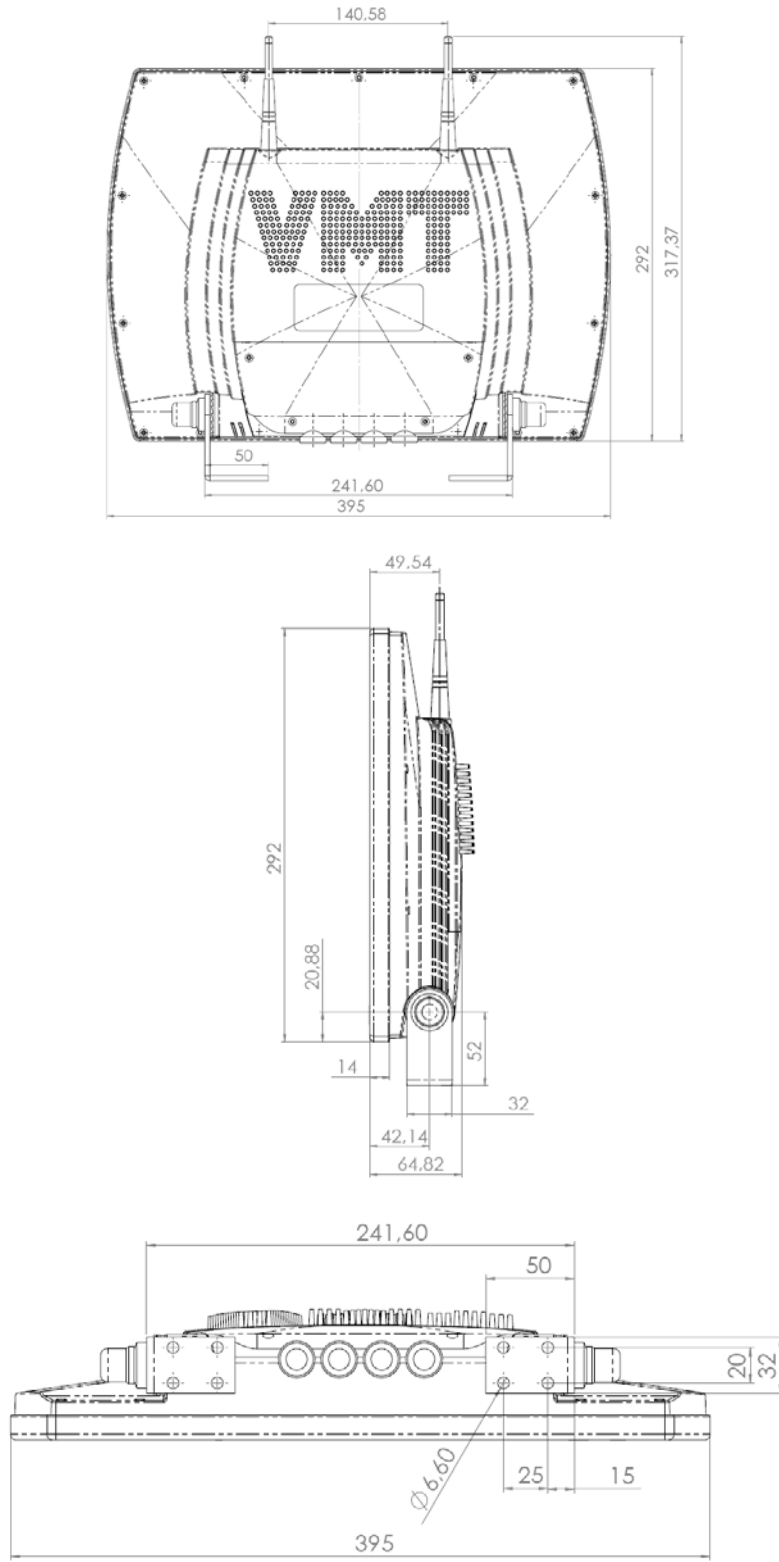

### Customer-specific brackets

For manufacturing of customer specific brackets, you'd have to consider that the bolts on the device side are fixed, and cannot be removed.

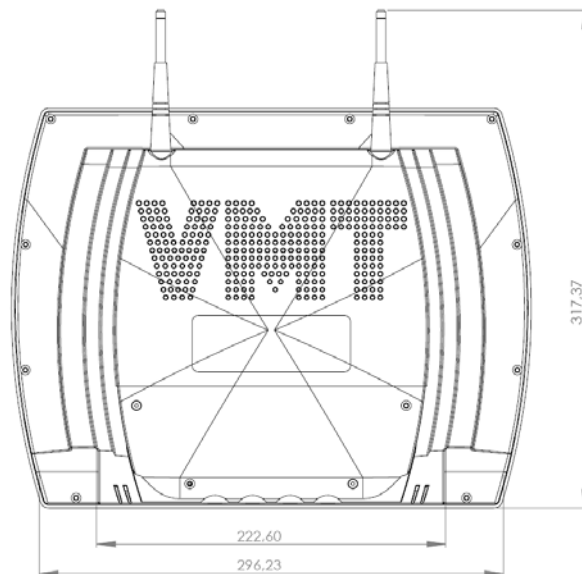
**Note:**

*The figure on this page shows a VMT 5012 device. The VMT fixing points for a customer-specific bracket are the same with all VMT devices.*



### 3.2 EXTERNAL DEVICE DIMENSIONS

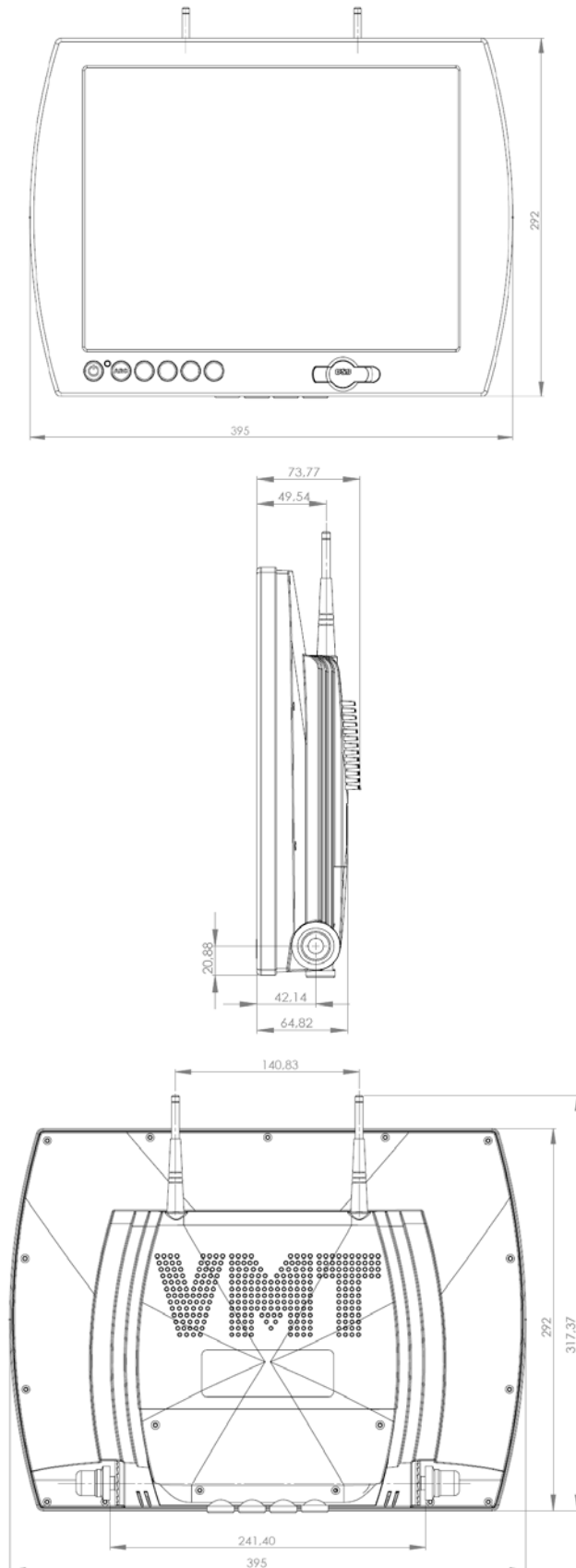

## 4 COMMISSIONING

The power supply connection and interfaces of this device are installed inside the case. You have to remove the case cover in order to connect the power supply cables and the interface cables.

All supply leads and all required data leads have to be connected before commissioning.



### **Warning:**

*The device must be switched off before connecting or disconnecting any cables in order to prevent damage to the electronics!*

*The device may only be switched on after acclimatising to the ambient temperature in order to avoid condensate accumulation. Make sure to meet the admissible voltage requirements for this device.*

*After switching off and before switching on you must wait for at least 5 seconds.*



### **Note:**

*The screen of a data cable must always be connected with the connector housing (EMC).*

*Under the embedded operating system, interfaces must explicitly be enabled and required drivers must be installed in order to be able to use them.*

### 4.1 AVAILABLE INTERFACES

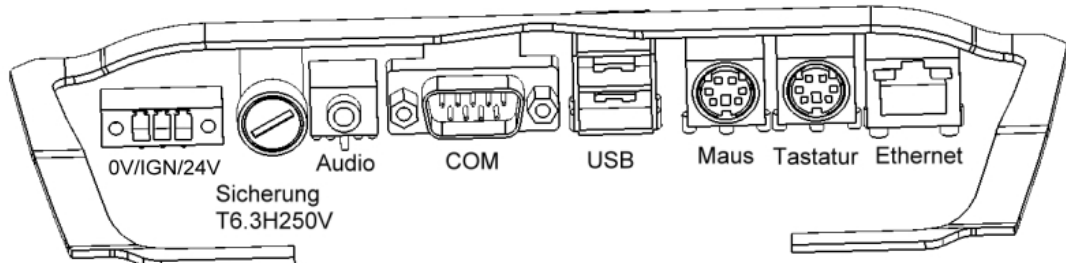

### **Hinweis:**

*The device can be started with the ignition function.*

## 4.2 CABLE INSTALLATION

The power supply connectors and interfaces of this device are installed inside the case. Cables can be routed through rubber grommets and exit the case on the bottom. The grommets are inserted between the case and the cover, and can easily be removed after removing the cover. Since this device includes the required input peripherals (soft keyboard / touch screen), only one grommet for the power supply cable (cable diameter of 6...7mm) as well as three blank plugs are integrated by default. Should it be required to feed through more cables from the device to the outside, these blank plugs must be replaced by suitable grommets (optionally available accessories).

## 4.3 ORDER OF COMMISSIONING STEPS

- Remove the case cover screws and carefully remove the cover.
- Fix the wires of the power supply cable in the screw terminals by using wire end sleeves.
- Plug the data cable connector on the desired interface connector and screw it on, if possible.
- Select a cable grommet with a suitable diameter for each cable to be fed through, and enclose the cable with it.
- Remove the blank plug and replace it with the grommet surrounding the cable.
- Attach the case cover properly and install the screws.

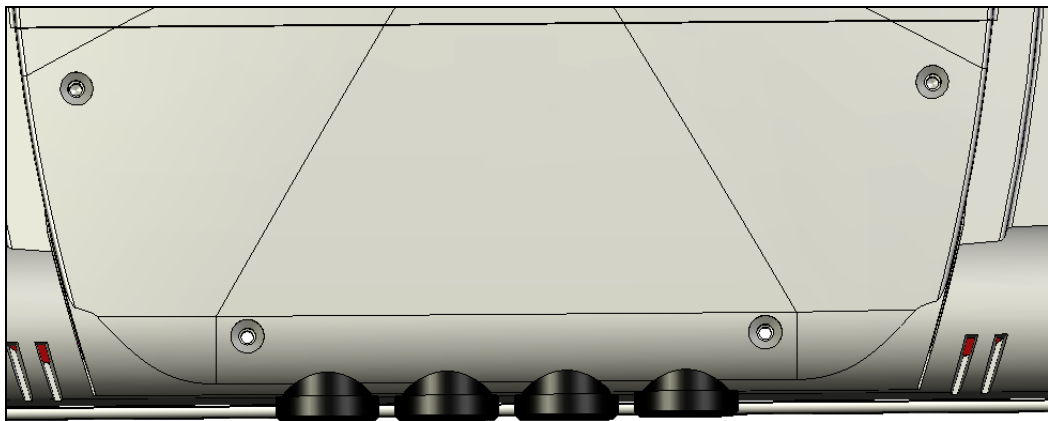

**Note:**

*The service slot is fixed with captive screws.*



**Warning:**

*Full protection according to the indicated protection class is only ensured if the case cover is properly installed!*

## 4.4 CHECK OF READINESS FOR OPERATION

Check the device for any hidden damage caused by improper transport, improper operating or storage conditions or by improper use (e.g. smoke development from the device, etc.). Immediately shut down the device and prevent any further accidental commissioning if any damage is detected.

## 5 OPERATION

### 5.1 FRONT CONTROL KEYS

Depending on the equipment version of the device, an operating system (Windows CE.net, Windows XP embedded or Windows XP Prof.) and a soft keyboard might be already installed ex factory. The following functions are already assigned to the keys on the front panel by a specific driver in the soft keyboard:



On / Off pushbutton for the device (ATX functionality)



Level 1:

Activate and deactivate the soft keyboard for letter/character input using the touchscreen.

Level 2:

Increase the volume with devices using a speaker/audio output.



Level 1:

Change tasks (Alt+ESC) in Windows.

Level 2:

Decrease the volume with devices using a speaker/audio output.



Level 1:

Not connected

Level 2:

Increase display brightness



Level 1:

Right mouse-key function

Level 2:

Decrease display brightness



Shift key (SHIFT) for activating the second keyboard level. This key must be pressed simultaneously with the desired function key.



**Note:**

*If the software keyboard is not installed, only the functions for display settings and volume control are active. The controller display is not output on the display, in this case. The functions assigned to the keys, might already be modified according to customer specifications. Above described functions are pre-set ex works.*

## 5.2 SOFT KEYBOARD

If the operating system is installed ex works, the soft keyboard is included in this installation. If the device is delivered without any operating system, the soft keyboard has to be installed by the customer. By using the soft keyboard, data can be entered via the touchscreen like with an external keyboard.

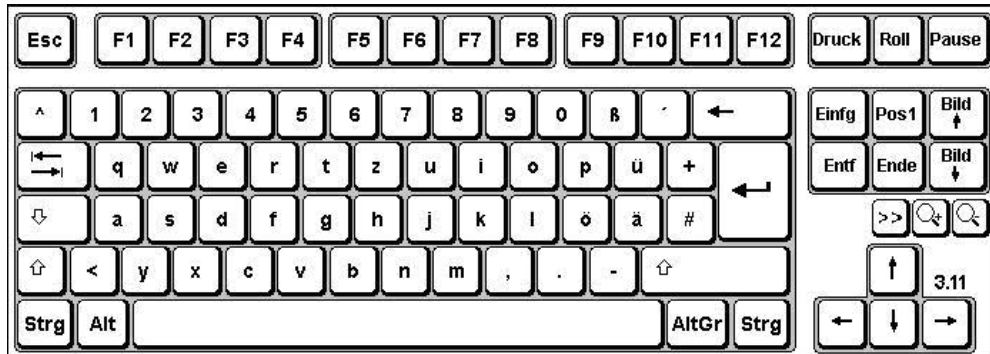

### HOW TO OPERATE THE SOFT KEYBOARD FROM VERSION 3.11:



Activate and deactivate the soft keyboard for letter/character input using the touchscreen

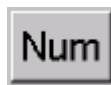

Switches display of numeric keypad on/off (only if numeric keypad is displayed)



Switching between representation modes (alphanumeric keypad → numeric keypad → bar of function keys)



Soft keyboard representation, zoom in



Soft keyboard representation, zoom out



#### Note:

If a function is to be activated, which requires pressing two keys at the same time (e.g. Alt + F4); these keys have to be pushed one after another at the soft keyboard, and the special keys Shift, Alt and Ctrl must always be pushed first.

Due to differences in programming of a large variety of software, we cannot ensure that the soft keyboard works properly with all software.

When deactivating the soft keyboard, the previously active state (alphanumeric / numeric keys or function keys) will be stored and will be displayed when re-activating the keyboard.

### 5.3 TOUCHSCREEN

The control system is equipped with an touchscreen. The touchscreen is internally connected with a serial interface. The driver software required for its use is already integrated in the corresponding operating system, or can be installed from the attached service CD.

### 5.4 STATUS INDICATORS

#### **SYS LED (BICOLOURED)**

Depending on the colour and type of flashing, different device states are displayed by the SYS LED.

The following signals are displayed:

- LED lights green      The device is ready for operation (Power ON).
- LED is off              The device is switched off. (Power OFF)

## 6 INTERFACES

### 6.1 INTERFACE SETUP

INTERFACE	IRQ	ADDRESS
COM1	4	3F8h
COM2 (Touch)	3	2F8h

### 6.2 SERIAL COM INTERFACE (RS232)

The serial interface is used for digital and for analogue data transmission as well. The RS 232 interface can be connected by using a commercially available 9-pin SUB-D cable.

PIN NUMBER	SIGNAL NAME
1	DCD
2	RxD
3	TxD
4	DTR
5	GND
6	DSR
7	RTS
8	CTS
9	RI

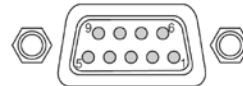

**Note:**

*This interface is not electrically isolated.*

### 6.3 USB CONNECTIONS

The USB interfaces are used for connecting peripherals with USB connection. The interface complies with the USB 2.0 standard.

PIN NUMBER	SIGNAL NAME
1	VDC
2	D -
3	D+
4	GND



**Note:**

*The USB interfaces may be locked using the Lock USB software tool. You'll find this software and the documentation on the service CD.*

#### **USB CONNECTION ON THE FRONT PANEL**

One USB interface can be accessed from the front. This interface is located under a plastic cover beneath the display. The cover has a tab on the right-hand side, which is used for opening. The plastic cover must properly be replaced and carefully closed after using the USB interface, since otherwise the protection class of IP65 is no longer ensured.



## 6.4 EXTERNAL KEYBOARD

One mouse and one keyboard can be connected with both existing PS2 connectors. These connections are colour coded for proper connection with this device.

PIN NUMBER	SIGNAL NAME
1	Data
2	NC
3	GND
4	+5V
5	Clock
6	NC

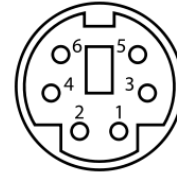

The control system has a purple coloured 6-pin mini-DIN socket (PS2) identified as "KEYB". Any commercially available AT-compatible quality keyboard equipped with the required connector can be connected with this socket. Check the keyboard for proper function before using it.



### **Note:**

*Since the timing of the integrated controller is optimised for Cherry keyboards, keyboards of this manufacturer should preferably be used.*

*If the screen shows that the soft keyboard is active, controlling the device by using the external keyboard is possible with restrictions only.*

*The keyboard must be connected before switching the device on, since the keyboard interface is initialised while booting! If the keyboard is connected during operation of this device, and the keyboard was not connected during the booting process, it is not operable.*

*The device features an keyboard simulator, which can be used to connect a scanner.*

## 6.5 MOUSE

The green coloured interface "MOUSE" is used to connect a mouse. Check the mouse for compatibility before using it.

PIN NUMBER	SIGNAL NAME
1	Data
2	NC
3	GND
4	+5V
5	Clock
6	NC

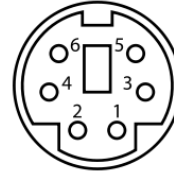

**Note:**

*The mouse must be connected before switching the device on, since the mouse interface is initialised while booting! If the mouse is connected during operation of this device, and the mouse was not connected during the booting process, it is not operable.*

## 6.6 24V DC POWER SUPPLY

The power supply voltage is supplied via a feed-through clamp including screw connection (figure shows socket in the device).

PIN NUMBER	SIGNAL NAME
1	24V DC
2	Ignition contact
3	0V DC

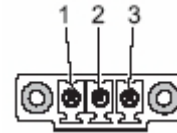

### Voltage tolerance

In the equipment version with a 24V DC  $\pm 20\%$  power supply, a DC-DC converter is integrated.

- Input voltage: 24V DC  $\pm 20\%$ .

### Current consumption

The current consumption of the device at nominal consumption depends on the equipment version of this device.  
(heater, WLAN, etc.)

- Switch-on current: 7 Amperes (for 2ms)
- Standby input current: 0.1 Ampere
- maximum input current using heater: 2.5 Amperes
- Regular operation: 1.5 Amperes without heater



### **Note:**

*The typical power consumption of this device is indicated in the "Technical details" chapter.*

## 6.7 NETWORK CONNECTION (RJ45)

If the drivers required for functioning are installed on the device, the control system may be integrated in an Ethernet network supporting the 10/100 Mbit standard by using the Ethernet 10/100BaseT network connector. Specifications of this network topology must be observed in this case. You can install the drivers required for functioning from the enclosed service CD, should they not be installed on the device.

PIN NUMBER	SIGNAL NAME
1	TX +
2	TX -
3	RX +
4	NC
5	NC
6	RX -
7	NC
8	NC



## 6.8 LINE OUT / SOUND

The Line Out connection of this device is a 3.5 mm socket which provides a stereo signal. In order to use this connection, the matching plug must be wired up as follows.

PIN NUMBER	SIGNAL NAME
Ground	GND
R	Signal, right-hand side
L	Signal, left-hand side

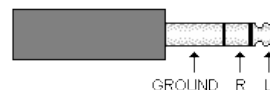

## 6.9 OPTIONAL RADIO NETWORK CARD

If a slot with a radio network card and an externally attached antenna is installed in the device, and if this card is supported by the corresponding drivers in the operating system, this device may be integrated in an Ethernet network supporting 11 Mbit or 54 Mbit (802.11a/b/g compatible) connections. Specifications of this network topology must be observed in this case.

## 7 DRIVES

### 7.1 HARD DRIVES / COMPACT FLASH DRIVES (IDE INTERFACE)

The storage medium is selected according to the customer requirements. The following options are available for storage:

Compact Flash memory:

Compact flash memories with a storage capacity of at least 64 MB are used. The capacity depends on the desired operating system and the additional programmes to be installed.

Hard disk: A 1.8" hard disk with at least 20 GB (UDMA) is used. On delivery, the hard disk is formatted in NTFS format (default for Windows XP).



**Note:**

*Recommendation for selection of storage media with a basic installation:*

*Compact Flash memory: Windows CE.5.0 / Windows XP embedded*

*Hard disk: Windows XP Professional*

### 7.2 EXTERNAL DRIVES

By default, no drive for removable media (CD/floppy disk) is integrated in the device. Additionally the system provides an USB interface, with which an external drive could be connected. In this case, you'd have to ensure that the equipment used is suitable for use in an industrial environment.



**Warning:**

*Connecting or disconnecting of external drives during operation is inadmissible, since it cannot be excluded that the drive is in use at this point in time. Data loss might occur if not observed!*

## 8 SOFTWARE & DRIVER INSTALLATION

The device will be delivered with a pre-installed Windows operating system on request by the customer. The drivers required for this are already installed, and the operating system will be enabled by entering the licence information. Should an initial installation be required, please adhere to the following steps. With a newer operating system like Windows XP, the network card and graphics card will properly be recognised during initial installation, so that only the touchscreen driver and the soft keyboard must be installed separately.



**Note:**

*If the hard drive was formatted, the operating system can be reinstalled by using one of the existing interfaces.*

*An external keyboard is required for installation.*

### 8.1 INSTALLING THE OPERATING SYSTEM

If the device is not equipped with an integrated drive, installing the operating system can only be carried out by using the USB interface.

Procedure for installation:

USB:

- The boot drive in the system Bios must be switched to USB in order to boot the device from the USB interface.
- Restart the device and insert the Windows CD.
- Windows installation and basic data setup
- With devices using a touchscreen, the full functionality range or touchscreen drivers and the soft keyboard should be installed.

If Windows CE.net or Windows XPe is used, the entire operating system may be completely installed from the USB stick using the respective image. The required image can be purchased from the ads-tec company or via the ASSIX online portal.

## 8.2 TOUCHSCREEN DRIVER INSTALLATION



**Note:**

*When installing the drivers, you have to consider that the touchscreen is connected with the serial interface!*

*Touchscreen and PS2 mouse can be used simultaneously*

Installation must be carried out as described below:

- Switch on PC and boot
- Start the installer file in the touchscreen folder by accessing the service CD with the Windows Explorer.
- Follow the instructions on screen and agree to the licensing conditions.
- Once the installer is finished, shut down the computer and restart it.
- After restarting the touchscreen must be calibrated. If the driver does not start automatically, open the setup menu by using the "**Start => Settings => Control panel => Elo Touchscreen**" directory path.
- Start the touchscreen calibration by using the "**Calibration data**" item, and push the crosses, which appear one after another on the screen. If the cursor position coincides with the touch point of your finger on the touchscreen, exit the control box by using the "**OK**" button.

## 8.3 SOFT KEYBOARD

The soft keyboard must be installed from the enclosed CD-ROM in order to enable using the 5 keys (exception: VMT-series, there are 6 keys) underneath the screen. Installation must be carried out as described below:

- Connect the external drive with the device.
- Switch the PC on, and insert the driver CD into the drive after booting.
- Start the installer from the service CD.
- Follow the on-screen instructions, install the driver, select the language and confirm that the computer is going to be restarted.



**Note:**

*Further settings can be performed with respect to the basic settings of the soft keyboard. You'll find information about this in the Readme file in the installation folder for the soft keyboard!*

## 9 TECHNICAL DETAILS

### 9.1 DISPLAY DATA

Display	15" TFT, 1024 x 768 pixels
Display colours	16.7 million colours max
Touchscreen	Resistive industrial touchscreen

### 9.2 COMPUTER DATA

This device may be equipped with the following adsX modules ex factory (according to customer requirements).

<b><u>VERSION 1</u></b>	Pentium M 1.1 GHz 256MB - 2GB DDR RAM Intel 855 GME
-------------------------	---

<b><u>VERSION 2</u></b>	Celeron M 1.0 GHz ULV 256MB - 2GB DDR RAM Intel 855 GME
-------------------------	---

<b><u>VERSION 3</u></b>	Celeron M 800 MHz ULV 256MB - 2GB DDR RAM Intel 855 GME
-------------------------	---

Graphic memory	A maximum of 64 MB, shared memory
Mass storage device	1x plug-in compact flash board
Alternatively:	1,8" hard disk with min. 20 GB (UDMA)
Interfaces	COM 1 (RS232), 1x PS2 mouse, 1x PS2 keyboard, 2x USB 2.0, 1x Mini PCI, 1x PCMCIA, Line Out, 2 internal speakers
Network	1x Ethernet (10/100 Mbit) RJ 45 (Intel 82551QM)
Power supply	24V DC +/- 20%

### 9.3 GENERAL DATA

External dimensions	395 mm x 292 mm x 58 mm (W x H x D)
Weight	approx. 4.8 kg
Protection class	IP 65
Power consumption	25 Watt (typical)
Max. switch-on current	7 Ampere (for 2ms)



## 10 SERVICE AND SUPPORT

The ads-tec company and their partner companies offer a comprehensive service and support to your customers providing a quick and professional support in case of any question with respect to ads-tec products and components.

Since the devices from ads-tec company are also used by partner companies, these devices might be configured according to customer requirements. Should any question or issue with respect to specific configurations and software installations arise, it can only be resolved by the system manufacturer.

For devices not directly purchased from ads-tec, we cannot be responsible for the support. In this case, the support is provided by our partner company.

### 10.1 ADS-TEC SUPPORT

The ads-tec support team is available for direct clients from Monday to Friday from 08:30 AM to 05:00 PM using the following phone number:

Phone: +49 (0) 711 / 45894-500

Fax: +49 (0) 711 / 45894-990

Email: [info@ads-tec.com](mailto:info@ads-tec.com)

### 10.2 COMPANY ADDRESS

ads-tec  
Automation Daten- und Systemtechnik GmbH  
Raiffeisenstraße 14  
D-70771 Leinfelden-Echterdingen  
Germany

Phone: +49 (0) 711 / 45894-0

Fax: +49 (0) 711 / 45894-990

Email: [info@ads-tec.de](mailto:info@ads-tec.de)

Home: [www.ads-tec.de](http://www.ads-tec.de)