



A Precise Positioning Technology Company



SPAN-CPT™

User Manual

OM-20000122

Rev 7

May 2013



SPAN-CPT Receiver User Manual

Publication Number: OM-20000122
Revision Level: Rev 7
Revision Date: May 2013

This manual reflects SPAN-CPT Firmware Version OEM060220RN0000.

Warranty

NovAtel Inc. warrants that its GNSS products are free from defects in materials and workmanship, subject to the conditions set forth on our web site: www.novatel.com/products/warranty/ and for the following time periods:

SPAN-CPT™ receiver	One (1) Year
GPS Antenna™ Series	One (1) Year
Cables and Accessories	Ninety (90) Days
Software Warranty	One (1) Year

Return instructions

To return products, refer to the instructions at the bottom of the Warranty page: www.novatel.com/products/warranty/.

Proprietary Notice

Information in this document is subject to change without notice and does not represent a commitment on the part of NovAtel Inc. The software described in this document is furnished under a licence agreement or non-disclosure agreement. The software may be used or copied only in accordance with the terms of the agreement. It is against the law to copy the software on any medium except as specifically allowed in the license or non-disclosure agreement.

No part of this manual may be reproduced or transmitted in any form or by any means, electronic or mechanical, including photocopying and recording, for any purpose without the express written permission of a duly authorized representative of NovAtel Inc.

The information contained within this manual is believed to be true and correct at the time of publication.

NovAtel, SPAN, OEM6 and ProPak and are registered trademarks of NovAtel Inc.

NovAtel Connect and SPAN-CPT are trademarks of NovAtel Inc.

All other product or brand names are trademarks of their respective holders.

Manufactured and protected under U.S. patents:

NovAtel Patents		KVH Technology Patents		
#5,101,416	#6,243,409 B1	#5,444,534	#6,351,310 B1	#6,763,153
#5,390,207	#6,664,923 B1	#5,481,358	#6,370,289 B1	#6,836,334
#5,414,729	#6,721,657 B2	#5,512,904	#6,429,939	#6,856,300
#5,495,499	#6,750,816 B1	#5,552,887	#6,441,779	#6,864,347
#5,736,961	#7,193,559 B2	#5,739,944	#6,466,596	#6,891,622
#5,809,064	#7,738,536 B2	#5,768,462	#6,542,651	#7,120,323
#6,184,822 B1	#7,738,606 B2	#6,041,149	#6,594,020	
#6,608,998 B1	#7,346,452	#6,134,356	#6,718,097	
#6,728,637 B2	#7,885,317 B2			
#6,922,167 B2				

© Copyright 2013 NovAtel Inc. All rights reserved. Unpublished rights reserved under International copyright laws.

Table of Contents

Customer Support	7
Notices	8
1 Introduction	11
1.1 Fundamentals of GNSS/INS	11
1.2 System Components	12
1.3 Related Documents and Information	12
1.4 Conventions	12
2 SPAN-CPT Installation	13
2.1 Required Equipment.....	13
2.1.1 Manuals.....	13
2.1.2 SPAN-CPT Hardware	13
2.2 Hardware Set Up.....	14
2.2.1 Mount the Antenna.....	15
2.2.2 Mount the SPAN-CPT	15
2.2.3 Connect the GNSS Antenna	16
2.2.4 Connect Power.....	16
2.2.5 Connect a Computer to the SPAN-CPT	17
2.2.6 Connect the I/O Strobe Signals.....	17
2.2.7 CAN Bus	18
2.2.8 Odometer Connection	18
3 SPAN-CPT Operation	20
3.1 Definition of Reference Frames Within SPAN.....	20
3.1.1 The Local Level Frame	20
3.1.2 The SPAN Body Frame.....	21
3.1.3 The Enclosure Frame.....	22
3.1.4 The Vehicle Frame.....	22
3.2 Communicating with the SPAN-CPT System	23
3.2.1 Use NovAtel Connect to Communicate.....	23
3.2.2 INS Window in NovAtel Connect.....	24
3.3 Software Configuration.....	25
3.3.1 GNSS Configuration.....	25
3.3.2 SPAN IMU Configuration	25
3.4 Real Time Operation	27
3.4.1 System Start-Up and Alignment Techniques	28
3.4.2 Navigation Mode	29
3.4.3 Vehicle to SPAN-CPT Frame Angular Offsets Calibration Routine	30
3.4.4 SPAN-CPT Wheel Sensor	31
3.5 Azimuth Sources on a SPAN System	31
3.5.1 Course Over Ground.....	31
3.5.2 Inertial Azimuth	31
3.5.3 ALIGN Azimuth	31
3.6 Data Collection	32
3.7 Data Collection for Post-Processing.....	33
3.8 Variable Lever Arm.....	34
4 SPAN-CPT Dual-Antenna	35
4.1 Installation	35
4.2 Configuring ALIGN with SPAN-CPT.....	36
4.3 Configuring SPAN with ALIGN on SPAN-CPT.....	37
4.3.1 Alignment on a Moving Vessel - Aided Transfer Alignment	37
4.3.2 Alignment on a Stationary Vehicle - Aided Static Alignment.....	38
4.3.3 Unaided Alignment.....	38
4.3.4 Automatic Alignment Mode - Automatic Alignment (default).....	38

4.4 SPAN ALIGN Attitude Updates	38
5 NovAtel Firmware and Software	39
5.1 Firmware Updates and Model Upgrades	40
5.1.1 Firmware Updates	40
5.1.2 Model Upgrades	41
5.2 Authorization Code	42
5.3 Updating or Upgrading Using the WinLoad Utility	44
5.3.1 Transferring Firmware Files	44
5.3.2 Using the WinLoad Utility	44
5.4 Updating using SoftLoad Commands	47
5.4.1 Working with S-Records	48
5.5 Upgrading Using the AUTH Command	49
5.5.1 Upgrade Procedure	49
5.6 Key Firmware Commands	50
A Technical Specifications	51
A.1 SPAN-CPT Technical Specifications	51
A.2 SPAN-CPT Mechanical Drawings	53
A.3 SPAN-CPT Cable	54
B Replacement Parts	58
B.1 SPAN-CPT System	58
B.2 Accessories and Options	58
C Frequently Asked Questions	59

Figures

1	Primary and Secondary Lightning Protection	10
2	SPAN-CPT Receiver	13
3	Typical SPAN-CPT Set Up	14
4	SPAN-CPT Enclosure Mounting	15
5	Battery Isolator Installation	17
6	I/O Strobe Signals	17
7	Kistler WPT	18
8	Local Level Frame (ENU)	20
9	SPAN-CPT Center of Navigation	22
10	Vehicle Frame	23
11	SPAN-CPT - Dual Antenna Installation	36
12	WinLoad's Open Window	45
13	Open File in WinLoad	45
14	COM Port Setup	45
15	Searching for Card	46
16	Authorization Code Window	46
17	Upgrade Process Complete	46
18	SPAN-CPT Side and Perspective View	53
19	SPAN-CPT Top, Front and Bottom View	54
20	SPAN-CPT Development Terminated Cable	55

Tables

1	Cable Modification for Kistler WPT Cable.....	19
2	Cable Modification for SPAN-CPT Cable	19
3	Full Mapping Definitions.....	21
4	Inertial Solution Status	27
5	Logs with Azimuth data.....	32
6	Solution Parameters.....	32
7	Hardware Specification for SPAN-CPT.....	51
8	KVH IMU Sensor Specifications.....	51
9	Electrical and Environmental Specifications	52
10	Power Specifications	52
11	SPAN-CPT 60723108 - KVH Development Terminated Cable Pin-Out.....	55
12	SPAN-CPT 60723107 - KVH Standard Un-terminated Cable Pin-Out	57

Customer Support

NovAtel Knowledge Base

If a technical issue is encountered, browse the NovAtel Web site at www.novatel.com/ then select Support | Helpdesk and Solutions | Search Known Solutions. Use this page to search for general information about GNSS and other technologies, information about NovAtel hardware and software and installation and operation issues.

Before Contacting Customer Support

Before contacting NovAtel Customer Support about a software problem, perform the following steps:

1. Log the following data to a file on your computer for 15 minutes:

RXSTATUSB once
RAWEPHEMB onchanged
RANGEB ontime 1
BESTPOSB ontime 1
RXCONFIGA once
VERSIONB once
RAWIMUSXB onnew
INSPVASB ontime 1
INSCOVSB ontime 1
INSUPDATEB onchanged
IMUTOANTOFFSETSB onchanged

Send the file containing the log to NovAtel Customer Support, using either the NovAtel FTP site at Support | Firmware/Software and Manuals | Access FTP Site on the NovAtel Web site at <http://www.novatel.com/> or through the support@novatel.com e-mail address.

2. You can also issue a `FRESET` command to the receiver to clear any unknown settings.



The `FRESET` command erases all user settings. Record the configuration settings before sending the `FRESET` command to simplify reconfiguration.

If a hardware problem is encountered, send a list of the troubleshooting steps taken and results.

Contact Information

Use one of the following methods to contact NovAtel Customer Support:

Call the NovAtel Hotline at 1-800-NOVATEL (U.S. & Canada) or +1-403-295-4500 (international)	
Fax: +1-403-295-4501 E-mail: support@novatel.com Web site: http://www.novatel.com	Write: NovAtel Inc. Customer Support Department 1120 - 68 Avenue NE Calgary, AB Canada, T2E 8S5

Notices

The following notices apply to the SPAN-CPT.

FCC Notices

This device complies with part 15 of the FCC Rules. Operation is subject to the following two conditions: (1) this device may not cause harmful interference, and (2) this device must accept any interference received, including interference that may cause undesired operation.

SPAN-CPT complies with the radiated and conducted emission limits for a Class B digital device. The Class B limits are designed to provide reasonable protection against harmful interference in a residential installation.

The equipment listed generates, uses, and can radiate radio frequency energy and, if not installed and used in accordance with the instructions, may cause harmful interference to radio communications. However, there is no guarantee that interference will not occur in a particular installation. If this equipment does cause harmful interference to radio or television reception, which can be determined by turning the equipment off and on, the user is encouraged to try to correct the interference by one or more of the following measures:

- Re-orient or relocate the receiving antenna
- Increase the separation between the equipment and the receiver
- Connect the equipment to an outlet on a circuit different from that to which the receiver is connected
- Consult the dealer or an experienced radio/TV technician for help



In order to maintain compliance with the limits of a Class B digital device, it is required to use properly shielded interface cables (such as Belden #9539 or equivalent) when using the serial data ports, and double-shielded cables (such as Belden #9945 or equivalent) when using the I/O strobe port.



Changes or modifications to this equipment, not expressly approved by NovAtel Inc., could result in violation of FCC, Industry Canada and CE Marking rules and void the user's authority to operate this equipment.

CE Notice

The enclosures carry the CE mark.

"Hereby, NovAtel Inc. declares that this SPAN-CPT is in compliance with the essential requirements and other relevant provisions of Directive 1999/5/EC."

WEEE Notice

If you purchased your SPAN-CPT product in Europe, please return it to your dealer or supplier at the end of its life. The objectives of the European Community's environment policy are, in particular, to preserve, protect and improve the quality of the environment, protect human health and utilise natural resources prudently and rationally. Sustainable development advocates the reduction of wasteful consumption of natural resources and the prevention of pollution. Waste electrical and electronic equipment (WEEE) is a regulated area. Where the generation of waste cannot be avoided, it should be reused or recovered for its material or energy. WEEE products may be recognized by their wheeled bin label ()¹.

Lightning Protection Installation and Grounding Procedure

What is the hazard?

A lightning strike into the ground causes an increase in the earth's potential which results in a high voltage potential between the center conductor and shield of the coaxial cable. This high voltage develops because the voltage surge induced onto the center conductor lags in time behind the voltage surge induced onto the shield.

Hazard Impact

A lightning strike causes the ground potential in the area to rise to dangerous levels resulting in harm to personnel or destruction of electronic equipment in an unprotected environment. It also conducts a portion of the strike energy down the inner conductor of the coax cable to the connected equipment.



Only qualified personnel, electricians as mandated by the governing body in the country of installation, may install lightning protection devices.

Actions to Mitigate Lightning Hazards

1. Do not install antennas or antenna coaxial cables outside the building during a lightning storm.
2. It is not possible to avoid over-voltages caused by lightning, but a lightning protection device may be used to shunt a large portion of the transient energy to the building ground reducing the over-voltage condition as quickly as possible.
3. Primary lightning protection must be provided by the operator/customer according to local building codes as part of the extra-building installation.
4. To ensure compliance with clause 7 "Connection to Cable Distribution Systems" of EN 60950-1, Safety for Information Technology Equipment, a secondary lightning protection device must be used for in-building equipment installations with external antennas. The following device has been approved by NovAtel Inc.:

Polyphaser - Surge Arrestor DGXZ+24NFNF-A

If this device is not chosen as the primary lightning protection device, the device chosen must meet the following requirements:

- UL listed, or equivalent, in country of installation (for example, TUV, VDE and so on) for lightning surge protection
 - The primary device must be capable of limiting an incoming surge to 10kV
5. The shield of the coaxial cable entering the building should be connected at a grounding plate at the building's entrance. The lightning protection devices should have their chassis grounded to the same ground near to the building's entrance.
 6. The primary and secondary lightning protections should be as close to the building's entrance as possible. Where feasible they should be mounted onto the grounding plate itself (refer to the following figure).

1. Visit the NovAtel Web site at www.novatel.com through *Products | WEEE and RoHS* for more information on WEEE.

Figure 1: Primary and Secondary Lightning Protection

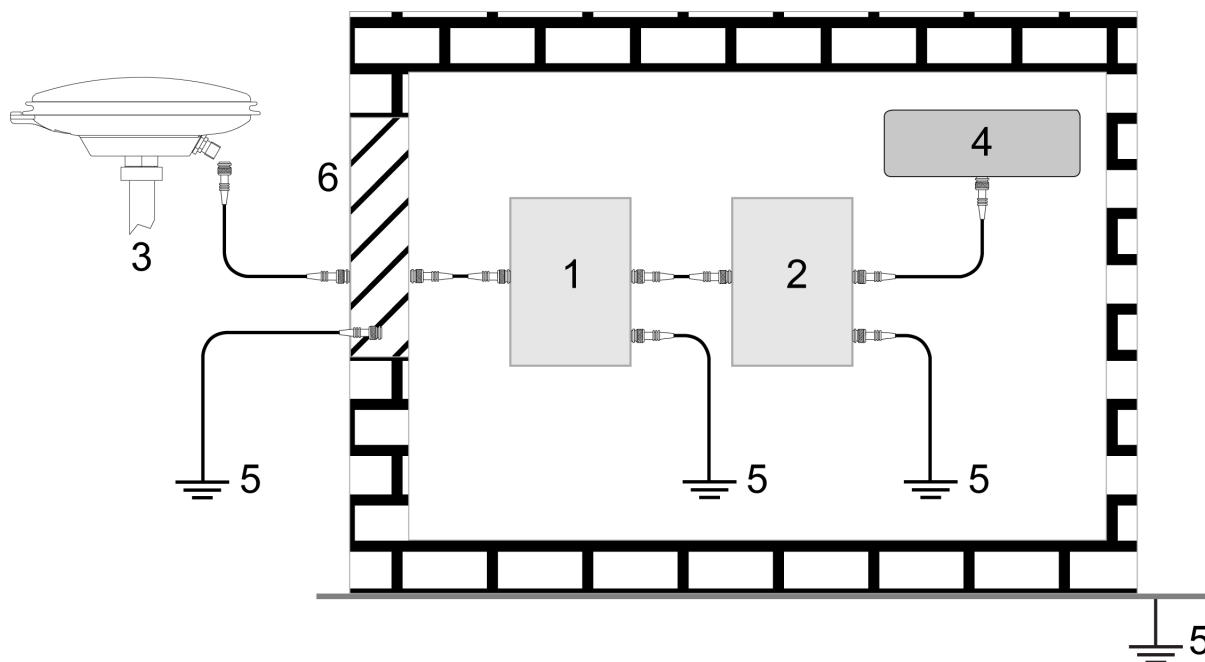

Ref #	Description
1	Primary lightning protection device
2	Secondary lightning protection device
3	External antenna
4	GNSS Receiver
5	To ground
6	Grounding plate or grounding point at the building's entrance



Acceptable choices for Earth Grounds, for central buildings, are:

- Grounded interior metal cold water pipe within five feet (1.5 m) of the point where it enters the building
- Grounded metallic service raceway
- Grounded electrical service equipment enclosure
- Eight-foot grounding rod driven into the ground (only if bonded to the central building ground by #6, or heavier, bonding wire)

These installation instructions are the minimum requirements for receiver and antenna installations. Where applicable, follow the electrical codes for the country of installation. Examples of country codes include:

- USA National Electrical Code (NFPA 70)
- Canada Canadian Electrical Code (CSA C22)
- UK British Standards Institute (BSI 7671)

NovAtel's SPAN® (Synchronized Position Attitude Navigation) technology brings together two different but complementary positioning and navigation systems: GNSS and an Inertial Navigation System (INS). By combining the best aspects of GNSS and INS into one system, SPAN technology offers a solution that is more accurate and reliable than either GNSS or INS alone. The combined GNSS/INS solution has the advantage of the absolute accuracy available from GNSS and the continuity of INS through traditionally difficult GNSS conditions.

SPAN-CPT combines GNSS and Inertial Measurement Unit (IMU) hardware inside a single enclosure for simple installation and operation. NovAtel's OEM6® receiver is the processing engine of SPAN-CPT and the IMU components are manufactured by KVH Industries. Commercial components are used in SPAN-CPT to offer the same benefits of other SPAN products, but with fewer export restrictions.

1.1 Fundamentals of GNSS/INS

GNSS positioning observes range measurements from orbiting Global Positioning System Satellites. From these observations, the receiver computes position and velocity with high accuracy. NovAtel GNSS positioning systems are highly accurate positioning tools. GNSS however does have some significant restrictions which limit its usefulness in some situations. GNSS positioning requires line of site view to at least four satellites simultaneously. If this criteria is met, differential GNSS positioning can be accurate to within a few centimetres. If however, some or all the satellite signals are blocked, the accuracy of the position reported by GNSS degrades substantially or may not be available at all.

An INS uses forces and rotations measured by an IMU to calculate position, velocity and attitude. This capability is embedded in the firmware of the SPAN-CPT. Forces are measured by accelerometers in three perpendicular axes within the IMU and the gyros measure angular rotation rates around those axes. Over short periods of time, inertial navigation gives very accurate acceleration, velocity and attitude output. The INS must have prior knowledge of its initial position, initial velocity, initial attitude, Earth rotation rate and gravity field. Since the IMU measures changes in orientation and acceleration, the INS determines changes in position and attitude, but initial values for these parameters must be provided from an external source. Once these parameters are known, an INS is capable of providing an autonomous solution with no external inputs. However, because of errors in the IMU measurements that accumulate over time, an inertial only solution degrades with time unless external updates such as position, velocity or attitude are supplied.

The SPAN-CPT system's combined GNSS/INS solution integrates the raw inertial measurements with all available GNSS information to provide the optimum solution possible in any situation. By using the high accuracy GNSS solution, IMU errors can be modeled and mitigated. Conversely, the continuity and relative accuracy of the INS solution enables faster GNSS signal reacquisition and Real Time Kinematic (RTK) solution convergence.

The advantages of using SPAN-CPT technology are its ability to:

- Provide a full attitude solution (roll, pitch and azimuth)
- Provide continuous solution output (in situations when a GNSS-only solution is impossible)
- Provide faster signal reacquisition and RTK solution resolution (over stand alone GNSS because of the tightly integrated GNSS and INS filters)
- Output high rate (up to 100 Hz) position, velocity and attitude solutions for high dynamic applications, see also *Logging Restriction* on page 33.
- Use raw phase observation data (to constrain INS solution drift even when too few satellites are available for a full GNSS solution)

1.2 System Components

The SPAN-CPT system consists of the following components:

- SPAN-CPT Integrated INS/GNSS receiver – This receiver has 3 accelerometers, 3 gyroscopes (gyros) and a NovAtel OEM6 receiver. Excellent acquisition and reacquisition times allow the receiver to operate in environments where very high dynamics and frequent interruptions of signals can be expected.
- A GNSS antenna
- Computer software – Real time data collection, status monitoring and receiver configuration is possible through the NovAtel Connect™ software utility (refer to *SPAN-CPT Configuration with NovAtel Connect* on page 25).

1.3 Related Documents and Information

This manual contains sufficient information about the installation and operation of the SPAN-CPT system. It is beyond the scope of this manual to provide details on service or repair. Contact your local NovAtel dealer for any customer service related inquiries, see *Customer Support* on page 7.

The SPAN-CPT utilizes a comprehensive user interface command structure, which requires communications through its communication (COM) ports. For information about the INS-specific commands and logs, see the [SPAN on OEM6 Firmware Reference Manual](#) (OM-20000144). For descriptions of the other commands and logs available with SPAN-CPT, refer to the [OEM6 Family Firmware Reference Manual](#) (OM-20000129). Both of these manuals are available on the NovAtel website at www.novatel.com/support/firmware-software-and-manuals/product-manuals-and-doc-updates/. It is recommended that these documents be kept together for easy reference.

SPAN-CPT system output is compatible with post-processing software from NovAtel's Waypoint® Products Group. Visit our Web site at www.novatel.com for details.

1.4 Conventions

The following conventions are used in this manual:



Information that supplements or clarifies text.



A caution that actions, operation or configuration may lead to incorrect or improper use of the hardware.



A warning that actions, operation or configuration may result in regulatory noncompliance, safety issues or equipment damage.

This chapter contains instructions and tips to setup your SPAN-CPT system.

2.1 Required Equipment

- A SPAN-CPT integrated GNSS/INS receiver
- A quality, dual frequency GNSS antenna such as the GPS-702-GG or ANT-A72GA-TW-N. See the NovAtel website (www.novatel.com/products/gnss-antennas/) for information on a variety of quality antennas available to meet your form factor and performance needs.
- An antenna cable with a TNC male connector at the receiver end, such as NovAtel's GPS-C016 model
- A power supply of +9 to +18 VDC
- An interface cables for the multi-purpose I/O connector on the SPAN-CPT. The interface cables can be NovAtel cables (see *SPAN-CPT Cable* on page 54) or custom built cables (see *Appendix A, Technical Specifications* on page 51 for the multi-purpose I/O connector pin outs).
- A Windows® based computer with a USB or serial port
- A radio link (if the application requires real time differential operation)

2.1.1 Manuals

The following additional manuals may be required for reference and are available from the [NovAtel web site](#).

- [SPAN on OEM6 Firmware Reference Manual](#) (OM-20000144)
- [OEM6 Family Firmware Reference Manual](#) (OM-20000129)
- [OEM6 Family Installation and Operation Manual](#) (OM-20000128)

2.1.2 SPAN-CPT Hardware

The SPAN-CPT receiver contains an OEM6 receiver and an IMU containing 3 accelerometers and 3 gyroscopes. Communication is done using either the COM ports or USB through the multi-I/O connector.

Figure 2: SPAN-CPT Receiver



The sections that follows outline how to set up the system's parts and cables. Refer to *Appendix A, Technical Specifications* on page 51 for details.



Use a USB cable to log raw data - Serial communication is sufficient for configuring and monitoring the receiver through Hyperterminal or NovAtel Connect. USB is required if using a post-processing application requiring 100 Hz IMU data. We also recommend using NovAtel Connect to collect the data. Refer to *Data Collection* on page 32 and *Data Collection for Post-Processing* on page 33 for instructions.

2.2 Hardware Set Up

Complete the following steps to set up the NovAtel SPAN system.

Figure 3: Typical SPAN-CPT Set Up

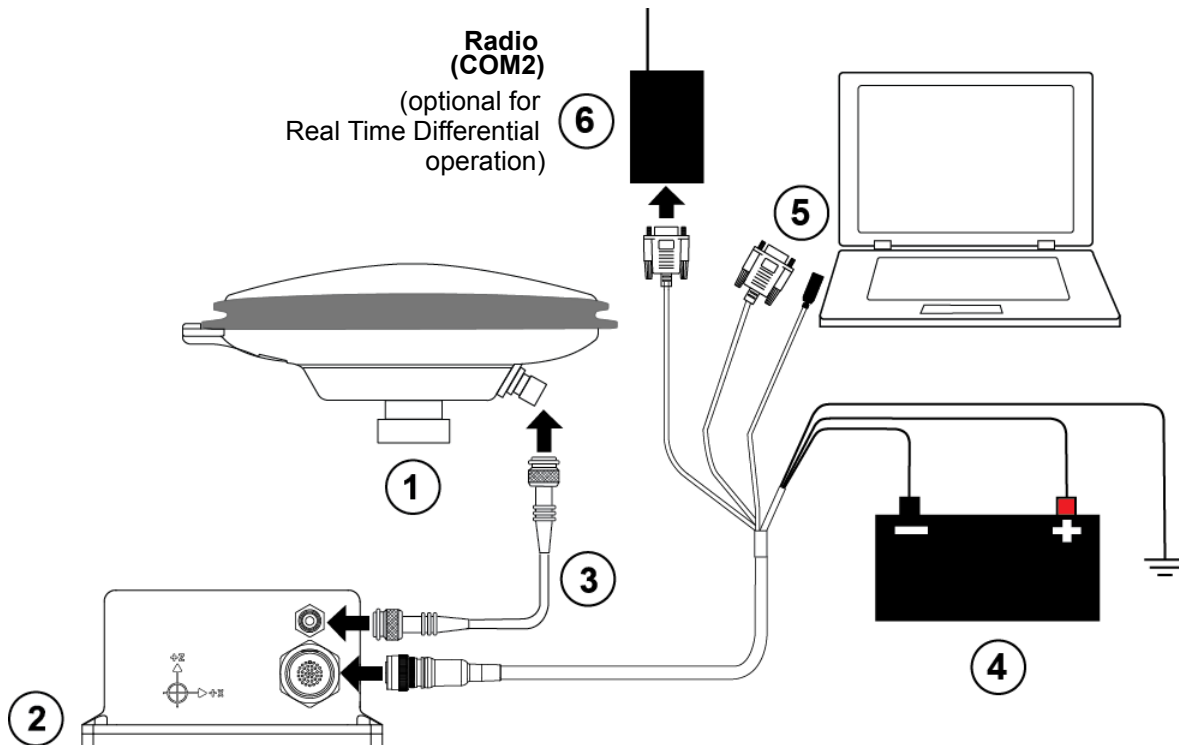

1. Mount the GNSS antenna, as described in *Mount the Antenna* on page 15.
2. Mount the SPAN-CPT, as described in *Mount the SPAN-CPT* on page 15.
3. Connect the GNSS antenna to the SPAN-CPT, as described in *Connect the GNSS Antenna* on page 16.
4. Connect power to the SPAN-CPT, as described in *Connect Power* on page 16.
5. Connect a computer to the SPAN-CPT, as described in *Connect a Computer to the SPAN-CPT* on page 17.
6. Connect the serial port on the user supplied radio device (optional for real-time differential operation) to the COM2 port available on the multi-purpose I/O connector.
7. Connect the I/O strobe signals (optional), as described in *Connect the I/O Strobe Signals* on page 17.



NovAtel recommends tying to ground any floating input lines.

2.2.1 Mount the Antenna

For maximum positioning precision and accuracy, as well as to minimize the risk of damage, ensure the antenna is securely mounted on a stable structure that will not sway or topple. Where possible, select a location with a clear view of the sky to the horizon so each satellite above the horizon can be tracked without obstruction. The location should also be one that minimizes the effect of multipath interference. Ensure the antenna cannot move due to dynamics.

For a discussion on multipath, refer to NovAtel's GNSS book [An Introduction to GNSS](#).

2.2.2 Mount the SPAN-CPT

Mount the SPAN-CPT in a fixed location where the distance from the SPAN-CPT to the GNSS antenna phase center is constant. Ensure the SPAN-CPT orientation, with respect to the vehicle and antenna, is also constant.

For attitude output to be meaningful, the SPAN-CPT should be mounted so the positive Z-axis marked on the SPAN-CPT enclosure points up and the Y-axis points forward through the front of the vehicle, in the direction the vehicle is moving.

Figure 4: SPAN-CPT Enclosure Mounting

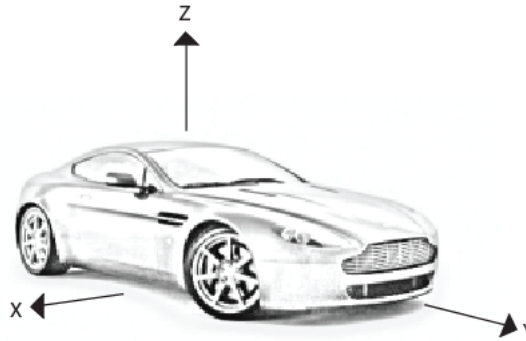

Also, it is important to measure the distance from the SPAN-CPT to the antenna (the Antenna Lever Arm), on the first usage, on the axis defined on the SPAN-CPT enclosure. See also *Appendix A, Technical Specifications* on page 51 for dimensional drawings of the SPAN-CPT.

Ensure they cannot move due to dynamics and that the distance and relative direction between them is fixed.



The closer the antenna is to the SPAN-CPT, the more accurate the position solution. Also, your measurements when using the `SETIMUTOANTOFFSET` command must be as accurate as possible or at least more accurate than the GNSS positions being used. For example, a 10 cm error in recording the antenna offset results in at least a 10 cm error in the output. Millimeter accuracy is preferred.

The offset from the SPAN-CPT to the antenna and/or a user point device, must remain constant especially for RTK or DGNSS data. Ensure the SPAN-CPT, antenna and user point device are bolted in one position perhaps by using a custom bracket.

2.2.3 Connect the GNSS Antenna

Connect the antenna cable from the connector on the GNSS antenna to the antenna port on the SPAN-CPT. See *Typical SPAN-CPT Set Up* on page 14.



The SPAN-CPT can supply power for the antenna Low Noise Amplifier (LNA) through the antenna port center conductor. The SPAN-CPT provides +5 VDC \pm 5% at a maximum of 100 mA.

For best performance, use a high quality coaxial cable. An appropriate coaxial cable is one that matches the impedances of the antenna and receiver (50 ohms) and has a line loss that does not exceed 10.0 dB. If the limit is exceeded, excessive signal degradation may occur and the receiver may not meet performance specifications.



NovAtel offers several coaxial cables to meet your GNSS antenna interconnection requirements, including 5, 15 and 30 m antenna cable with TNC connectors on both ends (NovAtel part numbers GPS-C006, GPS-C016 and GPS-C032).

If your application requires the use of cable longer than 30 m, refer to application note *APN-003 RF Equipment Selection and Installation*, available at www.novatel.com/support/knowledge-and-learning/published-papers-and-documents/application-notes/.

2.2.4 Connect Power

The SPAN-CPT receiver requires an input supply voltage of +9 VDC to +18 VDC. The receiver has an internal power module that does the following:

- filters and regulates the supply voltage
- protects against over voltage, over current, and high temperature conditions
- provides automatic reset circuit protection

Power input pins are located on the multi-purpose I/O connector. Be sure to connect the power with the correct polarity and ensure the power source is within specifications. See *Appendix A, Technical Specifications* on page 51 for the multi-purpose I/O connector pin out and the power input requirements.

There is always a drop in voltage between the power source and the power port due to cable loss. Improper selection of wire gauge can lead to an unacceptable voltage drop at the SPAN-CPT system. A paired wire run represents a feed and return line. Therefore, a 2 m wire pair represents a total wire path of 4 m. For a SPAN-CPT system operating from a 12 V system, a power cable longer than 2.1 m (7 ft.) should not use a wire diameter smaller than 24 AWG.



The power supply used to power the SPAN-CPT must be monotonic during power on to ensure internal logic blocks are initialized appropriately and proceed to valid operating states. If the power supply is not monotonic during power on, the accelerometer status in the IMU status may show a failure and the accelerometer measurements in the RAWIMUS log (see the RAWIMUS log description in the [OEM6 Family Firmware Reference Manual](#) (Om-20000129)) will be zero. Power cycling with a monotonic power up clears this error state.

If the SPAN-CPT is installed in a vehicle, NovAtel recommends a backup battery be placed between the receiver and its voltage supply to act as a power buffer. When a vehicle engine is started, power can dip or cut out to ancillary equipment causing the receiver and IMU to lose lock and calibration settings.



The SPAN-CPT contains a breaker which can be tripped if using an incorrect power supply. Manually power cycle the SPAN-CPT to reset the breaker and reconnect to a properly supported power supply.

Figure 5: Battery Isolator Installation

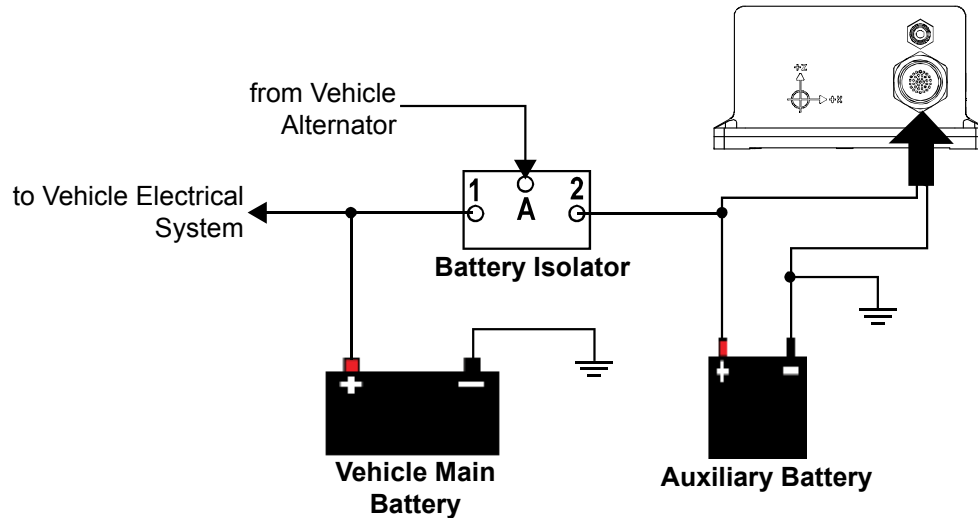

2.2.5 Connect a Computer to the SPAN-CPT

SPAN-CPT has a multi-purpose I/O connector that contains pins for the COM1 serial port, COM2 serial port and USB port. Refer to *Appendix A, Technical Specifications* on page 51 for the pin definitions of the multi-purpose I/O connector.

To use a USB connection, connect the USB port pins on the multi-purpose I/O connector to the USB port on the computer.

To use a serial connection, connect the COM1 or COM2 port pins on the multi-purpose I/O connector to the serial port on the computer.



By default, COM1 operates as an RS-232 serial port. To change COM1 to operate as an RS-422 serial port, tie together the RS-422 select pins (7 and 8) on the multi-purpose I/O connector.

2.2.6 Connect the I/O Strobe Signals

The SPAN-CPT has several I/O strobe signals enabling it to be part of an interconnected system composed of devices that need to be synchronized with each other. For example, connect the SPAN system to an aerial camera in such a way that the SPAN system records its position whenever the shutter button is pressed.

The SPAN-CPT supports the strobe signals described in *Table 6, I/O Strobe Signals*. These signals are accessed from the multi-purpose I/O connector on the SPAN-CPT. See *Appendix A, Technical Specifications* on page 51 for information on signals, wiring and pin-out information of the multi-purpose I/O connector.

Figure 6: I/O Strobe Signals

Signal	Description ^a
Event1 (Mark 1)	An input signal for which a pulse greater than 150 ns triggers certain logs to be generated. Polarity is configurable using the <code>MARKCONTROL</code> command.
PPS (Pulse Per Second)	A time synchronization output. This is a pulse where the leading edge is synchronized to receiver calculated GNSS Time. The polarity, period and pulse width can be configured using <code>PPSCONTROL</code> command.

- a. For information about the `SETMARK1OFFSET` and `TAGGEDMARK1PVA` commands, refer to the [SPAN on OEM6 Firmware Reference Manual](#) (OM-20000144). For information about the other commands and logs in this table, refer to the [OEM6 Family Firmware Reference Manual](#) (Om-20000129).

2.2.7 CAN Bus

The SPAN-CPT has a CAN Bus controller that supports physical layer signals and low level messages specified in the appropriate sections of the J1939 and ISO11783 standards. Manufacturers can also create messages specific to their application without violating these standards. To facilitate manufacturer messages, NovAtel provides an Application Program Interface (API). To obtain information about this API, contact NovAtel Customer Support.

The CAN Bus port is available on the multi-purpose I/O connector on the SPAN-CPT. See *Appendix A, Technical Specifications* on page 51 for information on signals, wiring and pin-out information of the multi-purpose I/O connector.

2.2.8 Odometer Connection

The SPAN-CPT provides a wheel sensor input for a Distance Measurement Instrument (DMI) through the multi-purpose I/O connector. Refer to *SPAN-CPT Wheel Sensor* on page 31 for additional details.

2.2.8.1 Odometer Requirements

SPAN-CPT is compatible with any wheel sensor meeting the following requirements:

- Input range less than or equal to 45 KHz
- Input duty cycle is symmetric 40%-60%
- Active input voltage is greater than or equal to 2.5 VDC with a maximum input voltage of 50 VDC
- Inactive voltage is less than or equal to 1 VDC
- Input current is approximately 3.5 mA at 5 VDC with a maximum of 5 mA at 50 VDC
- Ensure input current does not exceed 5 mA. There is a current limiting diode that can dissipate 800 mW on the input opto-isolator
- Quadrature, pulse and direction type odometers are compatible

An example of a SPAN-CPT compatible odometer is the CWPTA411 from Kistler (www.kistler.com). A transducer traditionally fits to the outside of a non-drive wheel. A pulse is then generated from the transducer which is fed directly to the ODO connector on the IMU cable.

Figure 7: Kistler WPT



The Wheel Pulse Transducer (WPT) mounts to the wheel lug nuts via adjustable mounting collets. The torsion protection rod, which maintains rotation around the wheel axis, affixes to the vehicle body with suction cups. Refer to the Kistler WPT (part number CWPTA411) user manual for mounting instructions (www.kistler.com).

SPAN-CPT powers the odometer. See *SPAN-CPT Cable* on page 54 for the pin outs of the SPAN-CPT cable. Connect the appropriate pins to the chosen odometer. If the Kistler WPT is chosen, first modify the cable at the WPT end. The cable modifications are shown in *Table 1, Cable Modification for Kistler WPT Cable* and *Table 2, Cable Modification for SPAN-CPT Cable* on page 19.

Table 1: Cable Modification for Kistler WPT Cable

8-pin M12 Connector on the Kistler Cable (part # CWPTA41) ^a		Female DB9 Connector
Pin 1	GND	Pin 5
Pin 2	+U _B (Input Power)	Pin 9
Pin 3	Signal A	Pin 6
Pin 4	Signal A inverted	Pin 7
Pin 5	Signal B	Pin 3
Pin 6	Signal B inverted	Pin 1
Pin 7	Reserved	No change
Pin 8		

a. This modification is for the Kistler WPT 8-pin M12-plug cable number 14865.



Kistler provides an M12 to DB9 cable for use with the WPT. However, certain revisions of this cable do not bring through all four signal inputs. The SPAN-CPT odometer interface requires all four signal inputs to operate correctly. See your WPT documentation for cable details.

Table 2: Cable Modification for SPAN-CPT Cable

Pin Wires on SPAN-CPT-KVH Terminated or Unterminated Cable		Male DB9 Connector
18	ODO SIGNAL B INV	Pin 1
NONE		Pin 2
17	ODO SIGNAL B	Pin 3
NONE		Pin 4
14	GND	Pin 5
15	ODO SIGNAL A	Pin 6
16	ODO SIGNAL A INV	Pin 7
NONE		Pin 8
13	INPUT POWER	Pin 9

Before operating the SPAN-CPT system, ensure that the installation and set up instructions in *Chapter 2, SPAN-CPT Installation* on page 13 were completed.

Use the NovAtel Connect software to configure receiver settings and to monitor data in real time, between a rover SPAN-CPT system and base station.

SPAN-CPT system output is compatible with post-processing software from NovAtel's Waypoint Products Group. For information about Waypoint, visit our Web site at <http://www.novatel.com/products/software/waypoint-products/>.



Ensure the computer's Control Panel Power Settings are not set to go into Hibernate or Standby modes. Data is lost if one of these modes occur during a logging session.

3.1 Definition of Reference Frames Within SPAN

The reference frames most frequently used throughout this manual are:

- The Local Level Frame
- The SPAN Body Frame
- The Enclosure Frame
- The Vehicle Frame

3.1.1 The Local Level Frame

The definition of the local level coordinate frame is as follows:

- z-axis pointing up (aligned with gravity)
- y-axis pointing north
- x-axis pointing east

Figure 8: Local Level Frame (ENU)

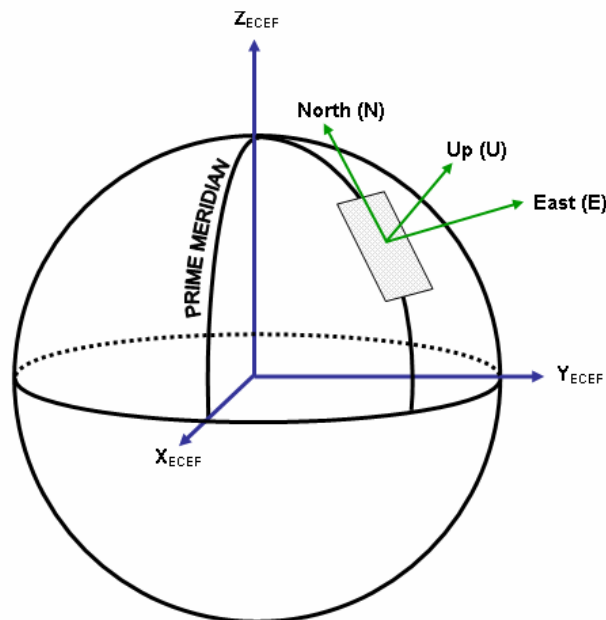

3.1.2 The SPAN Body Frame

The definition of the SPAN body frame is as follows:

- z-axis pointing up (aligned with gravity)
- y-axis defined by how user has mounted the IMU
- x-axis defined by how user has mounted the IMU

To determine the SPAN x-axis and y-axis, see *Table 3, Full Mapping Definitions* on page 21. This frame is also known as the computation frame and is the frame where all the mechanization equations are computed.

Table 3: Full Mapping Definitions

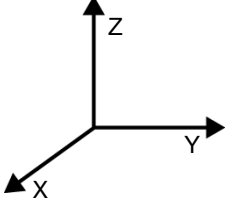
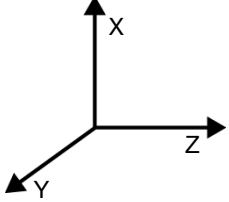
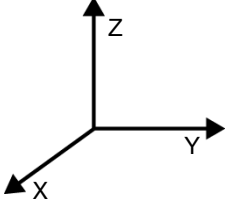
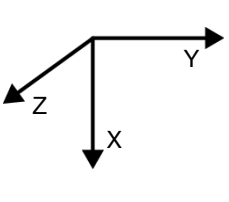
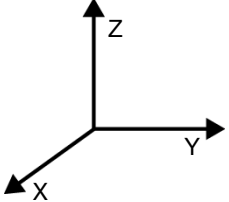
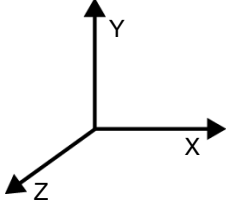
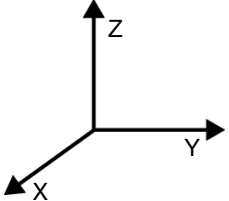
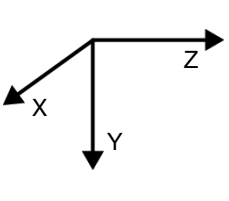
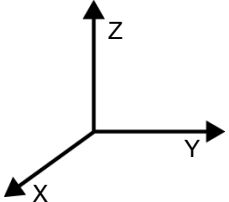
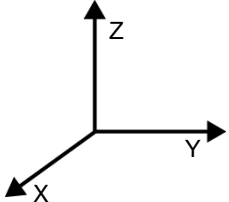
Mapping	SPAN Frame Axis	SPAN Frame	IMU Enclosure Frame Axis	IMU Enclosure Frame
1	X		Y	
	Y		Z	
	Z		X	
2	X		Z	
	Y		Y	
	Z		-X	
3	X		Z	
	Y		X	
	Z		Y	
4	X		X	
	Y		Z	
	Z		-Y	
5 (default)	X		X	
	Y		Y	
	Z		Z	

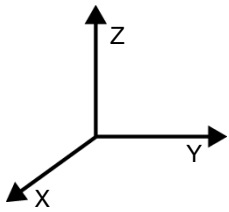
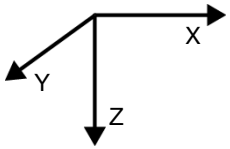
Mapping	SPAN Frame Axis	SPAN Frame	IMU Enclosure Frame Axis	IMU Enclosure Frame
6	X		Y	
	Y		X	
	Z		-Z	

3.1.3 The Enclosure Frame

The definition of the enclosure frame is defined on the SPAN-CPT and represents how the sensors are mounted in the enclosure. If the SPAN-CPT is mounted with the z-axis (as marked on the SPAN-CPT) pointing up, the enclosure frame is the same as the SPAN frame.

The origin of this frame is not the enclosure center, but the Center of Navigation (sensor center).

Figure 9: SPAN-CPT Center of Navigation

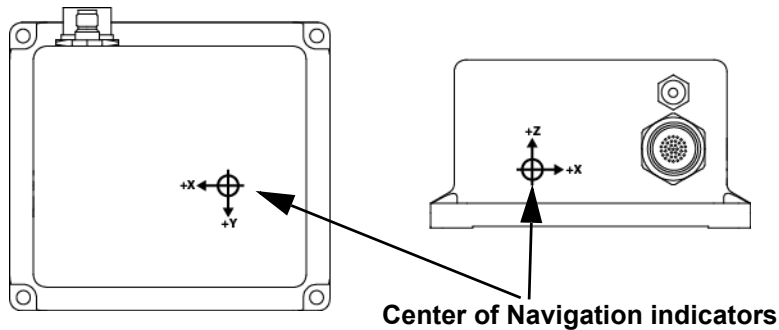

Although the SPAN-CPT is a rugged product, the gyros inside are sensitive and can be damaged by environmental shocks such as vibration, bumps and rapid temperature changes.

3.1.4 The Vehicle Frame

The definition of the vehicle frame is as follows:

- z-axis points up through the roof of the vehicle perpendicular to the ground
- y-axis points out the front of the vehicle in the direction of travel
- x-axis completes the right-handed system (out the right-hand side of the vehicle when facing forward)

Use the `VEHICLEBODYROTATION` command to enter the rotation into the system and use the `RVBCALIBRATE` command to calculate this rotation. See the [SPAN on OEM6 Firmware Reference Manual](#) for information about these commands.

Figure 10: Vehicle Frame

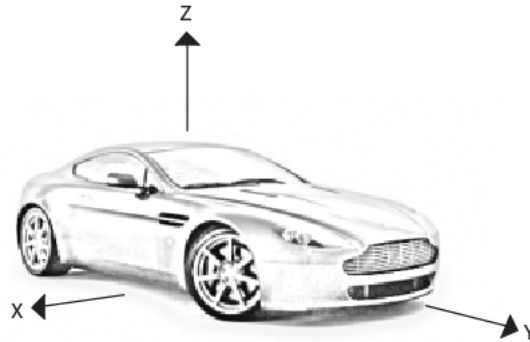

3.2 Communicating with the SPAN-CPT System

After the receiver is connected to a computer, antenna and power supply, install the NovAtel PC Utilities (NovAtel Connect and Convert). The installation instructions are in the [SPAN-CPT Quick Start Guide](#). Alternatively, use a terminal emulator program such as HyperTerminal to communicate with the receiver.) Refer also to the NovAtel Connect Help file for more details. The Help file is accessed by choosing *Help* from the main menu in NovAtel Connect or press F1 when the cursor is in a window.

3.2.1 Use NovAtel Connect to Communicate

NovAtel Connect is a Windows application that provides a Graphical User Interface (GUI) to set up and monitor the operation of the SPAN system by providing a series of windows.

Start NovAtel Connect on the computer to enable communication.

1. Launch NovAtel Connect from the **Start** menu folder specified during the installation process. The default location is Start | Programs | NovAtel OEM6 | NovAtel Connect.
2. To define a new connection, select **New Connection** from the **Device** menu. The New Connection window appears. If a connection is already defined or if connections were imported from NovAtel Connect, choose **Open Connection** and skip to step 9.

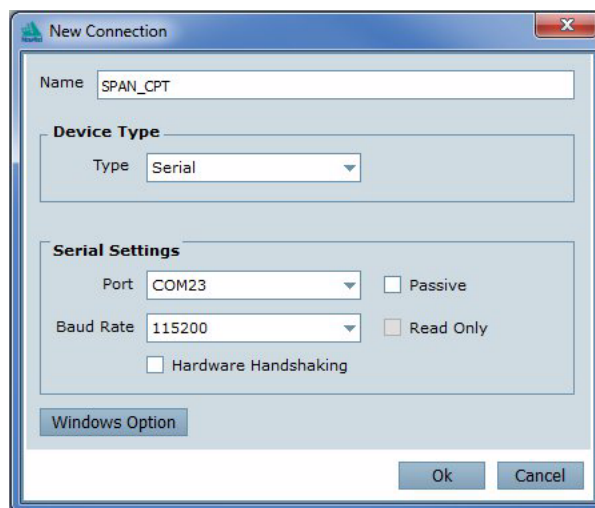

3. Enter a name for the connection.
4. Select **Serial** or **USB** from the **Type** drop down list.

5. Select the computer port the SPAN-CPT is connected to from the **Port** drop down list.
6. If you selected **Serial**, select **115200** from the **Baud Rate** drop down list.
7. If you selected **Serial**, clear the **Hardware handshaking** check box.
8. Click the **OK** button to save the new device settings.
9. Select the new configuration from the Available Device Connections area of the Open Connection window.

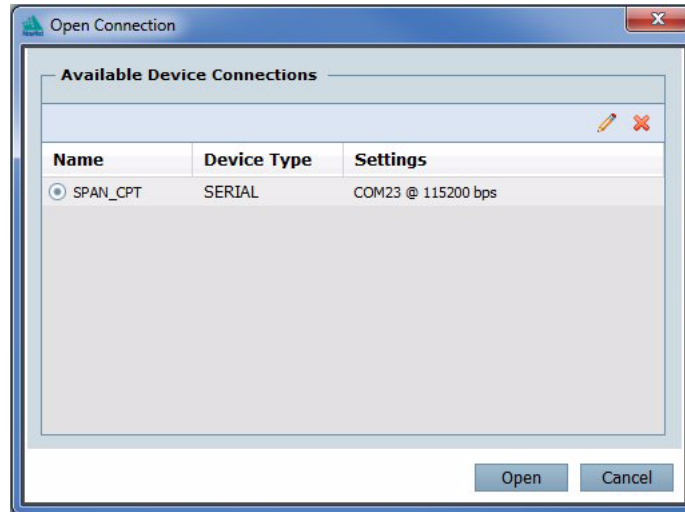

10. Click the **Open** button to open SPAN-CPT communications.
As NovAtel Connect establishes the communication session with the receiver, a progress box displays.
11. Select Tools | Logging Control from the NovAtel Connect main menu to control the receiver's logging to files and serial ports. Refer to the NovAtel Connect online Help for more information.
12. Use the Console window to enter commands.



To save the receiver configuration to Non-Volatile Memory (NVM), ensure that all windows, other than the Console window, are closed in NovAtel Connect and then use the `SAVECONFIG` command.

3.2.2 INS Window in NovAtel Connect

The INS Window in NovAtel Connect is described below. Refer to the NovAtel Connect online help for more details.

INS Window: The Position, Velocity and Attitude (roll, pitch and azimuth) sections display data from the INSPVA log along with standard deviations calculated from the INSCOV log. Information in the ZUPT (Zero Velocity Update) section reflects the current `INSZUPT` command setting. The receiver uses the X, Y and Z Offset fields to specify an offset from the IMU, for the output position and velocity of the INS solution, as specified by the `SETINSOFFSET` command or the NovAtel Connect SPAN wizard. The INS Configuration/Status section displays the IMU type, IMU Status and local date/time information. The dial is a graphical display of the Roll, Pitch and Azimuth values indicated by an arrow on each axis.

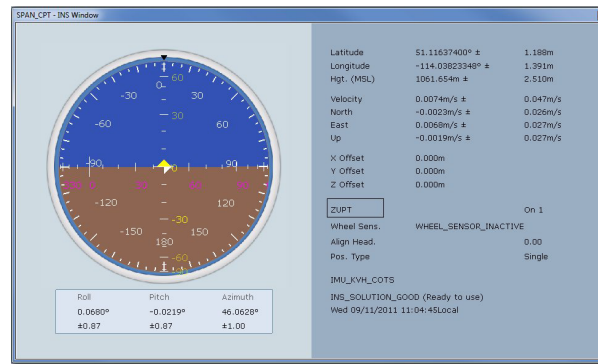

3.3 Software Configuration

3.3.1 GNSS Configuration

The GNSS configuration can be set up for different accuracy levels such as single point, SBAS, DGPS and RTK (RTCA, RTCM, RTCM V3 and CMR). The SPAN-CPT can also be set up for L-Band VBS, XP or HP. Refer to the [OEM6 Family Installation and Operation Manual](#) (OM-20000128) for details on DGPS, RTK, L-Band or SBAS setup and operation.

With no additional configuration, the system operates in single point mode.

3.3.2 SPAN IMU Configuration

You can configure the IMU portion of the SPAN system using software commands or the NovAtel Connect software utility.



A GNSS antenna must be connected and tracking satellites for operation.

3.3.2.1 SPAN-CPT Configuration with NovAtel Connect

1. Select Wizards | SPAN Alignment from the NovAtel Connect toolbar. This wizard moves through the steps required to complete an alignment and configure the receiver port to accept IMU data.



The NovAtel Connect screen shots in this manual may differ from your version of NovAtel Connect.

3.3.2.2 SPAN-CPT Configuration using Command Line

Follow these steps to enable INS as part of the SPAN system using software commands:

1. Issue the **SETIMUTOANTOFFSET** command to enter the distance from the SPAN-CPT to the GNSS antenna. See the [SPAN on OEM6 Firmware Reference Manual](#) for information about the `SETIMUTOANTOFFSET` command.

The offset between the antenna phase centre and the IMU navigation centre must remain constant and be known accurately. The X, Y and Z positive directions are clearly marked on the SPAN-CPT enclosure. The `SETIMUTOANTOFFSET` parameters are in metres:

```
SETIMUTOANTOFFSET x_offset y_offset z_offset [x_stdev] [y_stdev] [z_stdev]
```

The standard deviation fields are optional and the distances are measured from the IMU navigation center to the antenna phase center.

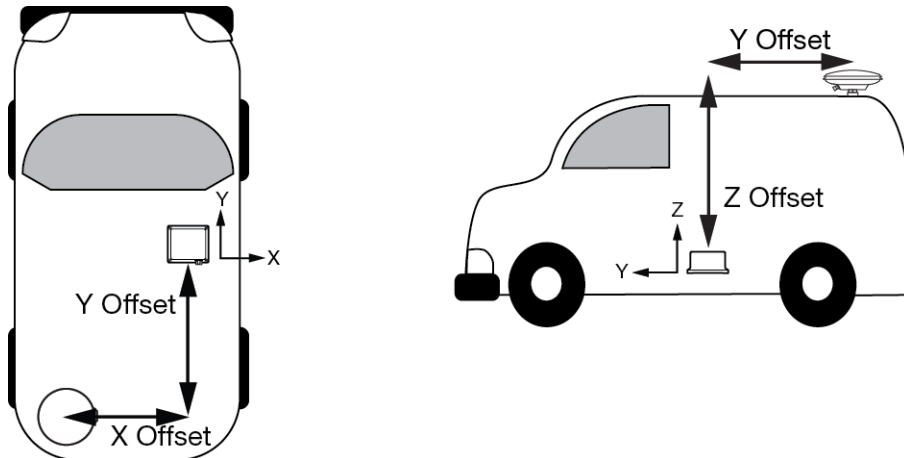

▼ This example assumes a default mounting configuration and shows an -X offset, -Y offset and +Z offset.

A typical RTK GNSS solution is accurate to a few centimetres. For the SPAN-CPT system to have this level of accuracy, the offset must be measured to within a centimetre. Any offset error between the two systems directly affects the output position. For example, a 10 cm error recording this offset will result in at least a 10 cm error in the output.

3.4 Real Time Operation

SPAN-CPT operates through the OEM6 command and log interface. Commands and logs specifically related to SPAN-CPT operation are documented in the [SPAN on OEM6 Firmware Reference Manual](#).

Real time operation notes:

- Inertial data does not start until FINESTEERING time status is reached, and therefore, the SPAN-CPT system does not function unless a GNSS antenna is connected with a clear view of the sky.
- The inertial solution is computed separately from the GNSS solution. The GNSS solution is available from the SPAN-CPT system through the GNSS specific logs even without SPAN running. The integrated GNSS/INS solution is available through special INS logs documented in the [SPAN on OEM6 Firmware Reference Manual](#).
- The IMU solution is available at the maximum rate of output of the SPAN-CPT (100 Hz). Because of this high data rate, a shorter header format was created. These shorter header logs are defined with an S (RAWIMUSB rather than RAWIMUB). We recommend using these logs instead of the standard header logs to save throughput on the COM port.

Status of the inertial solution can be monitored using the inertial status field in the INS logs, [Table 4, Inertial Solution Status](#) on page 27.

Table 4: Inertial Solution Status

Binary	ASCII	Description
0	INS_INACTIVE	IMU logs are present, but the alignment routine has not started; INS is inactive.
1	INS_ALIGNING	INS is in alignment mode.

2	INS_HIGH_VARIANCE	The INS solution is still being computed but the azimuth solution uncertainty has exceeded the threshold. The default threshold is 2 degrees. ^a The solution is still valid but you should monitor the solution uncertainty in the INSCOV log. You may encounter this state during times when the GNSS, used to aid the INS, is absent. ^b
3	INS_SOLUTION_GOOD	The INS filter is in navigation mode and the INS solution is good.
6	INS_SOLUTION_FREE	The INS filter is in navigation mode and the GNSS solution is suspected to be in error. This may be due to multipath or limited satellite visibility. The inertial filter has rejected the GNSS position and is waiting for the solution quality to improve.
7	INS_ALIGNMENT_COMPLETE	The INS filter is in navigation mode, but not enough vehicle dynamics have been experienced for the system to be within specifications.
8	DETERMINING_ORIENTATION	INS is determining the IMU axis aligned with gravity.
9	WAITING_INITIALPOS	The INS filter has determined the IMU orientation and is awaiting an initial position estimate to begin the alignment process.

- a. This value is configured using the INSTHRESHOLDS command. See the [SPAN on OEM6 Firmware Reference Manual](#) (OM-20000144) for more information.
- b. See also question #5 in *Appendix C, Frequently Asked Questions* on page 59.

3.4.1 System Start-Up and Alignment Techniques

The system requires an initial attitude estimate to start the navigation filter. This is called system alignment. On start-up the system has no position, velocity or attitude information. When the system is first powered up, the following sequence of events happens:

1. The first satellites are tracked and coarse time is solved.
2. Enough satellites are tracked to compute a position.
3. Receiver “fine time” is solved, meaning the time on board the receiver is accurate enough to begin timing IMU measurements.
4. Raw IMU measurements begin to be timed by the receiver and are available to the INS filter. They are also available in the RAWIMU, RAWIMUS, RAWIMUX, and RAWIMUSX logs. The INS Status field changes from INS_INACTIVE through DETERMINING_ORIENTATION and WAITING_INITIALPOS during this period.
5. The inertial alignment routine starts and the INS Status field reports INS_ALIGNING.
6. When the kinematic alignment is completed and the INS Status field changes to INS_ALIGNMENT_COMPLETE. The system transitions to navigation mode.
7. The solution is refined using updates from GNSS. Once the system is operating within specifications and after some vehicle movement, the INS Status field changes to INS_SOLUTION_GOOD. This indicates that the estimated azimuth standard deviation is below 2 degrees. If it increases above 2 degrees, the status changes to INS_HIGH_VARIANCE.



The azimuth standard deviation threshold can be changed using the INSTHRESHOLDS command. See the [SPAN on OEM6 Firmware Reference Manual \(OM-20000144\)](#) for information about this command.

3.4.1.1 Default Kinematic Alignment

A kinematic alignment is the default alignment routine for SPAN-CPT.

If the system is mounted as recommended with the z-axis pointing up and the y-axis aligned with the forward direction of the vehicle, then no additional configuration is required to complete a moving alignment.

Once the INS status reaches `INS_ALIGNING`, the moving alignment happens after the vehicle velocity reaches 1.15 m/s (~4 km/h). The INS status then changes to `INS_ALIGNMENT_COMPLETE`. The moving alignment transfers the GNSS course over ground pitch and azimuth to the attitude of the IMU. This alignment routine is best suited for ground vehicles where the direction of travel is coincident with the forward axis of the vehicle and the roll of the vehicle is close to zero. The fast alignment routine may not be suitable for some marine or airborne applications, where the direction of travel may be different from the forward axis of the vehicle because of factors like a crab angle.

If SPAN-CPT is installed with the IMU axes NOT aligned with the vehicle, then additional configuration is needed to complete the moving alignment. These settings can be set graphically using the INS configuration wizard in the NovAtel Connect utility or through the command interface by issuing the following commands:

1. Specify which IMU axis is most closely aligned with gravity using the `SETIMUORIENTATION` command. See the [SPAN on OEM6 Firmware Reference Manual](#) for a description of this command and *Table 3, Full Mapping Definitions* on page 21 for the number corresponding to each orientation. For example, if the z-axis of the SPAN-CPT is pointing up, send this command:

```
SETIMUORIENTATION 5
```

2. Specify the angular offset from the vehicle frame to the SPAN frame (known as the vehicle/body rotation or RVB) using the `VEHICLEBODYROTATION` command. Details of this command are in the [SPAN on OEM6 Firmware Reference Manual](#).

Following the example started above, if the SPAN-CPT is installed rotated so that the y-axis points out the right side of the vehicle instead of forward, enter this command:

```
VEHICLEBODYROTATION 0 0 -90
```



Angular rotations are difficult to visualize, so if you have complex rotations or some other axis that +Z pointing up, use the NovAtel Connect SPAN wizard for assistance with these settings.

The accuracy of the initial attitude depends on the dynamics of the vehicle and the accuracy of the angles input in the `VEHICLEBODYROTATION` command. The alignment is only an estimate of the attitude of the vehicle and as the vehicle experiences dynamics, the accuracy of the attitude solution improves. Once the attitude accuracy has converged the INS status changes to “`INS_SOLUTION_GOOD`”.

3.4.1.2 Manual Alignment

If the attitude of your vehicle (roll, pitch, azimuth) is known, enter the attitude information using the `SETINITATTITUDE` command. Details of this command are in the [SPAN on OEM6 Firmware Reference Manual](#).

3.4.1.3 Dual Antenna Alignment

SPAN can also use information available from a NovAtel Dual Antenna ALIGN[®] solution to perform an alignment. Refer to *Chapter 4, SPAN-CPT Dual-Antenna* on page 35 for details.

3.4.2 Navigation Mode

Once the alignment routine has successfully completed, SPAN enters navigation mode.

SPAN computes the solution by accumulating velocity and rotation increments from the IMU to generate position, velocity and attitude. SPAN models system errors by using a filter. The GNSS solution, phase observations and automatic zero velocity updates (ZUPTs) provide updates to the filter. Peripheral updates can also be supplied; wheel sensor for displacement updates or an external receiver for heading updates.

Following the alignment, the attitude is coarsely defined, especially in heading. Vehicle dynamics, specifically turns, stops and starts, allow the system to observe the heading error and allows the heading accuracy to converge. The amount of dynamics required for filter convergence vary by the alignment quality, IMU quality, and maneuvers performed. The INS Status field changes to `INS_SOLUTION_GOOD` once convergence is complete. If the attitude accuracy decreases, the INS Status field changes to `INS_HIGH_VARIANCE`. When the accuracy converges again, the INS status continues as `INS_SOLUTION_GOOD`.

3.4.3 Vehicle to SPAN-CPT Frame Angular Offsets Calibration Routine

Kinematic fast alignment requires the angular offset between the vehicle and the SPAN-CPT frame is known approximately. If the angles are simple (that is, a simple rotation about one axis), the values can easily be entered manually through the `VEHICLEBODYROTATION` command. If the angular offset is more complex (rotation is about 2 or 3 axis), then the calibration routine may provide a more accurate estimation of the values.

The steps for the calibration routine are:

1. Apply power to the SPAN-CPT (see *Appendix A, Technical Specifications* on page 51).
2. Configure the SPAN-CPT (see *SPAN IMU Configuration* on page 25).
3. Ensure an accurate lever arm is entered into the system.
4. Allow the system to complete an alignment (see the *System Start-Up and Alignment Techniques* on page 28).
5. Enable the vehicle to body calibration using the `RVBCALIBRATE ENABLE` command. See the [SPAN on OEM6 Firmware Reference Manual](#).
6. Start to move the system under good GNSS conditions. Movement of the system under good GNSS conditions is required for the observation of the angular offsets.

Vehicle speed must be greater than 5 m/s (18 km/hour) for the calibration to complete. Drive straight on a level surface if possible.

7. When the solved angles are verified (after approximately 30 seconds), the calibration stops and the `VEHICLEBODYROTATION` log provides the solved values. Log `VEHICLEBODYROTATION` using the `ONNEW` trigger to monitor the progress of the calibration.

The rotation parameters can be saved in NVM for use on startup in case a fast alignment is required in the future. Each time the SPAN-CPT is re-mounted, this calibration should be performed again. See *System Start-Up and Alignment Techniques* on page 28 for details on alignment.



After the `RVBCALIBRATE ENABLE` command is entered, there are no vehicle body rotation parameters present and a kinematic alignment is NOT possible. Therefore this command should only be entered after the system has performed either a static or kinematic alignment and has a valid INS solution.



The solved rotation values are used only for a rough estimate of the angular offsets between the SPAN-CPT and vehicle frames. The offsets are used when aligning the system while in motion (see *System Start-Up and Alignment Techniques* on page 28). The angular offset values are not applied to the attitude output, unless the `APPLYVEHICLEBODYROTATION` command is enabled.

3.4.4 SPAN-CPT Wheel Sensor

The SPAN-CPT system supports wheel sensor inputs, integrated via the SPAN-CPT. The SPAN-CPT accepts TTL- level input pulses from a wheel sensor through the multi-pin connector. See *Appendix A, Technical Specifications* on page 51 for specifications on the wheel sensor interface.

3.4.4.1 Wheel Sensor Update Logic

The wheel sensor information is sent to the SPAN-CPT along with the raw IMU data.

The SPAN filter uses sequential TIMEDWHEELDATA logs to compute a distance traveled between update intervals (1 Hz). This information is used to constrain free inertial drift during times of poor GNSS visibility. The filter also contains a state for modeling the circumference of the wheel as it may change due to hardware changes or environmental conditions.

The modeled wheel circumference is available in the WHEELSIZE log. Information on how the wheel sensor updates are being used is available in the INSUPDATE log.

3.5 Azimuth Sources on a SPAN System

The SPAN system use three different methods to calculate the azimuth.

- Course Over Ground
- Inertial Azimuth
- Align Azimuth

3.5.1 Course Over Ground

The course over ground azimuth is determined using the position delta between two position solutions computed by the OEM receiver. This is the simplest way to compute an azimuth and is done using either the GNSS solution or the INS solution. This method does not work when the vehicle is stationary as any position difference is due to position error and the computed azimuth is meaningless.

Course over ground azimuth is of greatest advantage in aerial or marine environments where the actual direction of travel may not match the forward axis of the aircraft/boat due to winds or currents. This effect is known as the crab angle. Course over ground azimuth is a great way to compute the offset if another means of computing the vehicle azimuth are available.

Course over ground azimuths are available in several different velocity logs. See *Table 5, Logs with Azimuth data* on page 32.

3.5.2 Inertial Azimuth

The inertial azimuth computed by the SPAN inertial navigation filter. It uses the sensors in the IMU to compute the azimuth of the IMU (this can be rotated to another reference if desired). For more information, see the `APPLYVEHICLEBODYROATION` and `VEHICLEBODYROTATION` commands in the [SPAN on OEM6 Firmware Reference Manual \(OM-20000144\)](#).

This azimuth is the one provided in the majority of the INS logs available to a SPAN user. See *Table 5, Logs with Azimuth data* on page 32.

3.5.3 ALIGN Azimuth

On SPAN systems with dual antennas, an azimuth is available from the dual antenna baseline. This is the same azimuth that is used as an update to the SPAN solution. It is noisier than the inertial azimuth and is available at a much lower rate, but will have a stable mean. This azimuth is computed from the master antenna to the rover antenna based on how the antennas are oriented on the vehicle.

There is a specific subset of logs that output this azimuth. See *Table 5, Logs with Azimuth data* on page 32.

Table 5: Logs with Azimuth data

Log	Log Format	Azimuth Source
INSPVA / INSPVAS / INSPVAX	NovAtel	Inertial
INSATT / INSATTS / INSATTX	NovAtel	Inertial
PASHR	NMEA	Inertial
INSSPD	NovAtel	Course Over Ground Computed using the INS solution only
BESTVEL	NovAtel	Course Over Ground From the best system solution which could be either GNSS or INS
GPVTG	NMEA	Course Over Ground From the best system solution which could be either GNSS or INS
HEADING	NovAtel	ALIGN
GPHDT	NMEA	ALIGN

3.6 Data Collection

The INS solution is available in the INS specific logs with either a standard or short header. Other parameters are available in the logs shown in *Table 6, Solution Parameters*:

Table 6: Solution Parameters

Parameter	Log	
Position	INSPOS or INSPOSS INSPVA or INSPVAS	INSPOSX or INSPVAX ^a
Velocity	INSVEL or INSVELS INSSPD or INSSPDS INSPVA or INSPVAS	INSVELX or INSPVAX ^a
Attitude	INSATT or INSATTS INSPVA or INSPVAS	INSATTX or INSPVAX ^a
Solution Uncertainty	INSCOV or INSCOVs	

- a. These logs contain variance information and are therefore large logs.
Use a low logging rate (<20 Hz) only.

The position, velocity and attitude are available together in the INSPVA and INSPVAS logs.

The inertial solution is available up to a rate of 100 Hz. Data can be requested at a specific rate up to the maximum IMU output rate or can be triggered by the mark input trigger at rates up to 20 Hz.

The GNSS-only solution is still available through the GNSS-only logs such as RTKPOS, PSRPOS and OMNIHPPOS. When running SPAN-CPT, rates of non-INS logs should be limited to a maximum rate of 5 Hz. Refer to the [OEM6 Family Firmware Reference Manual](#) for more details on these logs. INS-only data logging and output can be at rates of up to the rate of the IMU data.



The highest rate to request GNSS logs (RANGE, BESTPOS, RTKPOS, PSRPOS and so on) while in INS operation is 5 Hz. If the receiver is not running INS, GNSS logs can be requested at rates up to 20 Hz.



Ensure all windows, other than the Console, are closed in NovAtel Connect before using the `SAVECONFIG` command to save settings in NVM. Otherwise, unnecessary data logging occurs and may overload the system.

Specific logs need to be collected for post-processing (see *Data Collection for Post-Processing* on page 33).

To store data from a SPAN-CPT, connect a computer. The computer should be equipped with a data storage device such as a Compact Flash Card, CD or USB stick.



Logging Restriction

Logging excessive amounts of high rate data can overload the system. When configuring the output for SPAN, NovAtel recommends that only one high rate (>50 Hz) message be configured for output at a time. It is possible to log more than one message at high rates, but doing so could have negative impacts on the system. Also, if logging 100/200 Hz data, always use the binary format and, if possible, the short header binary format (available on most INS logs).

For optimal performance, log only one high rate output at a time. These logs could be:

- Raw data for post processing
RAWIMUXSB ONNEW (100 or 200 Hz depending on IMU)
 - RAWIMU logs are not valid with the ONTIME trigger. The raw IMU observations contained in these logs are sequential changes in velocity and rotation. As such, you can only use them for navigation if they are logged at their full rate. See details of these logs in the [SPAN on OEM6 Firmware Reference Manual](#).
- Real time INS solution
INSPVASB ONTIME 0.01 or 0.005 (maximum rate equals the IMU rate)
 - Other possible INS solution logs available at high rates are: INSPOSSB, INSVELSB and INSATTSB

3.7 Data Collection for Post-Processing

Some operations such as aerial measurement systems do not require real time information from SPAN-CPT. These operations are able to generate the position, velocity or attitude solution post-mission in order to generate a more robust and accurate solution than is possible in real time.

In order to generate a solution in post-processing, data must be simultaneously collected at a base station and each rover. The following logs must be collected in order to successfully post-process data:

From a base:

- RANGECMPB ONTIME 1
- RAWEPHEMB ONCHANGED
- GLOEPHEMERISB ONCHANGED (if using GLONASS)

From a rover:

- RANGECMPB ONTIME 1
- RAWEPHEMB ONCHANGED
- GLOEPHEMERISB ONCHANGED (if using GLONASS)
- RAWIMUSXB ONNEW
- IMUTOANTOFFSETSB ONCHANGED
- VEHICLEBODYROTATIONB ONCHANGED

Post-processing is performed through the Waypoint Inertial Explorer[®] software package available from the NovAtel Waypoint Products Group. Visit our Web site at www.novatel.com/products/software/waypoint-products/ for details.



The highest rate to request GNSS logs (RANGE, BESTPOS, RTKPOS, PSRPOS and so on) while in INS operation is 5 Hz. If the receiver is not running INS, GNSS logs can be requested at rates up to 20 Hz.

3.8 Variable Lever Arm

The variable lever arm concept arose to support applications in which the IMU is no longer rigidly fixed to the vehicle, but rather on a gimbaled mount. This creates an issue where the input lever arm offsets to the GNSS antenna are no longer correct, because the IMU can rotate on its mount, while the antenna remains fixed.

The use of the variable lever arm functionality requires that the device to which the IMU is attached be able to send its gimbal rotation angles back to SPAN. These angles are used to re-calculate the lever arm at the rate that they are received. SPAN is also able to output a gimbaled solution at the rate the gimbal angles are received. Refer to [SPAN on OEM6 Firmware Reference Manual](#) for details.

NovAtel's ALIGN® heading technology generates distance and bearing information between a “master” and one or more “rover” receivers. This feature is ideal for those wanting relative directional heading, separation heading between two objects or heading information with moving base and pointing applications. Heading applications can be applied over various markets, including machine control, unmanned vehicles, marine and agricultural markets.

SPAN-CPT dual-antenna provides the hardware necessary to run an ALIGN baseline with a SPAN-CPT and a second receiver. From any of the SPAN-CPT COM ports, the ALIGN baseline solution can be logged along with the standard OEM6 logs.



SPAN-CPT dual-antenna operation requires the dedicated use of the COM2 port for communication between receivers.

With the SPAN-CPT, the ALIGN GNSS baseline can be used to assist the initial alignment of the SPAN solution. In addition, the ALIGN baseline solution aids the heading solution from the SPAN-CPT if the heading drifts due to slow or constant dynamics.

ALIGN is capable of a 10 Hz heading output rate when integrated with SPAN-CPT.

4.1 Installation

The hardware for SPAN-CPT is installed in a manner similar to other SPAN systems. Some points to consider during installation are:

1. Install the SPAN-CPT and the two antennas in the vehicle such that the relative distance between them is fixed.
2. The antennas should be mounted where the view of the satellites are not obstructed by any part of the vehicle. As heading accuracy is dependent on baseline length, mount the antennas as far apart as possible. A minimum separation distance of 1 metre is recommended.
3. The lever arms or distance from the SPAN-CPT to the antennas needs to be fixed and accurately measured using the coordinate axes defined on the outside of the SPAN-CPT. The baseline between the two antennas does NOT need to be aligned with the vehicle axes or with the axes of the SPAN-CPT.
4. Both receivers need to be powered and connected to each other via COM2 before sending any configuration commands. It does not matter which receiver is powered on first or how long they are both powered before sending commands.

The SPAN-CPT and the FlexPak6 need to be set up as shown in the example in *Figure 11, SPAN-CPT - Dual Antenna Installation* on page 36:

Figure 11: SPAN-CPT - Dual Antenna Installation

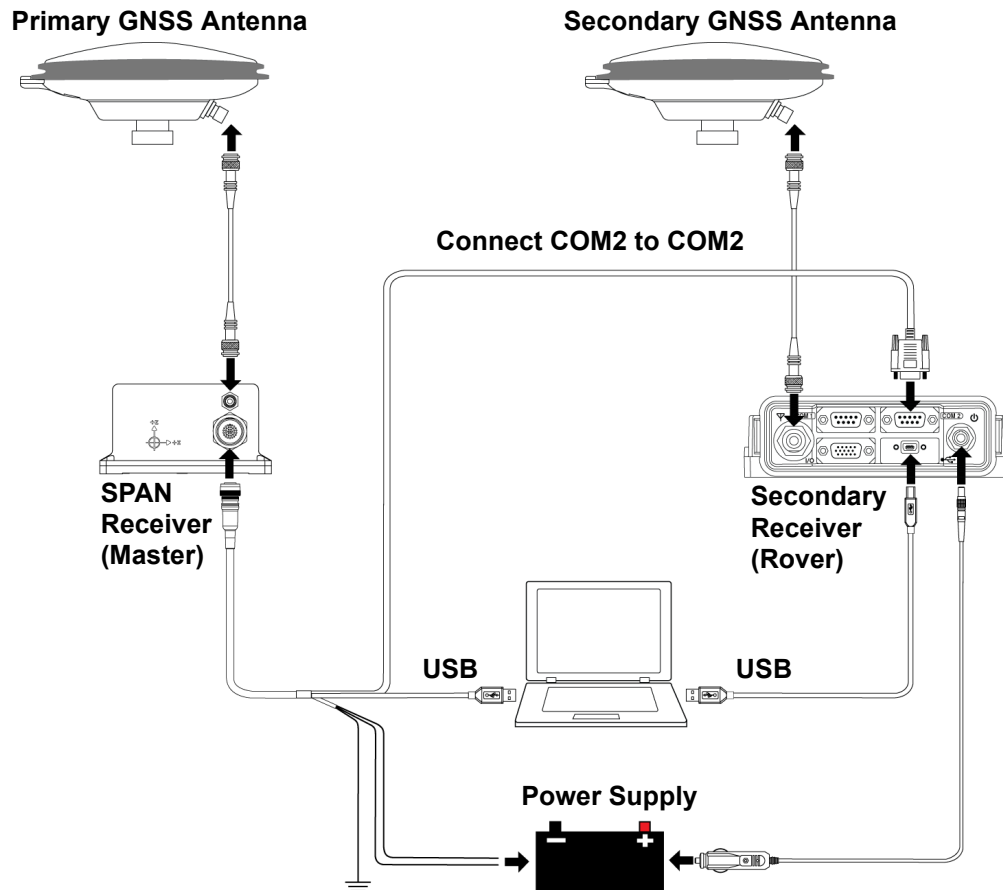

4.2 Configuring ALIGN with SPAN-CPT

Before configuring the ALIGN solution, the two receivers MUST both be powered on and connected directly between COM 2 of the SPAN receiver and COM 2 of the second receiver through either a null modem cable or an appropriate radio connection.



The rover receiver must be an ALIGN-capable model, such as D2S-Z00-000, running the latest OEM6 firmware version.

To enable the dual-antenna ALIGN solution to aid the INS alignment and provide heading updates, the offset between the antennas and the IMU must be known. This is achieved by entering lever arms to both antennas, using the SETIMUTOANTOFFSET and SETIMUTOANTOFFSET2 commands.

To configure SPAN with ALIGN Aiding:

1. Enter the lever arm from the IMU to the primary antenna (primary antenna is connected to the SPAN receiver) using the SETIMUTOANTOFFSET command.

Abbreviated ASCII example:

```
SETIMUTOANTOFFSET 0.54 0.32 1.20 0.03 0.03 0.05
```

2. Enter the lever arm from the IMU to the secondary antenna (secondary antenna is connected to the second receiver) using the SETIMUTOANTOFFSET2 command.

Abbreviated ASCII example:

```
SETIMUTOANTOFFSET2 0.54 2.32 1.20 0.03 0.03 0.05
```

Alternately, the angular offset between the dual-antenna baseline (from primary GNSS antenna to secondary GNSS antenna) and the IMU frame forward axis is entered directly via the `EXTHDGOFFSET` command.



We recommend entering the lever arms rather than entering the angular offset as this is easier to measure and will lead to better overall accuracy.

Refer to the [SPAN on OEM6 Firmware Reference Manual \(OM-20000144\)](#) for the syntax of the above commands.

As with all ALIGN-capable products, the GNSS baseline solution is available from the GPHDT and HEADING logs. For INS heading, please use INSATT or INSPVA.

The SPAN system can be configured for different alignment routines depending on the motion conditions experienced during the alignment period. For example, in marine applications, the dynamics required for either a coarse or kinematic alignment cannot be guaranteed, so a different alignment routine is required.

The different alignment routines are described in the following sections:

4.3 Configuring SPAN with ALIGN on SPAN-CPT

To enable the dual-antenna ALIGN solution to aid the INS alignment and provide heading updates, the offset between the antennas and the SPAN-CPT must be known. This is achieved by entering lever arms to both antennas, using the `SETIMUTOANTOFFSET` and `SETIMUTOANTOFFSET2` commands.

To configure SPAN with ALIGN aiding:

1. Enter the lever arm from the SPAN-CPT to the primary antenna (primary antenna is connected to the SPAN-CPT) using the `SETIMUTOANTOFFSET` command.

Abbreviated ASCII example:

```
SETIMUTOANTOFFSET 0.54 0.32 1.20 0.03 0.03 0.05
```

2. Enter the lever arm from the SPAN-CPT to the secondary antenna (secondary antenna is connected to the OEM6 receiver) using the `SETIMUTOANTOFFSET2` command.

Abbreviated ASCII example:

```
SETIMUTOANTOFFSET2 0.54 2.32 1.20 0.03 0.03 0.05
```

The SPAN-CPT can be configured for different alignment routines depending on the motion conditions experienced during the alignment period. For example, in marine applications, the dynamics required for the default kinematic alignment cannot be guaranteed, so a different alignment routine is required.

The different alignment routines are described in the following sections.

4.3.1 Alignment on a Moving Vessel - Aided Transfer Alignment

This alignment routine is the preferred dual antenna alignment method. It is used if the alignment mode is set to `AIDED_TRANSFER` using the `ALIGNMENTMODE` command, and can be used if the alignment mode is set to `AUTOMATIC`.

If your vehicle is not stationary during the alignment, such as may be the case on a ship, use the Aided Transfer Alignment routine. This alignment method uses the ALIGN baseline solution to perform an instantaneous alignment of the vehicle attitude.

The alignment happens instantaneously after the receiver establishes communication with the IMU and computes a verified, fixed integer, ALIGN solution. The INS status changes to `INS_ALIGNMENT_COMPLETE` or `INS_SOLUTION_GOOD`, depending on the variances of the ALIGN solution, and the measured lever arm/external heading offset.

To guarantee the use of this alignment mode, the configuration command `ALIGNMENTMODE` must be sent to the receiver:

```
ALIGNMENTMODE AIDED_TRANSFER
```

4.3.2 Alignment on a Stationary Vehicle - Aided Static Alignment

An alternative to the aided transfer alignment, the ALIGN heading can be used as a seed for a coarse static alignment. In this mode, the standard coarse alignment routine runs given the initial azimuth value. As with the transfer alignment, the first verified fixed RTK solution is used to provide the alignment seed after which the coarse alignment (`INS_ALIGNING`) begins. After the coarse alignment is complete, the INS status changes to `INS_ALIGNMENT_COMPLETE`. After the attitude accuracy has converged, the INS status changes to `INS_SOLUTION_GOOD`. This alignment mode is useful if the initial vehicle roll is more than 20 degrees.

To use this alignment mode, the configuration command `ALIGNMENTMODE` must be sent to the receiver.

```
ALIGNMENTMODE AIDED_STATIC
```

4.3.3 Unaided Alignment

The unaided alignment sets the SPAN system to use only single antenna alignment options (static, kinematic or manual alignment).

To use this alignment mode, the configuration command `ALIGNMENTMODE` must be sent to the receiver.

```
ALIGNMENTMODE UNAIDED
```

4.3.4 Automatic Alignment Mode - Automatic Alignment (default)

Automatic Alignment Mode Selection is the default setting for a SPAN receiver. This mode is designed to allow alignment of the system as quickly as possible, using either an aided transfer alignment (*Alignment on a Moving Vessel - Aided Transfer Alignment* on page 37); a kinematic alignment (*Default Kinematic Alignment* on page 29); or a manual alignment (*Manual Alignment* on page 29).

The first available technique will be used, regardless of its relative quality. If you wish to guarantee a specific technique is used, or use an aided static alignment, you must select the desired alignment mode manually. No additional configuration is required to use this alignment routine.

4.4 SPAN ALIGN Attitude Updates

The INS heading updates are used to help constrain the azimuth drift of the INS solution whenever possible. This is of the greatest value with lower-quality IMUs and in environments with low dynamics where the attitude error is less observable. Slow moving marine or train applications are good examples of the intended use. By providing an external heading source, the solution drift can be constrained in these environments.

You can monitor the heading update status as outlined in the `INSUPDATE` command in the [SPAN on OEM6 Firmware Reference Manual \(OM-20000144\)](#).

Download the most recent versions of the NovAtel firmware and receiver software from the NovAtel website at [www.novatel.com Support/Firmware/Software and Manuals](http://www.novatel.com/Support/Firmware/Software%20and%20Manuals).

OEM6 Firmware and Software



Refer to *Transferring Firmware Files on page 44* for descriptions of the Update and OEM versions.

NovAtel Connect PC Utilities Software Bundle

Bundled PC Utilities software includes:

- NovAtel Connect (a GUI interface)
- Connection Import (imports connection profiles)
- Convert (converts receiver data logs into different formats)
- USB Drivers and Window Signing



Refer to the PC Utilities manual on the CD provided with the product and the NovAtel Connect online help for use instructions.

Firmware and Software included

- SoftLoad firmware
- WinLoad software utility



WinLoad and SoftLoad instructions follow.

5.1 Firmware Updates and Model Upgrades

A local NovAtel dealer can provide all the information needed to upgrade or update a receiver. Refer to www.novatel.com/where-to-buy for contact information or contact sales@novatel.com or support@novatel.com directly.

5.1.1 Firmware Updates

Firmware updates are firmware releases that include fixes and enhancements to the receiver functionality. Firmware updates are released occasionally on the NovAtel web site as they become available. New firmware must be loaded into the receiver through one of the COM ports. Once loaded, the receiver reboots and begins operating with the new firmware.



Direct access to a serial COM port on the SPAN-CPT is required.

5.1.2 **Model Upgrades**

Model upgrades enable purchased receiver features.

Contact a local NovAtel dealer to assist in selecting the upgrade options that best suit your GNSS needs at www.novatel.com/where-to-buy. Contact NovAtel Customer Support www.novatel.com/support or [NovAtel Sales](#) to request a temporary upgrade authorization code for trial purposes.

The receiver stores the firmware in Non-Volatile Memory (NVM), which allows model upgrades to be performed without returning the receiver to the dealer. Model upgrades can be applied to the receiver with an authorization code and the `AUTH` command.

5.2 Authorization Code

An authorization code, commonly known as an auth-code, is required to upgrade and possibly update a SPAN-CPT. Auth-codes are obtained by contacting [NovAtel Customer Support](#). Upon contact, NovAtel Customer Support requires:

- the receiver model number
- the receiver serial number
- the receiver firmware version

Enter the `LOG VERSION` command to determine the receiver model, serial number and firmware version.

Example:

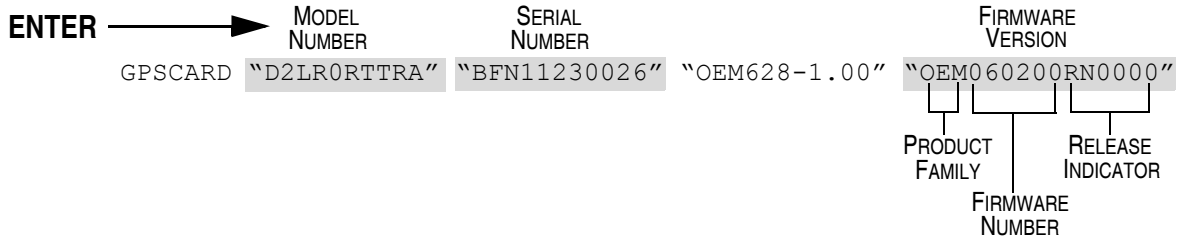

After determining the appropriate model and firmware version the authorization code (auth-code) is issued. The auth-code is required to unlock the features on the new model type.

To upgrade to a new model with the same firmware version, use the `AUTH` command with the issued auth-code (if required), as outlined in *Updating or Upgrading Using the WinLoad Utility* on page 44.

To upgrade to a new model with a higher firmware version, the new firmware .HEX file needs to be loaded into the receiver using the WinLoad utility program. WinLoad and the firmware .HEX files can be found at www.novatel.com/Support/Firmware/Software and Manuals/Product Updates. Refer to *Updating or Upgrading Using the WinLoad Utility* on page 44 for use instructions.

Firmware version OEM060200RN0000 (also known as firmware version 6.200) and later contain the Firmware Signature feature. This firmware feature removes the authorization code dependency on the firmware version and eliminates the need to obtain an auth-code when downloading the latest version of signed firmware.

If updating from a version before 6.200 to a signed 6.200 version, an authorization code is required. Auth-codes not required when loading signed firmware.

In version OEM060200RN0000, the receiver serial number and the software model are built into the signature in the firmware file. Once the 6.200 signed firmware is installed with a signature auth-code, future firmware updates no longer require a new unique auth-code.

The procedure for loading firmware is the same. Refer to *Upgrading Using the AUTH Command* on page 49.

The Firmware Signature feature simplifies the process of obtaining the latest releases by eliminating the need to obtain an authorization code.

An authorization code is still required if the software model changes for temporary trial upgrades or purchased permanent upgrades.

The new download package includes a signed firmware file type that uses an extension designated as ".shex" (example OEM060200RN0000.shex), as well as the latest Winload utility and What's New file containing firmware update change details.



Prior to firmware version OEM060200RN0000, authorization codes depended on the software model, the firmware version and the serial number of the receiver. The authorization code changed if any of the three items changed. The NovAtel firmware download page contains two firmware versions:

- OEM Version - contains firmware .hex file and the loading utility
- Update Version - contains firmware .hex and .shex files and the loading utility—does not require the user to manually input the authorization code

5.3 Updating or Upgrading Using the WinLoad Utility

WinLoad is the simplest and most common way to update or upgrade a receiver.

5.3.1 Transferring Firmware Files

To proceed with an update or possibly an upgrade, obtain the latest version of firmware from the NovAtel website at www.novatel.com/support/firmware-software-and-manuals.

Types of Firmware Files

The firmware update or upgrade file is one of two types:

- **Update Version (UPDT)** - The update version includes the authorization codes for all OEM6 receivers and receiver model upgrades purchased before the cut-off date². The update version is named UPDTXXXX.EXE, where XXXX is the firmware version. If the receiver or model upgrade was purchased after the cut-off date, the authorization code does not appear in the UPDT file and the OEM version must be used.
- **OEM Version** - Use the OEM version if the receiver or model upgrade was purchased after the cut-off date. When the OEM version is used, NovAtel Customer Service must generate and provide the required authorization code. Authorization codes are obtained by contacting support@novatel.com or at www.novatel.com/Support/.

The OEM version is named OEMXXXX.EXE, where XXXX is the firmware version.

For convenience, copy the update file to a GNSS sub-directory (for example, C:\GNSS\LOADER).

If the firmware update file is password protected, NovAtel Customer Support provides the required password. After copying the file to a computer, perform the following steps to extract the files:

Syntax: [filename] [password] (if required)

where filename is the name of the compressed file (but not including the .EXE extension) and password if the password is required for extraction.

Example: OEM060000RN0000.hex

In the above example, a window appears asking for a password.

The self-extracting archive produces the following files:

winload.exe	WinLoad utility program
howto.txt	Instructions on how to use the WinLoad utility
whatsnew.rtf	Information on the changes made in the firmware since the last revision
x..x.hex	Firmware version upgrade file, where x..x defines the product name and release (e.g., OEM060000RN0000.hex)

The files are extracted to unzip/program files/NovAtel Inc/x.xxx Full Update Disk, where x.xxx is the firmware version.



NovAtel has an online video tutorial that explains firmware uploading at [www.novatel.com/Support/Knowledge and Learning](http://www.novatel.com/Support/Knowledge%20and%20Learning).

5.3.2 Using the WinLoad Utility

If opening WinLoad for the first time, ensure the file and communications settings are correct.

2. For further information and the exact cut-off date, refer to the NovAtel website at [www.novatel.com/Support/Firmware/Software and Manuals/Product Updates/OEM6 Family](http://www.novatel.com/Support/Firmware/Software%20and%20Manuals/Product%20Updates/OEM6%20Family) at the bottom of the page.

Open a File to Download

Select File | Open. Navigate to the file to open (*Figure 12, WinLoad's Open Window*).

Figure 12: WinLoad's Open Window

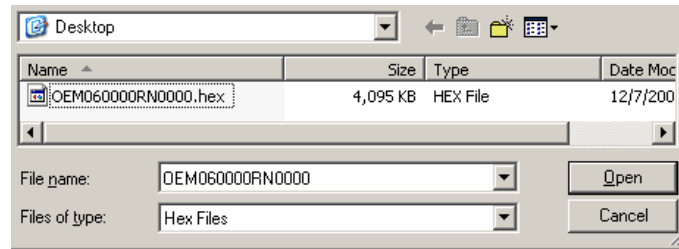

When a file is selected, the filename appears in the main WinLoad display area and in the title bar (*Figure 13, Open File in WinLoad*).

Figure 13: Open File in WinLoad

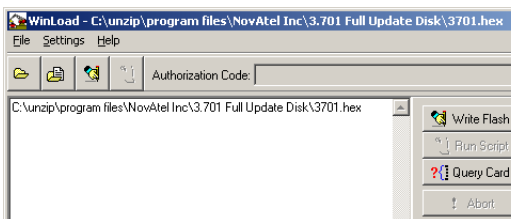

Communications Settings

To set the communications port and baud rate, select Settings | COM Settings. Choose the computer port to use from the Com Port drop down list and the baud rate from the Download Baudrate drop down list. Set the baud rate as high as possible (the default of 115200 and is preferred).

Figure 14: COM Port Setup

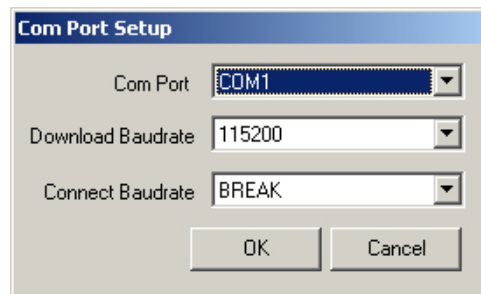

Downloading Firmware

1. Select the file to download according to *Open a File to Download on page 45*.
2. Ensure the file path and name are displayed in main display area (see *Figure 13, Open File in WinLoad on page 45*).
3. Click **Write Flash** to download the firmware.
4. When Searching for card appears in the main display, power cycle the receiver.

Figure 15: Searching for Card

5. If the Authorization Code window appears, enter the auth-code and click **OK**. See *Authorization Code* on page 42 for further information about the Authorization Code.

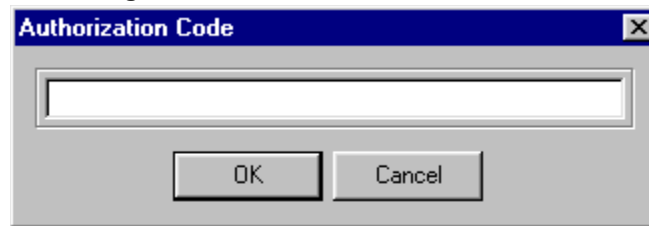
Figure 16: Authorization Code Window

6. The receiver finishes the download and then resets. The process is complete when `Done` appears in the main display area.

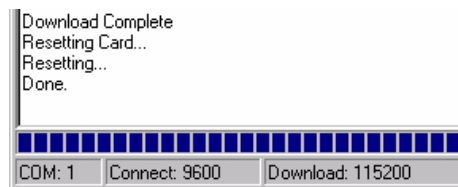
Figure 17: Upgrade Process Complete

7. Close WinLoad.

5.4 Updating using SoftLoad Commands

Use SoftLoad to update an OEM6 family receiver.



Use SoftLoad if automated loading is required or the platform used to communicate with the receiver is not supported by WinLoad.



Refer to *Types of Firmware Files* on page 44 for details on **updating** versus **upgrading**.

1. Open a connection to any port on the receiver (COM or USB port) with a user Application Programming Interface (API).
2. Request the SOFTLOADSTATUSA log using the following command:
LOG SOFTLOADSTATUSA ONCHANGED.
3. Initialize SoftLoad with a SOFTLOADRESET command. This command stops all tracking on the receiver to ensure sufficient memory is available for the loading process. A RXSTATUSEVENTA log reports a SoftLoad In Progress status.
4. Open the *.HEX firmware file or *.SHEX firmware file. *.SHEX files are treated in the same way as *.HEX files.
5. Send each line of the *.HEX or *.SHEX file to the receiver in a SOFTLOADSREC command. The S-Records must be enclosed by quotation marks:
SOFTLOADSREC "<S-RECORD>"
6. Send the SOFTLOADCOMMIT command.
7. During the loading process, SOFTLOADSTATUSA logs report the load status. Wait for the SOFTLOADSTATUSA to indicate loading is COMPLETE.
8. If using standard auth-codes (do not require a firmware signature), send the new auth-code for the receiver with the following special case of the AUTH command:
AUTH ADD_DOWNLOAD <auth-code>



Signature auth-codes are maintained internally by the receiver and do not need to be re-entered. Refer to *Authorization Code* on page 42 for details on obtaining any auth-code.

9. Reset the receiver by entering RESET, FRESET or power cycling.
10. Once the receiver resets, the new version of firmware is active.



The SoftLoad process can be cancelled safely at any time during the process using the RESET command.

5.4.1 Working with S-Records

- Records beginning with S0, S5 and S7 should be passed to the receiver directly using the `SOFTLOADSREC` command. These records contain meta data about the firmware image.
- Records beginning with S3 form the actual firmware image and can be converted to `SOFTLOADDATA` binary commands. Aside from the header, each pair of characters forms the ASCII representation of binary byte. The format is as follows:

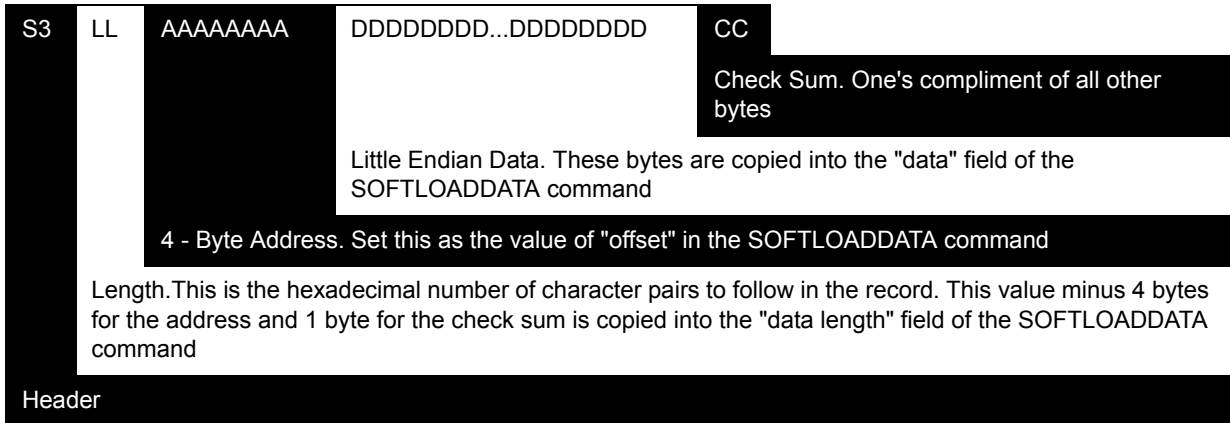

- Multiple S3 records can be packaged into a single `SOFTLOADDATA` command as long as the data from one S3 record follows immediately after the previous record, up to a maximum of 4096 bytes of data. That is, the address must equal the previous address plus the previous data length. The "offset" field remains the address of the first S3 record and the "data" and "data length" are updated to include the new data.
- The hex file data may contain many gaps and jumps. For example, in most NovAtel hex files data for address `0x000_00000` is stored near the very end of the file.

5.5 Upgrading Using the AUTH Command

The `AUTH` command authorizes the enabling (unlocking) of model features. The `AUTH` command is used to upgrade a new OEM6 family model, available with the same firmware version as the current model. This command only functions with a valid auth-code assigned by [NovAtel Customer Support](#).

The upgrade can be performed directly through the NovAtel Connect command line or from any other communications program.



Refer to *Types of Firmware Files* on page 44 for details on **updating** versus **upgrading**.

5.5.1 Upgrade Procedure

1. Power up the receiver and establish communications (refer to the *SPAN-CPT Quick Start Guide* for instructions).
2. Issue the `LOG VERSION` command to verify the current model, firmware version and serial number (refer to *Authorization Code* on page 42 for instructions on obtaining).
3. Issue the `AUTH` command, followed by the auth-code and model type (refer to *Authorization Code* on page 42 for details on obtaining any auth-code). The syntax is as follows:

```
auth <your auth-code here>
```

where `auth` is a command that enables model upgrades and `auth-code` is the upgrade authorization code, expressed as follows:

```
XXXXXXXX,XXXXXXXX,XXXXXXXX,XXXXXXXX,XXXXXXXX,MODEL,EXPDATE
```

where:

- Each X character is a case-insensitive ASCII character.
- The MODEL string is a maximum of 15 characters long and represents the model enabled by the auth-code.
- The EXPDATE string is the auth-code's expiry date, in YYMMDD format

Example:

```
auth 7WBMBK,887CB6,K5J3FH,5DF5P2,42PW8G,D1SB0GTT0,121211
```

When the `AUTH` command is executed, the receiver reboots. Issuing the `LOG VERSION` command confirms the new upgrade model type and firmware version number.

If communicating using NovAtel Connect, the communication path must be closed and reopened using the Device menu.

5.6 Key Firmware Commands

Refer to the for [OEM6 Family Firmware Reference Manual](#) for the details of these commands.

auth

log Version

reset

softloadsrec

This appendix details the technical specifications of the SPAN-CPT.

A.1 SPAN-CPT Technical Specifications

Table 7: Hardware Specification for SPAN-CPT

PHYSICAL	
SPAN-CPT Enclosure Size	152.0 mm L X 168.0 mm W X 89.0 mm H
SPAN-CPT Weight	2.28 kg
CONNECTORS	
Power and I/O	MIL-DTL-38999 Series 3
RF Antenna Connector	TNC Female

Table 8: KVH IMU Sensor Specifications

PERFORMANCE - FIBER OPTIC GYROS		
Bias Offset	± 20	°/hr
Turn On To Turn On Bias Repeatability (Compensated)	± 3	°/hr
In Run Bias Variation, At Constant Temperature	1	°/hr @ 1σ
Scale Factor Error (Total)	1500	ppm, 1σ
Scale Factor Linearity	1000	ppm, 1σ
Temperature Dependent SF Variation	500	ppm, 1σ
Angular Random Walk	0.0667	°/√hr @ 1σ
Max Input	± 375	°/sec
PERFORMANCE - ACCELEROMETERS		
Bias Offset	± 50	mg
Turn On To Turn On Bias Repeatability	± 0.75	mg
In Run Bias Variation, At Constant Temperature	0.25	mg @ 1σ
Temperature Dependent Bias Variation	0.5	mg/°C @ 1σ
Scale Factor Error (Total)	4000	ppm, 1σ
Temperature Dependent SF Variation	1000	ppm, 1σ
Accel Noise	55	μg/√Hz @ 1σ
Bandwidth	50	Hz
Max Input	±10	g

Table 9: Electrical and Environmental Specifications

<i>ELECTRICAL</i>	
Input Power	9 - 18 VDC
Power consumption	16 W (Max)
Start Up Time (Valid Data)	<5 secs
<i>ENVIRONMENTAL</i>	
Temperature, operational	-40°C to +65°C
Temperature, non-operational	-50°C to +80°C
Vibration, operational	6 g rms, 20 Hz - 2 KHz
Vibration, non-operational	8 g rms, 20 Hz - 2 KHz
Shock, operational	7g 6-10 msec, 1/2 sine
Shock, non-operational	60 g 6-10 msec, 1/2 sine
Altitude	-1000 to 50,000 ft
Humidity	95% at 35°C, 48 hrs
MTBF	≥ 10,500 hours

Table 10: Power Specifications

<i>POWER</i>	
Vin Ripple	0.5 V pk-pk Max
I in-rush	5 A maximum for duration; no longer than 4.5 ms @12 V
I steady-state	1.2 A typical @ 12 V
Chassis GND (pin-37)	connect to system chassis
Voltage	should rise monotonically to nominal level within 10 ms
Odometer Power	9 to 18 VDC @ 0-100 mA (output from Pin 13 and Pin 14)

A.2 SPAN-CPT Mechanical Drawings

Figure 18: SPAN-CPT Side and Perspective View

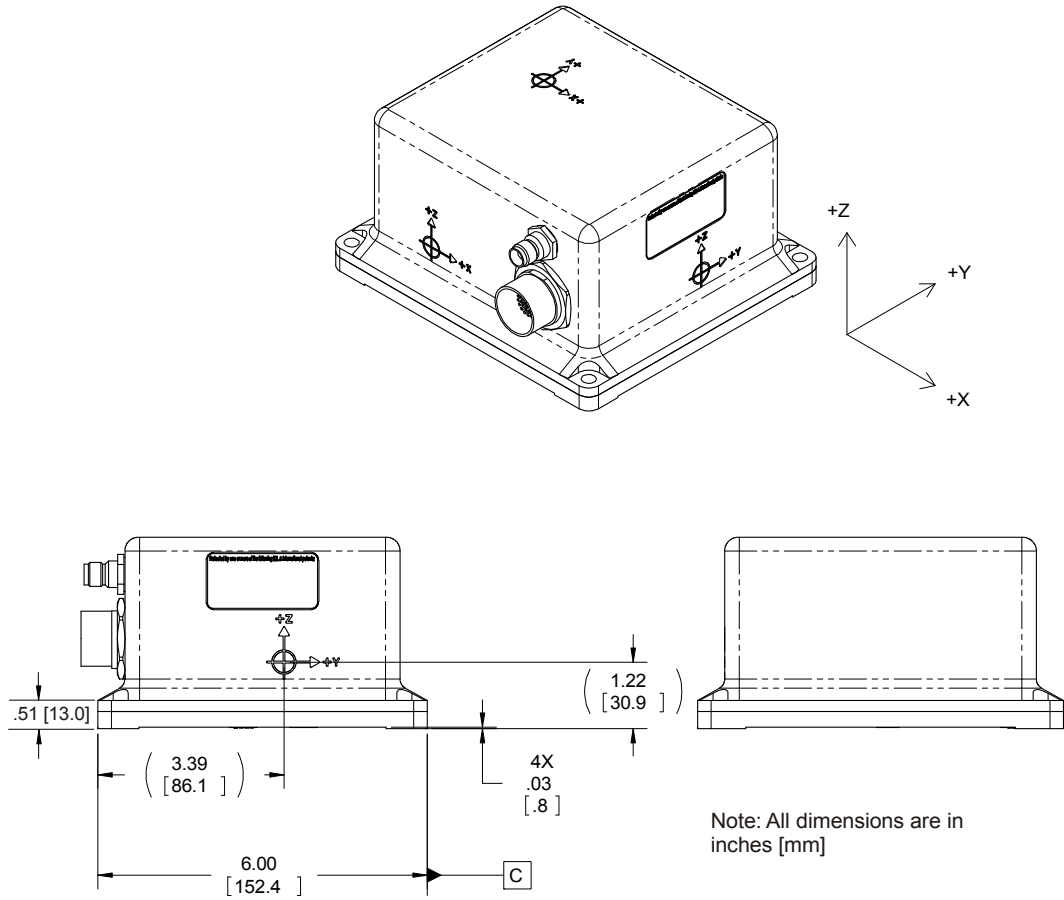
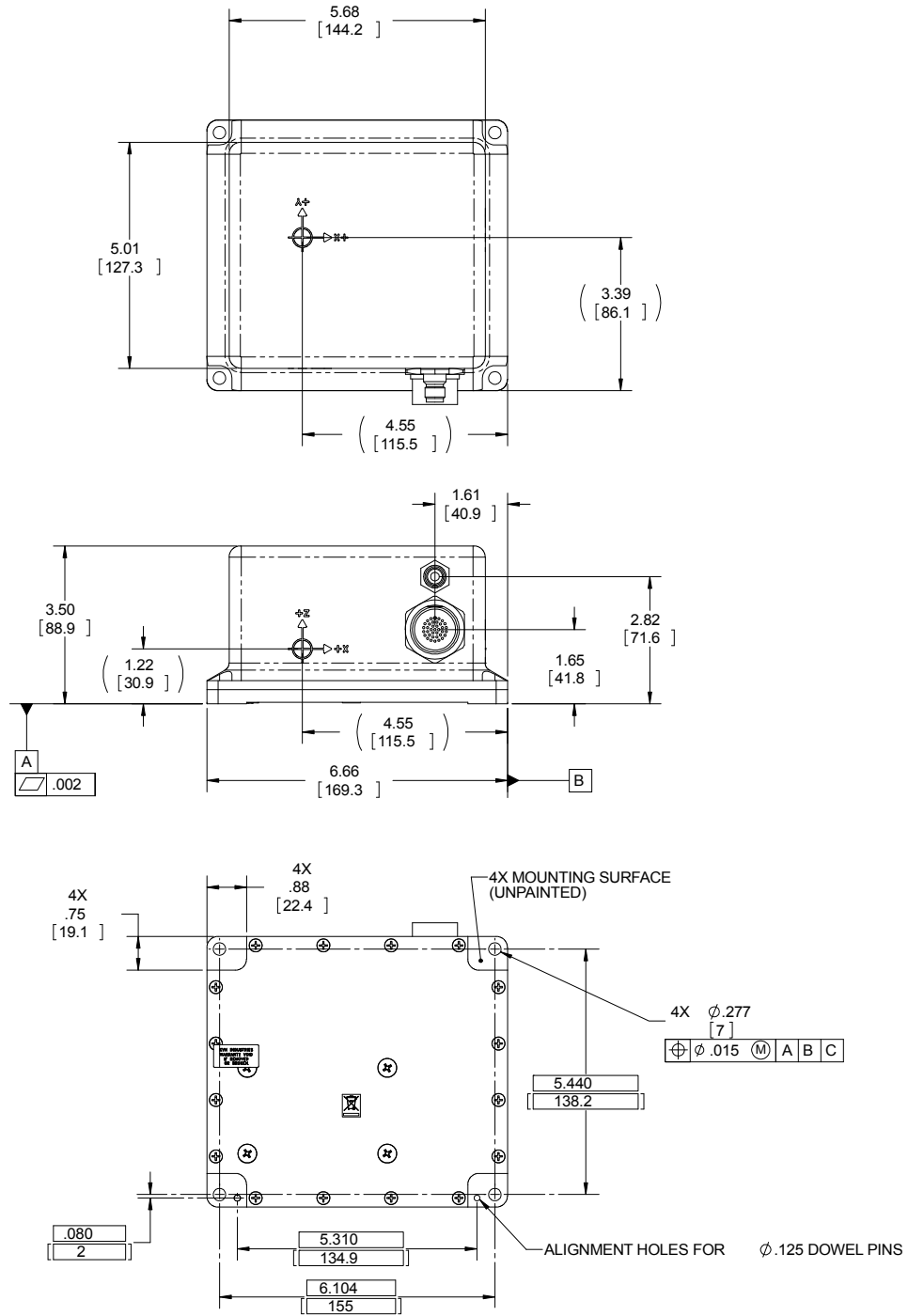

Figure 19: SPAN-CPT Top, Front and Bottom View



A.3 SPAN-CPT Cable

The NovAtel part numbers for the SPAN-CPT cables are:

- KVH Development Terminated Cable - 60723108
- KVH Standard Unterminated Cable - 60723107

Figure 20: SPAN-CPT Development Terminated Cable

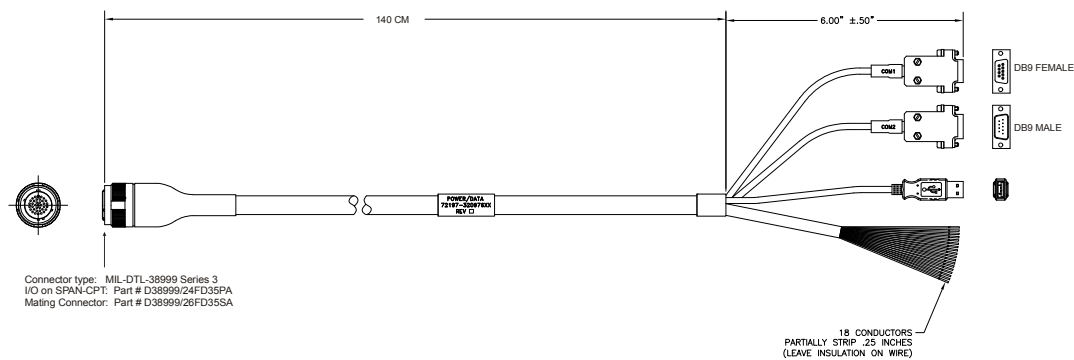

The SPAN-CPT cable also has a green ground line not shown in the drawing. The green ground line is grounded to the SPAN-CPT connector and enclosure.

Table 11: SPAN-CPT 60723108 - KVH Development Terminated Cable Pin-Out

Pin #	Function	Wire Pair	Wire Color	Female DB9 to COM1	Male DB9 to COM2	USB
1	Power Return	Red / Green	Green			
2	9-18 VDC Power Input		Red			
3	COM1 RS-422 TX (+) / RS-232 TX from Receiver	Red / Black	Red	2		
4	COM1 RS-422 TX (-) / RS-232 RTS from Receiver		Black	8		
5	COM1 RS-422 RX (+) / RS-232 RX to Receiver	White / Black	White	3		
6	COM1 RS-422 RX (-) / RS-232 CTS to Receiver		Black	7		
7	RS-422 Select In Tie together with pin 8 to select RS-422	White / Violet	White			
8	RS-422 Select Out Tie together with pin 7 to select RS-422		Violet			
9	COM1 Signal Ground		Grey	5		
10	USB D (+)	Blue / Black	Blue			3
11	USB D (-)		Black			2
12	USB Signal Ground		Violet			4
13	Odometer Power	White-Red / White-Black	White-Red			
14	Odometer Power Return		White-Black			
15	ODO SIGA	White-Brown / White-Black	White-Brown			
16	ODO SIGA Inverted		White-Black			
17	ODO SIGB	White-Orange / White-Black	White-Orange			
18	ODO SIGB Inverted		White-Black			
19	COM2 RS-232 TX from Receiver		Red		3	
20	COM2 RS-232 RX to Receiver		White		2	
21	COM2 RS-232 RTS from Receiver		Orange		7	
22	COM2 RS-232 CTS to Receiver		Brown		8	

Table 11: SPAN-CPT 60723108 - KVH Development Terminated Cable Pin-Out (continued)

Pin #	Function	Wire Pair	Wire Color	Female DB9 to COM1	Male DB9 to COM2	USB
23	No Connection					
24	No Connection					
25	COM2 Signal Ground		Black		5	
26	IMU RS-232 TX Diagnostics		White-Orange			
27	IMU RS-232 RX Diagnostics		White-Yellow			
28	IMU RS-232 Diagnostics Signal Ground		White-Blue			
29	PPS from Receiver		White-Red			
30	EVENT1 to Receiver		White-Brown			
31	Receiver Signal GND		White-Black			
32	CAN2L Receiver	Black / Green	Black			
33	CAN2H Receiver		Green			
34	CAN2 Signal Ground		White-Green			
35	No Connection					
36	No Connection					
37	Chassis GND		Green			

Table 12: SPAN-CPT 60723107 - KVH Standard Un-terminated Cable Pin-Out

Pin #	Function	Wire Pair	Wire Color
1	Power Return	White / Black	White
2	9-18 VDC Power Input		Black
3	COM1 RS-422 TX (+) / RS-232 TX from Receiver	White / Black	Black
4	COM1 RS-422 TX (-) / RS-232 RTS from Receiver		White
5	COM1 RS-422 RX (+) / RS-232 RX to Receiver	White / Black	Black
6	COM1 RS-422 RX (-) / RS-232 CTS to Receiver		White
7	RS-422 Select In Tie together with pin 8 to select RS-422		White
8	RS-422 Select Out Tie together with pin 7 to select RS-422		White
9	COM1 Signal Ground		White
10	USB D (+)	White / Black	Black
11	USB D (-)		White
12	USB Signal Ground		White
13	Odometer Power	White / Black	White
14	Odometer Power Return		Black
15	ODO SIGA	White / Black	Black
16	ODO SIGA Inverted		White
17	ODO SIGB	White / Black	Black
18	ODO SIGB Inverted		White
19	COM2 RS-232 TX from Receiver		White
20	COM2 RS-232 RX to Receiver		White
21	COM2 RS-232 RTS from Receiver		White
22	COM2 RS-232 CTS to Receiver		White
23	No Connection		
24	No Connection		
25	COM2 Signal Ground		White
26	IMU RS-232 TX Diagnostics		White
27	IMU RS-232 RX Diagnostics		White
28	IMU RS-232 Diagnostics Signal Ground		White
29	PPS from Receiver	White / Black	White
30	EVENT1 to Receiver		Black
31	Receiver Signal Ground		White
32	CAN2L Receiver	White / Black	White
33	CAN2H Receiver		Black
34	CAN2 Signal Ground		White
35	N/C		
36	N/C		
37	Chassis Ground		White

The following is a list of the replacement parts available. If assistance or additional components are required, contact the local NovAtel dealer or Customer Service.

B.1 SPAN-CPT System

Part Description	NovAtel Part
KVH Enclosure	80023524
KVH Standard Unterminated Cable	60723107
KVH Development Terminated Cable	60723108
SPAN-CPT Quick Start Guide	GM-14915124
SPAN-CPT User Manual	OM-20000122
SPAN on OEM6 Family Firmware Reference Manual	OM-20000144
OEM6 Family Firmware Reference Manual	OM-20000129

B.2 Accessories and Options

Part Description	NovAtel Part
Optional NovAtel GPSAntennas: Model 532 (for aerodynamic applications) Model 702 (for high accuracy applications) Model 702L (for L-Band applications) Model 533 (for high performance base station applications)	ANT-A72GA-TW-N GPS-702 GPS-702L ANT-C2GA-TW-N
Optional RF Antenna Cable: 5 metres 15 metres	GPS-C006 GPS-C016

1. *Why don't I hear sound from the SPAN-CPT?*

The SPAN-CPT does not make noise. Check that the multi-purpose I/O cable is connected properly. Check the input power supply. A minimum of 12 V should be supplied to the system for stable SPAN-CPT performance. The supply should also be able to output at least 16 W over the entire operating temperature range.

2. *Why is the INS solution status 'INS_INACTIVE'?*

The INS alignment routine does not begin until the system has solved for time. This requires that an antenna is attached and satellites are visible to the system. Verify that time is solved by checking the time status in the header of any standard header SPAN log such as BESTPOS. When the time status reaches FINESTEERING the inertial filter starts and the INS begins attempting to align.

3. *How can I access the inertial solution?*

The INS/GNSS solution is available from a number of specific logs dedicated to the inertial filter. The INSPOS, INSPVA, INSVEL, INSSPD and INSATT logs are the most commonly used logs for extracting the INS solution. These logs can be logged at any rate up to the rate of the IMU data (100 Hz). Further details on these logs are available in [SPAN on OEM6 Firmware Reference Manual](#).

4. *Can I still access the GNSS-only solution while running SPAN?*

The GNSS-only solution is still available when running SPAN. Logs such as PSRPOS, RTKPOS and OMNIPOS are still available. The best available GNSS-only solution is available in the BESTGNSSPOS log. Any non-INS logs should be logged at a maximum rate of 5 Hz when running SPAN. Only INS specific logs (documented in the [SPAN on OEM6 Firmware Reference Manual](#)) should be logged at rates higher than 5 Hz when running SPAN.

5. *What will happen to the INS solution when I lose GNSS satellite visibility?*

When GNSS tracking is interrupted, the INS/GNSS solution bridges through the gaps with what is referred to as free inertial navigation. The IMU measurements are used to propagate the solution. Errors in the IMU measurements accumulate over time to degrade the solution accuracy. For example, after one minute of GNSS outage, the horizontal position accuracy is approximately 8.4 m. The SPAN solution continues to be computed for as long as the GNSS outage lasts, but the solution uncertainty increases with time. This uncertainty can be monitored using the INSCOV log.

6. *All the accels measurements in my RAWIMUS logs are zero and the IMU status shows one or all accels are failing. What is wrong?*

Ensure a monotonic power supply on power up of your SPAN-CPT receiver. See *Connect Power* on page 16 for more information.

7. *The SPAN-CPT will not start /power on?*

The SPAN-CPT is connected to an incorrect power supply and the internal breaker has tripped. Shut down and disconnect the SPAN-CPT and reconnect to an properly supported power supply. Reapply power to the SPAN-CPT.

