



User's Manual

Precise® Controlled Atmosphere Glove Boxes and Precise® Basic Glove Boxes

CA Models

5220100

5220120

5220121

5220130

5220131

Voltage, Frequency

115V, 60 Hz

230V, 50 Hz

230V, 60 Hz

100V, 50 Hz

100V, 60 Hz

Basic Models

5220000

5220020

5220021

5220030

5220031

Voltage, Frequency

115V, 60 Hz

230V, 50 Hz

230V, 60 Hz

100V, 50 Hz

100V, 60 Hz

To receive important product updates,
complete your product registration card
online at **register.labconco.com**



*Protecting your
laboratory environment*

LABCONCO®

Labconco Corporation
8811 Prospect Avenue
Kansas City, MO 64132-2696
800-821-5525, 816-333-8811
FAX 816-363-0130
E-MAIL labconco@labconco.com
HOME PAGE www.labconco.com

Please read the User's Manual before operating the equipment.

The information contained in this manual and the accompanying products are copyrighted and all rights reserved by Labconco Corporation. Labconco Corporation reserves the right to make periodic design changes without obligation to notify any person or entity of such change.

Warranty

Labconco provides a warranty on all parts and factory workmanship. The warranty includes areas of defective material and workmanship, provided such defect results from normal and proper use of the equipment.

The warranty for all Labconco products will expire one year from date of installation or two years from date of shipment from Labconco, whichever is sooner, except the following;

- Purifier® Delta® Series Biological Safety Cabinets and PuriCare® Lab Animal Research Stations carry a three-year warranty from date of installation or four years from date of shipment from Labconco, whichever is sooner.
- SteamScrubber® & FlaskScrubber® Glassware Washers carry a two-year warranty from date of installation or three years from date of shipment from Labconco, whichever is sooner.
- Blood Drawing Chairs carry a ten year warranty.
- Carts carry a lifetime warranty.
- Glassware is not warranted from breakage when dropped or mishandled.

This limited warranty covers parts and labor, but not transportation and insurance charges. In the event of a warranty claim, contact Labconco Corporation or the dealer who sold you the product. If the cause is determined to be a manufacturing fault, the dealer or Labconco Corporation will repair or replace all defective parts to restore the unit to operation. Under no circumstances shall Labconco Corporation be liable for indirect, consequential, or special damages of any kind. This statement may be altered by a specific published amendment. No individual has authorization to alter the provisions of this warranty policy or its amendments. Lamps and filters are not covered by this warranty. Damage due to corrosion or accidental breakage is not covered.

Returned or Damaged Goods

Do not return goods without the prior authorization from Labconco. Unauthorized returns will not be accepted. If your shipment was damaged in transit, you must file a claim directly with the freight carrier. Labconco Corporation and its dealers are not responsible for shipping damages.

The United States Interstate Commerce Commission rules require that claims be filed with the delivery carrier within fifteen (15) days of delivery.

Limitation of Liability

The disposal and/or emission of substances used in connection with this equipment may be governed by various federal, state, or local regulations. All users of this equipment are required to become familiar with any regulations that apply in the user's area concerning the dumping of waste materials in or upon water, land, or air and to comply with such regulations. Labconco Corporation is held harmless with respect to user's compliance with such regulations.

Contacting Labconco Corporation

If you have questions that are not addressed in this manual, or if you need technical assistance, contact Labconco's Customer Service Department or Labconco's Product Service Department at 1-800-821-5525 or 1-816-333-8811, between the hours of 7:00 a.m. and 6:00 p.m., Central Standard Time.

TABLE OF CONTENTS

CHAPTER 1: INTRODUCTION	1
CHAPTER 2: PREREQUISITES	2
Support, Vibration & Preventive Requirements	3
Location Requirements	3
Exhaust Requirements for the Pressure Relief Valve	3
Electrical Requirements	4
Plumbing Requirements for Gas, Vacuum, & Drying Train	4
Space Requirements	5
CHAPTER 3: GETTING STARTED	6
Unpacking the Glove Box	7
Installing the Glove Box on a Supporting Structure & Work Surface	7
Connecting the Exhaust to the Pressure Relief Valve	8
Installation of Gloves to the Glove Ports	13
Connecting the Electrical Supply Source	13
Connect the Plumbing Lines for Gas, Vacuum & Drying Train	14
Validating the Glove Box	20
Oxygen Method Leak Testing Summary (ISO 10648-2)	22
Pressure Change Method Leak Testing Summary (ISO 10648-2)	23
CHAPTER 4: PERFORMANCE FEATURES AND SAFETY PRECAUTIONS	24
Performance Features	24
Safety Precautions	27
CHAPTER 5: USING YOUR GLOVE BOX	29
Routine Daily Work Procedures	29
Hazardous Use with Chemicals	31
Prohibited Acid Use	31
CHAPTER 6: MAINTAINING YOUR GLOVE BOX	32
Routine Maintenance Schedule	32
Initial Certification	33
Recertification	33
Fluorescent Light Replacement	33
Pressure Relief Valve Replacement	33
Service Valve and Pressure Gauge Replacement	34

CHAPTER 7: ACCESSORIZING YOUR GLOVE BOX	35
CHAPTER 8: ELECTRICAL SYSTEM TROUBLESHOOTING	42
APPENDIX A: REPLACEMENT PARTS	43
APPENDIX B: DIMENSIONS	45
APPENDIX C: SPECIFICATIONS	46
APPENDIX D: PRECISE CONTROLLED ATMOSPHERE PURGE & FILL REDUCTION RATES	47
APPENDIX E: LIFE SPAN FOR OXYGEN REMOVAL COLUMN & MOISTURE TRAP REMOVAL	49
APPENDIX F: IONIZER FAN PERFORMANCE CRITERIA	51
APPENDIX G: HELIUM LEAK TEST METHOD	53
APPENDIX H: PLUMBING DIAMGRAMS	55
APPENDIX I: PRESSURE & FLOW RATE CONVERSIONS	57
APPENDIX J: REFERENCES	58
DECLARATION OF CONFORMITY	59

Chapter 1: Introduction

Congratulations on your purchase of a Labconco Precise[®] Controlled Atmosphere Glove Box or Precise[®] Basic Glove Box manufactured with a one-piece molded polyethylene liner. The Precise Controlled Atmosphere Glove Box comes equipped with six valves, pressure relief valve and two chamber pressure gauge indicators, which are omitted from the Precise Basic Glove Box. The Precise Basic Glove Box allows the end user to customize the glove box to their application needs or use the glove box in its simplest form. Both glove boxes are designed to provide an effective physical barrier between the laboratory and the glove box interior. The barrier provides three distinct advantages. First, it helps protect the technician from hazardous materials. Second, it protects materials and laboratory equipment inside the main chamber from the effects of exposure to ambient air, oxygen, and moisture levels. Third, it provides a protective, leak-tight environment for your research, testing, or production procedures; the leak rate of the glove box is rated Class 1 for controlled atmosphere chambers per ISO 10648-2 test methods. Each Precise Controlled Atmosphere Glove Box or Precise Basic Glove Box is helium leak tested at the factory to ensure no leaks greater than 1×10^{-4} cc/sec.

The Precise Glove Boxes offer many unique features to enhance performance. To take full advantage of them, you **must** read and understand this manual and keep it handy for future reference. If you are unfamiliar with how the Precise Glove Boxes operate, please review *Chapter 4: Performance Features and Safety Precautions* before you begin working in the glove box. Even if you are an experienced user, please review *Chapter 5: Using Your Glove Box* so you can use the glove box efficiently.

Chapter 2: Prerequisites

Before you install the glove box, you need to prepare your site for installation. You must be certain that the area is level and of solid construction. In addition, a dedicated source of electrical power should be located near the installation site to power the glove box. Additionally, the glove box should be strategically placed in the lab to provide efficient workflow and prevent operator interference from normal traffic flow.

Carefully read this chapter to learn the requirements for your installation site:

- The support, vibration and preventive requirements.
- The location requirements.
- The exhaust requirements for the pressure relief valve.
- The electrical power requirements.
- The plumbing requirements for gas, vacuum, and dry train.
- The space requirements.

Refer to *Appendix B: Precise Glove Box Dimensions* for complete glove box dimensions.

Refer to *Appendix C: Precise Glove Box Specifications* for complete electrical and environmental conditions, specifications and requirements.

Support, Vibration and Preventive Requirements

In the preparation of a glove box site, please consider the following:

- A bench or stand that is rigidly mounted to the floor or fixed to the wall, but not both, may be appropriate. 35" to 40" (889mm to 1,016mm) is typical for standing height (Labconco stands offered in Chapter 7 vary from 33" to 40" or 838mm to 1,016mm).
- The corners of a building typically have less vibration than the center, which promotes analytical balance stability.
- The bench typically should not contain any vibration-producing equipment, such as shakers or pumps.
- A marble slab with dampening pads placed within the enclosure is an effective low cost means of controlling vibration for analytical balance operation (see *Chapter 7: Accessorizing Your Glove Box*).

Location Requirements

The Precise Glove Boxes have been designed to rest on a typical 29"-30" (737mm-762mm) deep work surface. The height should be 35"-40" for standing position. Avoid placing the glove box in high traffic areas where walking might disrupt the operator or experimentation.

Exhaust Requirements for the Pressure Relief Valve

To prevent over or under pressurization of the main glove box chamber, the Precise Controlled Atmosphere Glove Box includes a pressure relief valve that activates at pressures and vacuums above +6" water gauge or below -6" water gauge.



WARNING: The overpressurization of air at positive pressure would allow any contaminants inside the glove box to vent into the room. To control this venting into the laboratory, Labconco offers three pressure relief valve ventilation accessories. All three of these pressure relief valve ventilation accessories are shown in detail in Chapter 3 and can be ordered from Chapter 7.

Please see Chapter 7 to order the pressure relief valve and other valve accessories for the Precise Basic Glove Box.

The first option for venting the pressure relief valve is for ducting unfiltered air to the outside via a 4" nominal diameter exhaust duct. The second and third options for venting the pressure relief valve will add HEPA filters and/or carbon filters to the exhaust duct and allow the vented air back into the laboratory or to the outside. The HEPA filtered and carbon filtered pressure relief vent kits may be combined if so desired. All pressure relief valve vent kits include a 4" diameter thimble duct connection to aid in the connection to the building exhaust blower preventing the pressure relief valve from activating due to the negative pressure of the building exhaust. Labconco offers accessory remote blowers listed in Chapter 7 for your convenience in venting the pressure relief to the outside. These blowers have a 6" diameter nominal inlet and a 4" x 6" duct transition is necessary to adapt from the 4" diameter thimble connection provided with all relief valve kits.



WARNING: In the case of failure caused by excessive vacuum within the main chamber, the user must safely determine whether laboratory atmosphere entering the glove box could result in fire, explosive hazard or damage to property inside the glove box.

See Figures 3-1, 3-2, and 3-3 in Chapter 3 for ventilation connection diagrams of the vent kits.

Electrical Requirements

Electrical receptacles should be located nearby for connecting the glove box, or other optional laboratory equipment. The entire glove box is rated 115V, 8A or 230V, 4A or 100V, 8A. One duplex outlet is located inside the glove box and is rated for 115V, 5A or 230V, 2A or 100V, 5A. Additional power strip accessories are available and can be connected to the interior duplex outlet (see Chapter 7).

Plumbing Requirements for Gas, Vacuum, and Drying Train

The Precise Controlled Atmosphere Glove Box has four valves located on the main glove box chamber and two valves located on the transfer chamber. Two of the four valves on the main chamber should be used for the operation of the main chamber gas inlet and vacuum outlet lines. To prevent overpressurization, the gas inlet lines should be set at a pressure of 10-30 psi through the use of a gas supply pressure regulator. The other two valves on the main chamber can be used for connections to a recirculating drying train. Drying trains are recirculating contaminate removal traps, powered by vacuum pumps. They are used for the removal of oxygen and/or moisture from the main chamber atmosphere. They can also be used to remove organic vapors, acids, ammonia, or radioisotopes. See Chapter 7 for ordering

optional drying train removal traps. The two valves on the transfer chamber are used for gas inlet and vacuum outlet lines. The transfer chamber lines can be connected together with the main chamber gas inlet and vacuum outlet lines to simplify gas and vacuum connections to both chambers. Illustrations for all gas, vacuum, and recirculating drying trains are shown in Figures 3-5 through 3-10 in Chapter 3.

All valves utilize 3/8" (9.5mm) compression fittings or 3/8" (9.5mm) hose barbs for soft tubing. Both styles are offered for your convenience. Accessory gas and vacuum tubing kits are described in Chapter 7. Should you require automatic chamber pressure controls, see Chapter 3 for details on the accessory Pressure Controller and Chapter 7 for ordering information. The Pressure Controller automatically monitors and controls pressures in both the main chamber and transfer chamber; it also automates the operation of purging and filling each chamber (gas outlet and gas inlet) up to 199 cycles. Consult your Safety Officer should you require ventilation and/or filtration of the vacuum pump exhaust. Filtered exhaust (0.2 micron) and contaminate removal traps are available for the vacuum pump (see Chapter 7). See Chapter 3 for typical installation of vacuum outlet and inert gas inlet lines and Appendix H for plumbing diagrams.

See Chapter 7 to order any valves and/or pressure/vacuum gauges for the Precise Basic Glove Box as these features have been omitted to enable the end user customization.

Space Requirements

The dimensions are shown in *Appendix B: Dimensions*. Adequate space to the right of the transfer chamber is required for loading and unloading.

Chapter 3: Getting Started

Once the site for your glove box is properly prepared, you are ready to unpack, inspect, install, and validate performance of your system. Read this chapter to learn how to:

- Unpack and move the glove box.
- Set up the glove box with the proper supporting structure and work surface.
- Connect an exhaust system to the pressure relief valve (if applicable).
- Install the gloves.
- Connect the electrical supply.
- Connect the plumbing lines for gas, vacuum, and drying train.
- Validate performance of the glove box.



Each Precise Glove Box model weighs 185 lbs. each (83 kg). The shipping container allows for lifting with a mechanical lift truck or floor jack. If you must lift the glove box manually, follow safe-lifting guidelines. Do not lift by the upper sheet metal façade and front panel as damage can occur to the glove box liner.

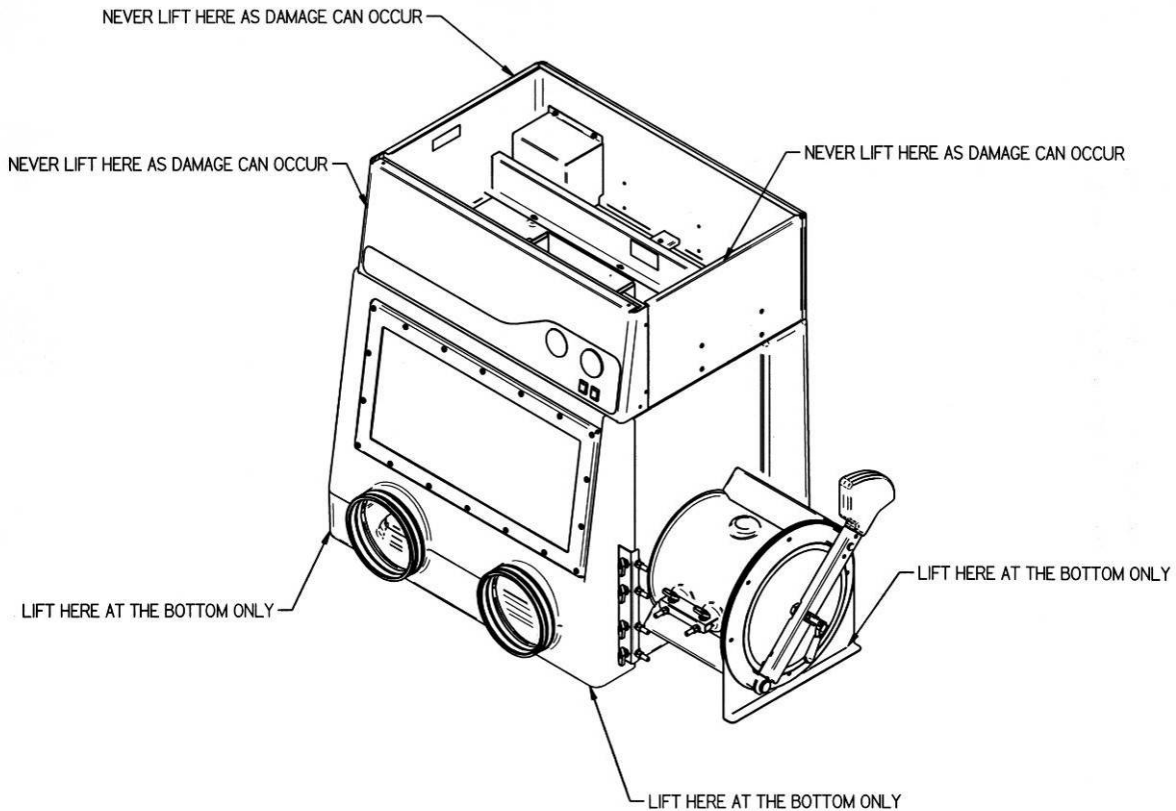

Lifting Instructions

Unpacking the Glove Box

We recommend that you do not remove the glove box from its shipping container until it is ready to be placed into its final location. Move the unit by placing a flat, low dolly under the shipping skid, or by using a floor jack.

Carefully remove the shrink-wrap and carton on the glove box and inspect it for damage that may have occurred in transit. **If damaged, notify the delivery carrier immediately and retain the entire shipment intact for inspection by the carrier.**



THE UNITED STATES INTERSTATE COMMERCE COMMISSION RULES REQUIRE THAT CLAIMS BE FILED WITH THE DELIVERY CARRIER WITHIN FIFTEEN (15) DAYS OF DELIVERY.



DO NOT RETURN GOODS WITHOUT THE PRIOR AUTHORIZATION OF LABCONCO. UNAUTHORIZED RETURNS WILL NOT BE ACCEPTED.



IF ENCLOSURE WAS DAMAGED IN TRANSIT, YOU MUST FILE A CLAIM DIRECTLY WITH THE FREIGHT CARRIER. LABCONCO CORPORATION AND ITS DEALERS ARE NOT RESPONSIBLE FOR SHIPPING DAMAGES.

Do not discard the packing material until you have checked all of the components and tested the glove box.

Installing the Glove Box on a Supporting Structure and Work Surface

Exercise caution when lifting or moving the glove box.

When installing the glove box onto a work surface or benchtop, ensure that the structure can safely support the combined weight of the glove box and any related equipment. The work surface should be as wide as the entire glove box to properly support it. The front of the glove box should be aligned with the front of the work surface for optimal comfort. A height of 35"-40" (889mm-1016mm) is appropriate for standing operation. Labconco base stands from Chapter 7 may be adjusted in height from 33"-40" (838mm-1016mm).

Connecting the Exhaust to the Pressure Relief Valve (If Applicable)



WARNING: The weight of the pressure relief exhaust ductwork system must be supported independently of the glove box superstructure or damage may occur.



The exhaust system should be installed by a qualified HVAC contractor.

As stated in Chapter 2, the main chamber pressure relief valve is exhausted back into the room unless an optional vent kit is installed. Figure B-1 in Appendix B shows the location of the pressure relief valve without any optional vent kits. Labconco provides pressure relief exhaust kits, which exhaust to the outside. HEPA and/or carbon filtered exhaust kits are also available. The HEPA and/or carbon filtered pressure relief exhaust kits also provide thimble duct connections for exhausting the pressure relief valve to the outside.

To connect the Pressure Relief Vent Valve to an exterior exhaust system, order the Ventilation Kit (#5242700) and refer to Figure 3-1. To provide HEPA filtered exhaust to the room or outside, order the HEPA Filtered Pressure Relief Vent Kit (#5238500) and refer to Figure 3-2. To provide carbon filtered exhaust to the room or outside, order the Carbon Filtered Pressure Relief Vent Kit (#5241200) and refer to Figure 3-3. The HEPA and carbon filtered exhaust kits may be used together if required. All kits are provided with full installation instructions, illustrations, and connections.

See Chapter 7, Accessories, to add a pressure relief valve (#5230600) to the Precise Basic Glove Box. A 2.06" (52.3mm) diameter hole must be drilled into the Precise Basic Glove Box shell. This hole is located on the 4.00" (101.6mm) diameter x 1.00" (25.4mm) high raised boss; the raised boss is located on the top of the glove box shell, in the front right side corner. Install the pressure relief valve from the inside with the gasket in place and tighten the retaining nut from the outside. After installation, the 2.00"-18 UNS (50.8mm) diameter threads on the pressure relief valve should be exposed. All vent kits attach to these threads as shown in Figures 3-1, 3-2, and 3-3. Figure B-1 in Appendix B shows a top view of the exposed threads on the pressure relief valve. A close up view of the pressure relief valve is shown below.

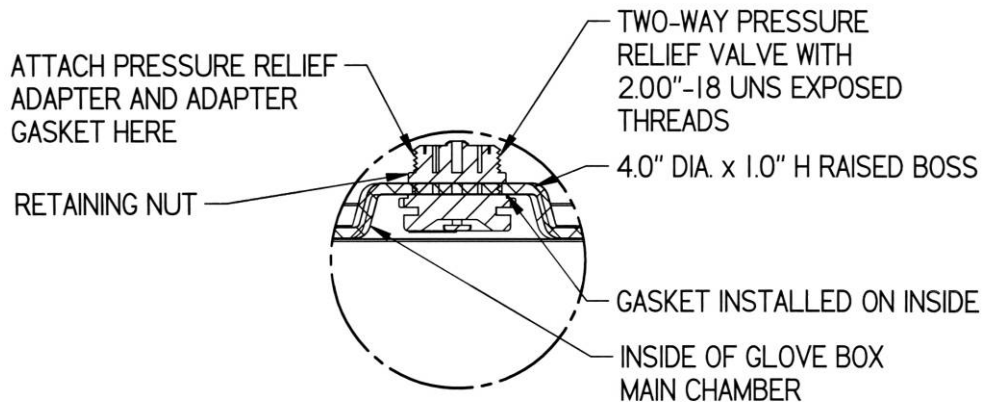

PRESSURE RELIEF DETAIL

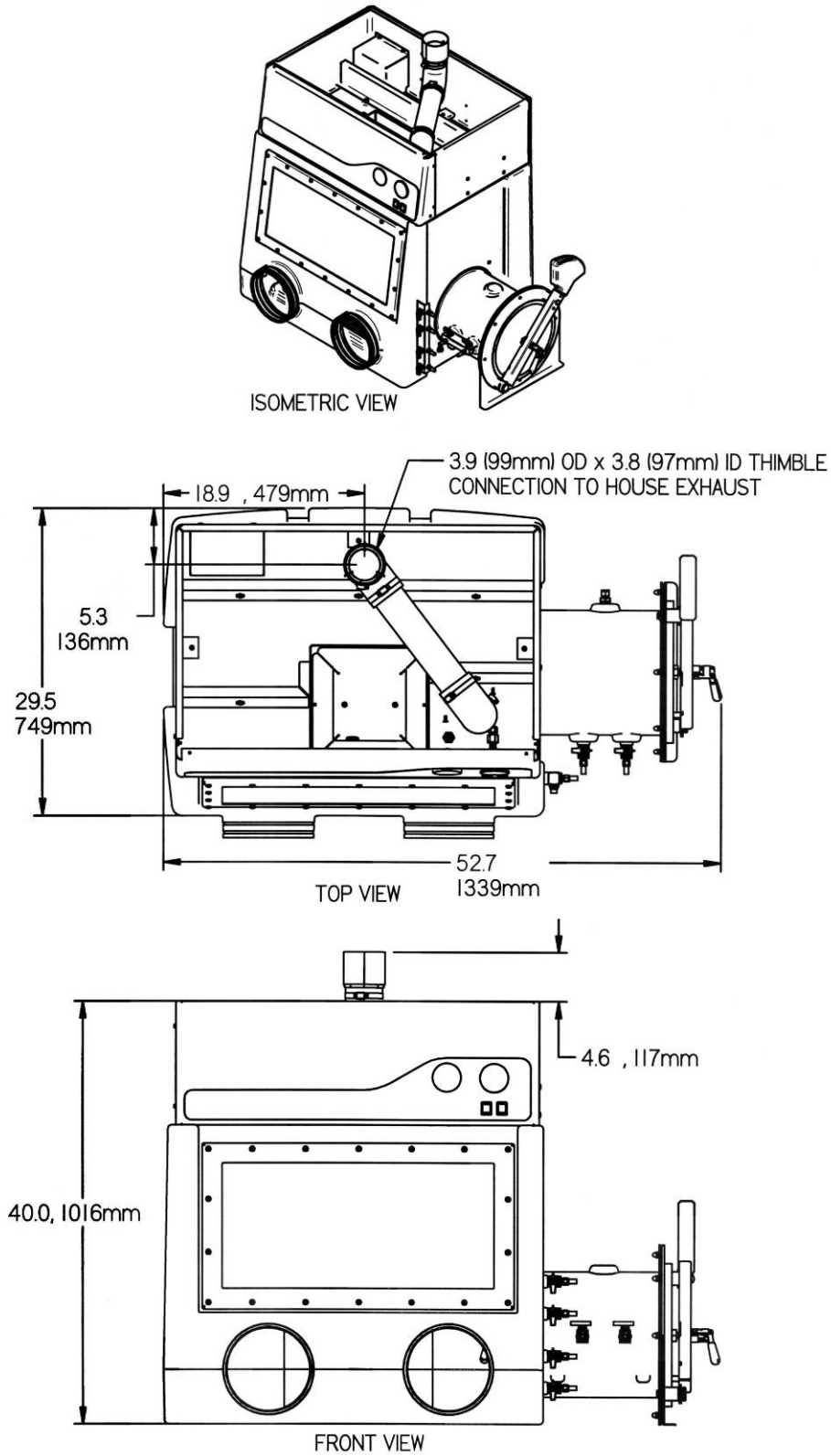

Figure 3-1
Pressure Relief Vent Kit (#5242700)

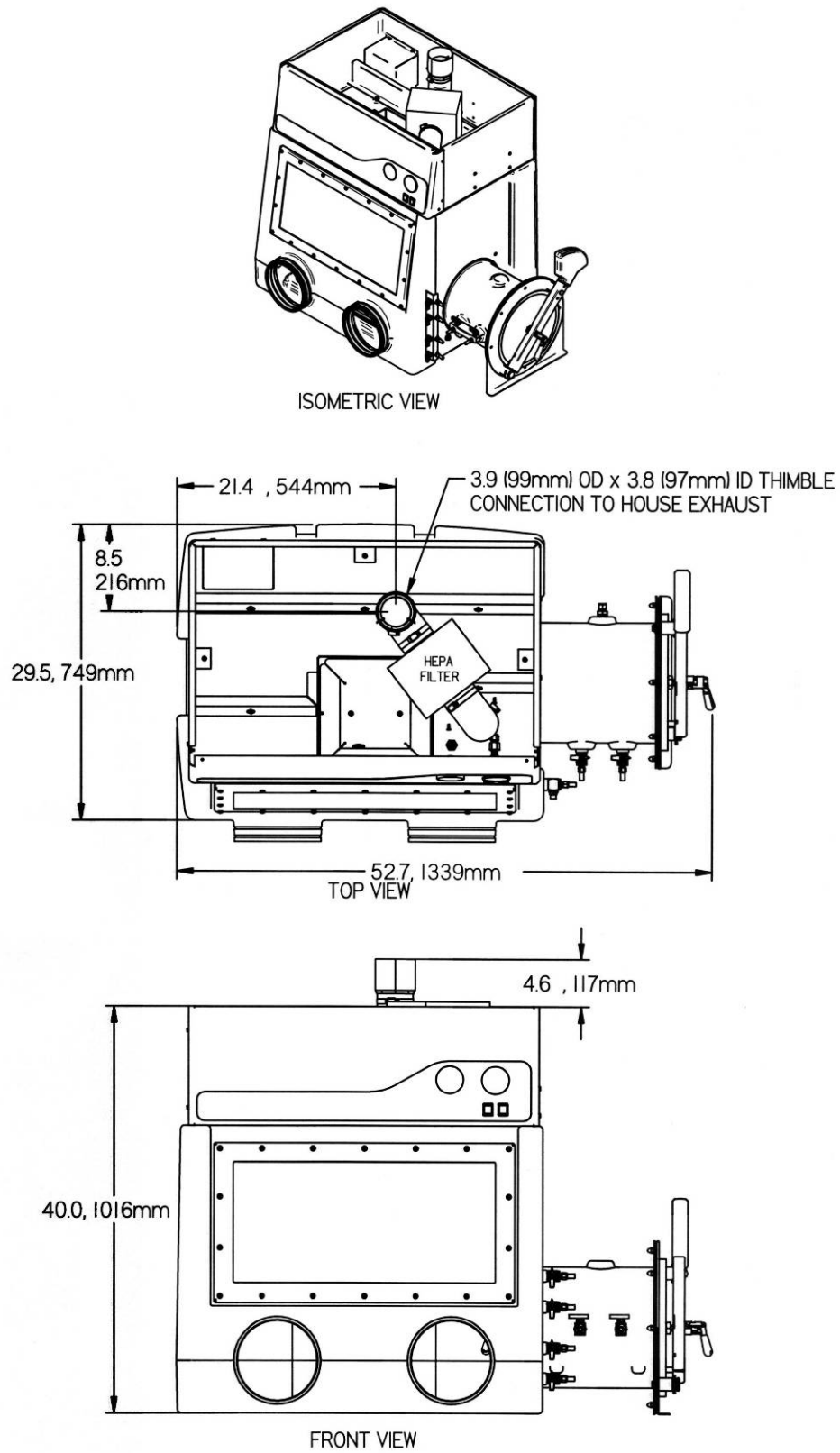

Figure 3-2
HEPA Filtered Pressure Relief Vent Kit (#5238500)

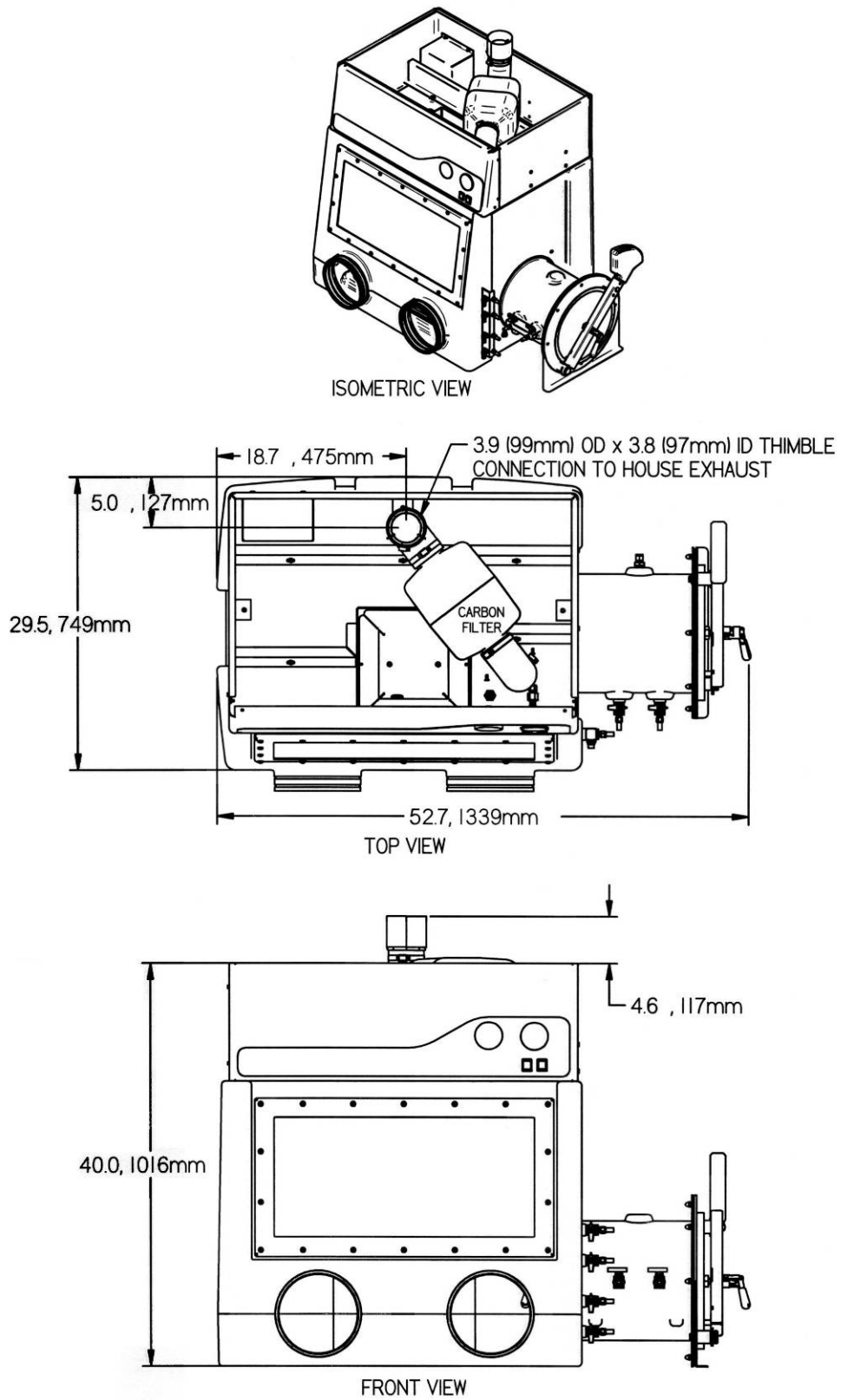

Figure 3-3
Carbon Filtered Pressure Relief Vent Kit (#5241200)

Installation of Gloves to the Glove Ports

With the thumbs up and in a right/left orientation, secure the gloves in place on the glove ports by stretching the beaded glove cuff into the glove port groove nearest the window. Install the separate 8" diameter O-ring over the gloves, into the outer groove of the glove port surface. Stainless steel band clamps are provided for securing the separate O-ring into the glove port groove. Replacement gloves and parts are listed in Chapter 7.

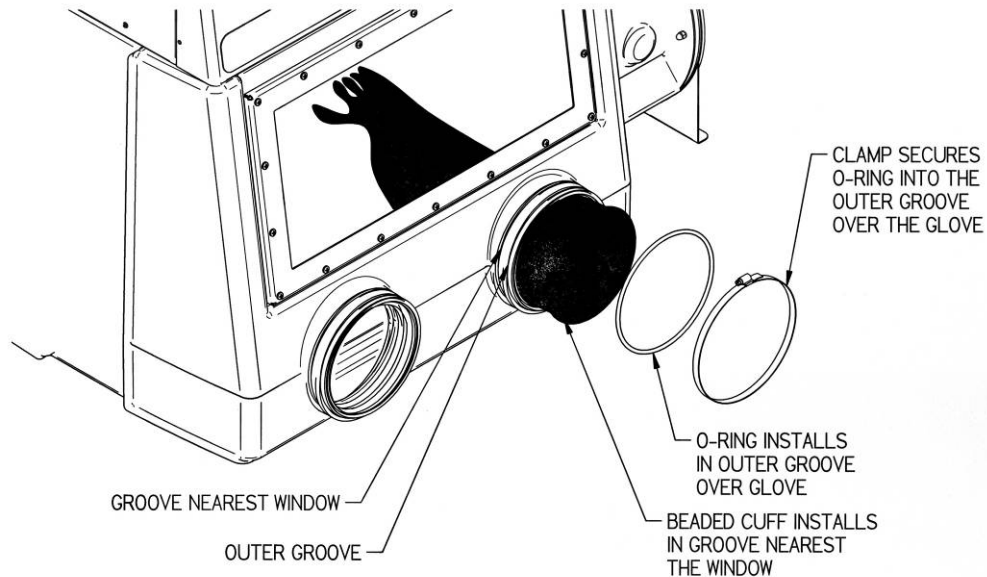

Figure 3-4
Glove Installation

Connecting the Electrical Supply Source to the Glove Box

115V, 60 Hz; 100V, 50 Hz; or 100V, 60 Hz Models

Connect the power cord supplied to the IEC electrical supply plug located on the back of the glove box. 115V or 100V models are rated at 8 amps total. **The maximum circuit load for the interior electrical duplex is 5 amps.**

230V, 50 Hz or 230V, 60 Hz Models

The same procedure applies for the 230V international models except the cords are shipped without an attached plug. Install the appropriate plug for your electrical specifications per local codes. The 230V, 50 Hz or 230V, 60 Hz models are both rated at 4 amps total. **The interior electrical duplex is rated at 2 amps.**

Connect the Plumbing Lines for Gas, Vacuum, and Drying Train

Labconco offers various vacuum and gas tubing installation kits listed in Chapter 7 for connecting gas and vacuum line, or drying train to the glove box. Refer to Figures 3-6, 3-7, 3-8, 3-9, and 3-10 that depict the installation tubing kits. The primary connecting method involves the use of 3/8" O.D. x 3/16" I.D. tubing for gas and vacuum line connections; a tube support insert **must** be placed inside the soft tubing to prevent the tube from disconnecting. The alternative connecting method uses a tube connector and hose clamp instead of a tube support insert. See Figure 3-5 (A and B) for both methods. Consult Figure 3-8, which depicts typical tubing connections with the accessory Automatic Pressure Controller. Vacuum pump model numbers can be found in Chapter 7. **Consult your Safety Officer to determine the suitability and requirement for venting the exhaust port of a vacuum pump to the outside.** An accessory 0.2 micron filter can be installed in the vacuum line to prevent particulate material contamination of the vacuum pump. The 0.2 micron filter can also be installed in the inert gas supply line connected to the main chamber and transfer chamber to insure a particulate free gas supply (see Chapter 7). If required, other accessory chemical traps can also be added to the vacuum line to prevent vacuum pump contamination (see Chapter 7). Refer to Appendix H for typical plumbing diagrams.

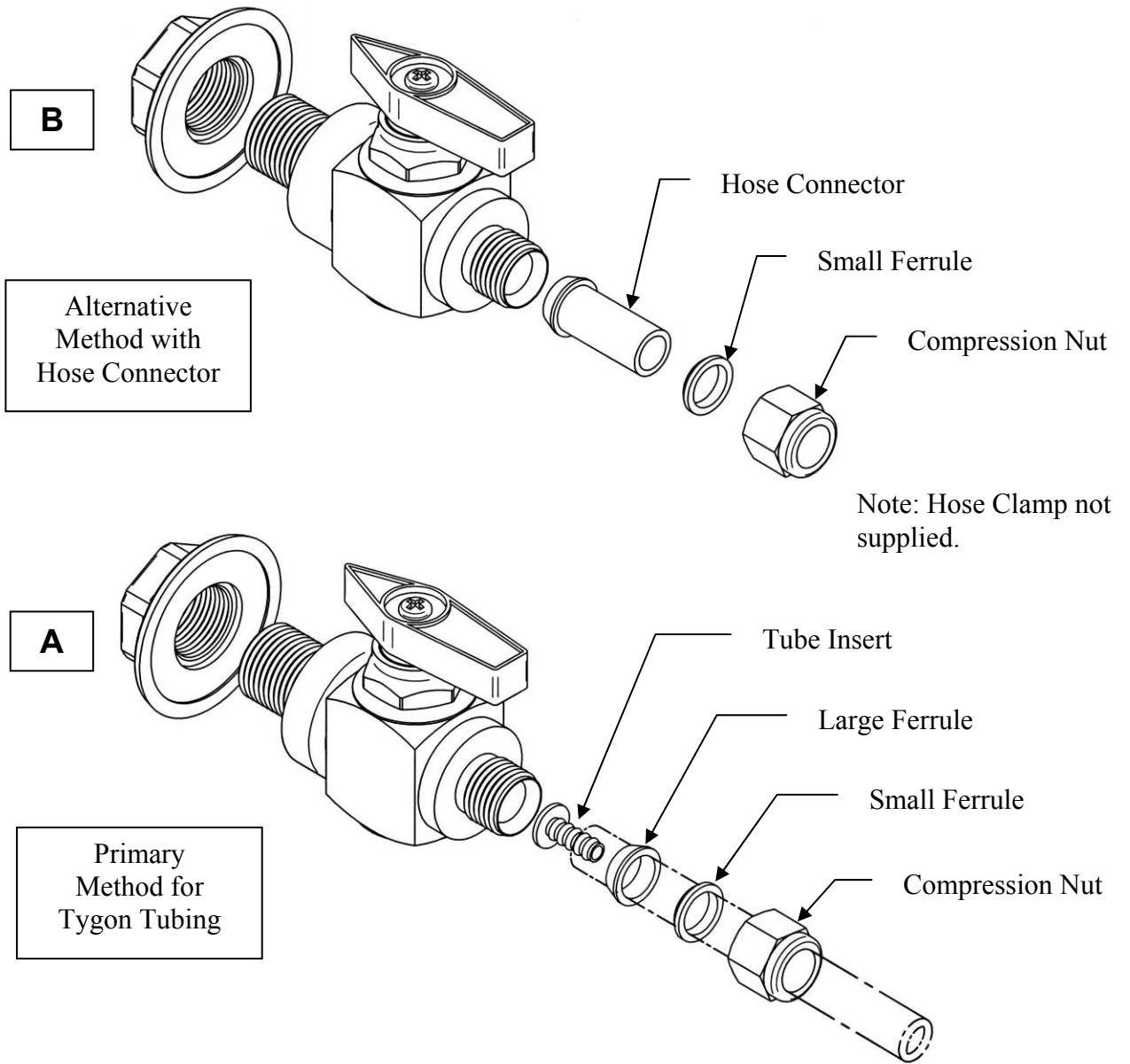

Figure 3-5
Close-up View of Typical Valve Connection Options

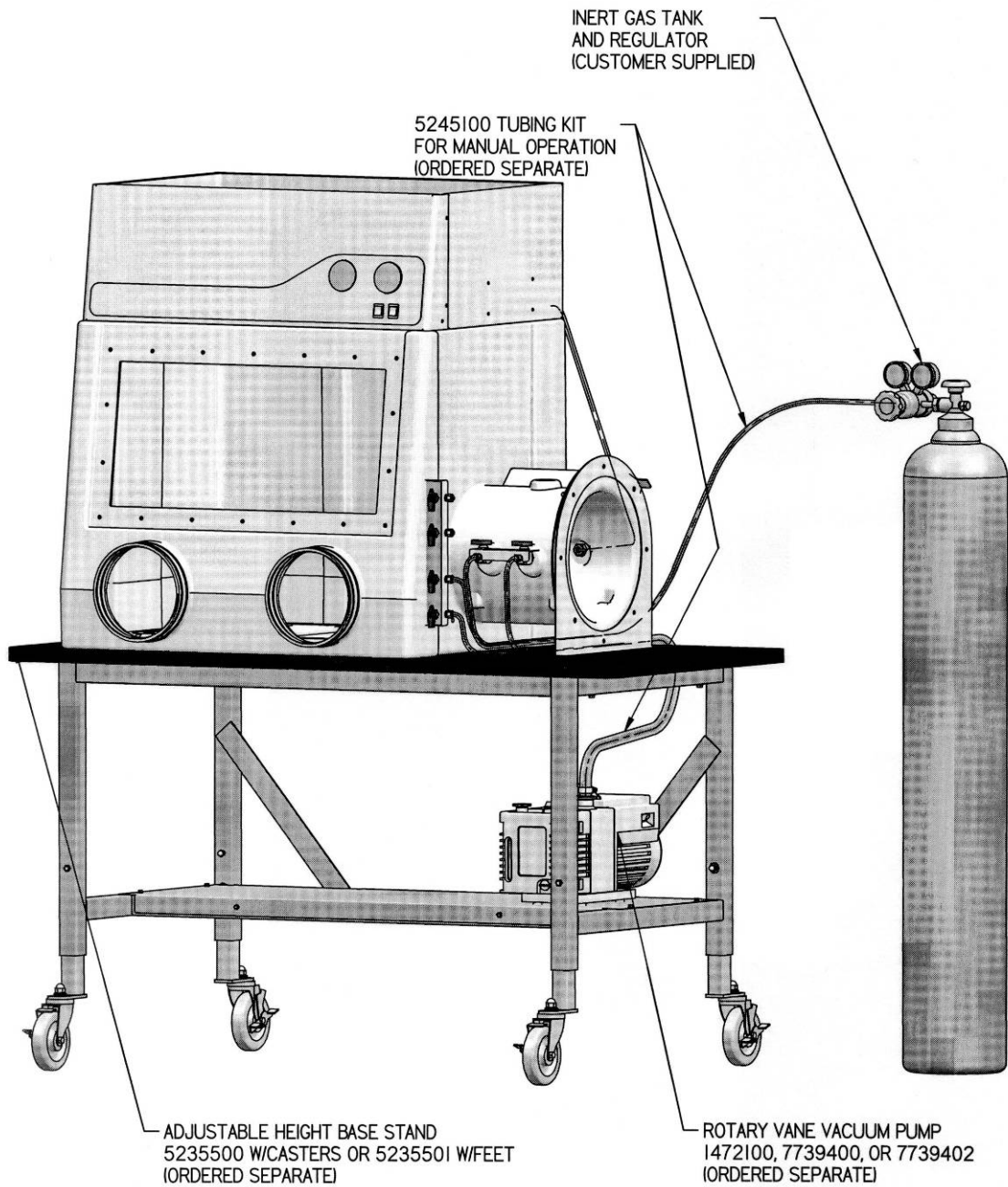

Figure 3-6
Typical Tubing Connections for Manual Valve Operation
(Tubing Connection Kit 5245100 provides full details)

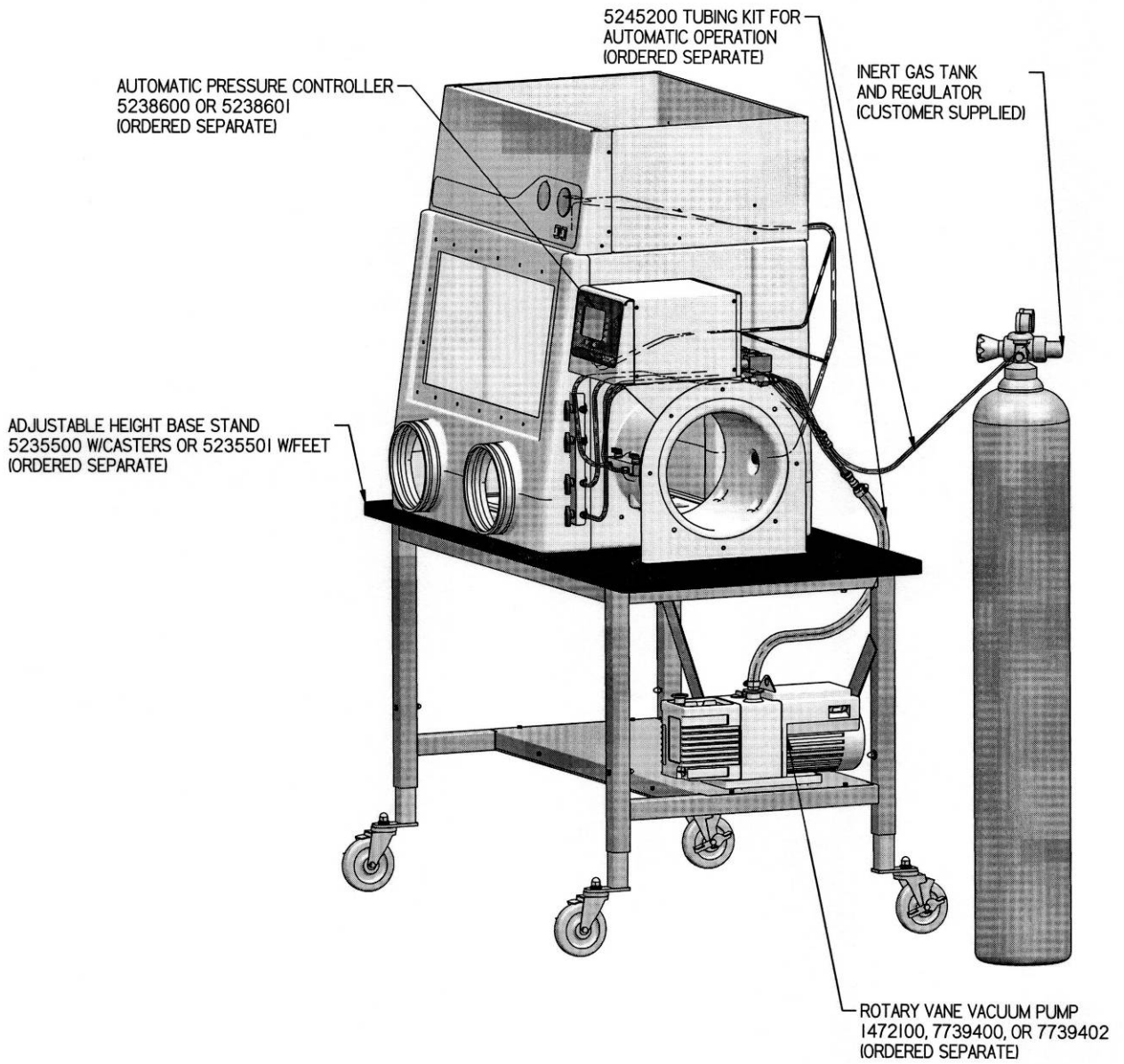

Figure 3-7
Typical Tubing Connections with Automatic Pressure Controller
(Tubing Connection Kit 5245200 provides full details)

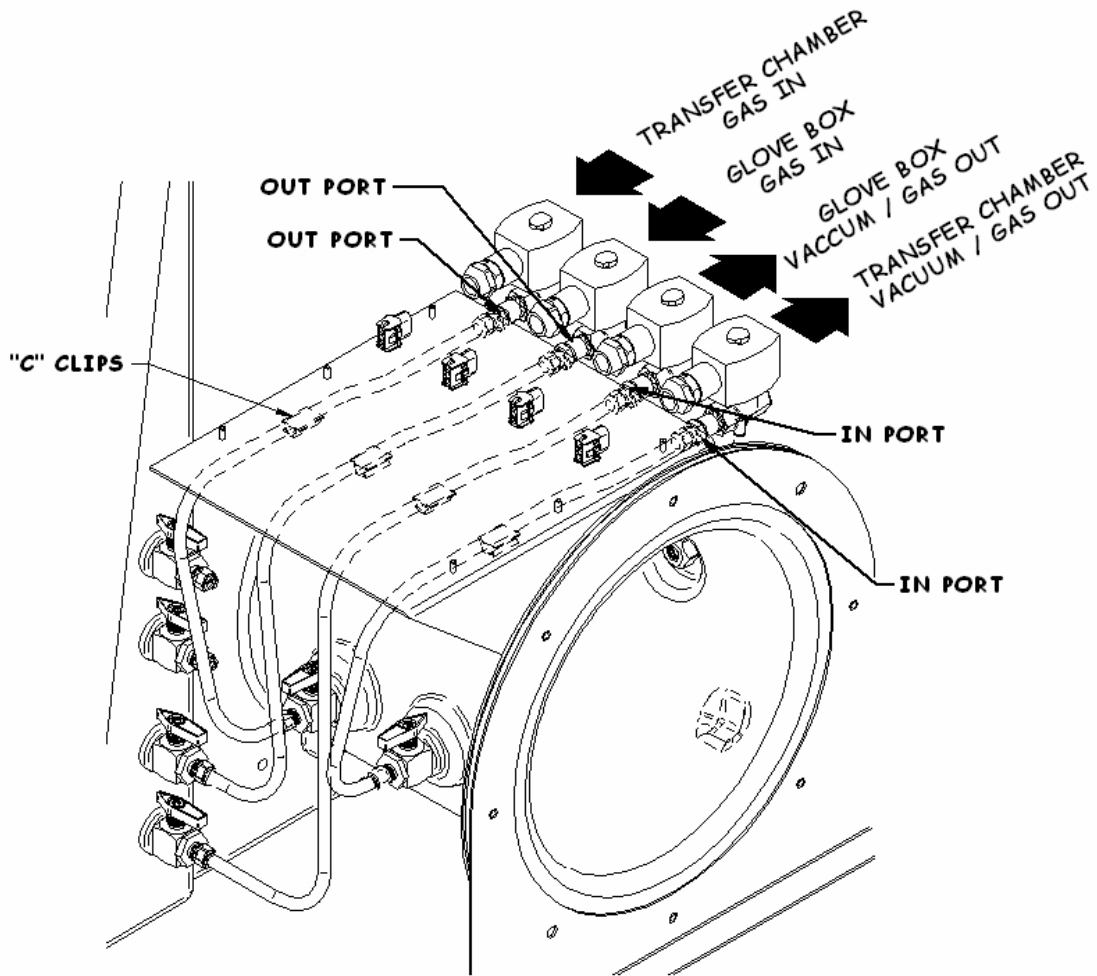

Figure 3-8
Typical Connections Shown with Connection to the
Automatic Pressure Controller
(Full details provided with Automatic Pressure Controller)

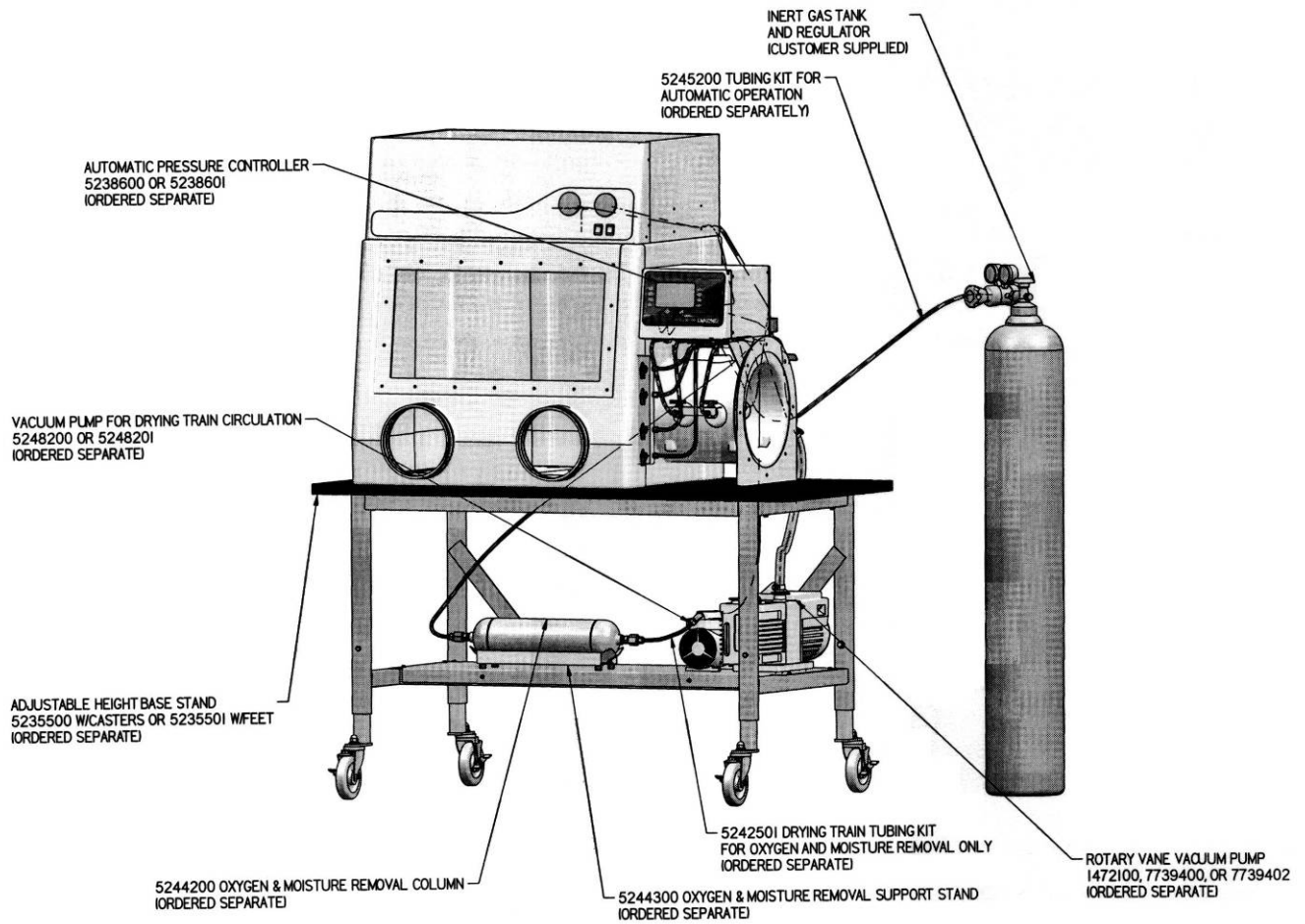

Figure 3-9
Typical Tubing Connections for Oxygen & Moisture
Removal Shown with the Automatic Pressure Controller
(Tubing Connection Kit 5242501 provides full details)

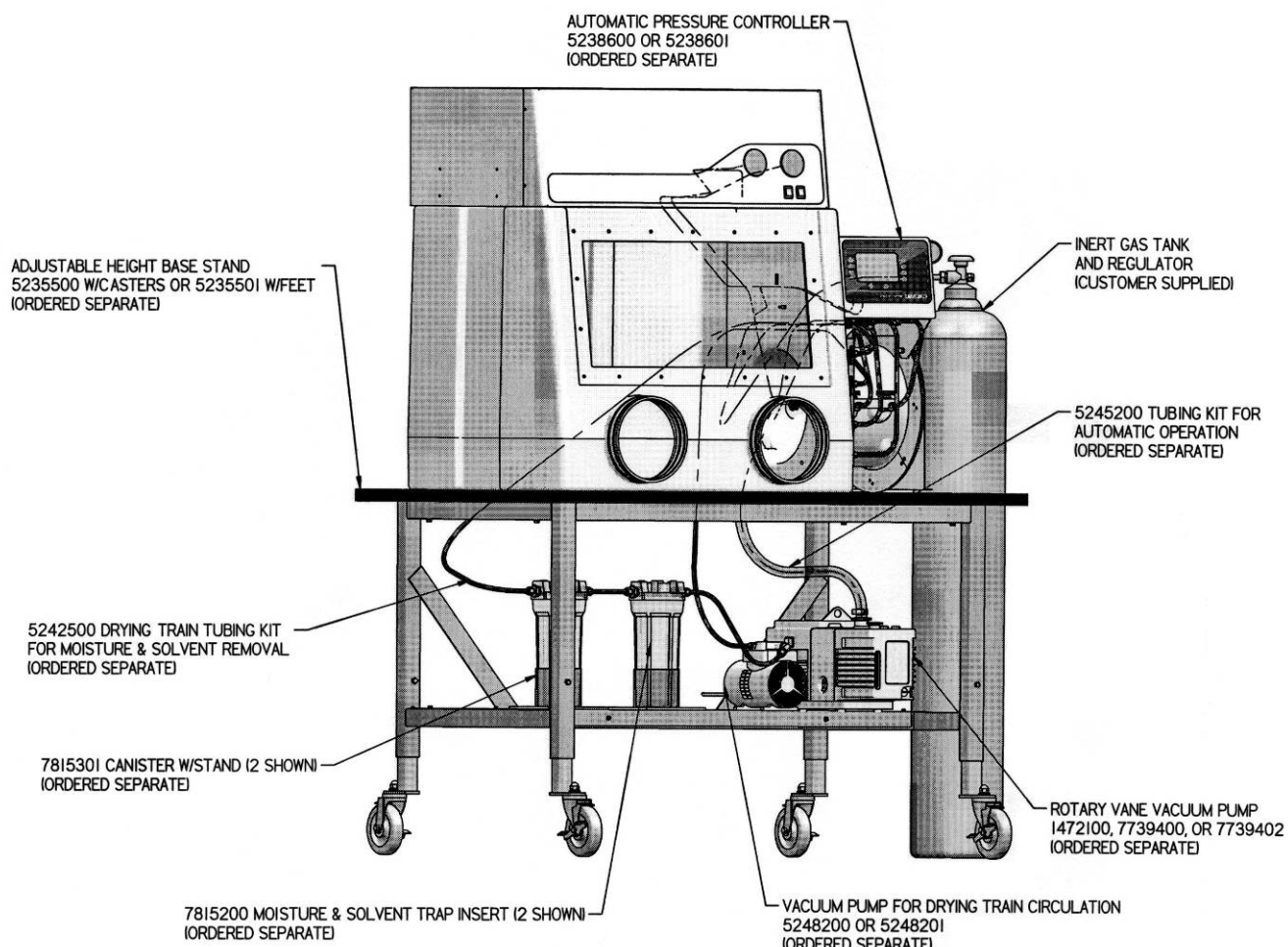

Figure 3-10
Typical Tubing Connections for Dual Moisture/Solvent Removal System Shown with the Automatic Pressure Controller (Tubing Connection Kit 5242500 provides full details)

Validating the Glove Box

Each Precise Glove Box has been helium leak tested at the factory for integrity and found to have no leaks greater than 1×10^{-4} cc/sec while at a positive pressure of 5 inches helium. Refer to Chapter 6, Initial Certification and Appendix G for Helium Leak Test Method.

Overall Glove Box Main Chamber Leak Test

The Precise Controlled Atmosphere Glove Box has been tested with an oxygen monitor detecting oxygen levels as low as 1 ppm; the rate of increase in oxygen over time was determined in accordance with the ISO 10648-2 oxygen leak decay test method. The results validate that the Precise Controlled Atmosphere Glove Box meets Class 1 conditions for controlled atmosphere

chambers. Figure 3-11 shows test results of the oxygen decay or oxygen level increase as a function of time. Per ISO specifications, Class 1 controlled atmosphere chambers have a specified hourly leak rate of less than 5×10^{-4} per Table 3-1 listed at the end of Chapter 3.

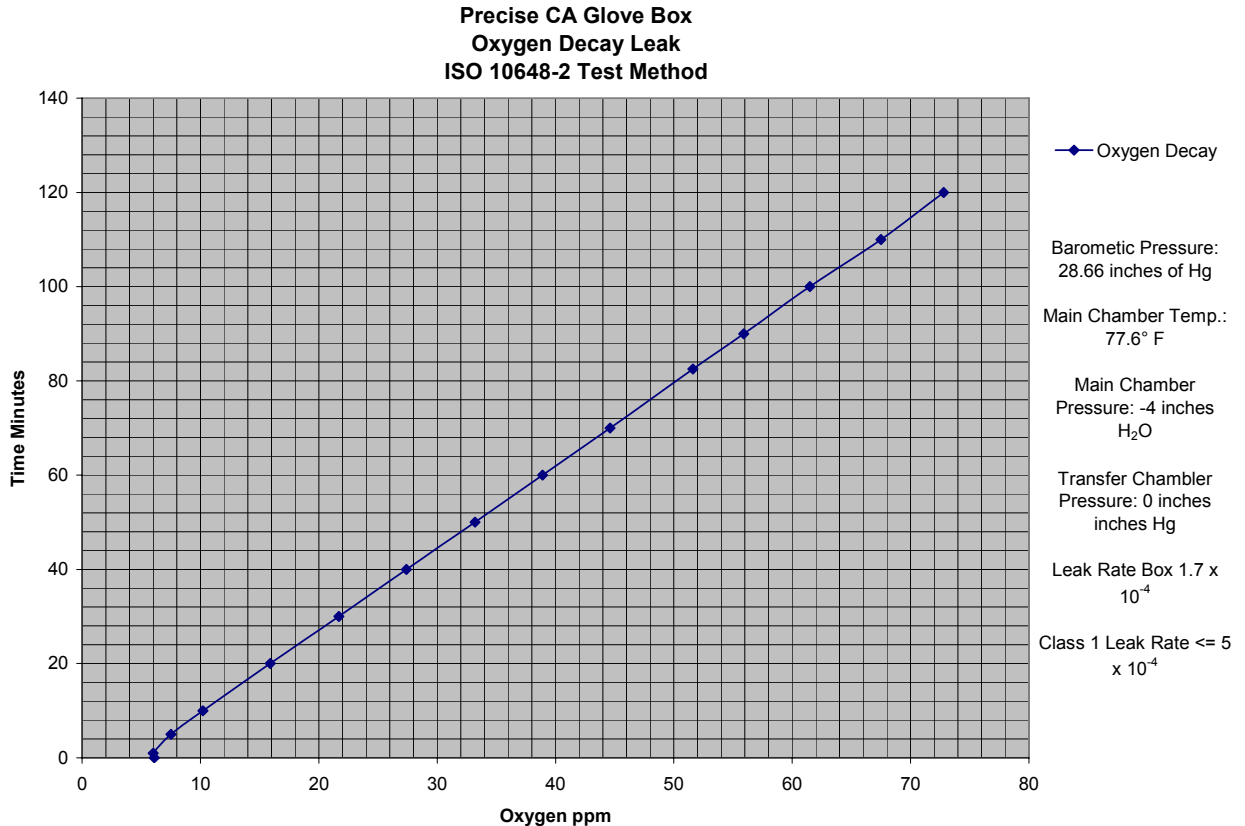

Figure 3-11

The validation requirements and required testing instruments for all applications shall be determined by the end user and Safety Officer. Other validation test methods such as pressure leak decay tests may be conducted per ISO 10648-2 standards. The pressure leak decay test may be performed, but the pressure inside the glove box must be adjusted accurately for temperature and barometric pressure.

These pressure leak decay tests are conducted under negative pressure of -250 Pa (-1" water gauge) for operational use or -1000 Pa (-4" water gauge) for the acceptance test; the pressure leak decay tests are usually performed under stable barometric pressure and temperature conditions to minimize the effect of these variables.

A 0.1°C fall in temperature results in an equivalent pressure change of -34 Pa or -0.14 inches of water gauge. A 0.01 inches of mercury rise in barometric pressure results in an equivalent pressure change of -34 Pa or -0.14 inches of water gauge.

Table 3-1
Classification of Glove Box Containment per ISO 10648-2

Class	Hourly Leak Rate (T_f)	Usage Example
1	$\leq 5 \times 10^{-4} \text{ hr}^{-1}$	Controlled atmosphere with high inert gas purity conditions
2	$< 2.5 \times 10^{-3} \text{ hr}^{-1}$	Controlled atmosphere under inert gas conditions or permanently hazardous atmosphere
3	$< 10^{-2} \text{ hr}^{-1}$	Permanently hazardous atmosphere
4	$< 10^{-1} \text{ hr}^{-1}$	Atmosphere which could be hazardous

The required classification of leak tightness of each glove box **must** be decided by the end user, their Safety Officer, and any oversight authorities.

Oxygen Method Leak Testing Summary (ISO 10648-2)

The method consists of measuring the increase in the oxygen concentration as a function of time inside the glove box main chamber, previously purged with an inert gas. The difference in the oxygen concentration between the end and the beginning of the test, calculated on an hourly basis, gives the hourly leak rate T_f :

$$T_f = 300 * (O_{2f} - O_{2i}) / (t * 10^6) \text{ where}$$

O_{2f} is the final oxygen concentration (ppm).

O_{2i} is the initial oxygen concentration (ppm).

t is the duration of the test in minutes.

$300 = 60 \times 100/20$ where 60 represents 60 minutes in an hour and 100/20 represents 20% oxygen in normal air.

Note: Use negative pressure of 1000 Pa (-4" water gauge) for acceptance test and negative pressure of 250 Pa (-1" water gauge) for operational test.

Pressure Change Leak Testing Method Summary (ISO-10648-2)

The method consists of measuring the pressure rise per unit time after establishing a negative pressure in the main chamber of the glove box. Use -1000 Pa for the acceptance test and -250 Pa for the operational test. The hourly leak rate includes adjustments for barometric pressure and temperature changes which can be calculated as T_f :

$T_f = (60/t) * ((P_n T_1 / P_1 T_n) - 1)$ where

t is the duration of the test in minutes.

P_1 is the absolute pressure (ambient barometric pressure minus under pressure) at the first reading in Pascals.

P_n is the absolute pressure (ambient barometric pressure minus under pressure) at the last reading in Pascals.

T_1 is the temperature at the first reading in Kelvin.

T_n is the temperature at the last reading in Kelvin.

60 represents 60 minutes in an hour.

T in Kelvin is equal to degrees Celsius + 273.

Chapter 4: Performance Features and Safety Precautions

Performance Features

The Precise Controlled Atmosphere Glove Box comes fully equipped with six valves, pressure relief valve, and two pressure gauges. The Precise Controlled Atmosphere Glove Box is designed to meet the needs of the laboratory scientists requiring an inert atmosphere for sensitive ambient air operations. Labconco has engineered the Precise Controlled Atmosphere Glove Boxes to meet the ISO 10648-2 Class 1 atmosphere leak specification. The Precise Controlled Atmosphere Glove Box protects the technician from hazardous materials and protects valuable laboratory materials from the effects of oxygen and moisture exposure. The Precise Controlled Atmosphere Glove Boxes provide a leak tight environment for manufacturing and chemical research procedures. The Precise Basic Glove Box allows the end user to customize the glove box or use the glove box in its simplest form. See Figure 4-1 to refer to a detailed description of the Precise Controlled Atmosphere Glove Box main performance features.

1. **Molded One-Piece Chemically-Resistant Glove Box Shell** made of medium density polyethylene, which provides superior chemical resistance. The molded liner is seamless and easy to clean with coved interior corners.
2. **Six Manual Valves** are installed on the controlled atmosphere glove box; four on the main glove box chamber and two on the transfer chamber. Two of the four valves on the main glove box chamber should be used for vacuum purge and gas fill operations to develop an inert or controlled atmosphere. The two valves on the transfer chamber are used to purge and fill the transfer chamber, removing ambient air contaminants, and preserving the controlled atmosphere within the main chamber when transferring materials. The six valves can be installed separately on Precise Basic Glove Boxes with modification to the glove box liner. See Chapter 7 to order vacuum pumps and valve kits.

Generally, 75-100 purge and fill cycles are required to reduce moisture and oxygen levels below 1% (see Appendix D). 100-150 purge and fill cycles will typically reduce moisture and oxygen levels to 0.3% or 3,000 ppm. After a 1% or less moisture and oxygen level is achieved, the other two valves on the main chamber can be opened when they are connected to a recirculating moisture and/or oxygen removal system. The installation and operation of a removal system can further reduce and maintain low moisture (<50 ppm) and oxygen (<5 ppm) levels. The installation of the accessory Automatic Pressure Controller automates the purge and fill process (up to 199 cycles). See Chapter 7 to order the drying train removal accessories and the Automatic Pressure Controller.

3. **Transfer Chamber Vacuum Gauge** provides an indicator of vacuum pressure in the transfer chamber. The indicator reads from 0 to 29 inches of mercury vacuum. **WARNING: A steel reinforced high vacuum sleeve must be used with full vacuum.**

Note: The Transfer Chamber Vacuum Gauge and High Vacuum Sleeve are included on Precise Controlled Atmosphere Glove Boxes and can be ordered from Chapter 7 for modification of Precise Basic Glove Boxes.

4. **Main Chamber Pressure Gauge** gives indication of main glove box pressure. The gauge reads from -5 to +5 inches of water pressure. **Note:** The Main Chamber Pressure Gauge is included on Precise Controlled Atmosphere Glove Boxes and can be ordered from Chapter 7 for modification of Precise Basic Glove Boxes.
5. **Glove Ports** are 8" nominal size and molded into the main glove box shell. The double grooves provide two points of glove restraint for containment and safe changing of the gloves.
6. **Neoprene Gloves** are supplied with the glove box, .015" thick, 30" long, one pair, size 9 ³/₄. See Appendix A for replacement parts and Chapter 7 for a description.
7. **Removable Framed Glass Window** is 1/4" thick laminated safety glass and is reinforced with powder-coated steel frame. The removable glass window frame provides access to the interior for loading large apparatus. When removed, the window opening is 26.4" wide x 12.5" high (670mm wide x 317mm high). The framed glass window is sealed with a one-piece molded neoprene gasket. See Chapter 7 for optional Acrylic Viewing Window with Frame.
8. **Fluorescent Lamp** provides 30-40 foot candles of interior illumination on the work surface. The lamp may be replaced from outside the glove box. See Chapters 6 and 7 for replacement.
9. **Control Panel** consists of the main chamber pressure gauge, transfer chamber vacuum gauge, and control switches for the light and duplex outlet.
10. **Work Surface** is black chemically-resistant phenolic core and sealed to the glove box floor. The black surface aids proper cleaning and provides improved visibility of white powders. Phenolic core has superior chemical resistance and stain resistance.

11. **Interior Switched Duplex** is located on the glove box ceiling. The innermost outlet of the duplex labeled “AUX” is controlled by the switch located on the front control panel. The other outlet is on constantly when the glove box is connected to an electrical supply. An accessory Electrical Power Strip can be connected to the outlet to provide more electrical receptacles (see Chapter 7). **The interior duplex is rated at 115V, 5A or 230V, 2A or 100V, 5A.**
12. **Transfer Chamber Doors** have a molded one-piece neoprene gasket with a quick operating latch for user convenience. The counterweighted doors swing up to save space. **IMPORTANT: The transfer chamber must have an optional High Vacuum Sleeve if the chamber is converted for vacuum operation on Precise Basic Glove Boxes.** See Chapter 7.
13. **Pressure Relief Valve** provides a safety relief for over or under pressurization events within the glove box main chamber. The valve is set to relieve positive or negative pressures above +6 or below -6 inches of water gauge. **The designed operational maximum limits for the Precise Glove Box is +/-5 inches of water gauge.** See Chapters 2, 3, and 7 for exhausting properly. The pressure relief valve is included on Precise Controlled Atmosphere Glove Boxes and can be ordered from Chapter 7 for modification of the Precise Basic Glove Boxes. See Chapter 3 for modification instructions adding a Pressure Relief Valve to the Precise Basic Glove Box.

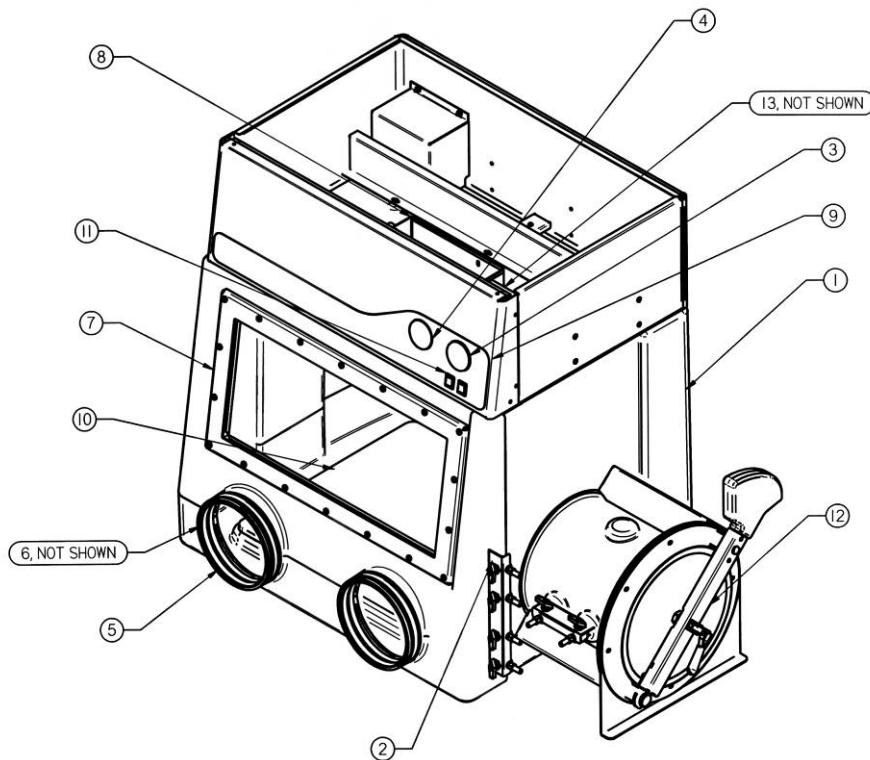

Figure 4-1
Performance Features
(Precise Controlled Atmosphere Glove Box Shown)

Safety Precautions

1. It is the responsibility of the user to determine the suitability of this product for the intended applications. Consult your Safety Officer for application review.
2. Although the glove box has been engineered to maintain optimum operator safety, caution should always be used while working. Prior to using the glove box, check to make sure that the main chamber pressure is set for comfortable glove manipulation. **Changes in glove position will affect pressure in the glove box.**
3. Use good housekeeping in the enclosure at all times. Clean up spills immediately. Periodically clean enclosure interior per your standard operating procedures for the specific chemicals in use.
4. This product is not designed or intended to be explosion proof. It is the responsibility of the user to determine and avoid the lower explosive limits and flammability of the enclosed gases used within the controlled atmosphere glove box. The user is responsible for taking proper precautions to prevent equipment damage or injury due to an explosion or combustion of chemicals.
5. The use of flammable gases or solvents in the glove box should be limited. Care must be taken to ensure against the concentration buildup of flammable or explosive gases or vapors. Use of an open flame or exposure to high heat should be avoided in the glove box as the heat will damage the liner. **DANGER: Use of added oxygen inside the glove box must be avoided to prevent explosion, death, or serious injury.**
6. Perchloric acid use in this enclosure is prohibited.
7. Radioisotope material usage in the glove box should be approved by your Safety Officer.
8. A qualified certification technician should test the glove box before it is initially used.
9. The glove box should be recertified at least annually after installation.
10. The use of safety goggles, protective clothing, and any other personal protective equipment recommended by your safety officer should be observed.
11. **The pressure relief valve provides protection from over or under pressurization and should be filtered and/or ducted to the outside if working with hazardous materials.** Consult your Safety Officer. When operating the transfer chamber gas inlet and vacuum outlet valves, insure the inner transfer door is closed. Failure to do so can result in the pressure relief valve opening, thereby, introducing laboratory air into the glove box main chamber or glove box air into the laboratory.

12. **All powders, gases, and particulates removed by the operation of the vacuum pumps connected to this glove box are to be filtered and/or ducted to the outside.**
13. **Exhaust vacuum pumps should be filtered and/or ducted to the outside when using hazardous materials.** Consult your Safety Officer. Manipulations that generate gases or vapors from toxic chemicals or radionuclides, must be evaluated carefully from the standpoint of buildup to dangerous levels. The decontamination of the glove box and compliance with applicable regulations is the responsibility of the operator and safety officer. Venting or filtering of vacuum pump exhaust is the operator's responsibility.
14. Ensure that the glove box is connected to electrical service in accordance with local and national electrical codes. Failure to do so may create a fire or electrical hazard. Do not remove or service any electrical components without first disconnecting the glove box from electrical service.
15. Ensure only trained operators use the glove box. New users **must** review the User's Manual and become familiar with the operation of the glove box.
16. Tag the glove box with appropriate warnings, if work inside the glove box is hazardous or needs to remain untouched. Tag the glove box if it requires servicing.
17. Consult your Safety Officer before removing any hoses to vacuum pumps, gas lines, pressure gauges, or exhaust hoses; they may be contaminated with chemicals used inside the glove box.

Chapter 5:

Using Your Glove Box

Now that the installation of your glove box is completed, you are ready to use it.

Read this chapter to learn about:

- Routine Daily Work Procedures.
- Hazardous Use with Chemicals.
- Prohibited Acid Use.

Routine Daily Work Procedures

Planning

- Thoroughly understand procedures and equipment required before beginning work. Work from a written plan.
- Arrange for minimal disruptions, while the glove box is in use.
- Consult your Safety Officer for personal protective equipment recommendations and operating pressure confirmation.

Start-up

- Basic start-up procedure includes: turning on the vacuum pump, opening the inert gas valve on the gas supply tank, and turning on the glove box light.

Loading Materials and Drying Train Set-Up

- Load only the materials and equipment required for the procedure. Do not overload the glove box. When loading, ensure the inner door is closed before opening the outer door. Then close the outer door.

- Perform purge and fill cycle on the transfer chamber using the vacuum outlet and gas inlet valves. Depending on the vacuum level achieved, it takes 1-5 cycles to reduce oxygen and moisture levels below 1%. Porous materials being transferred may require longer sustained vacuum purges to remove the oxygen and moisture trapped in the materials.
- After transferring materials to the main glove box chamber, perform the required purge and fill cycles on the main chamber using the vacuum outlet and gas inlet valves. To automate the purge and fill cycles (1-199) for both glove box chambers, the addition of the Automatic Pressure Controller (5238600 or 5238601) is recommended (see Chapter 7). Normally 75-100 purge and fill cycles will reduce moisture and oxygen levels below 1% (see Appendix D). An additional 30-50 cycles will reduce moisture and oxygen levels below 0.3% or 3,000 ppm. **The use of external glove port caps will expedite the purge and fill cycle times and help maintain low moisture and oxygen levels when the glove box is not in use.**
- Maintaining a slight main chamber positive pressure can help to preserve the glove box atmosphere. The moisture/oxygen permeation rates are reduced at slightly positive pressures (see Appendix E).
- Recirculating drying trains are **required** to further reduce and maintain oxygen and moisture levels below 1%. **Labconco oxygen and moisture removal drying trains can maintain oxygen levels below 5 ppm and moisture levels below 50 ppm.**
- Monitoring moisture and oxygen levels inside the glove box is **recommended** by using accessory monitors (see Chapter 7).

Work Techniques

- Segregate all clean and contaminated materials in the work area.
- Maintain work at a slightly negative pressure if working with hazardous compounds.
- Continuously run the recirculating oxygen and/or moisture drying train to **preserve** the inert atmosphere if so desired.

Transferring Materials to the Outside

- All open chemical weigh vessels or containers **must** be sealed before removing materials from the glove box main chamber.
- Upon completion of work, the main glove box chamber **must** be purged and filled approximately 5-10 times to remove airborne contaminants from the work area. The exact number of cycles should be determined by your Safety Officer.

- Objects in contact with previously contaminated internal atmospheres **must** be surface decontaminated or bagged before removal from the glove box through the transfer chamber.
- After placing materials to be removed in the transfer chamber and locking the internal door, the transfer chamber **must** be purged and filled approximately 1-5 times depending on vacuum level achieved. This ensures the removal of any remaining airborne contaminants before the outer door is opened. **Never** apply a high vacuum purge on sensitive electronic moisture and oxygen monitors. The exact number of cycles should be determined by your Safety Officer.

Shutdown

- To help preserve the controlled atmosphere, leave the glove box main chamber under slightly positive pressure and continuously run the recirculating drying train. The use of the accessory external glove port caps can assist in preserving the inert atmosphere (see Appendix E).
- Keep the outer door closed when not in use.

Hazardous Use with Chemicals

Hazardous chemicals may be used safely only when the glove box vacuum pump and pressure relief valve are both properly vented and/or filtered to the outside. Consult your Safety Officer for proper venting and filtering of the vacuum pump exhaust and the pressure relief valve for your application.

Prohibited Acid Use

Due to stainless steel components, the glove box interior **must** not be exposed to mineral acid use. The glove box life span will be limited with use of mineral acids.

NOTE: Labconco makes no claims about life span of the glove box with mineral acid use and warranties will become void.

Chapter 6: Maintaining Your Glove Box

Review this chapter on maintenance for the following:

1. Routine maintenance.
2. Initial certification.
3. Recertification.
4. Fluorescent light replacement.
5. Pressure relief valve replacement.
6. Service valve and pressure gauge replacement.

Routine Maintenance Schedule

Weekly

- Wipe down the interior surfaces of the glove box with a disinfectant or cleaner, depending upon the application.
- Using an appropriate cleaner and cloth, clean the exterior surfaces of the glove box, particularly the front and top, to remove any accumulated dust.
- Chart the pressure decay of the glove box, noting the change in pressure over short time periods. Adjust as necessary for temperature and barometric pressure changes. See *Chapter 3: Validating the Glove Box*.
- If required, monitor and record oxygen and moisture levels inside the glove box with accessory monitors (see Chapter 7).

Annually

- Replace the fluorescent lamp.
- Have the glove box certified by a qualified technician. See Certification and Recertification in Chapter 6.

Initial Certification

Each Precise Glove Box has been leak tested at the factory with helium gas at positive 5" w.g. pressure; no leaks greater than 1×10^{-4} cc/sec are allowable. The glove box should be certified by your Safety Officer before use, with one of the two tests listed below under Recertification. See Appendix G for Labconco Helium Leak Test Method performed on all glove boxes at the factory.

Recertification

Under normal operating conditions, the glove box should be recertified at the time of installation and at least annually thereafter. The certifier should choose and perform one of the following tests. Refer to Validating the Glove Box in Chapter 3.

- Oxygen Method Leak Test per ISO 10648-2 test methods.
- Pressure Change Leak Test per ISO 10648-2 test methods.

Fluorescent Light Replacement

1. Disconnect the power. Refer to Appendix A for replacement parts.
2. Locate the light reflector on the top of the glove box behind the front panel.
3. Remove the light reflector support by removing two hex nuts located on both sides of the light reflector.
4. Remove the old fluorescent lamp.
5. Reinstall the new fluorescent lamp and light reflector by reversing the steps above.

Pressure Relief Valve Replacement

1. Decontaminate the glove box interior, if required.
2. Wear appropriate protective equipment as determined by your Safety Officer.
3. Turn the glove box and vacuum pump OFF.
4. Disconnect the exhaust connection, if installed.
5. Loosen the large nut that secures the pressure relief valve.
6. Remove the pressure relief valve from the glove box interior.

7. Install the new pressure relief valve with the gasket to the inside. Tighten the large nut.
8. Turn the glove box ON and re-certify the glove box.
9. Refer to Appendix A, Appendix B and Chapters 3 and 7 for installation diagrams.

Service Valve and Pressure Gauge Replacement

1. Decontaminate the glove box interior, if required.
2. Wear appropriate protective equipment as determined by your Safety Officer.
3. Turn the glove box and vacuum pump OFF.
4. Remove the valve or pressure gauge by loosening the large nut for the valve or hardware for the pressure gauge. Remove the pressure hose connected to the pressure gauge.
5. Replace with the new valve with the gasket inside or replace with the new pressure gauge.
6. Tighten the large nut for the valve or the hardware for the pressure gauge and re-attach the pressure hose to the pressure gauge.
7. Turn the glove box ON and re-certify.
8. Refer to Appendix A and Chapters 3 and 4 for installation diagrams.

Chapter 7:

Accessorizing Your Glove Box

There are many ways to accessorize and modify the controlled atmosphere glove box for your individual requirements. These include many different accessories listed in this chapter.

- 1. Black Epoxy Flat Work Surface (Part #4882807)**
A solid epoxy resin 60" x 30" x 1.25" work surface is available to support the glove box.
- 2. 30" Standard Base Cabinet (Part #9900200)**
Two optional base cabinets can be ordered to support the 60" x 30" work surface and glove box. Contact Labconco for additional sizes.
- 3. Adjustable Height Base Stands with Attached Work Surface (Part #5235500 w/casters, Part #5235501 w/adjustable feet)**
These stands, 60" x 31", with attached black laminate work surfaces have an adjustable height range from 33" to 40" (838mm-1,016mm) and include a lower shelf for supporting accessory equipment.
- 4. Anti-Static Ionizer Fan (Part #5234400, 100/115V or Part #5234401, 230V International)**
Used for weighing operations and attaches to the ceiling of the glove box. The ionizer fan circulates ionized air inside the glove box to reduce static charge. Ionizer Replacement Points (set of 8 emitter electrodes) are ordered separately (Part #5235100). See Appendix F for additional information.
- 5. Balance Vibration Isolator (Part #5234600)**
Isolates building vibrations and aids with balance weighing. Includes a 20" x 13" x 2 1/4" marble slab with four isolator pads and type 304 stainless steel top cover to protect the porous marble.
- 6. Valve Kits**
The Precise Controlled Atmosphere Glove Box comes with six valves already installed. The Add-A-Valve Kit #5225701 includes one valve, O-ring, and nut for addition to the main chamber or the transfer chamber. Identifier Label Set for valves (Part #5236600) is ordered

separately. This kit can be used if additional valves are desired or valves are added to the Precise Basic Glove Box. For a complete installation of six valves, mounting brackets, pressure relief valve, and labels for the Precise Basic Glove Box, order Full Valve Kit #5232101. All valves require a 0.688" (17.5mm) diameter hole to be drilled for mounting.

7. Vacuum Aspirator Kit

Includes the valve, hose, canister, and vacuum pump for evacuating fluids around the work surface.

Part #	Descriptions
5241800	Vacuum Aspirator Kit, 115V
5241801	Vacuum Aspirator Kit, 230V International

8. Electrical Power Strips

These convenience electrical power strips are available in US and international versions and plug into the interior duplex of the glove box.

Part #	Descriptions
5211500	US Power Strip 115V, 4 Position, 5A
5210600	UK Power Strip 250V, 6 Position, 2A
5290400	European Power Strip 250V, 4 Position, 2A
5332600	Australian Power Strip 250V, 6 Position, 2A
5211501	Installation Tool

9. Electrical 9 Pin Sealed Pass-Through Kit (Part #5075619)

Includes sealed 9 pin (D-subminiature with male pins on one side and female pins on the other) connector and cord for data transfer to a typical printer outside the glove box from the balance. Note: Order the 9 pin installation kit separately which includes all the drill bits and hole saws for field installation (Part #5241100).

10. Remote Blowers and Dampers for Exhausting the Pressure Relief Valve and/or Vacuum Pump

Has a 1/4 hp direct drive motor and corrosion-resistant epoxy-coated steel housing and wheel with blower inlet of 6.00" ID. Outlet dimensions are 4.25" x 7.38" OD. Dampers allow airflow adjustment for blowers.

CFM @ Static Pressure-Inches of H ₂ O						
S.P.	0.0"	0.125"	0.25"	0.50"	0.75"	0.87"
CFM	595	560	515	420	300	167

Part #	Description
4863500	Remote Blower, 115 V, 60 Hz. 4.4 amps
4863501	Remote Blower, 115/230 V, 50 Hz, 5.6/2.8 amps International
3924000	6" Epoxy-Coated Steel In-Line Adjustable Damper
4724200	6" PVC In-Line Adjustable Damper

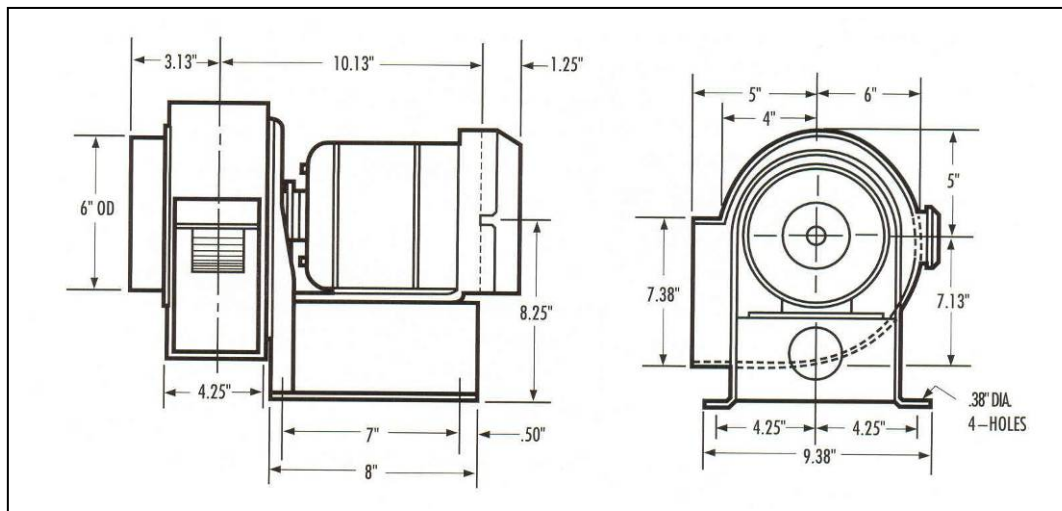

All dimensions in inches

11. Pressure Relief Vent Kits and Pressure Relief Valve

Pressure relief vent kits are detailed in Chapters 2 and 3 and include tubing connections and/or filters. Three pressure relief vent kits are available to vent either unfiltered air or filtered air. All pressure relief vent kits include a 3.9" (99mm) OD x 3.8" (97mm) ID nominal thimble for connection to a house exhaust. The pressure relief valve is factory installed on the Precise Controlled Atmosphere Glove Box, but is an accessory on the Precise Basic Glove Box. See Chapter 3 for installation.

Part #	Descriptions	Vent Options
5242700	Pressure Relief Vent Kit (No Filters)	Outside
5238500	HEPA Filtered Pressure Relief Vent Kit	Room or Outside
5241200	Carbon Filtered Pressure Relief Vent Kit	Room or Outside
5230600	Pressure Relief Valve (Basic add on)	All

Vent Kits 5238500 and 5241200 may be used together if required.

12. Gas Inlet / Vacuum Outlet Tubing Kits and Direct Drive Vacuum Pumps

These flexible vinyl tubing kits provide the necessary tubing and fittings to make connections to an inert gas supply tank and a rotary vane vacuum pump. See Figures 3-7 and 3-8.

Part #	Descriptions	Used With
5245100	Complete Gas/Vac Tubing Kit (Manual)	Manual Valves
5245200	Complete Gas/Vac Tubing Kit (Auto)	Pressure Controller
1472100	Direct Drive Vacuum Pump, 115V, 50/60Hz	Both
7739400	Direct Drive Vacuum Pump, 230V, 50/60Hz, NEMA 6-15P plug	Both, International Version
7739402	Direct Drive Vacuum Pump, 230V, 50/60Hz with reverse IEC plug	Both, International Version

13. Automatic Pressure Controller

The Pressure Controller allows the end user the convenience of automatically regulating pressure and vacuum within the glove box main chamber and transfer chamber. The end user can also automate the purge/fill cycles up to 199 cycles for each chamber. The vacuum and pressure can be automatically regulated between -5 to +5 inches of water gauge in the main chamber and between 0 to -29 inches of mercury gauge in the transfer chamber. See illustration below and figures in Chapter 3.

Part #	Descriptions
5238600	Pressure Controller 115V or 100V
5238601	Pressure Controller 230V International

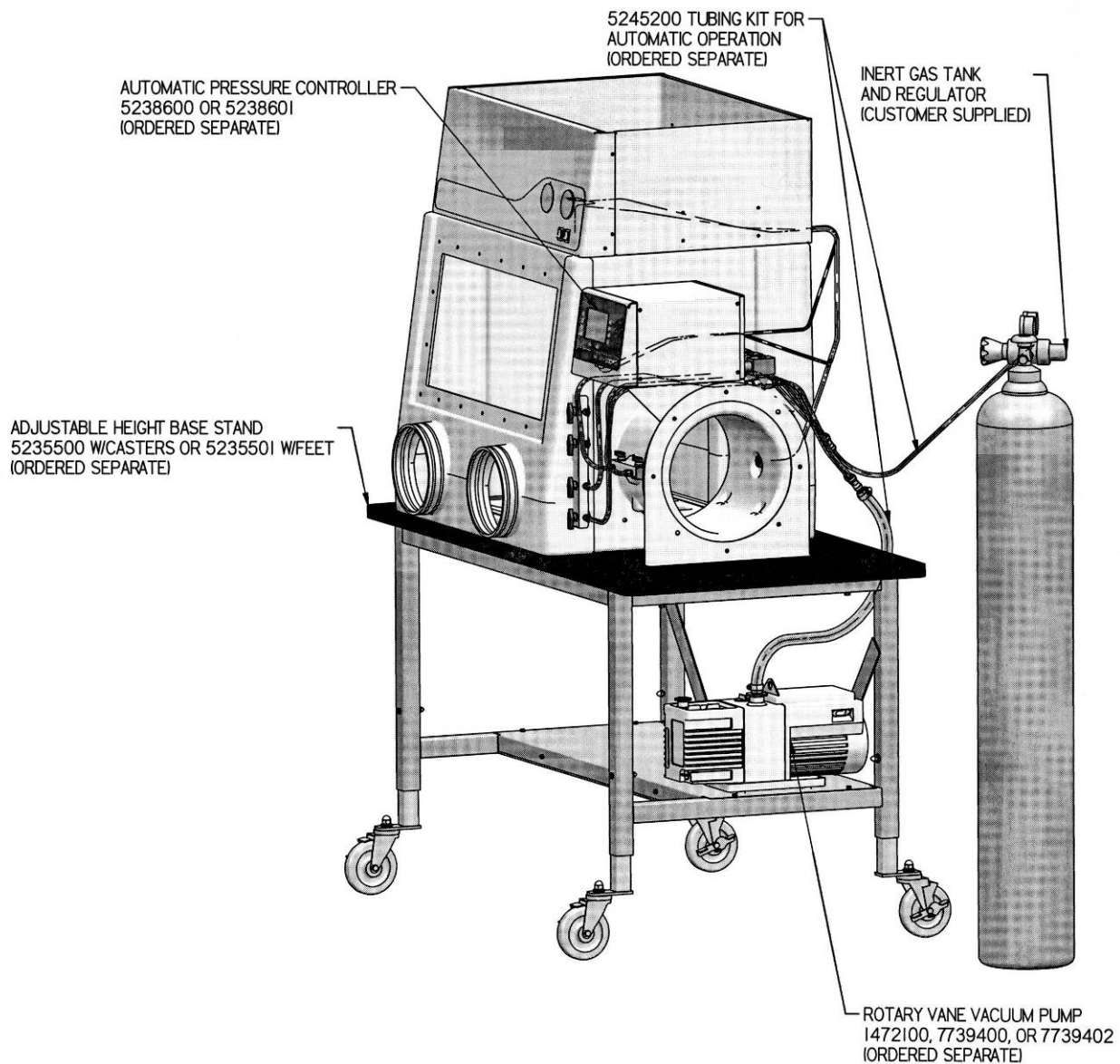

14. Filtration Components for Moisture, Oxygen and Fume Removal

The following components can be used to remove organics, acids, ammonia, oxygen, moisture and other gases as indicated. They are connected to the two auxiliary valves on the main glove box chamber for recirculation of main chamber atmosphere and contaminant removal of air (see Figures 3-9 and 3-10).

Part #	Descriptions
5248200	Vacuum Pump for Circulation, 115V, 60 Hz w/switch
5248201	Vacuum Pump for Circulation, 230V, 50 Hz International
7815301	Canister with Stand for Traps
7815200	Moisture & Solvent Trap Insert; to provide less than 50 ppm moisture (molecular sieve)
7814800	Acid Vapor Trap Insert
7815000	Radioisotope Trap Insert
7995600	Ammonia Trap Insert
5244100	Flowmeter, Visual
5244200	Oxygen and Moisture Removal Column; to provide less than 5 ppm oxygen and less than 50 ppm moisture (refillable)
5244300	Oxygen and Moisture Removal Column Support Stand

15. Drying Train Tubing Kit

Includes the (FEP) tubing and connections required for connecting typical drying train components such as moisture, oxygen, and other gases. Fluorinated ethylene-propylene (FEP) tubing has very low moisture absorption.

Part #	Descriptions
5242500	Drying Train Tubing Kit; moisture, solvents and radioisotopes
5242501	Drying Train Tubing Kit; oxygen and moisture only

See Figures 3-9 and 3-10

16. Gas and Vacuum 0.2 Micron Filter (Part #5240100)

Used for removal of particulates in a drying train, vacuum pump exhaust or inert gas line. 0.25"-0.38" ID tube connection with additional fittings for attachment to 0.50" ID hose.

17. Oxygen Monitors

Oxygen monitors allow the user to continuously monitor oxygen levels inside the glove box. All monitors are placed inside the main chamber. **Never operate a transfer chamber vacuum purge on these sensitive oxygen monitors as damage can occur.**

Part #	Descriptions
5244500	0-10,000 ppm Oxygen Monitor (with three ranges of 0-100 ppm, 100-1,000 ppm, and 1,000-10,000 ppm) 100V/115V – 50/60 Hz
5244501	0-10,000 ppm Oxygen Monitor (with three ranges of 0-100 ppm, 100-1,000 ppm, and 1,000-10,000 ppm) 230V – 50/60 Hz – International
5244400	0.1-100% Oxygen Monitor (1,000 ppm lowest) 100V/115V/230V – 50/60 Hz

18. Moisture Monitors/Hygrometers

Moisture monitors or hygrometers allow the user to continuously monitor moisture levels inside the glove box. All moisture monitors are placed inside the main chamber. **Never operate a transfer chamber vacuum purge on these sensitive hygrometers as damage can occur.**

Part #	Descriptions
5244900	1-1000 ppm Moisture Monitor/Hygrometer (Factory Set at 1-1,000 ppm, with three settings of 1-10 ppm, 1-100 ppm, and 1-1,000 ppm) 100V/115V – 50/60 Hz
5244901	1-1000 ppm Moisture Monitor/Hygrometer (Factory Set at 1-1,000 ppm, with three settings of 1-10 ppm, 1-100 ppm, and 1-1,000 ppm) 230V – 50/60 Hz – International
5244800	0-100% Hand Held Digital Hygrometer with Temperature Display; measures relative humidity and temperature

19. External Glove Port Caps (Part #5242200)

Cap and clamp attaches to the glove ports to eliminate glove inflation during purging and filling operations and reduce the cycle time of the purging/filling process. Sold as a set of two.

20. Acrylic Viewing Window with Frame (Part #5236100)

Acrylic window, 1/2" thick, for those users that prefer acrylic over the standard laminated safety glass (includes metal frame).

21. Guardian Jr.™ Airflow Monitor (Part #5242000)

Audio and visual airflow monitor is especially useful for installations that exhaust the pressure relief valve to the outside. Provides feedback on the roof-mounted blower status. Monitor mounts to the top of the control panel.

22. Interior Storage Shelf Kits

Provide convenient storage in the rear or the left side of the glove box to maximize space. Additional hanging shelf kits (sold separately) can hang from the rear interior shelf kit. **Each shelf kit adds 240 square inches of usable space or an additional 25% of usable space.** Will support a large 15.2" x 4.8" x 3.7" tissue box.

Part #	Descriptions
5235000	Rear Storage Shelf Kit (w/four stainless shelves)
5235001	Side Storage Shelf Kit (w/four stainless shelves)

23. Hanging Shelf Kits

All shelves require the 5235000 rear interior storage shelf kit to function.

Part #	Descriptions
3925000	Consists of three utility shelves
3927700	Bottle Holder
3927800	Tissue Holder (small tissue box)
5247300	Bin Organizer, 5.4" (plastic)
5247301	Bin Organizer, 7.4" (plastic)

24. IV Bar Kit (Part #5242100)

Provides a bar for hanging IV bags or tools. Must be used with one of the interior storage shelf kits (5235000 or 5235001).

25. Gloves (see *Appendix A: Replacement Part numbers for other glove sizes and material types*)

Neoprene gloves are the most resistant to abrasion and tearing. Butyl gloves provide higher impermeability and improved dexterity. Hypalon gloves are made with a mixture of neoprene and butyl rubber to provide an intermediate level of neoprene and butyl features.

26. Pressure Gauge for the Glove Box Main Chamber (Part #5237800)

Kit for the glove box main chamber is already installed on Precise Controlled Atmosphere Glove Boxes. It can be added to the Precise Basic Glove Boxes. Range -5" w.g. to +5" w.g. Kit includes the pressure gauge, hose, and fittings for installation. Installing the pressure gauge requires drilling a 0.562" (14.3mm) diameter hole in the glove box ceiling.

27. Vacuum Gauge for the Transfer Chamber (Part #5237900)

Kit for the transfer chamber is already installed on Precise Controlled Atmosphere Glove Boxes. It can be added to the Precise Basic Glove Boxes. Range 0 to 29 inches of mercury vacuum. Kit includes the vacuum gauge, hose, and fittings for installation. Installing the vacuum gauge requires drilling a 0.562" (14.3mm) diameter hole in the transfer chamber.

28. Transfer Chamber High Vacuum Sleeve (Part #5236200)

This sleeve is included on all Precise Controlled Atmosphere Glove Boxes. **An internal steel reinforced transfer chamber sleeve is required if a vacuum will be pulled in the transfer chamber of the Precise Basic Glove Box.**

29. Exterior Transfer Chamber Shelf (Part #5245900)

A powder-coated steel shelf, 10.7" wide x 15.1" deep, can be attached to the top of the transfer chamber. The exterior transfer chamber shelf maximizes work area, useful for printers, laboratory supplies, and notebooks.

Chapter 8: Electrical System Troubleshooting

Refer to the following table if your glove box fails to operate properly. If the suggested corrective actions do not solve your problem, contact Labconco for additional assistance. The Precise Controlled Atmosphere Glove Box and Precise Basic Glove Box have only two electrical circuits.

PROBLEM	CAUSE	CORRECTIVE ACTION
Lights won't operate.	Unit not plugged into outlet.	Plug unit into appropriate electrical service.
	Circuit breaker(s) tripped.	Reset or replace circuit breaker.
	Lamp not installed properly.	Inspect lamp installation.
	Lamp wiring disconnected.	Inspect lamp wiring.
	Defective lamp.	Replace lamp.
	Light switch is defective.	Replace light switch.
	Defective electronic ballast.	Replace ballast.
	No power to duplex electrical.	Unit not plugged in.
	Circuit breaker(s) tripped.	Reset or replace circuit breaker.
	Duplex switch is defective.	Replace duplex switch.

Appendix A: Replacement Parts

The components that are available for your glove box are listed. The parts shown are the most commonly requested. If other parts are required, please contact Product Service.

Item	Qty.	Part Number	Description
1A	1ea	5232200	Framed Glass Window (standard)
1B	1ea	5236100	Framed Acrylic Window (optional)
2A	1ea	1230700	Receptacle, 115V Duplex
2B	1ea	1283900	Receptacle, 230V Duplex
2C	1ea	5232900	Sealed Duplex, 115V Complete
2D	1ea	5232901	Sealed Duplex, 230V Complete
2E	1ea	5233400	Wallplate Duplex Gray
3A	1pr	1640600	9 ¾ size Neoprene Gloves (standard)
3B	1pr	1640601	9 ¾ size Butyl Gloves
3C	1pr	1640602	9 ¾ size Hypalon Gloves
3D	1pr	1640500	8 ½ size Neoprene Gloves
3E	1pr	1640501	8 ½ size Butyl Gloves
3F	1pr	1640502	8 ½ size Hypalon Gloves
3G	2ea	1640000	O-Rings
3H	2ea	1965600	Clamp – O-Ring Gloves
4	1ea	5236200	Transfer Chamber Inner Support Sleeve
5	1ea	1307000	Switch, Rocker (2 Position)
6A	1ea	5225701	Valve Kit (included on CA)
6B	1ea	1409900	Tube Support Insert
6C	1ea	1408300	Large Ferrule
6D	1ea	1408400	Small Ferrule
6E	1ea	1413602	Stainless Compression Nut
6F	1ea	1413500	Hose Connector (Secondary Method)
6G	order by the foot	1539500	Polyvinyl Chloride Tubing 3/8" OD x 3/16" ID
6H	order by the foot (25' coils)	7396209	FEP Tubing, Drying Train, 3/8" OD x 1/4" ID
6I	1ea	1409901	Tubing Insert, Drying Train, 3/8" OD x 1/4" ID
7	1ea	1365200	Main Glove Box Pressure Gauge (included on CA)
8	1ea	1365300	Transfer Chamber Vacuum Gauge (included on CA)
9A	1ea	5222700	Fluorescent Bulb, 8" Circleline FC8T9/CW, 22 Watt, 4 Pin
9B	1ea	5222800	Ballast, 115V 60 Hz
9C	1ea	5222801	Ballast, 230V 50 Hz (also used on 100V, 50 Hz)
9D	1ea	5222802	Ballast, 230V 60 Hz (also used on 100V, 60 Hz)
9E	1ea	5242900	Transformer, 230V to 100V (100V models only)
10A	1ea	1305800	Inlet Power Cord, 115V
10B	1ea	1305900	Inlet Power Cord, 230V
11A	1ea	5226400	Inner Transfer Door w/attached gasket (Complete Assy.)
11B	1ea	5226500	Outer Transfer Door w/attached gasket (Complete Assy.)
11C	1ea	5226401	Inner Door w/attached gasket only
11D	1ea	5226501	Outer Door w/attached gasket only
12A	1ea	1327204	Circuit Breaker, 5A, 115V
12B	4ea	1327205	Circuit Breaker, 2A, 230V
12C	1ea	1327200	Circuit Breaker, 3A, 115V
13A	REF.	5226900	Wiring Diagram, 115V
13B	REF.	5226901	Wiring Diagram, 230V
14	1ea	5230600	Pressure Relief Valve (included on CA)

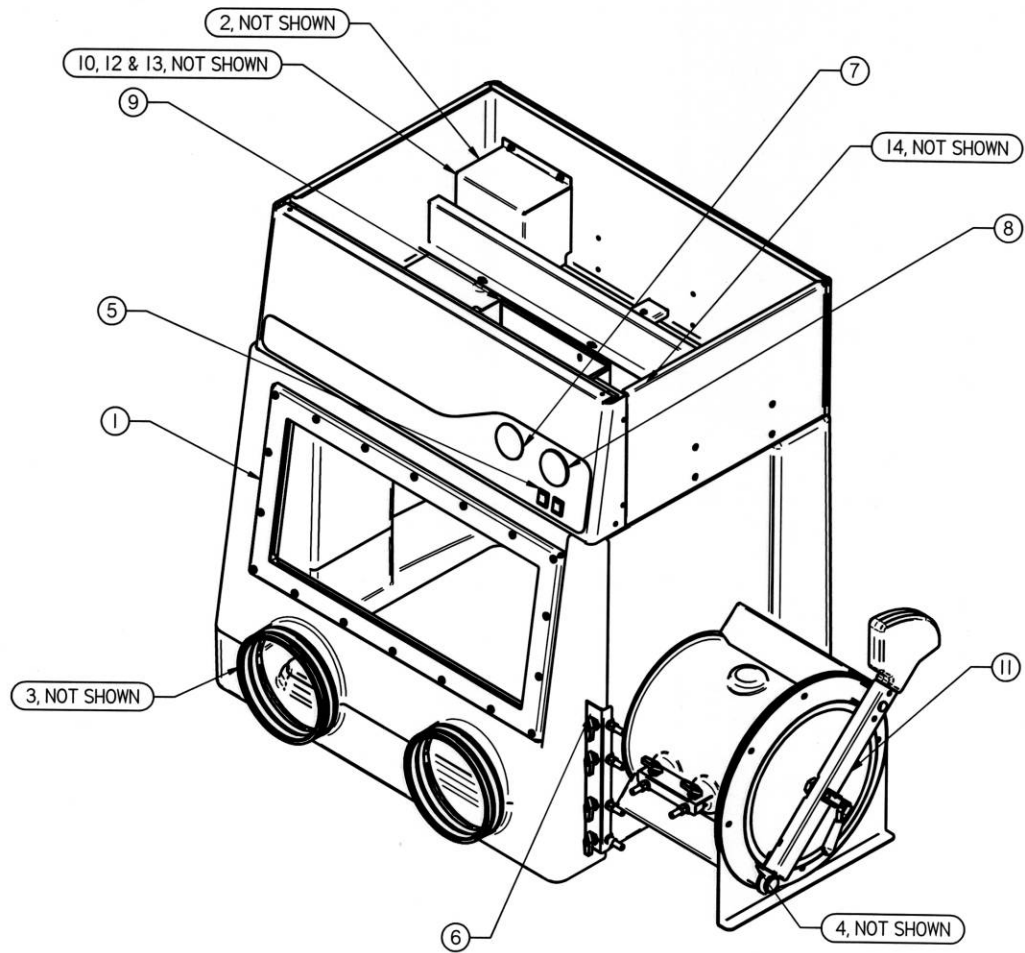

Figure A-1
Replacement Parts for Precise Glove Boxes
(Precise Controlled Atmosphere Glove Box Shown)

Appendix B: Dimensions

See the following dimensions for all the glove boxes. Precise Controlled Atmosphere shown. All dimensions in inches.

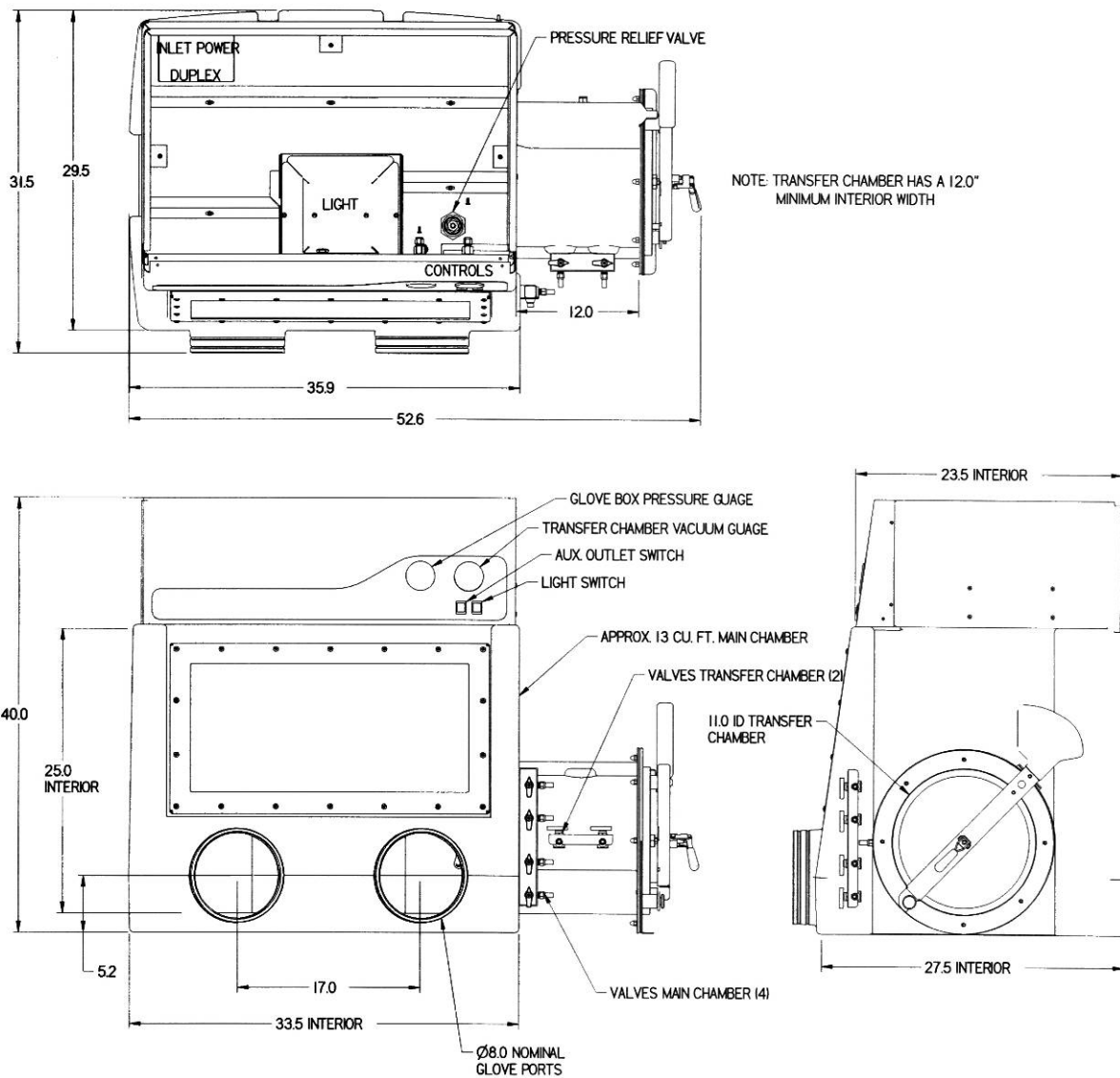

Figure B-1

Note: Six valves, pressure relief valve, and two pressure gauges are omitted on the Precise Basic Glove Box.

Appendix C: Specifications

This Appendix contains technical information about all the glove boxes including electrical specifications and environmental operating conditions.

- 8 Amps, 115V or 4 Amps, 230V, 50/60 Hz or 8 Amps, 100V, 50/60 Hz, Precise Glove Box.

Environmental Conditions

- Indoor use only.
- Maximum altitude: 6562 feet (2000 meters).
- Ambient temperature range: 41° to 120°F (5° to 49°C).
- Maximum relative humidity: 80% for temperatures up to 88°F (31°C), decreasing linearly to 50% relative humidity at 104°F (40°C).
- Main supply voltage fluctuations not to exceed $\pm 10\%$ of the nominal voltage.
- Transient over-voltages according to Installation Categories II (Over-voltage Categories per IEC 1010). Temporary voltage spikes on the AC input line that may be as high as 1500V for 115V models and 2500V for 230V models are allowed.
- Used in an environment of Pollution degrees 2 (i.e., where normally only non-conductive atmospheres are present). Occasionally, however, a temporary conductivity caused by condensation must be expected, in accordance with IEC 664.

Appendix D: Precise Controlled Atmosphere Purge & Fill Reduction Rates

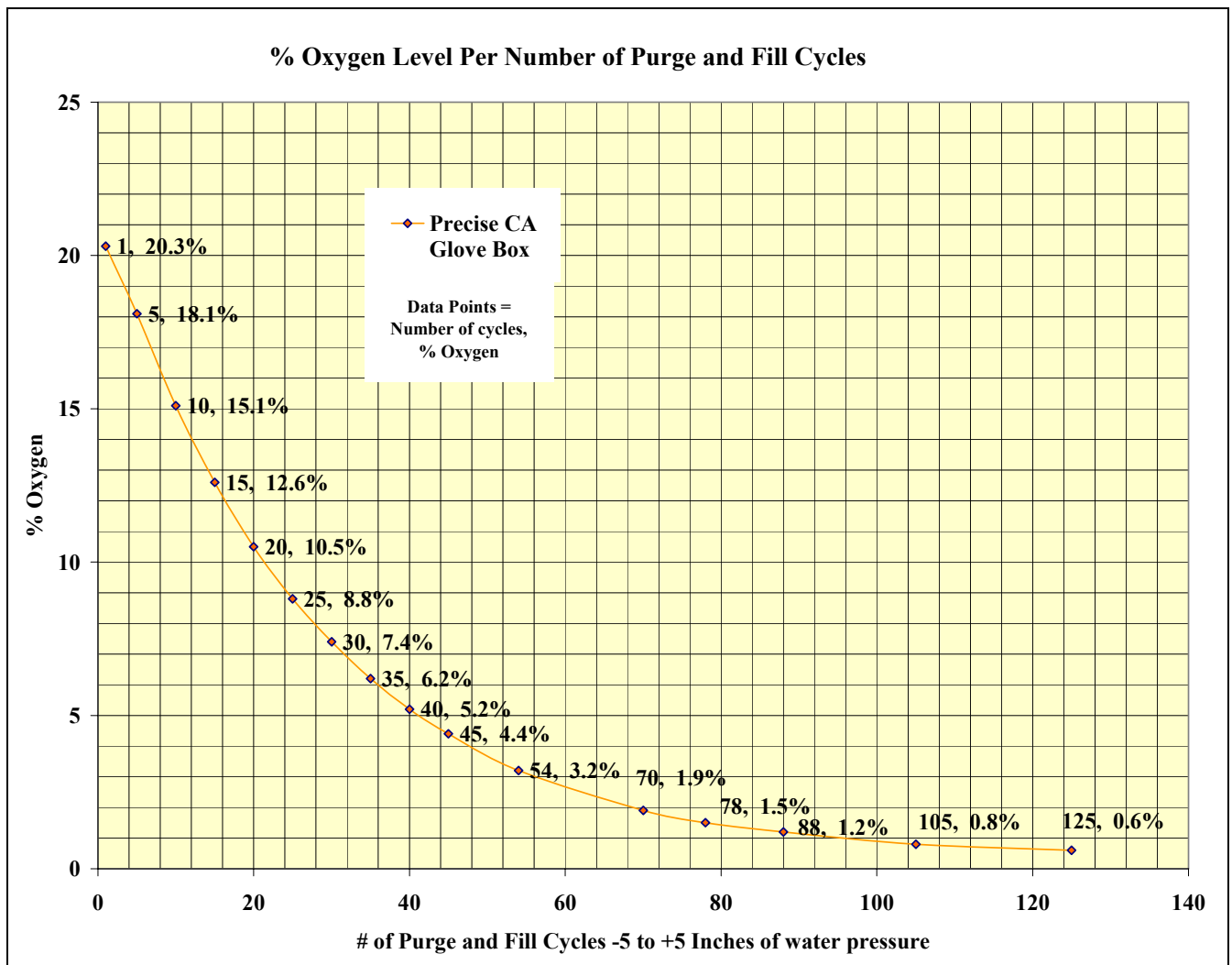

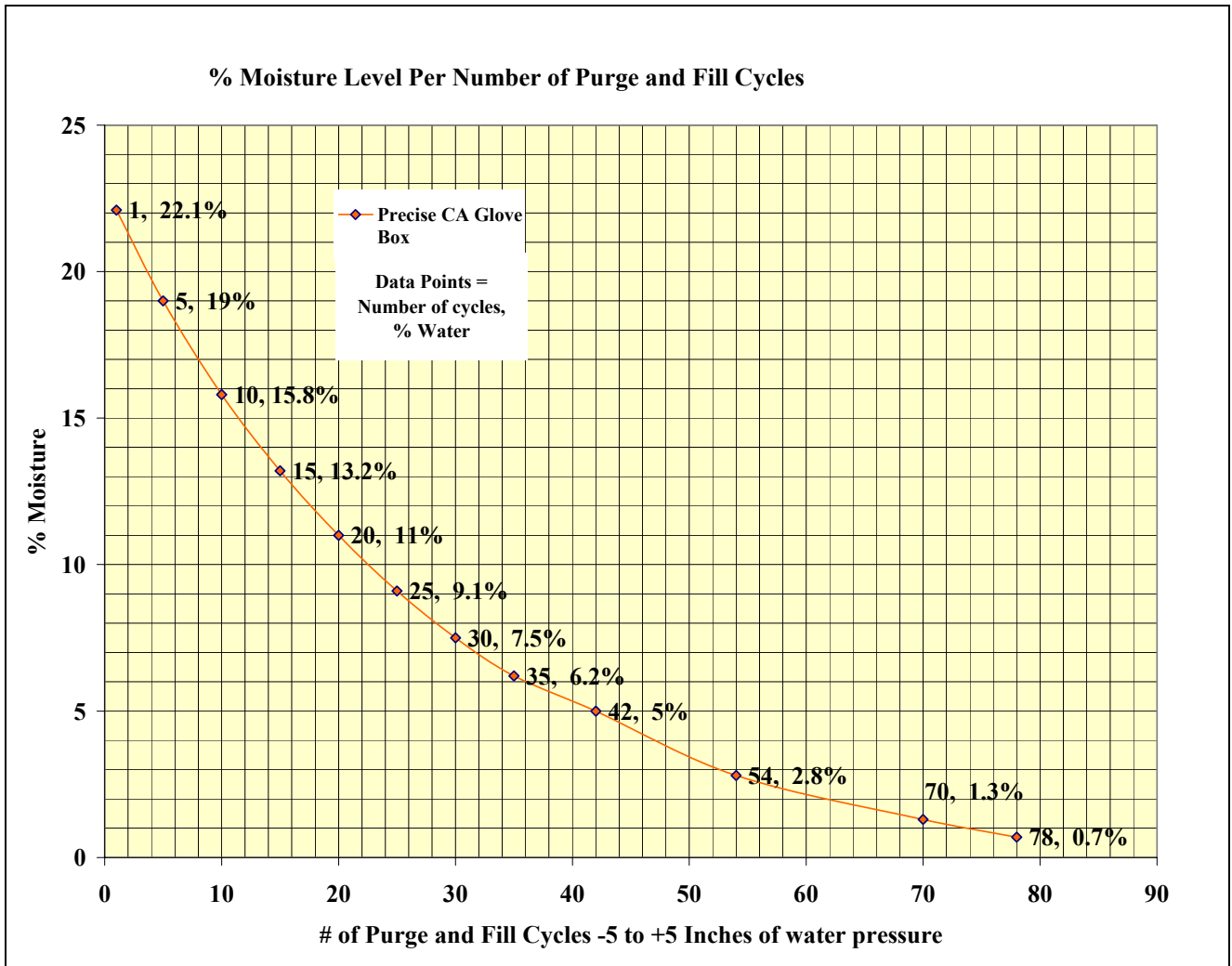

Appendix E: Life Span for Oxygen Removal Column & Moisture Trap Removal

Note: Precise Glove Box Volume is 13 cu. ft. or 368 liters; 3000ppm or 0.3% of 368 liters = 1.1 liters of oxygen initially used

Glove Box Main Chamber Pressure <i>(inches of water)</i>	Oxygen Leak Rate <i>(ppm/min)</i>	Initial Oxygen Capacity Used <i>(ppm)</i>	Catalog# 5244200 Oxygen Column Life <i>(24 hour days)</i>	Total Oxygen Life Capacity <i>(ppm)</i>	Total Oxygen Volume Capacity <i>(liters)</i>	Number of Columns
-1	0.52	3000	21	19022	7	1
0	0.22	3000	51	19022	7	1
1	0.15	3000	74	19022	7	1

Note: All data with glove port covers installed

Glove Box Main Chamber Pressure <i>(inches of water)</i>	Moisture Leak Rate <i>(ppm/min)</i>	Initial Moisture <i>(ppm)</i>	Catalog# 5244200 Moisture Column Life <i>(24 hour days)</i>	Total Moisture Life Capacity <i>(ppm)</i>	Total Moisture Weight Capacity <i>(grams of moisture)</i>	Number of Columns
-1	2.9	10000	3318	13864241	100	1
0	1.7	10000	5659	13864241	100	1
1	1.6	10000	6013	13864241	100	1

Note: 1ppm of moisture = 7.21ug of moisture inside the 368 liter glove box volume

Note: All data with glove port covers installed

Glove Box Main Chamber Pressure <i>(inches of water)</i>	Moisture Leak Rate <i>(ppm/min)</i>	Initial Moisture <i>(ppm)</i>	Catalog# 7815200 Moisture Trap Life <i>(24 hour days)</i>	Total Moisture Life Capacity <i>(ppm)</i>	Total Moisture Weight Capacity <i>(grams of moisture)</i>	Number of Traps
-1	2.9	10000	4314	18023514	130	1
0	1.7	10000	7358	18023514	130	1
1	1.6	10000	7818	18023514	130	1
-1	2.9	10000	8630	36047028	260	2
0	1.7	10000	14721	36047028	260	2
1	1.6	10000	15641	36047028	260	2

Note: 1ppm of moisture = 7.21ug of moisture inside the 368 liter glove box volume

Note: All data with glove port covers installed

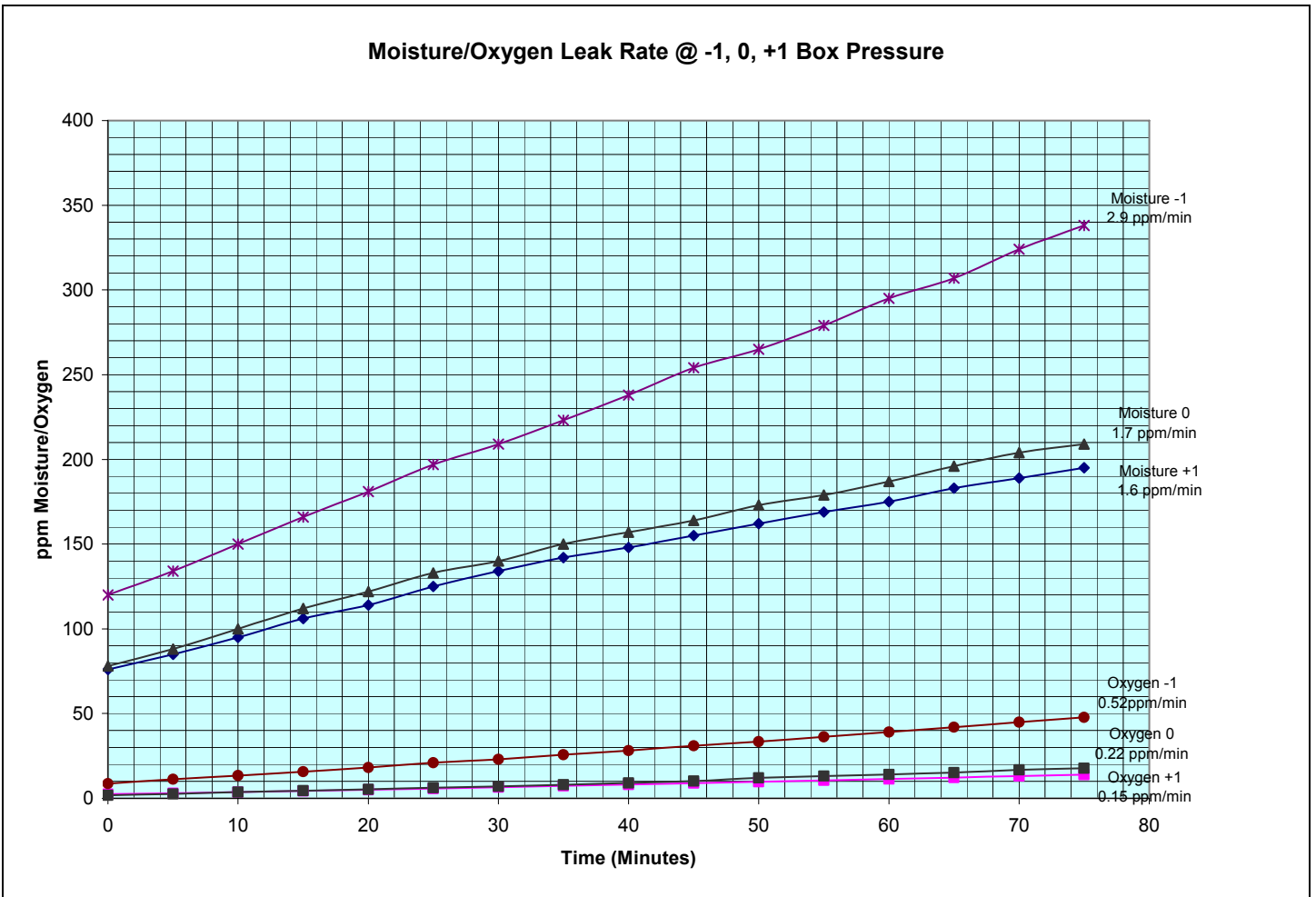

Appendix F: Ionizer Fan Performance Criteria

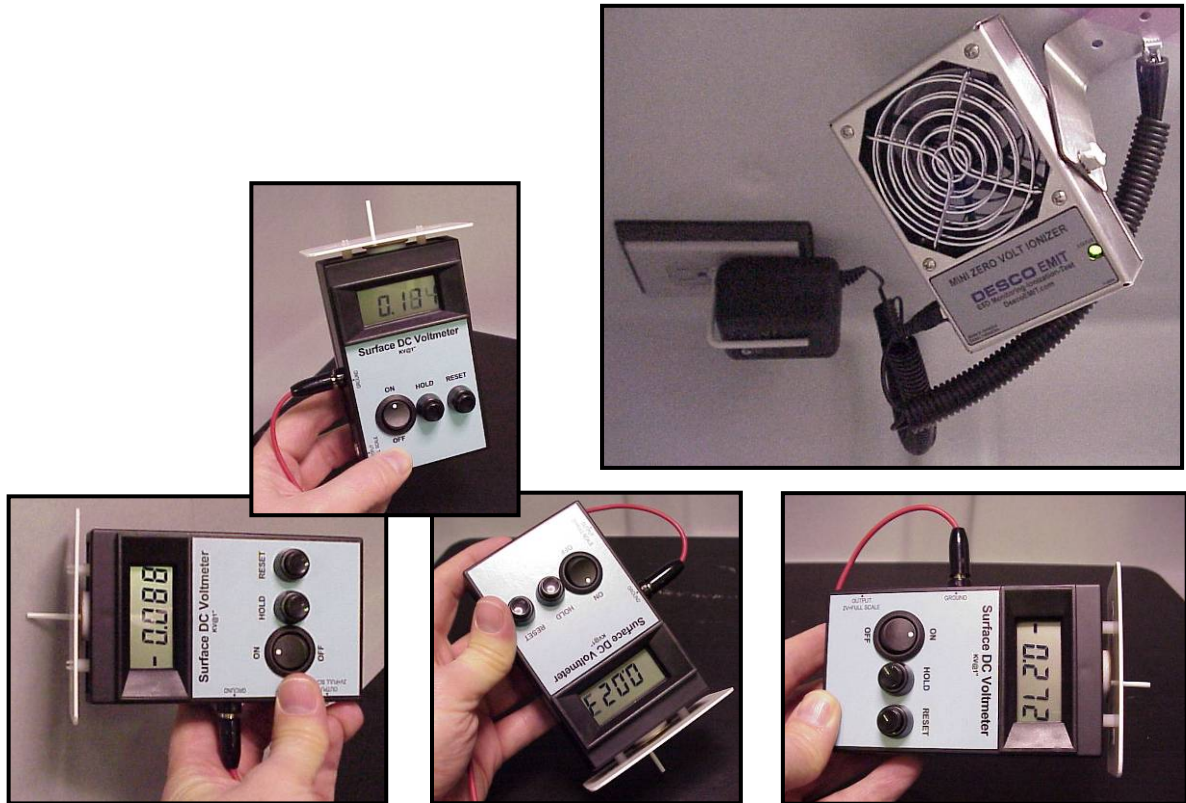

Static Electricity Test

The tests were performed by monitoring the level of static electricity found on the work surface and interior surfaces within the glove box. Static electricity levels were measured with an AlphaLab Surface DC Voltmeter http://scientificmeter.com/surface_dc.htm. A DESCO Emit Mini Zero Volt Ionizer <http://www.descoemit.com/ViewProduct.aspx?pid=50661&h=1323> was installed in the glove box. The DESCO ionizer is a dual steady state DC auto balancing bench top ionizer. The ionizer helps to neutralize static electricity on surrounding surfaces. The time required by the ionizer to neutralize static electricity will be the shortest when objects are within 12" to 36" directly in front of the ionizer. The time for neutralization increases as the distance from the ionizer increases. The time required for sufficient electrostatic decay will also vary depending upon user application, moisture levels within the supply air and the level of cleanliness within the glove box interior.

	Test Point Locations and Voltage Levels							
	Metal Housing Inlet HEPA	Metal Housing Exhaust HEPA	Metal Transfer Chamber Handle	Back Interior Surface	Left Interior Surface	Right Interior Surface	Interior Lamp Window	Center Work Surface
Electrostatic with Glove Box Blower & Ionizer Fan OFF	+ 420	+ 220	+ 734	+ 375	+ 106	+ 151	+ 242	+ 153
100 CFM Blower & Ionizer Fan ON After 1 Hour	+ 96	+ 114	+ 290	+ 93	+ 45	+ 52	+ 46	+ 35
100 CFM Blower & Ionizer Fan ON After 2 Hours	+ 28	+ 58	+ 51	- 52	- 15	- 20	- 28	- 22

Static Electricity Test Results (VOLTS) on the Glove Box (Neutralization is best between +/-100V)

The mini zero volt ionizer’s neutralization time will be shortest when objects are approximately 12" to 36" directly in front of the ionizer and will increase as the distance from the ionizer increases. Set the fan speed switch on the side of the ionizer to the LOW or HIGH position. Higher airflow will result in faster neutralization rates. Position the ionizer so that the maximum airflow is directed at the items or area to be neutralized. The LED will turn on during power up and remain GREEN during normal operation. The ionizer has a grounding jack and must have a good earth ground to maintain proper balance. Always plug the AC power adaptor into the ionizer and then into the appropriate AC power source. The ionizer has no On/Off switch so it should be running as soon as it is plugged in. The ionizer is designed to run off of 24VDC ±10% 300mA.

The balance adjustment for the ionizer can be accomplished by inserting a small screwdriver or trimmer adjustment tool into the balance adjustment hole located on the side of the unit. To increase the output in a positive direction, turn the potentiometer in a clockwise direction. Conversely, to increase the output in a negative direction, turn the potentiometer in a counter clockwise direction. It is recommended that you use a surface DC voltmeter when adjusting the balance of the ionizer.

Under normal conditions, the ionizer will attract dirt and dust (especially on the emitter electrodes). To maintain optimum neutralization efficiency and operation, cleaning with isopropyl alcohol should be performed on a regular basis. If the performance of the ionizer degrades because of dirty or corroded points, the LED on the front of the unit will turn YELLOW; the audible alarm will sound continuously. Under this condition, the unit is not able to maintain balanced ionization. The input power cord must be disconnected before the unit is opened for maintenance. The emitter electrodes should be cleaned using the alcohol cleaners included or a swab wet with isopropyl alcohol. Unscrew the 4 screws on the back of the unit and then remove the screen. After cleaning the emitter electrodes, reinstall the screen and 4 screws. The emitter electrodes should not require replacement during the life of the unit with normal handling. Verify the balance of the ionizer with a surface DC voltmeter after cleaning.

Appendix G:

Helium Leak Test Procedure

Purpose

The purpose of this test is to assure that all gasketed joints and seams of the enclosure are helium leak tight.

Test Setup

1. Connect one of the valves to a vacuum pump.
2. Connect the other valve to a helium supply tank regulated between 10 and 15 PSI.
3. Install two neoprene gloves onto the glove ports using standard O-rings and clamps.
4. For testing the Precise Basic Glove Box, a test fixture attaches to one of the glove ports and replaces one of the gloves.

Test Procedure

1. Be sure the inner transfer chamber door is latched closed and the outer door is open.
2. Open the helium inlet test valve and allow box to pressurize to +5 H₂O gauge then close valve. Then with the vacuum pump running, open the test outlet valve and allow the box to be evacuated to -5" H₂O gauge then close valve. Repeat this purge/fill for a total of three cycles then close both valves.
3. While Glove Box pressure is held at +5.0" minimum, sniff all Glove Box joints, seals and seams of the Glove Box shell using a test probe connected to a helium mass spectrometer (Inficon model or equal calibrated at 1.7×10^{-7} STD. CC/SEC). Also sniff the inner transfer door seal by inserting test probe through the outer transfer chamber door. Any detectable leaks greater than 1×10^{-4} STD.CC/SEC is cause for rejection. Pressure relief valve is measured 1/2" away.
4. Close and latch the outer door and open the inner door. Adjust Glove Box pressure to +5.0".
5. Sniff the outer transfer door seal and make sure there are no leaks greater than rate specified in Step 3 above.

Pressure Relief Valve Test Procedure

1. See that pressure relief valve opens when pressures and vacuum exceed +/- 6" to 10" w.g. Record data. Check that valve reseals within 2" w.g. of opening pressure and opening vacuum. Pressure relief valve is standard on Precise Controlled Atmosphere Glove Boxes.

Other Equipment

1. For a less critical helium leak measurement using a lower cost leak detector, Labconco recommends using Restek (www.restek.com) or other instrumentation available from a laboratory supply dealer.

Appendix H: Plumbing Diagrams

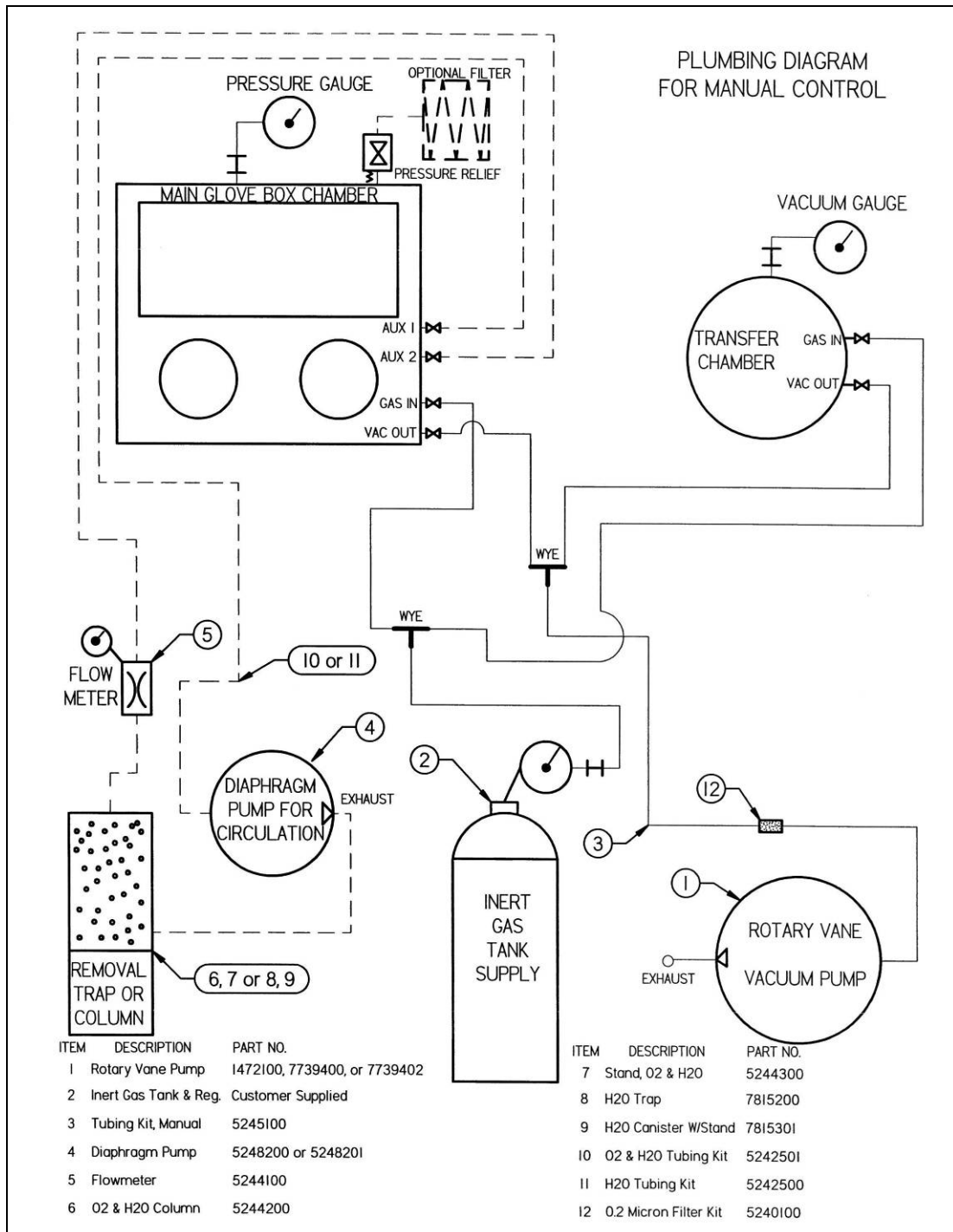

Appendix H: Plumbing Diagrams

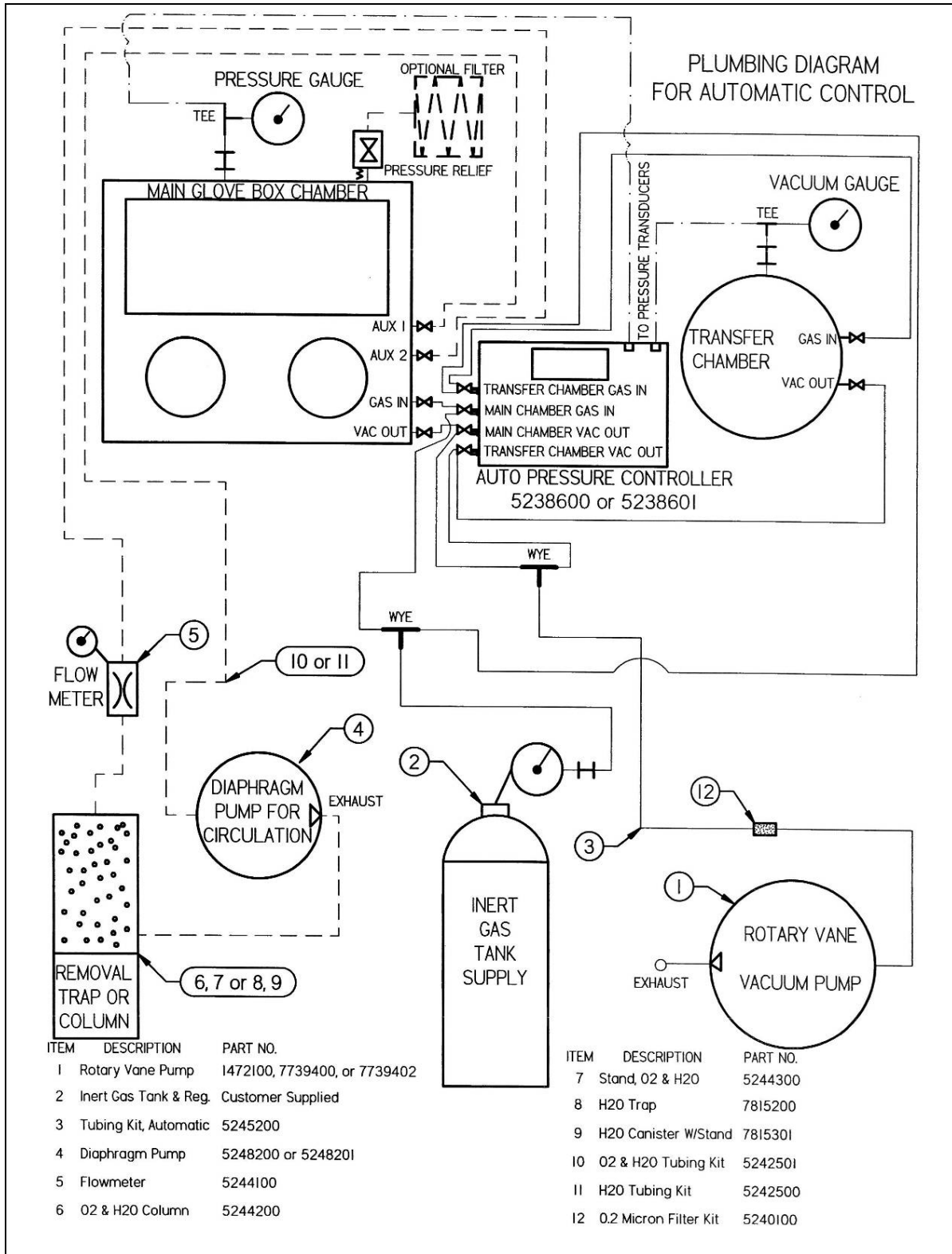

Appendix I: Conversions

Pressure Conversions

To From	mmHg	in.Hg	in.H ₂ O	ft.H ₂ O	atm	lb/in. ²	Kg/cm ²	kPa	bar
mmHg	1	.03937	.5353	.04461	.00132	.01934	.00136	.1333	.0013
in.Hg	25.40	1	13.60	1.133	.03342	.4912	.03453	3.387	.0339
in.H ₂ O	1.868	.07355	1	.08333	.00246	.03612	.00254	.2490	.0025
ft.H ₂ O	22.42	.8826	12	1	.02950	.4334	.03048	2.988	.0299
atm	760	29.92	406.8	33.90	1	14.70	1.033	101.3	1.013
lb/in. ²	51.71	2.036	27.69	2.307	.06805	1	.07031	6.895	.0689
Kg/cm ²	735.6	28.96	393.7	32.81	.9678	14.22	1	98.05	.981
kPa	7.500	.2953	4.016	.3347	.00987	.1451	.0102	1	.01
bar	750	29.53	401.6	33.47	.987	14.51	1.02	100	1

Flow Rate Conversions

To From	lit/sec	gal/min	ft ³ /sec	ft ³ /min	bbl/hr	bbl/day
lit/sec	1	15.85	0.03532	2.119	22.66	543.8
gal/min	0.06309	1	0.00223	0.1337	1.429	34.30
ft ³ /sec	28.32	448.8	1	60	641.1	1.54x10 ⁴
ft ³ /min	0.4719	7.481	0.01667	1	10.69	256.5
bbl/hr	0.04415	0.6997	0.00156	0.09359	1	24
bbl/day	0.00184	0.02917	6.50x10 ⁻⁵	0.00390	0.04167	1

Appendix J: References

Many excellent reference texts and booklets are currently available. The following is a brief listing:

Pharmaceutical Isolators, A Guide to their application design and control.
Pharmaceutical Press 2004, Editors: Midcalf, Phillips, Neiger, and Coles.

Isolation Technology, A Practical Guide, 2004 CRC Press, 2nd Edition,
www.crcpress.com

International Standard ISO 10648-2 Containment Enclosures

- Classification according to leak tightness and associated checking methods.

NIOSH Pocket Guide to Chemical Hazards
U.S. Dept of Health and Human Resources
Centers for Disease Control and Prevention
National Institute for Occupational Safety and Health

DECLARATION OF CONFORMITY

Application Council Directive(s): 73/23/EEC, 89/336/EEC, 2002/95/EC (ROHS),
2002/96/EC (WEEE)

Standard(s) to which conformity is declared: EN61010-1, EN61326-1

Manufacturer's Name: Labconco Corporation

Manufacturer's Address: 8811 Prospect Avenue
Kansas City, MO 64132 USA

Importer's Name: See Shipping/Customs Documents

Importer's Address: See Shipping/Customs Documents for your equipment

Type of Equipment: Laboratory Equipment Precise Glove Boxes

5220000 Series Precise Basic Glove Box
5220100 Series Precise Controlled Atmosphere Glove Box
5220200 Series Precise HEPA-Filtered Glove Box
5220300 Series XPert Weigh Box

Serial No.: Various – See Individual Declaration

Year of Manufacture: 2006 and subsequent

I, the undersigned, hereby declare that the equipment specified above conforms to the
above Directive(s) and Standard(s).

See individual Declaration of Conformity which
will be signed by the importer for your country.

Place: _____
(Signature)

Date: _____
(Full Name)

(Position)